

Si photodiode S1227 series

For UV to visible, precision photometry; suppressed IR sensitivity

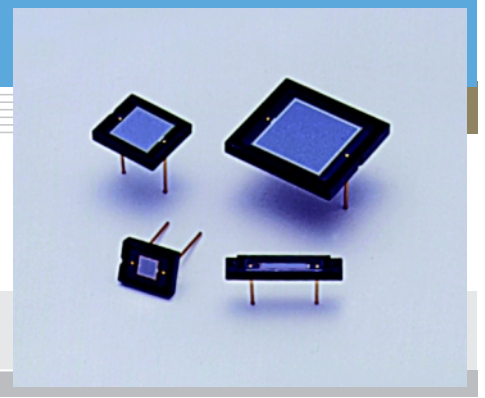

Features

- High UV sensitivity: QE 75 % ($\lambda=200$ nm)
- Suppressed IR sensitivity
- Low dark current

Applications

- Analytical equipment
- Optical measurement equipment, etc.

General ratings / Absolute maximum ratings

Type No.	Dimensional outline/ Window material *	Package (mm)	Active area size (mm)	Effective active area (mm ²)	Absolute maximum ratings		
					Reverse voltage V _R Max. (V)	Operating temperature T _{opr} (°C)	Storage temperature T _{stg} (°C)
S1227-16BQ	①/Q	2.7 × 15	1.1 × 5.9	5.9	5	-20 to +60	-20 to +80
S1227-16BR	②/R						
S1227-33BQ	③/Q	6 × 7.6	2.4 × 2.4	5.7			
S1227-33BR	④/R						
S1227-66BQ	⑤/Q	8.9 × 10.1	5.8 × 5.8	33			
S1227-66BR	⑥/R						
S1227-1010BQ	⑦/Q	15 × 16.5	10 × 10	100			
S1227-1010BR	⑧/R						

Electrical and optical characteristics (Typ. T_a=25 °C, unless otherwise noted)

Type No.	Spectral response range λ (nm)	Peak sensitivity wavelength λ_p (nm)	Photo sensitivity S (A/W)				Short circuit current I _{sc} 100 lx		Dark current I _D V _R =10 mV Max. (pA)	Temp. coefficient T _{CID} (times/°C)	Rise time t _r V _R =0 V R _L =1 k Ω (μ s)	Terminal capacitance C _t V _R =0 V f=10 kHz (pF)	Shunt resistance R _{sh} V _R =10 mV (G Ω)		NEP (W/Hz ^{1/2})
			λ_p	200 nm		He-Ne Laser 633 nm	Min. (μ A)	Typ. (μ A)					Min.	Typ.	
				Min.	Typ.										
S1227-16BQ	190 to 1000	720	0.36	0.10	0.12	0.34	2	3.2	1.12	0.5	170	2	20	2.5 × 10 ⁻¹⁵	
S1227-16BR	320 to 1000		0.43	-	-	0.39	2.2	3.7				2	20	2.1 × 10 ⁻¹⁵	
S1227-33BQ	190 to 1000		0.36	0.10	0.12	0.34	2	3.0		0.5	160	2	20	2.5 × 10 ⁻¹⁵	
S1227-33BR	320 to 1000		0.43	-	-	0.39	2.2	3.7				2	20	2.1 × 10 ⁻¹⁵	
S1227-66BQ	190 to 1000		0.36	0.10	0.12	0.34	11	16		20	2	950	0.5	5	5.0 × 10 ⁻¹⁵
S1227-66BR	320 to 1000		0.43	-	-	0.39	13	19					0.5	5	4.2 × 10 ⁻¹⁵
S1227-1010BQ	190 to 1000		0.36	0.10	0.12	0.34	32	44		50	7	3000	0.2	2	8.0 × 10 ⁻¹⁵
S1227-1010BR	320 to 1000		0.43	-	-	0.39	36	53					0.2	2	6.7 × 10 ⁻¹⁵

* Window material Q: quartz glass, R: resin coating

■ Spectral response

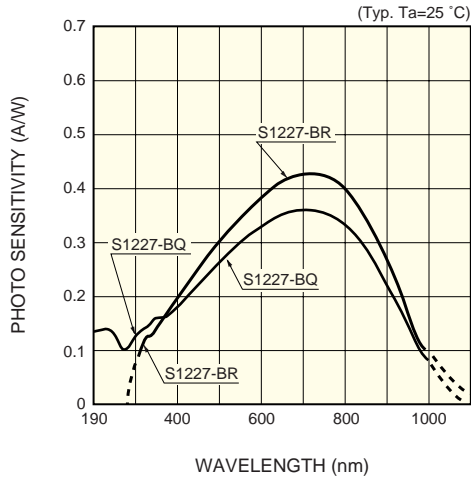

■ Photo sensitivity temperature characteristic

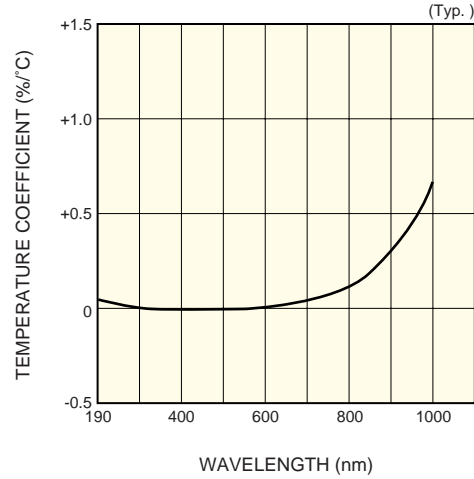

■ Rise time vs. load resistance

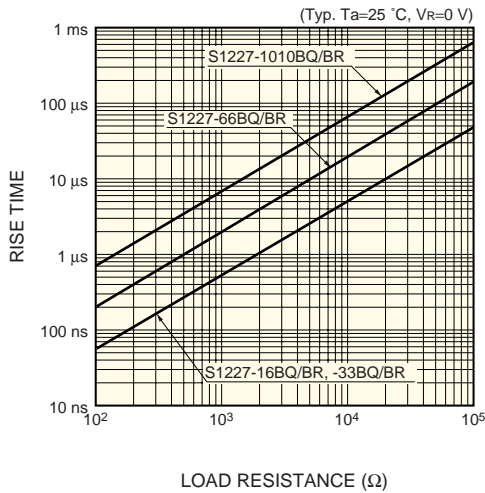

■ Dark current vs. reverse voltage

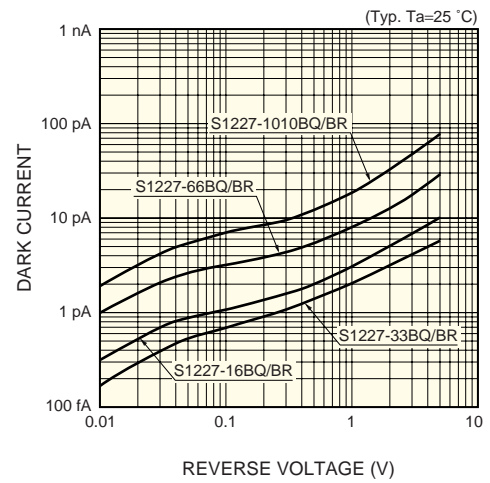

■ Shunt resistance vs. ambient temperature

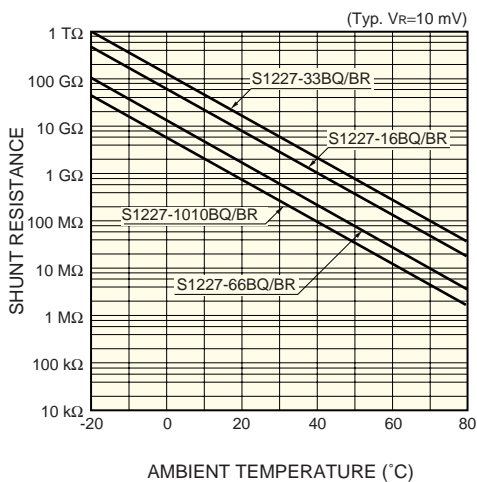

■ Dimensional outlines (unit: mm)

① S1227-16BQ

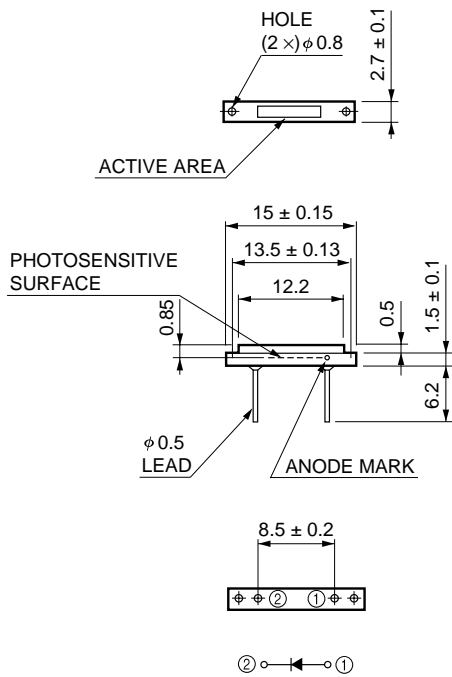

KSPDA0094EA

② S1227-16BR

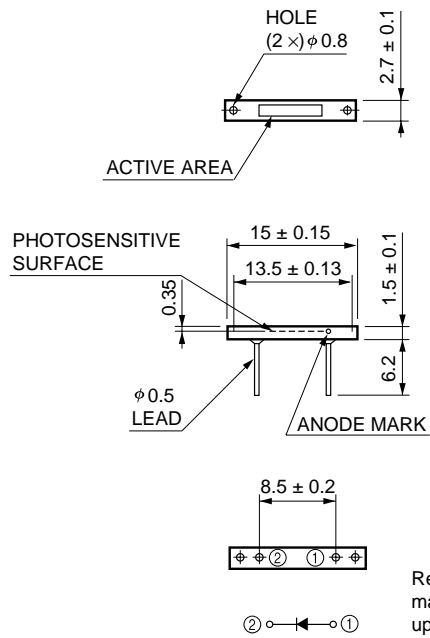

KSPDA0095EA

Resin coating may extend a maximum of 0.1 mm above the upper surface of the package.

③ S1227-33BQ

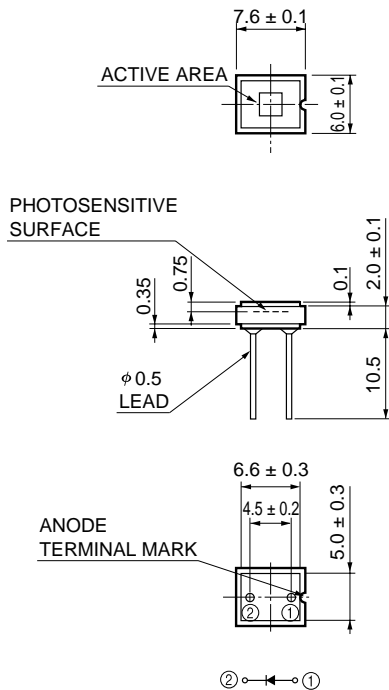

KSPDA0096EA

④ S1227-33BR

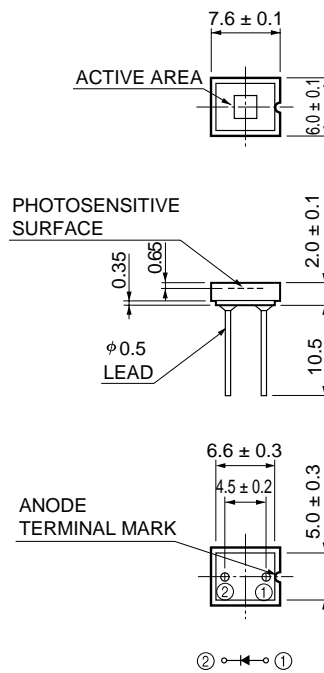

KSPDA0097EA

Resin coating may extend a maximum of 0.1 mm above the upper surface of the package.

⑤ S1227-66BQ

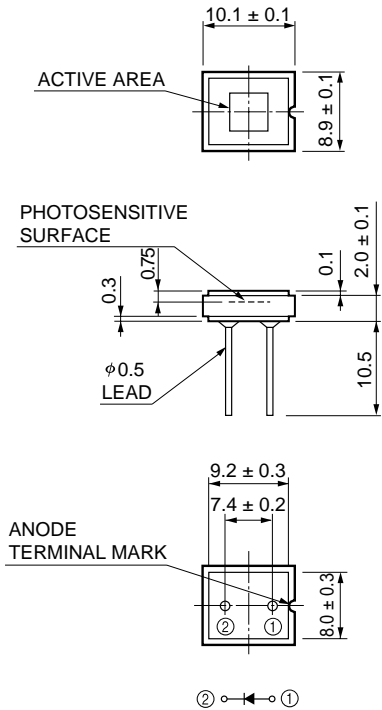

KSPDA0098EA

⑥ S1227-66BR

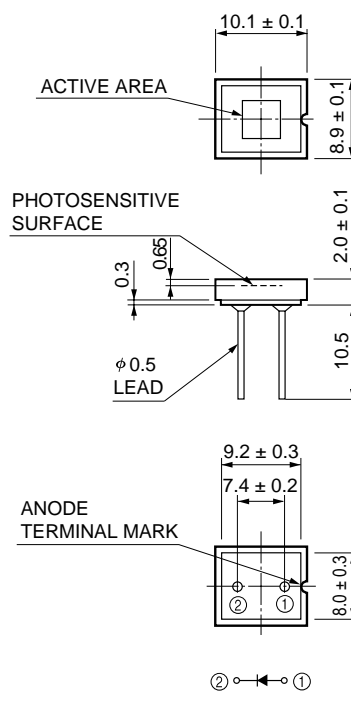

KSPDA0099EA

Resin coating may extend a maximum of 0.1 mm above the upper surface of the package.

⑦ S1227-1010BQ

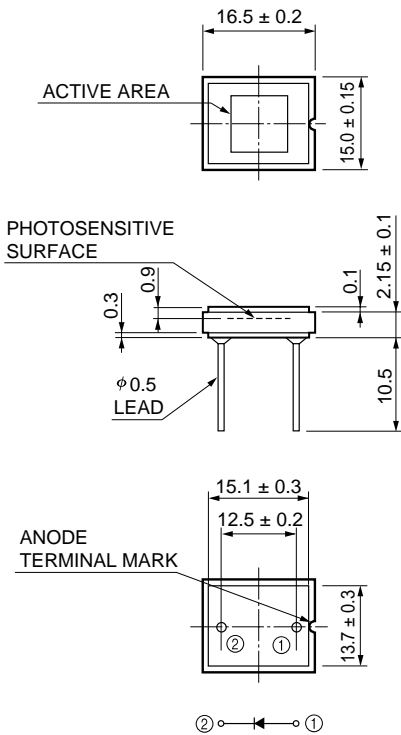

KSPDA0100EA

⑧ S1227-1010BR

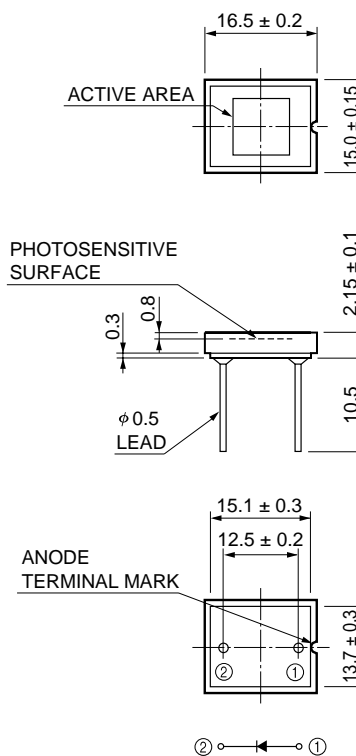

KSPDA0101EA

Resin coating may extend a maximum of 0.1 mm above the upper surface of the package.

HAMAMATSU

Information furnished by HAMAMATSU is believed to be reliable. However, no responsibility is assumed for possible inaccuracies or omissions. Specifications are subject to change without notice. No patent rights are granted to any of the circuits described herein. ©2004 Hamamatsu Photonics K.K.

HAMAMATSU PHOTONICS K.K., Solid State Division

1126-1 Ichino-cho, Higashi-ku, Hamamatsu City, 435-8558 Japan, Telephone: (81) 53-434-3311, Fax: (81) 53-434-5184, <http://www.hamamatsu.com>

U.S.A.: Hamamatsu Corporation: 360 Foothill Road, P.O.Box 6910, Bridgewater, N.J. 08807-0910, U.S.A., Telephone: (1) 908-231-0960, Fax: (1) 908-231-1218

Germany: Hamamatsu Photonics Deutschland GmbH: Arzbergerstr. 10, D-82211 Herrsching am Ammersee, Germany, Telephone: (49) 08152-3750, Fax: (49) 08152-2658

France: Hamamatsu Photonics France S.A.R.L.: 19, Rue du Saule Trépu, Parc du Moulin de Massy, 91882 Massy Cedex, France, Telephone: 33-(1) 69 53 71 00, Fax: 33-(1) 69 53 71 10

United Kingdom: Hamamatsu Photonics UK Limited: 2 Howard Court, 10 Tewin Road, Welwyn Garden City, Hertfordshire AL7 1BW, United Kingdom, Telephone: (44) 1707-294888, Fax: (44) 1707-325777

North Europe: Hamamatsu Photonics Norden AB: Smidesvägen 12, SE-171 41 Solna, Sweden, Telephone: (46) 8-509-031-00, Fax: (46) 8-509-031-01

Italy: Hamamatsu Photonics Italia S.R.L.: Strada della Moia, 1/E, 20020 Arese, (Milano), Italy, Telephone: (39) 02-935-81-733, Fax: (39) 02-935-81-741