

# AN3275SB

## CM detection IC for VCRs in the North American market

### ■ Overview

The AN3275SB is an IC which detects both a low luminance of video signal and a low sound amplitude based on ~~COMMERCIAL~~-ADVANCE that is ADLE Inc.'s patent of the CM detection technology. Using this IC and a free memory area in a microcomputer, you can easily carry out a CM detection for VCRs used in the North America.

### ■ Features

- Video black detection
- Low sound detection
- Generation of various masking pulses  
(Detecting H-mask, V-mask and envelope)
- Generation of the pulse (CLR pulse) for an event latch
- Usable for COMMERCIAL ADVANCE, MOVIE ADVANCE and CA-LITE

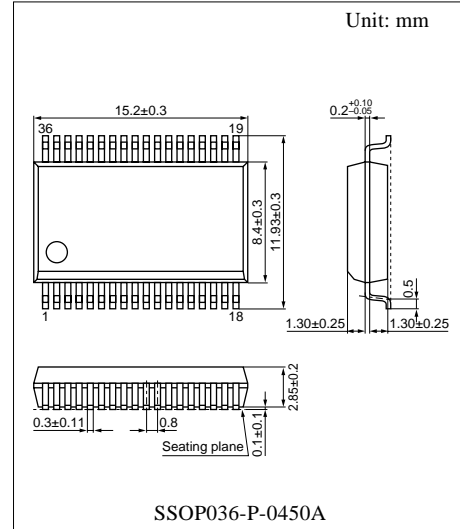

### ■ Applications

- Stand-alone VCR

### ■ Block Diagram

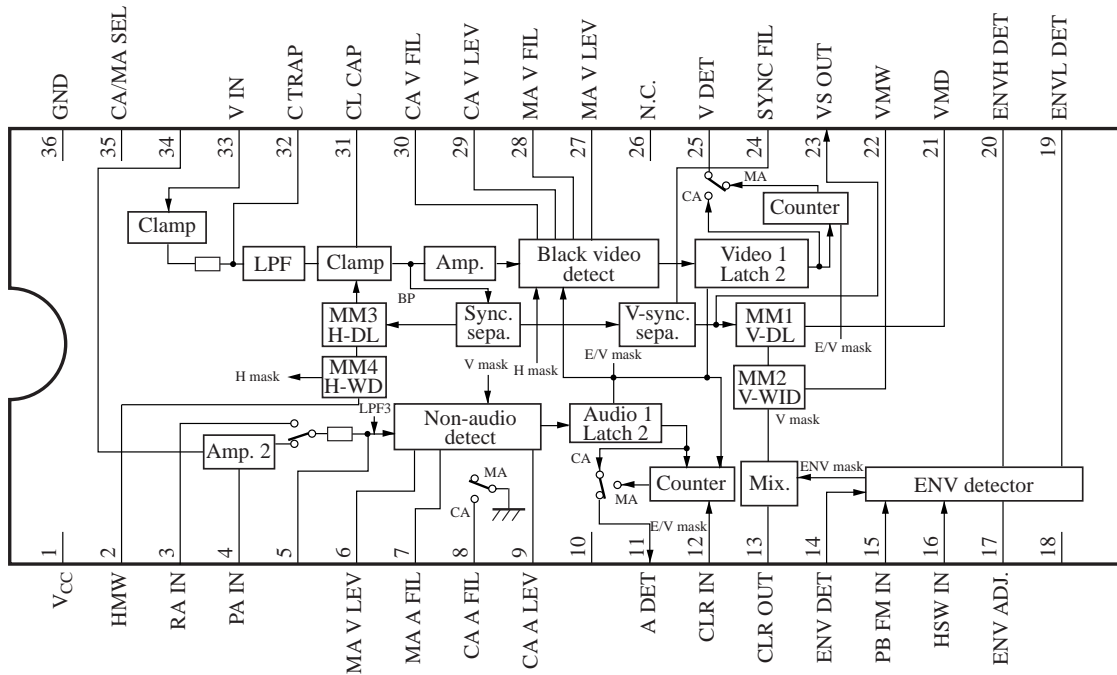

Note) ~~COMMERCIAL~~-ADVANCE is a trademark registered by SRT, Inc., invented by Jerry Iggulden who closed a licensing contract under the cooperation of Arthur D. Little Enterprises, Inc.

### ■ Pin Descriptions

Pin No.	Symbol	Description	Pin No.	Symbol	Description
1	V <sub>CC</sub>	Supply voltage (5 V typ.)	19	ENV L DET	PB FM envelope peak detection (below)
2	HMW	H-mask width period adjustment			
3	RA IN	Audio recording input	20	ENV H DET	PB FM envelope peak detection (upper)
4	PA IN	Audio playback input			
5	A FIL	Audio filter	21	VMD	V-mask time delay adjustment
6	MA A LEV	MOVIE ADVANCE audio detection level adjustment	22	VMW	V-mask width period adjustment
7	MA A FIL	MOVIE ADVANCE audio filter	23	VS OUT	Vertical sync. signal output
8	CA A FIL	COMMERCIAL ADVANCE audio filter	24	SYNC FIL	Vertical sync. signal separation filter
9	CA A LEV	COMMERCIAL ADVANCE audio detection level adjustment	25	V DET	Black picture detection output to a microcomputer
10	A DC	Audio DC	26	N.C	No connection
11	A DET	Audio detection latch output to a microcomputer	27	MA V LEV	MA video detection level adjustment
12	CLR IN	E/V mask pulse input	28	MA V FIL	MA video filter control
13	CLR OUT	E/V mask pulse output	29	CA V LEV	CA video detection level adjustment
14	ENV DET	PB FM envelope detection filter	30	CA V FIL	CA video filter control
15	PB FM IN	PB FM envelope input	31	CL CAP	Capacitor for clamping
16	HEAD AMP SW	Head amp. switch pulse input	32	C TRAP	Chroma trap filter
17	ENV ADJ.	ENV mask level adjustment	33	VIN	Video input
18	V DET OUT	Video detection delay adjustment	34	A REF	Audio reference
			35	CA/MA SEL	Selection of CA, MA (CA-LITE)
			y 36	GND	Signal processing circuit GND

### ■ Absolute Maximum Ratings

Parameter	Symbol	Rating	Unit
Supply voltage	V <sub>CC</sub>	5.5	V
Supply current	I <sub>CC</sub>	35	mA
Power dissipation *2	P <sub>D</sub>	450	mW
Operating ambient temperature *1	T <sub>opr</sub>	-20 to +70	°C
Storage temperature *1	T <sub>stg</sub>	-55 to +125	°C

Note) \*1: Except for the power dissipation, operating ambient temperature, and storage temperature, all ratings are for T<sub>a</sub> = 25°C.

\*2: The power dissipation shown is for the IC package at T<sub>a</sub> = 70°C.

### ■ Recommended Operating Range

Parameter	Symbol	Range	Unit
Supply voltage	$V_{CC}$	4.75 to 5.25	V

### ■ Electrical Characteristics at $V_{CC} = 5.0\text{ V}$ , $T_a = 25^\circ\text{C}$

Parameter	Symbol	Conditions	Min	Typ	Max	Unit
Supply current	$I_{CC}$	MA mode	—	21	28	mA
CA mode hold voltage	$V_{35H}$	—	3.5	—	5.0	V
CL SLP mode hold voltage	$V_{35M}$	—	1.75	—	3.0	V
CL SP,MA mode hold voltage	$V_{35L}$	—	0	—	1.25	V
Pin 32 output impedance	$R_{32}$	—	1 830	2 030	2 230	$\Omega$
Pin 5 output impedance	$R_5$	—	4 505	5 005	5 505	$\Omega$
VSS pulse high level	$V_{23H}$	Output 23, with 10 k $\Omega$ to GND	4.0	—	—	V
VSS pulse low level	$V_{23L}$	Output 23, with 10 k $\Omega$ to $V_{CC}$	—	—	0.5	V
CLR pulse high level	$V_{13H}$	Output 13, with 10 k $\Omega$ to GND	4.0	—	—	V
CLR pulse low level	$V_{13L}$	Output 13, with 10 k $\Omega$ to $V_{CC}$	—	—	0.5	V
Video det. output high level	$V_{25H}$	Output 25, with 10 k $\Omega$ to GND	4.0	—	—	V
Video det. output low level	$V_{25L}$	Output 25, with 10 k $\Omega$ to $V_{CC}$	—	—	0.5	V
Audio det. output high level	$V_{11H}$	Output 11, with 10 k $\Omega$ to GND	4.0	—	—	V
Audio det. output low level	$V_{11L}$	Output 11, with 10 k $\Omega$ to $V_{CC}$	—	—	0.5	V
Black det. level 1 (CA mode) *1	$V_{DET1}$	Input 33, output 25 Video signal: 140IRE = 2.1 V[p-p]	10.5	13	15.5	(IRE)
Black det. level 2 (CA mode) *1	$V_{DET1}$	Input 33, output 25 Video signal: 140IRE = 2.1 V[p-p]	8.5	11	13.5	(IRE)
Non-audio detection level 1 (CA mode)	$A_{DET1}$	Input 3, output 11 Pin 7: 47 k $\Omega$ to GND, $f_{IN} = 1.0\text{ kHz}$	56	76	96	mV[p-p]
Non-audio detection level 2 (MA mode)	$A_{DET2}$	Input 4, output 11 Pin 7: 47 k $\Omega$ to GND, $f_{IN} = 5\text{ kHz}$	1.8	3.6	5.4	mV[p-p]
Black detection adjustment range 1 *1	$V_{AD1}$	Input 33, output 25, pin 29 = DC, sweep: 140 IRE = 2.1 V[p-p]	7	—	28	(IRE)
Black detection adjustment range 2 *1	$V_{AD2}$	Input 33, output 25, pin 27 = DC, sweep: 140 IRE = 2.1 V[p-p]	7	—	28	(IRE)
Non-audio detection adjustment range 1	$A_{AD1}$	Input 3, output 11 Pin 9 = DC, sweep, $f_{IN} = 1.0\text{ kHz}$	50	—	100	mV[p-p]
Non-audio detection adjustment range 2	$A_{AD2}$	Input 4, output 11 Pin 6 = DC, sweep, $f_{IN} = 5\text{ kHz}$	2.4	—	5.2	mV[p-p]
V-mask delay	$t_{VD}$	Input 33, output 13 Delay from VSS: 0.1 $\mu\text{F}$ , pin 21: 0.1 $\mu\text{F}$	1.65	1.95	2.25	ms
V-mask width	$t_{VW}$	Input 33, output 13, pin 22: 0.22 $\mu\text{F}$	11	12.5	14	ms

Note) \*1: The unit which stands for the ratio of the video signal amplitude to a total amplitude. 140IRE = 2.1 V[p-p]

■ Electrical Characteristics at  $V_{CC} = 5.0\text{ V}$ ,  $T_a = 25^\circ\text{C}$  (continued)

Parameter	Symbol	Conditions	Min	Typ	Max	Unit
H-mask delay	$t_{HD}$	Input 33, output 30, delay from HSS	10.5	12.5	14.5	$\mu\text{s}$
H-mask width	$t_{HW}$	Input 33, output 30, pin 2: 2 700 pF	30	34	38	$\mu\text{s}$
ENV detection level	SE	Input 15, output 13, $V_{IN} = 200\text{ mV[p-p]}$	-5.5	-7.5	-9.5	dB

• Design reference data

Note) The characteristics below are theoretical values based on the IC design and are not guaranteed.

Parameter	Symbol	Conditions	Min	Typ	Max	Unit
<b>Black detection block</b>						
Pin33 sync. DC level	$V_{SY33}$	Input 33, output 33 Pin 33: 1.0 $\mu\text{F}$ , 140IRE = 2.1 V[p-p]	—	1.8	—	V
Chroma trap frequency characteristics	$f_{V2}$	Input 33, output 30 Ratio of pin 30 = 500 kHz to 3.58 MHz	—	-35	—	dB
LPF2 frequency characteristics	$f_{V3}$	Input 33, output 30 Ratio of pin 30 = 500 kHz to 1.0 MHz	—	-3.0	—	dB
Pin 30 output dynamic range *1	$V_{30}$	Input 33, output 30 Pin 30: 10 k $\Omega$ to GND	—	30	—	(IRE)
Pin 30 pedestal DC level	$V_{PD30}$	Input 33, output 30 Pin 30: 10 k $\Omega$ to GND	—	1.6	—	V
Pin 28 output dynamic range *1	$V_{28}$	Input 33, output 28 Pin 28: 10 k $\Omega$ to GND	—	30	—	(IRE)
Pin 28 pedestal DC level	$V_{PD28}$	Input 33, output 28 Pin 28: 10 k $\Omega$ to GND	—	1.6	—	V
Masking level DC offset	$\Delta V_{PD}$	Input 33, output 28 Pin 28: 10 k $\Omega$ to GND, pin 2 = GND	-2.0	0.0	0.2	V
Black detection hysteresis	$\Delta V_{VCN}$	Input 28, output 18 Pin 28 = triangular wave	105	130	155	mV[p-p]
<b>HSS,VSS block</b>						
Sync. separation minimum input sensitivity	$S_{HSS}$	Input 33, output 24 Pin 33: $V_{IN} = 2.1\text{ V[p-p]}$ , white 100%	—	40	—	%
HSS front edge delay	$t_{DHSS}$	HSS front edge delay from input 33, output 24, pin 33	—	1.0	—	$\mu\text{s}$
VSS front edge delay	$t_{DVSS}$	Input 33, output 23	—	25	—	$\mu\text{s}$
VSS pulse width	$t_{wVSS}$	Input 33, output 23	—	215	—	$\mu\text{s}$
<b>Non-audio detection block</b>						
LPF3 frequency characteristics	$f_{A1}$	Input 4, output 7 Ratio of pin 7 = 5 kHz to 15 kHz	—	-3	—	dB
Pin 7 output dynamic range	$\Delta V_7$	Input 4, output 7	—	5.0	—	mV[p-p]

Note) \*1: The unit which stands for the ratio of the video signal amplitude to a total amplitude. 140IRE = 2.1 V[p-p]

■ Electrical Characteristics at  $V_{CC} = 5.0\text{ V}$ ,  $T_a = 25^\circ\text{C}$  (continued)

• Design reference data (continued)

Note) The characteristics below are theoretical values based on the IC design and are not guaranteed.

Parameter	Symbol	Conditions	Min	Typ	Max	Unit
Envelope detection block						
ENV detection adjustment range	$E_{AD}$	Input 15, output 13 $V_{IN} = \text{pin 15, } 200\text{ mV[p-p]}$	-3	—	+3	dB
ENV detection hysteresis	$\Delta V_{ENON}$	Input 15, output 13 $V_{IN} = \text{pin 15, } 200\text{ mV[p-p]}$	—	1.7	—	dB
SP ENV pulse front edge delay	$t_{DHSW}$	Input 16, output 13 $V_{IN} = \text{rectangular wave, } 0\text{ V to } 5\text{ V } 300\text{ Hz}$	—	0.4	—	$\mu\text{s}$
SP ENV pulse width	$t_{WSHW}$	Input 16, output 13 $V_{IN} = \text{rectangular wave, } 0\text{ V to } 5\text{ V } 300\text{ Hz}$	—	570	—	$\mu\text{s}$
SP ENV pulse hysteresis	$\Delta V_{HSON}$	Input 16, output 13 $V_{IN} = \text{triangular wave, } 2\text{ V[p-p] } 300\text{ Hz}$	—	80	—	mV[p-p]

■ Terminal Equivalent Circuits

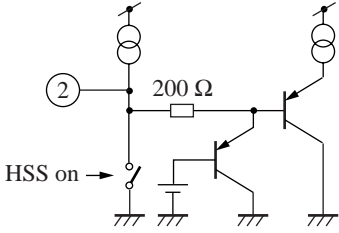
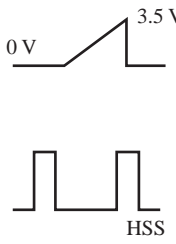
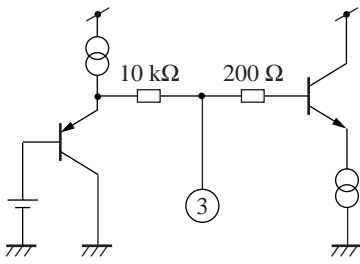
Pin No.	Equivalent circuit	Impedance	Signal waveform	DC (V)
1	$V_{CC}$	—	—	5.0
2	<p>HMW</p> 	Current output		—
3	<p>RA IN (CA)</p> 	10 k $\Omega$	Sin wave	2.3

■ Terminal Equivalent Circuits (continued)

Pin No.	Equivalent circuit	Impedance	Signal waveform	DC (V)
4	<p>PA IN (MA, CL)</p>	10 kΩ	<p>Sin wave</p>	2.3
5	<p>A FIL</p>	5005 Ω		1.5
6	<p>MAALEV</p>	21 kΩ	DC	2.1
7	<p>MAAFIL</p>	Current output		—

■ Terminal Equivalent Circuits (continued)

Pin No.	Equivalent circuit	Impedance	Signal waveform	DC (V)
8	<p>CAAFIL</p>	Tr-C	DC	CA 0 V MA open
9	<p>CAALEV</p>	19 kΩ	DC	2.1
10	<p>A DC</p>	10 kΩ	DC	2.8
11	<p>A DET</p>	Tr-C		—

■ Terminal Equivalent Circuits (continued)





Pin No.	Equivalent circuit	Impedance	Signal waveform	DC (V)
12	<p>CLR IN</p>	Tr-B		0
13	<p>CLR OUT</p>	Tr-C		—
14	<p>ENVDET</p>	2.0 kΩ		1.0
15	<p>PB FM IN</p>	20 kΩ		2.7

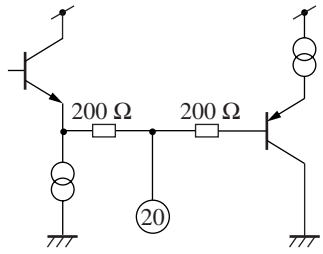

■ Terminal Equivalent Circuits (continued)

Pin No.	Equivalent circuit	Impedance	Signal waveform	DC (V)
16	<p>HEAD AMP SW</p>	11 kΩ		1.3
17	<p>ENV ADJ.</p>	25 kΩ	DC	2.7
18	<p>V DET OUT</p>	Tr-B		0
19	<p>ENV L DET</p>	200 Ω		3.3

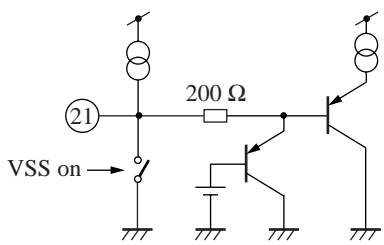
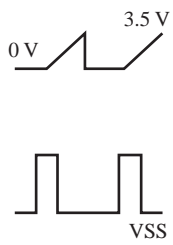
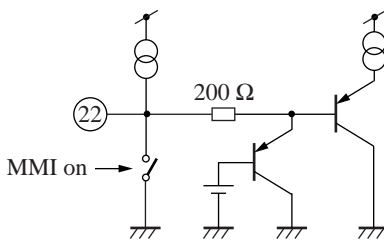
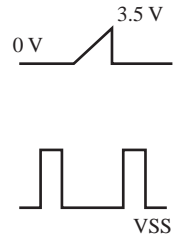
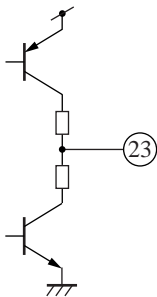
■ Terminal Equivalent Circuits (continued)

Pin No.	Equivalent circuit	Impedance	Signal waveform	DC (V)
20	ENV H DET 	200 Ω		1.8
21	VMD 	Current output		—
22	VMW 	Current output		—
23	VS OUT 	Tr-C		—

■ Terminal Equivalent Circuits (continued)

Pin No.	Equivalent circuit	Impedance	Signal waveform	DC (V)
24	<p>SYNC FIL</p>	2 100 Ω		1.5
25	<p>V DET</p>	Tr-C		—
26	<p>N.C.</p>	—	—	—
27	<p>MA V LEV</p>	25 kΩ	DC	2.6
28	<p>MA V FIL</p>	1 000 Ω	DC	Pedestal 1.8

■ Terminal Equivalent Circuits (continued)

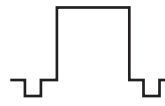
Pin No.	Equivalent circuit	Impedance	Signal waveform	DC (V)
29	<p>CA V LEV</p>	25 kΩ	DC	2.9
30	<p>CA V FIL</p>	200 Ω	DC	Pedestal 1.8
31	<p>CL CAP</p>	Push-pull	DC	3.0
32	<p>CTRAP</p>	2 030 Ω		Sync. 1.8

■ Terminal Equivalent Circuits (continued)

Pin No.	Equivalent circuit	Impedance	Signal waveform	DC (V)
33	<p>V IN</p>	Tr-E		Sync. 1.8
34	<p>A REF (AUDIO reference)</p>	25 kΩ	DC	2.9
35	<p>CA/MA SEL</p>	25 kΩ	DC	2.5
36	GND	—	—	—

**■ Reference****• Description on COMMERCIAL ADVANCE:**

The COMMERCIAL ADVANCE technology is focused on detecting a black level existing between a program and a CM in the TV broadcasting in the North America and the rental video tapes so as to let a microcomputer recognize a CM part by its algorithm in order to skip the CM automatically. This IC is designed for a black level detection of a video signal and for no-sound detection.

There are the following three modes in the CA technology:

**1) COMMERCIAL ADVANCE mode**

Once a program is recorded in this mode, its CM part is automatically identified and is skipped from the next playback.

First it identifies the CM in recording the program, then puts a mark on the CM position on the video tape so that the mark can be detected at the playback to erase the sound of the marked part and display a blue color on the TV screen.

In the case that the tape not recorded in the commercial advance mode has been played back in this particular mode, the marking will be done and the commercial will be skipped from the next playback.

**2) MOVIE ADVANCE mode**

The mode is used to play back the recorded rental video tape. You can automatically skip the commercials or commercial promotions (preview) placed before a movie start and can move to a movie starting point. In this mode, there are two modes available: one that skips all of a preview commercial and the other that stops skipping just before a preview commercial, so that you can make a choice when you want to watch a preview commercial.

**3) CA-LITE mode**

In any programs recorded by either way, the VCR enters into a FORWARD SEARCH mode if a user presses the Skip button, and when a commercial is skipped, the skipping process stops automatically. Since the end of the commercial group is detected by software just after the last CM has passed, the VCR runs a reverse search for a short time then returns to a normal play mode and starts a program again.

■ Application Circuit Example

- System example

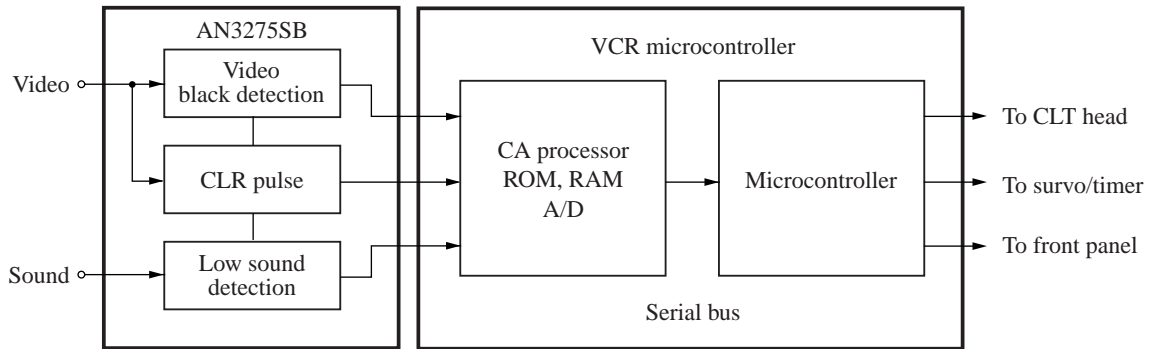

- IC application circuit example

