

DD Dolby* B Type Noise Reduction System with Playback Equalizer Amplifier

Description

The CXA2510AQ is an IC designed for use in car stereo cassette decks. Functions include Dolby B type noise reduction (NR) system, playback equalizer amplifier and music sensor into a single chip.

Features

- Few external parts
- Small package (40-pin QFP)
- Same pin configuration as for the Dolby B-C type NR system (CXA2511AQ) and no Dolby NR system (CXA2509AQ)
- Dolby B type NR and playback equalizer amplifier into a single chip
- FORWARD/REVERSE head select switch
- Two-system (TAPE/AUX) input select switch
- Music signal interval detection level can be set by the external resistors/capacitors (2 modes).
- High-frequency cut-off of the music sensor circuit can be adjusted by the external capacitance.

Applications

- Car stereo cassette decks
- Playback-only cassette decks

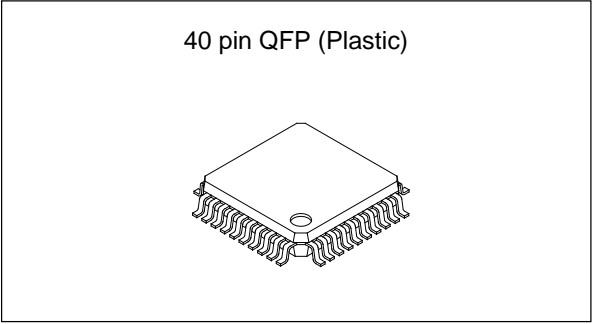

Structure

Bipolar silicon monolithic IC

Absolute Maximum Ratings

| | | | |
|-------------------------|------------------|-------------|----|
| • Supply voltage | V _{CC} | 12 | V |
| • Operating temperature | T _{opr} | -40 to +85 | °C |
| • Storage temperature | T _{stg} | -65 to +150 | °C |
| • Power dissipation | P _D | 430 | mW |

Operating Condition

| | | | |
|----------------|-----------------|-----------|---|
| Supply voltage | V _{CC} | 7.8 to 11 | V |
|----------------|-----------------|-----------|---|

* This IC is available only to the licensees of Dolby Laboratories Licensing Corporation from whom licensing and applications information may be obtained.

* "Dolby" and the double D symbols are trademarks of Dolby Laboratories Licensing Corporation.

Sony reserves the right to change products and specifications without prior notice. This information does not convey any license by any implication or otherwise under any patents or other right. Application circuits shown, if any, are typical examples illustrating the operation of the devices. Sony cannot assume responsibility for any problems arising out of the use of these circuits.

Block Diagram and Pin Configuration

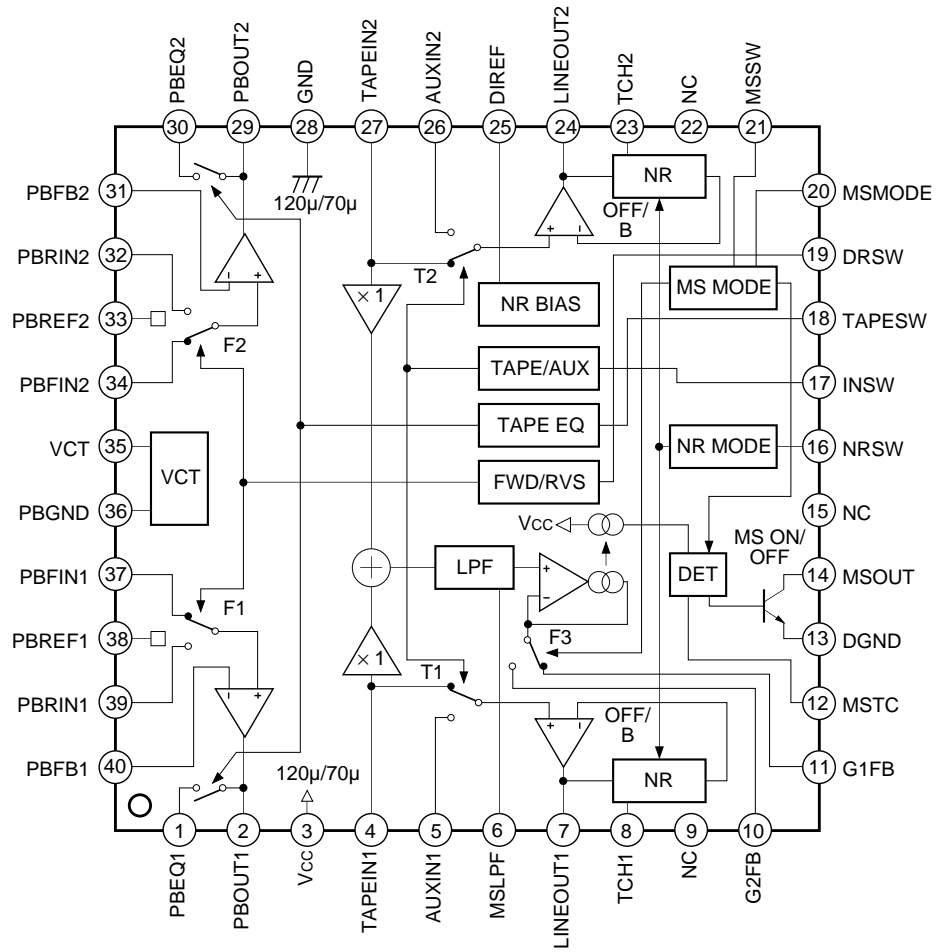

Pin Description

(Ta = 25°C, Vcc = 8.0V, DVcc = 5.0V)

| Pin No. | Symbol | Typical pin voltage | | I/O | I/O resistance | Equivalent circuit | Description |
|---------|--------------------|---------------------|--------|-----|----------------|--------------------|---|
| | | DC | AC | | | | |
| 1 30 | PBEQ1 PBEQ2 | 4.0V | — | O | — | | Resistance for selecting the playback equalizer amplifier time constant |
| 2 29 | PBOUT1 PBOUT2 | 4.0V | -25dBm | O | — | | Playback equalizer amplifier output |
| 3 | Vcc | 8.0V | — | — | — | | Power supply |
| 4 27 | TAPEIN1 TAPEIN2 | 4.0V | -30dBm | I | 40kΩ | | TAPE input |
| 5 26 | AUXIN1 AUXIN2 | | | | | | External input |
| 6 | MSLPF | 4.0V | — | — | 100kΩ | | Cut-off frequency adjustment of the music sensor LPF |

| Pin No. | Symbol | Typical pin voltage | | I/O | I/O resistance | Equivalent circuit | Description |
|----------|----------------------|---------------------|-------|-----|----------------|--------------------|---|
| | | DC | AC | | | | |
| 7 24 | LINEOUT1 LINEOUT2 | 4.0V | -6dBm | O | — | | Line output |
| 8 23 | TCH1 TCH2 | 0.3V | — | — | — | | Time constant for the HLS |
| 10 11 | G2FB G1FB | 4.0V | — | — | — | | Music signal interval detection level setting |
| 12 | MSTC | — | — | — | — | | Time constant for detecting the music signal interval |
| 13 | DGND | 0.0V | — | — | — | | Logic ground (Connect to GND.) |

| Pin No. | Symbol | Typical pin voltage | | I/O | I/O resistance | Equivalent circuit | Description |
|---------|--------|--|----|-----|----------------|--------------------|--|
| | | DC | AC | | | | |
| 14 | MSOUT | 0.2V when a signal is detected; DVcc when no signal is detected | — | O | — | | Time constant for detecting the music signal interval |
| 17 | INSW | 0.0V when open | — | I | 100kΩ | | Line amplifier input select control Low (open): TAPEIN High: AUXIN |
| 21 | MSSW | | | | | | Music sensor control Low (open): MS ON High: MS OFF |
| 16 | NRSW | | | | | | Dolby NR control Low (open): NR OFF High: NR ON |
| 18 | TAPESW | 0.0V when open | — | I | 100kΩ | | Playback equalizer amplifier control Low (open): 120μs High: 70μs |
| 19 | DRSW | | | | | | Head select control Low (open): FORWARD High: REVERSE |
| 20 | MSMODE | 0.0V when open | — | I | 100kΩ | | Music sensor mode control Low (open): G1 High: G2 |

| Pin No. | Symbol | Typical pin voltage | | I/O | I/O resistance | Equivalent circuit | Description |
|----------|------------------|---------------------|--------|-----|----------------|--------------------|---|
| | | DC | AC | | | | |
| 25 | DIREF | 1.2V | — | — | — | | Resistance for setting the Dolby NR reference current (Connects 18kΩ between DIREF pin and GND for the standard setting.) |
| 28 | GND | 0.0V | — | — | — | | Ground |
| 31 40 | PBFB2 PBFB1 | 4.0V | -70dBm | I | — | | Playback equalizer amplifier feedback |
| 32 39 | PBRIN2 PBRIN1 | 4.0V | -70dBm | I | — | | Playback equalizer amplifier input (REVERSE head connected) |
| 34 37 | PBFIN2 PBFIN1 | | | | | | Playback equalizer amplifier input (FORWARD head connected) |
| 33 38 | PBREF2 PBREF1 | 4.0V | — | O | — | | Playback equalizer amplifier reference (Vcc/2 output) |

| Pin No. | Symbol | Typical pin voltage | | I/O | I/O resistance | Equivalent circuit | Description |
|---------------|--------|---------------------|----|-----|----------------|--------------------|---|
| | | DC | AC | | | | |
| 35 | VCT | 4.0V | — | O | — | | Center (Vcc/2 output) |
| 36 | PBGND | 0.0V | — | — | — | | Playback equalizer amplifier ground (Connect to ground.) |
| 9 15 22 | NC | — | — | — | — | | No connected |

Electrical Characteristics

(Ta = 25°C, V_{CC} = 8.0V, DV_{CC} = 5.0V)

| Item | Symbol | Measurement conditions | Min. | Typ. | Max. | Unit |
|---|------------------|---|-------|-------|-------|------|
| Operating voltage | Vopr | | 7.8 | 8.0 | 11.0 | V |
| Current consumption | Icc | No signal, NR OFF, TAPE, 120μs, MS ON | 7.6 | 11.6 | 15.6 | mA |
| Dolby NR (0dB = Dolby level LINEOUT of -6dBm) | | | | | | |
| TAPEIN input sensitivity | V _{TIN} | TAPEIN 1kHz, LINEOUT 0dB, NR OFF | -32.0 | -30.0 | -28.0 | dBm |
| AUXIN input sensitivity | V _{AUX} | AUXIN 1kHz, LINEOUT 0dB | -32.0 | -30.0 | -28.0 | dBm |
| B type decode boost characteristics 1 | BP1 | TAPEIN 500Hz, LINEOUT -25dB, NR ON | 1.4 | 2.9 | 4.4 | dB |
| B type decode boost characteristics 2 | BP2 | TAPEIN 2kHz, LINEOUT -25dB, NR ON | 5.5 | 7.0 | 8.5 | dB |
| B type decode boost characteristics 3 | BP3 | TAPEIN 5kHz, LINEOUT -25dB, NR ON | 3.9 | 5.4 | 6.9 | dB |
| B type decode boost characteristics 4 | BP4 | TAPEIN 10kHz, LINEOUT -40dB, NR ON | 9.7 | 10.4 | 11.9 | dB |
| B type decode boost characteristics 5 | BP5 | TAPEIN 10kHz, LINEOUT 0dB, NR ON | -1.1 | 0.4 | 1.9 | dB |
| Total harmonic distortion 1 | THD1 | TAPEIN 1kHz -20dBm, NR OFF, RL = 2.7kΩ | — | 0.01 | 0.2 | % |
| Total harmonic distortion 2 | THD2 | TAPEIN 1kHz -20dBm, NR ON, RL = 2.7kΩ | — | 0.04 | 0.2 | % |
| Decode S/N ratio | SN1 | No signal, NR ON, Rg = 5.1kΩ, CCIR/ARM filter used | 77.0 | 87.0 | — | dB |
| Signal handling | SH1 | TAPEIN 1kHz, NR OFF, RL = 2.7kΩ, THD = 1% | 13.0 | 14.4 | — | dB |
| Crosstalk between channels 1 | CT1 | TAPEIN 1kHz -24dBm, NR OFF, 1kHz BPF used | — | -86.0 | -70.0 | dB |
| Crosstalk between channels 2 | CT2 | AUXIN 1kHz -24dBm, 1kHz BPF used | — | -86.0 | -70.0 | dB |
| Crosstalk between TAPE and AUX | CT3 | TAPE (AUX) IN 1kHz -24dBm, NR OFF, AUX (TAPE) mode, 1kHz BPF used*1 | — | -67.0 | -65.0 | dB |
| Output DC offset voltage | Vos1 | No signal, NR OFF, difference from VCT | -0.1 | 0.0 | 0.1 | V |
| Playback Equalizer Amplifier | | | | | | |
| Playback equalizer amplifier reference output level | PBREF | PBIN 315Hz -70dBm, 120μs mode | -27.0 | -25.0 | -23.0 | dBm |
| Playback equalizer amplifier frequency response 1 | F120 | PBIN 2.7kHz -58.5dBm, 120μs mode at 315Hz | -1.5 | 0.0 | 1.5 | dB |
| Playback equalizer amplifier frequency response 2 | F70 | PBIN 4.5kHz -53.8dBm, 70μs mode at 315Hz | -1.5 | 0.0 | 1.5 | dB |
| Signal handling | SH2 | PBIN 1kHz, 120μs mode, RL = 2.7kΩ, THD = 1% | -10.0 | -3.0 | — | dBm |
| Total harmonic distortion | THD3 | PBIN 1kHz -52dBm, 120μs mode, RL = 2.7kΩ | — | 0.07 | 0.5 | % |
| S/N ratio | SN2 | No signal, 70μs mode, Rg = 680Ω, CCIR/ARM filter used | 59.0 | 64.5 | — | dB |

| Item | Symbol | Measurement conditions | Min. | Typ. | Max. | Unit |
|---------------------------------------|------------------|---|-------|-------|------------------|------|
| Output DC offset voltage | V _{os2} | No signal, 120μs mode, R _g = 680Ω, difference from VCT | -1.0 | 0.0 | 1.0 | V |
| Crosstalk between channels | CT4 | PBIN 1kHz -42dBm, 120μs mode, 1kHz BPF used | — | -81.0 | -70.0 | dB |
| Crosstalk between FORWARD and REVERSE | CT5 | PBIN 1kHz -42dBm, 120μs mode, 1kHz BPF used | — | -80.0 | -70.0 | dB |
| Music Sensor | | | | | | |
| Signal detection level 1 | V _{MS1} | TAPEIN 5kHz, MS ON, G1 mode, external constant of 39kΩ and 0.0047μF | -43.0 | -40.0 | -37.0 | dBm |
| Signal detection level 2 | V _{MS2} | TAPEIN 5kHz, MS ON, G2 mode, external constant of 3.9kΩ and 0.47μF | -63.0 | -60.0 | -57.0 | dBm |
| MS output leak current | I _{OH} | No signal, MS OFF, G1 mode | — | 0.0 | 1.0 | μA |
| MS output saturation voltage | V _{OL} | TAPEIN 5kHz -30dBm, MS ON, G1 mode, 1mA applied to MSOUT pin | — | 0.3 | 1.0 | V |
| Logic Voltage | | | | | | |
| Low level | V _{IL} | Input voltage of NRSW, INSW, TAPESW, DRSW, MSMODE, MSSW | 0.0 | — | 0.5 | V |
| High level | V _{IH} | Input voltage of NRSW, INSW, TAPESW, DRSW, MSMODE, MSSW | 2.5 | — | DV _{CC} | V |

*1 The crosstalk between TAPE and AUX is measured with a 5.1kΩ external resistor connected to AUXIN1 (Pin 5). In this condition, the crosstalk is approximately -67dB due to the signal leak from MSLPF (Pin 6). In order to improve the crosstalk between TAPE and AUX, AUXIN1 pin should be driven with a low impedance.

Electrical Characteristics Measurement Circuit

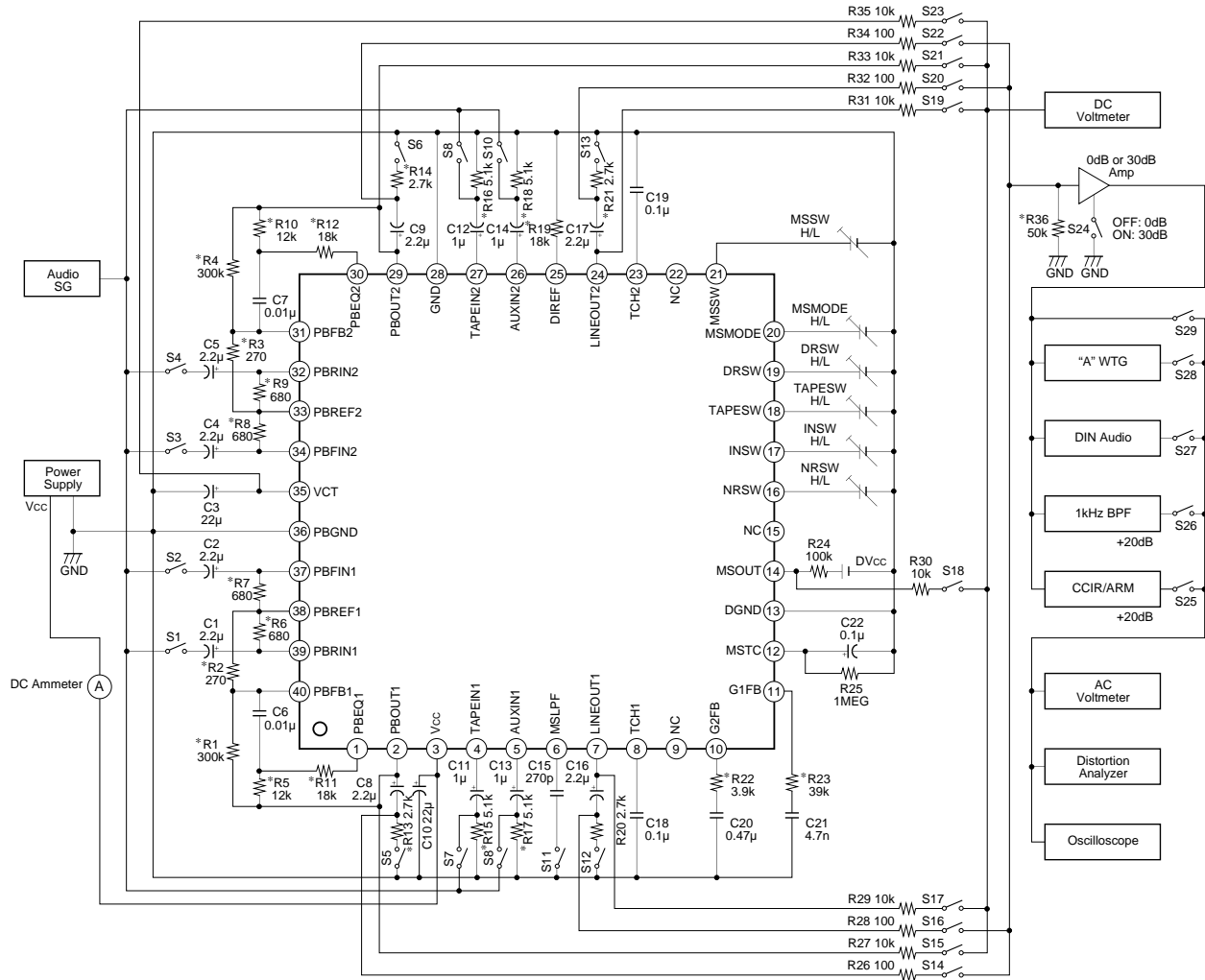

Note 1. Resistor tolerance ±5%
 *: ±1%
 2. Capacitor tolerance ±5%
 *: ±2%
 Coupling Capacitor ±10%

Application Circuit 1

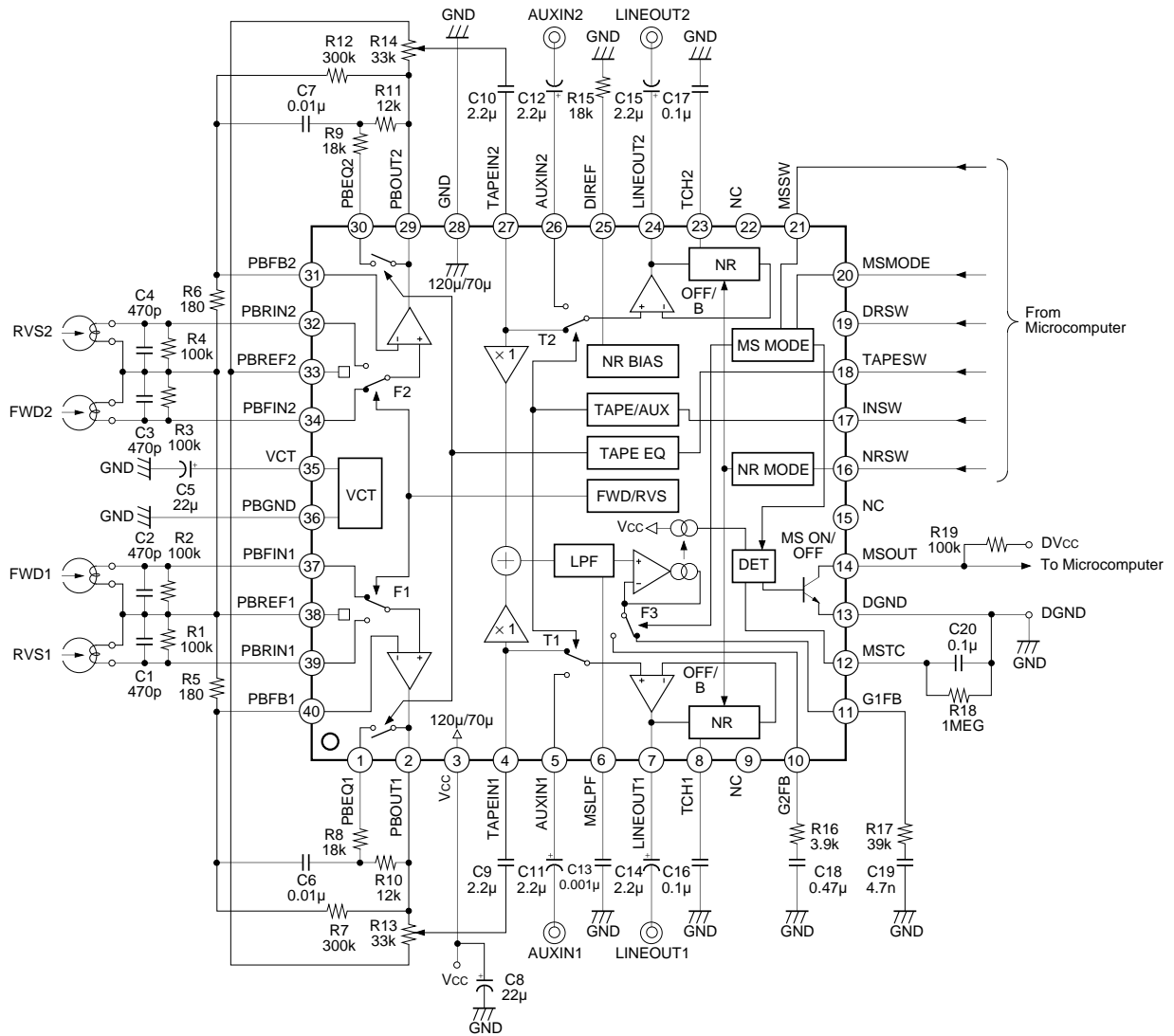

Application circuits shown are typical examples illustrating the operation of the devices. Sony cannot assume responsibility for any problems arising out of the use of these circuits or for any infringement of third party patent and other right due to same.

Application Circuit 2

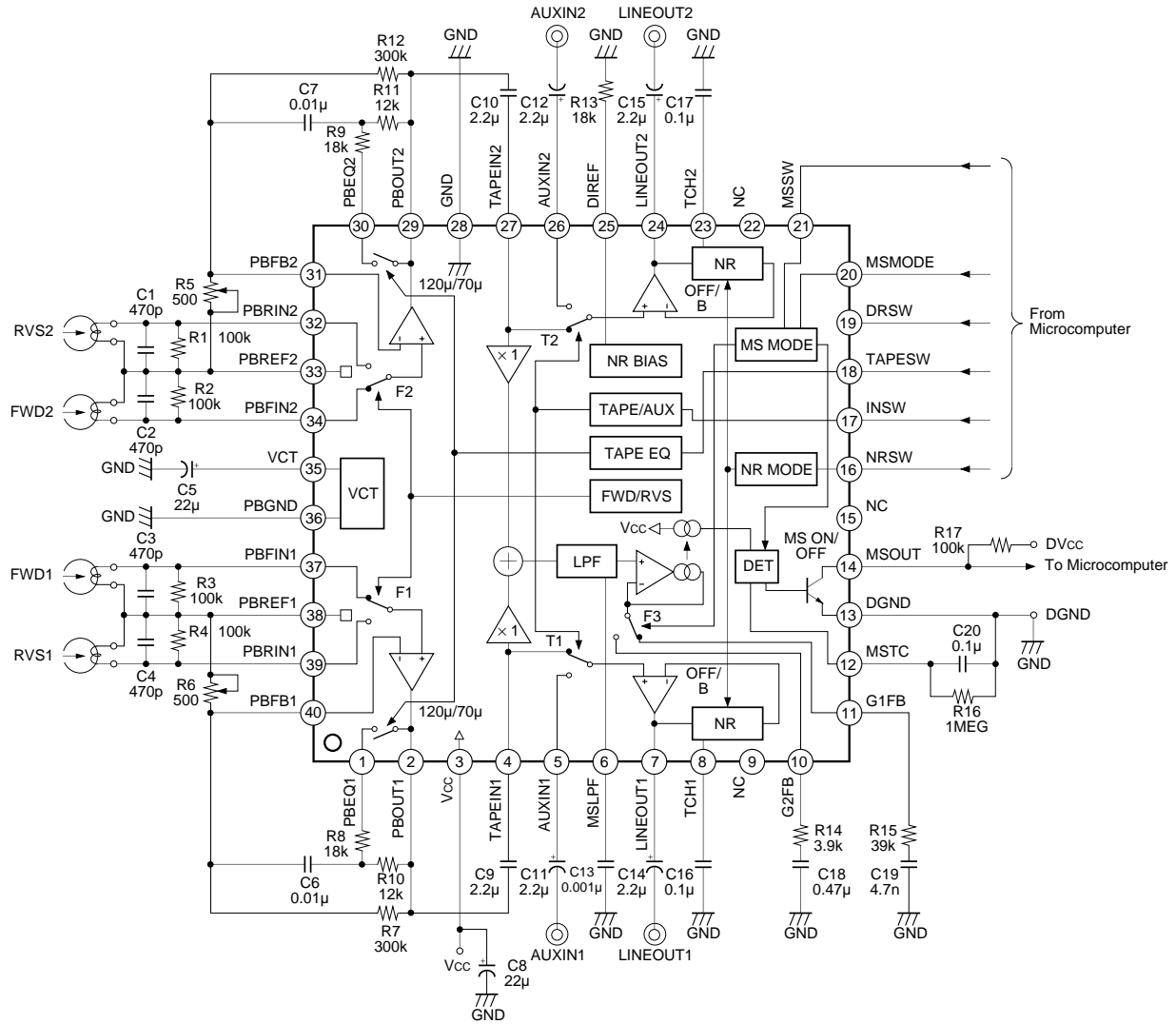

Application circuits shown are typical examples illustrating the operation of the devices. Sony cannot assume responsibility for any problems arising out of the use of these circuits or for any infringement of third party patent and other right due to same.

Description of Operation

1. Signal route

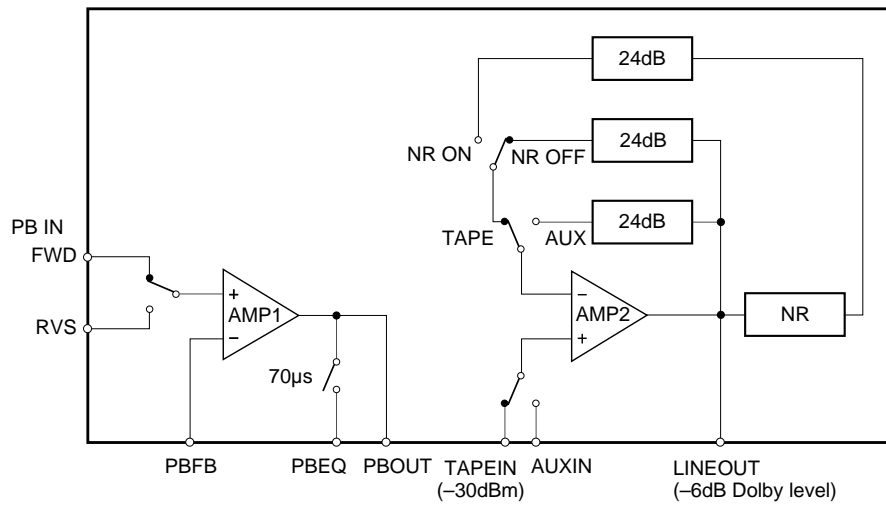

Fig. 1. Signal route block diagram

AMP1 and AMP2 are operational amplifiers. AMP1 composes the playback equalizer amplifier by attaching an external resistor and capacitor to PBF, PBEQ and PBO pins.

AMP2 is an input selector and a line amplifier. The gain is 24 dB when NR is OFF.

The Dolby NR reference level is -6dBm (LINEOUT).

2. Adjustment method

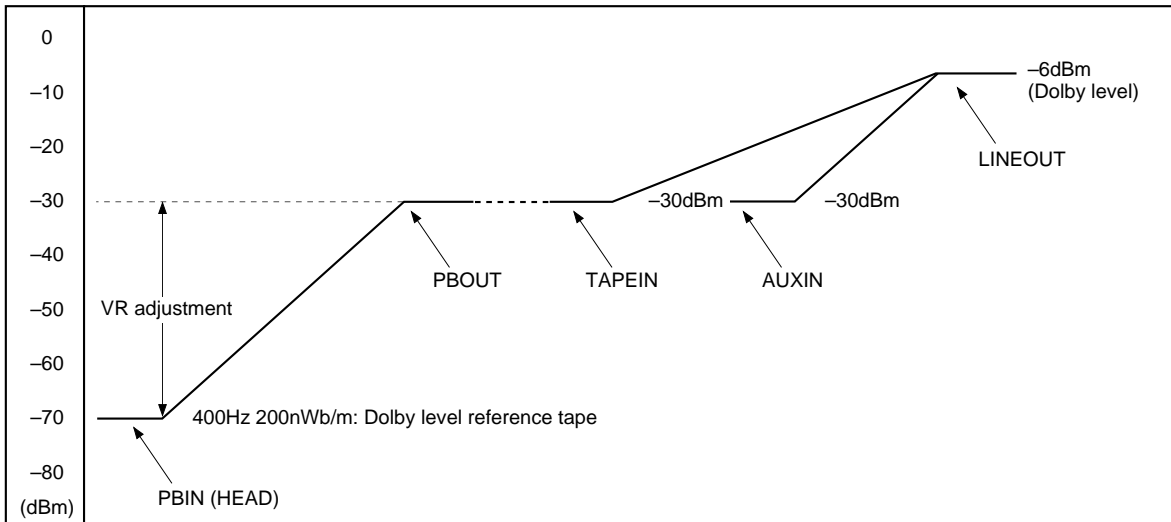

Fig. 2-1. Level diagram (application circuit 1)

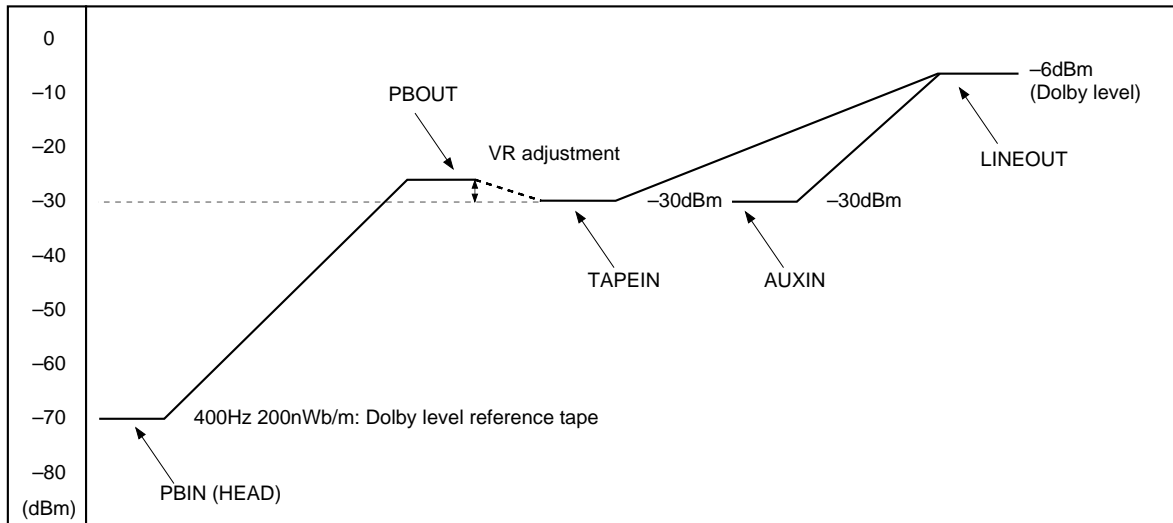

Fig. 2-2. Level diagram (application circuit 2)

Adjust the playback equalizer amplifier gain so that -6dBm (Dolby level) is output on LINEOUT (Pins 7 and 24) by playing back the reference tape for Dolby level adjustment.

Adjustment should be performed according to the rules of Dolby Laboratories Licensing Corporation because this IC has the built-in Dolby NR system.

List of Calibration Cassette Tape

Dolby level is defined as 200nWb/m measured according to the ANSI high efficiency head method.

The followings are the reference tapes specified by Dolby Laboratories Licensing Corporation.

1. A-bex Laboratories, Inc. (part no. TCC-130)
2. BASF (product code 09797 XE)
3. Kaneon Corp. (LC Engineering part no. LCT-7001)
4. Standard Tape Laboratory (catalogue no. 28)
5. TEAC Corporation, Japan (part no. MTT150)
6. TEAC Corporation of America (part no. MTT150)
7. Victor Company of Japan, Ltd. (part no. TMT-6130, VTT-727)
8. Sony Corporation (part no. TY-256)

3. Playback equalizer amplifier

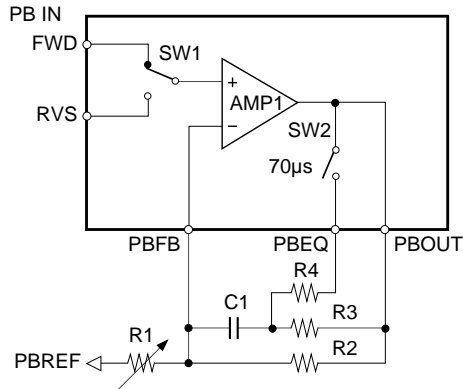

Fig. 3. Playback equalizer amplifier block diagram

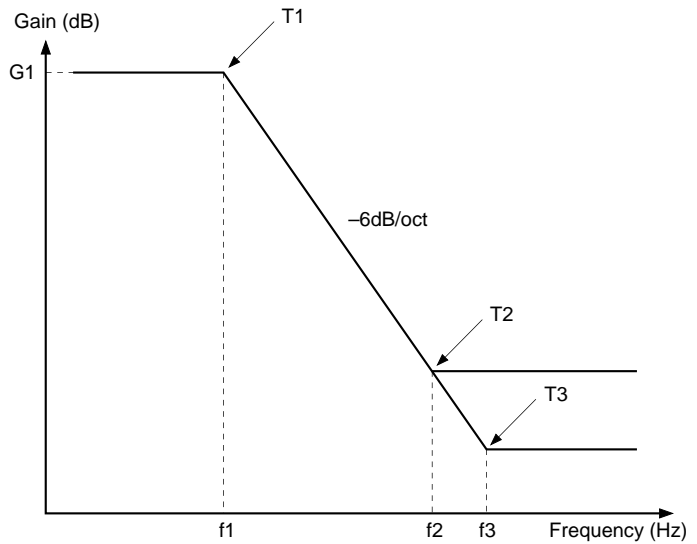

Fig. 4. Playback equalizer amplifier frequency response

The CXA2510AQ achieves the frequency response of Fig.4 with the circuit configuration shown in Fig. 3. Two systems (FORWARD and REVERSE) of playback head input are provided for each channel. The FORWARD input pin is selected when DRSW (Pin 19) is Low; REVERSE is selected when DRSW is High.

The playback equalizer amplifier frequency response can be set in two levels.

When TAPESW (Pin 18) is Low, SW2 shown in Fig. 3 is turned OFF; when TAPESW is High, SW2 is turned ON.

The external resistance R1 should be adjusted to adjust the playback equalizer amplifier gain.

The playback equalizer amplifier frequency response is all determined by the external resistance and capacitance, and it can be obtained with the following equation.

$$G(s) = \frac{R1 + R2}{R1} \cdot \frac{1 + \{s \cdot C1 \cdot (R1 \cdot R2 + R2 \cdot Rx + Rx \cdot R1) / (R1 + R2)\}}{1 + s \cdot C1 \cdot (R2 + Rx)} \quad (s = j\omega)$$

Where, Rx = R3 when TAPESW pin =Low;
 Rx = R3//R4 when TAPESW pin = High

Using the above equation, G1 in Fig. 3 and low-frequency time constant (T1) and high-frequency time constants (T2 and T3) are as follows:

$$G1 = 20\log \frac{R1 + R2}{R1}$$

$$T1 = C1 \cdot (R2 + Rx)$$

$$T2, T3 = \frac{C1 \cdot (R1 \cdot R2 + R2 \cdot Rx + Rx \cdot R1)}{R1 + R2}$$

4. Music sensor

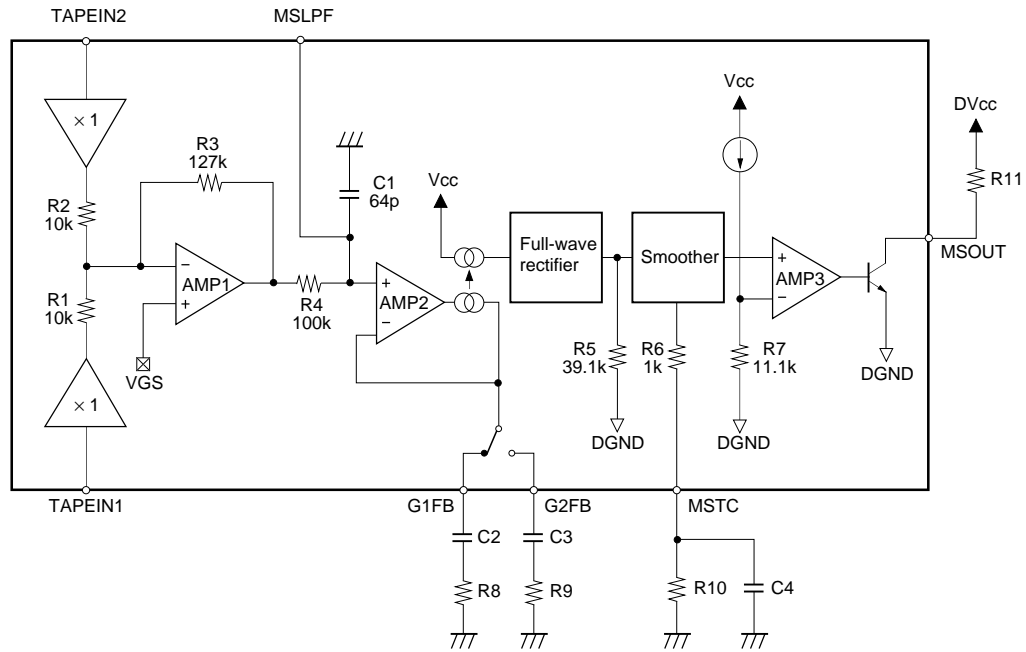

Fig. 5. Music sensor block diagram

The signal input from TAPEIN is added and amplified by AMP1. This signal is then input to the LPF (R4 and C1). The LPF cut-off frequency can be adjusted by connecting the external capacitance to MSLPF pin. The cut-off frequency is approximately 23kHz when MSLPF pin is left open. The detection level and HPF cut-off frequency are determined with the external resistance and capacitance connected to G1FB or G2FB at AMP2, and the signal is converted to a current. The signal is full-wave rectified and is converted to a voltage by the internal resistance R5. The full-wave rectified signal is smoothed. The internal resistance (R6) and external capacitance (C4) determine the smoothing response time. The recovery time is determined by the external resistance (R10) and capacitance (C4). The AMP3 comparator detects whether the smoothed signal is greater or smaller than the comparator threshold. The comparator has approximately 2dB hysteresis.

The table below shows the example of the constant and characteristics for the external resistance and capacitance connected to G1FB and G2FB.

| | R | C | Music signal detection level | Music signal interval detection level | Cut-off frequency |
|---------------|-------|----------|------------------------------|---------------------------------------|-------------------|
| FF/REW (G1) | 39kΩ | 0.0047μF | -39.5dBm | -41.4dBm | 870Hz |
| Playback (G2) | 3.9kΩ | 0.47μF | -59.5dBm | -61.4dBm | 87Hz |

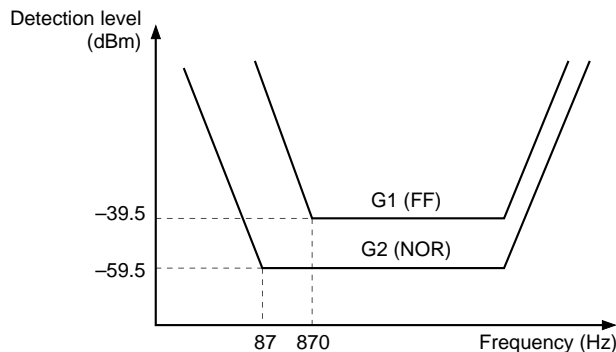

Fig. 6. Music sensor circuit frequency response

5. Operating mode control method

The CXA2510AQ has a Dolby NR switch (NRSW), playback equalizer amplifier select switch (TAPESW), head input select switch (DRSW), music sensor mode select switch (MSMODE) and music sensor switch (MSSW). The operating modes for each switch are shown in the following table.

| Pin No. | Pin name | Pin voltage | |
|---------|----------|--------------|--------------|
| | | Low (OPEN) | High |
| 16 | NRSW | Dolby NR OFF | Dolby NR ON |
| 17 | INSW | TAPE | AUX |
| 18 | TAPESW | 120 μ s | 70 μ s |
| 19 | DRSW | PBIN FORWARD | PBIN REVERSE |
| 20 | MSMODE | G1 | G2 |
| 21 | MSSW | MS ON | MS OFF |

Notes on Operation

1. Dolby NR

Dolby NR functions by using the current that flows into DIREF (Pin 25) as standard.

The Dolby NR attack/recovery time is determined by the capacitance connected to TCH (Pins 8 and 23).

Use the parts connected to these pins with high accuracy and small temperature characteristics.

(It is recommended that the resistance tolerance of 2% <metal-oxide> and capacitance tolerance of 10% <film>.)

2. Playback equalizer amplifier

All playback equalizer amplifier characteristics are determined by the external constants. Use the parts which satisfies the accuracy required for the playback equalizer amplifier.

3. Music sensor

The current on DIREF (Pin 25), and the resistance and capacitance connected to G2FB (Pin 10) and G1FB (Pin 11) determine the detection level and the HPF cut-off frequency.

The response time is determined by the resistance and capacitance connected to MSTC (Pin 12).

Use the parts which satisfies the accuracy required for the music sensor.

Example of Representative Characteristics

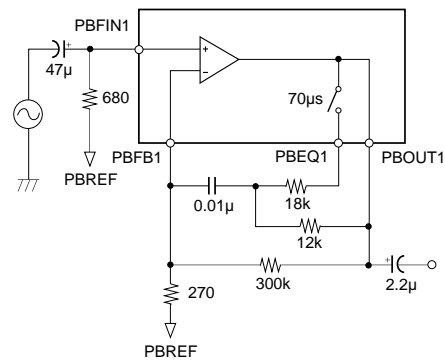
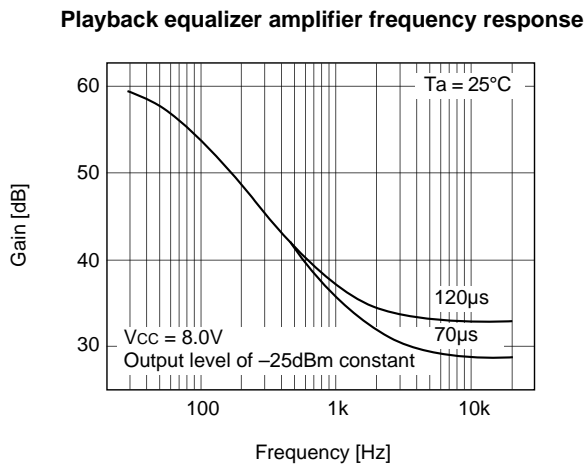
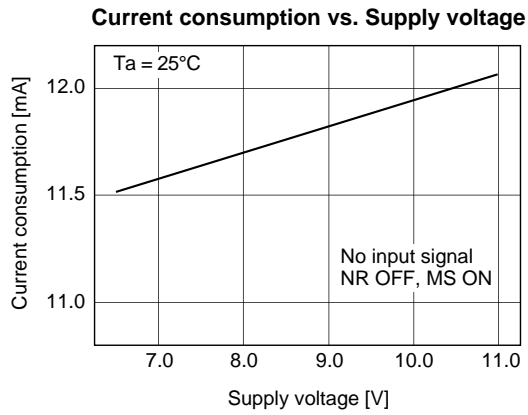
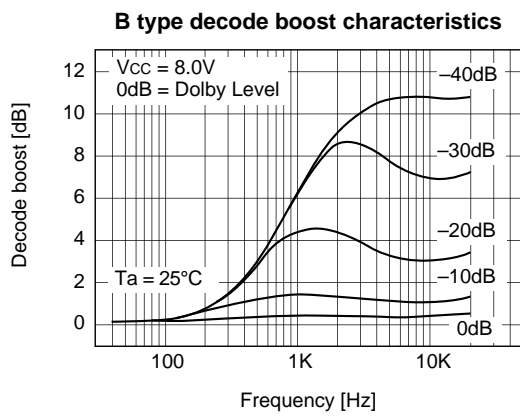
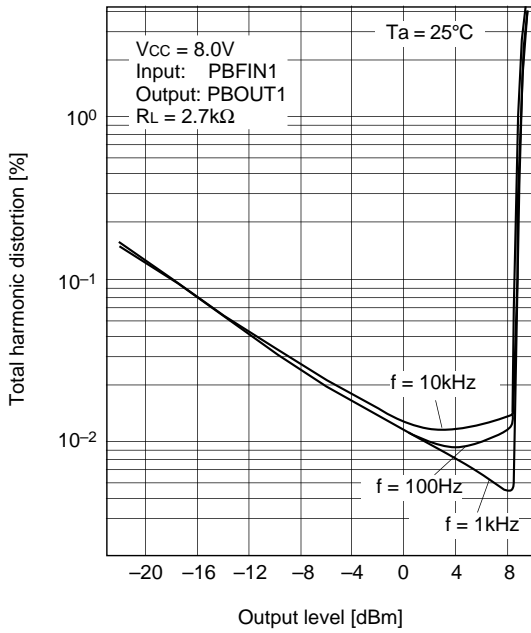

Fig. 7. Measurement circuit of playback equalizer amplifier frequency response



Total harmonic distortion (playback equalizer amplifier)



B type total harmonic distortion (including NR OFF)

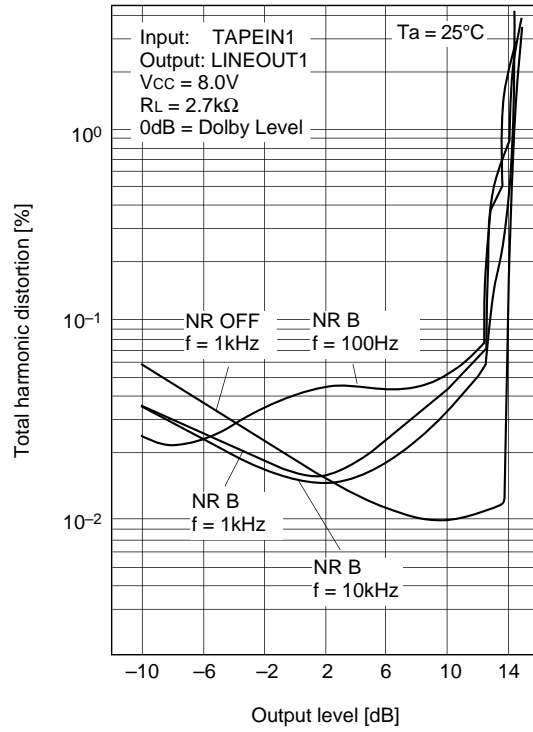

Ripple rejection ratio (PBOUT)

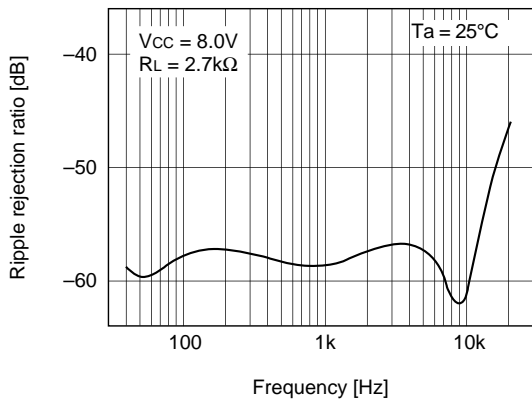

Ripple rejection ratio (LINEOUT)

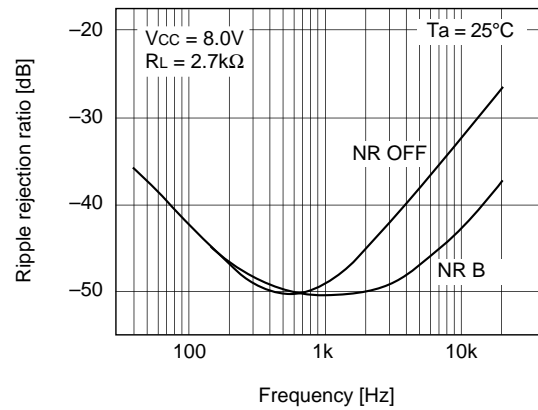

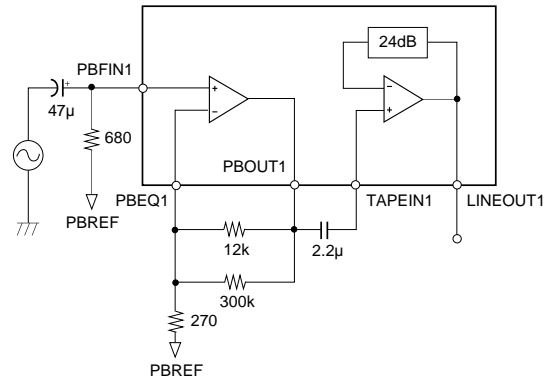
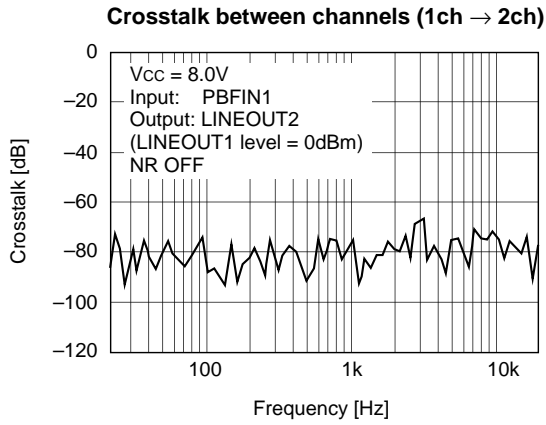
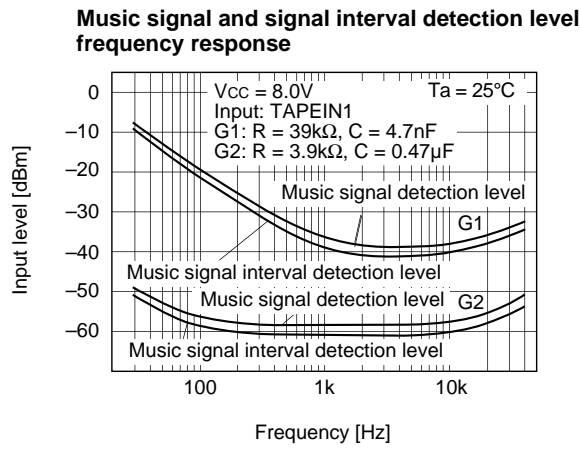

Fig. 8. Measurement circuit of crosstalk between channels



HPF connection resistance in MS block vs. Music signal and signal interval detection level characteristics

