

Playback Equalizer Amplifier with Music Sensor

Description

The CXA2559Q is an IC designed for use in car stereo cassette decks. Functions include playback equalizer amplifier and music sensor into a single chip.

Features

- Few external parts
- Small package (40-pin QFP)
- Same pin configuration as for the Dolby B-C type NR system (CXA2561Q) and Dolby B type NR system (CXA2560Q)
- Playback equalizer amplifier and music sensor into a single chip
- FORWARD/REVERSE head select switch
- Mute function
- Music signal interval detection level can be set by the external resistors/capacitors (2 modes).
- High-frequency cut-off of the music sensor circuit can be adjusted by the external capacitance.

Applications

- Car stereo cassette decks
- Playback-only cassette decks

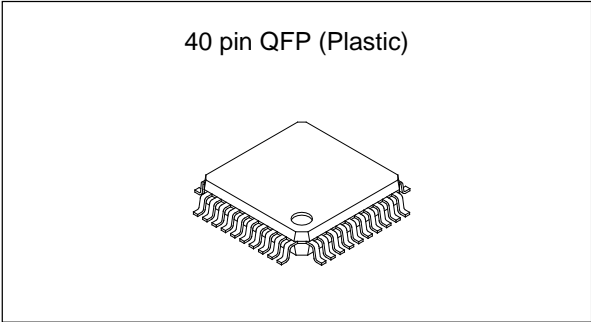

Structure

Bipolar silicon monolithic IC

Absolute Maximum Ratings

- Supply voltage V_{cc} 12 V
- Operating temperature T_{opr} -40 to +85 °C
- Storage temperature T_{stg} -65 to +150 °C
- Power dissipation P_d 430 mW

Operating Condition

- Supply voltage V_{cc} 6.5 to 11 V

Sony reserves the right to change products and specifications without prior notice. This information does not convey any license by any implication or otherwise under any patents or other right. Application circuits shown, if any, are typical examples illustrating the operation of the devices. Sony cannot assume responsibility for any problems arising out of the use of these circuits.

Block Diagram and Pin Configuration

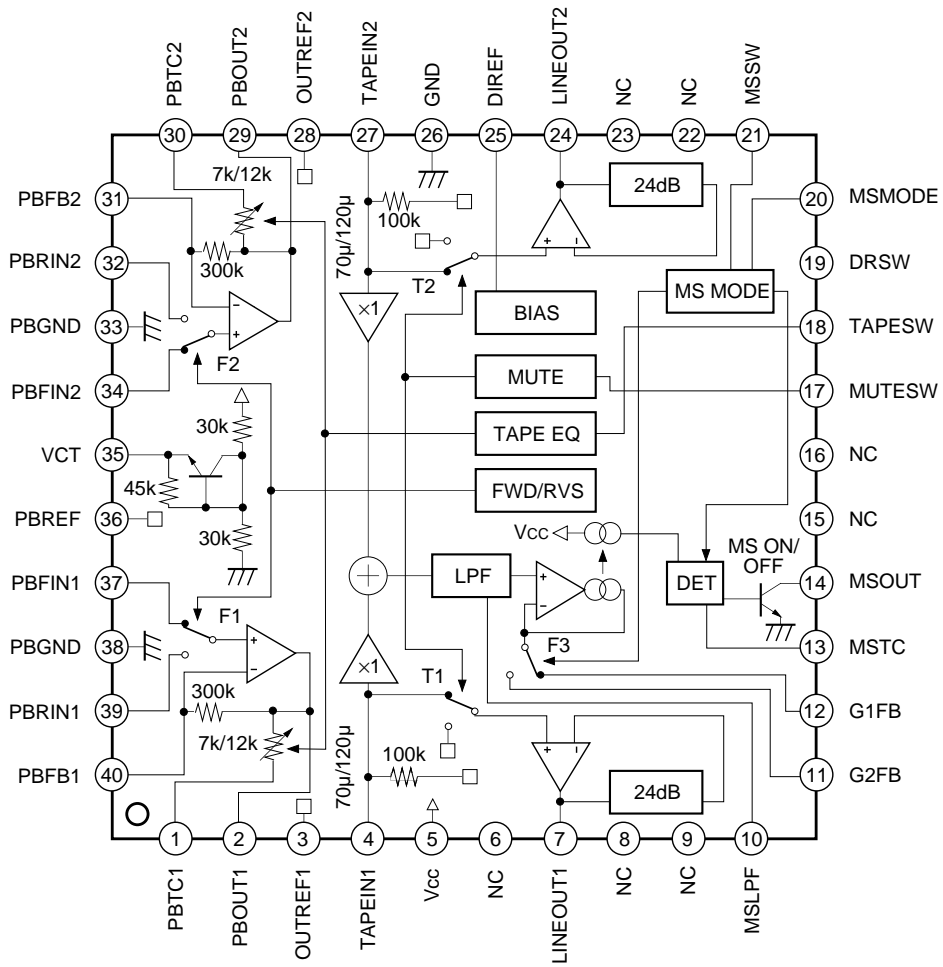

Pin Description

(Ta = 25°C, Vcc = 8.0V, DVcc = 5.0V)

Pin No.	Symbol	Typical pin voltage		I/O	I/O resistance	Equivalent circuit	Description
		DC	AC				
1 30	PBTC1 PBTC2	4.0V	—	—	—		Playback equalizer amplifier capacitance.
2 29	PBOUT1 PBOUT2	4.0V	-25dBm	O	—		Playback equalizer amplifier output.
3 28	OUTREF1 OUTREF2	4.0V	—	O	—		Output reference. (Vcc/2 output)
4 27	TAPEIN1 TAPEIN2	4.0V	-30dBm	I	100kΩ		TAPE input.
5	Vcc	8.0V	—	—	—		Power supply.

(Ta = 25°C, Vcc = 8.0V, DVcc = 5.0V)

Pin No.	Symbol	Typical pin voltage		I/O	I/O resistance	Equivalent circuit	Description
		DC	AC				
7 24	LINEOUT1 LINEOUT2	4.0V	-6dBm	O	—		Line output.
10	MSLPF	4.0V	—	—	100k		Cut-off frequency adjustment of the music sensor LPF.
11 12	G2FB G1FB	4.0V	—	—	—		Music signal interval detection level setting.
13	MSTC	—	—	—	—		Time constant for detecting the music signal interval.

(Ta = 25°C, Vcc = 8.0V, DVcc = 5.0V)

Pin No.	Symbol	Typical pin voltage		I/O	I/O resistance	Equivalent circuit	Description
		DC	AC				
14	MSOUT	0.2V when a signal is detected ; DVcc when no signal is detected	—	O	—		Music sensor output.
17	MUTESW	0.0V when open	—	I	100kΩ		Mute function control. Low (open) : Mute OFF High: Mute ON
18	TAPESW						Playback equalizer amplifier control. Low (open) : 70μs High: 120μs
21	MSSW						Music sensor control. Low (open) : MS ON High : MS OFF
19	DRSW	0.0V when open	—	I	100kΩ		Head select control. Low (open) : FORWARD High: REVERSE
20	MSMODE	0.0V when open	—	I	100kΩ		Music sensor mode control. Low (open): G1 High: G2

(Ta = 25°C, Vcc = 8.0V, DVcc = 5.0V)

Pin No.	Symbol	Typical pin voltage		I/O	I/O resistance	Equivalent circuit	Description
		DC	AC				
25	DIREF	1.2V	—	—	—		Resistance for setting the reference current. (Connects 18kΩ between DIREF pin and GND for the standard setting.)
26	GND	0.0V	—	—	—		Ground.
31 40	PBFB2 PBFB1	4.0V	-70dBm	I	—		Playback equalizer amplifier feedback.
32 39	PBRIN2 PBRIN1	4.0V	-70dBm	I	—		Playback equalizer amplifier input. (REVERSE head connected)
34 37	PBFIN2 PBFIN1						Playback equalizer amplifier input. (FORWARD head connected)
33 38	PBGND	0.0V	—	—	—	Playback equalizer amplifier ground. (Connect to GND.)	
35	VCT	4.0V	—	O	—		Center. (Vcc/2 output)

(Ta = 25°C, Vcc = 8.0V, DVcc = 5.0V)

Pin No.	Symbol	Typical pin voltage		I/O	I/O resistance	Equivalent circuit	Description
		DC	AC				
36	PBREF	4.0V	—	O	—		Playback equalizer amplifier reference. (Vcc/2 output)
6 8 9 15 16 22 23	NC	—	—	—	—		Not connected.

Electrical Characteristics

(Ta = 25°C, Vcc = 8.0V, DVcc = 5.0V)

Item	Symbol	Measurement conditions	Min.	Typ.	Max.	Unit
Operating voltage	Vopr		6.5	8.0	11.0	V
Current consumption	Icc	No signal, MUTE OFF, 70µs, MS ON	5.3	7.8	10.3	mA
Dolby NR (0dB = Line amplifier reference output level LINEOUT of -6dBm)						
TAPEIN input sensitivity	V _{TIN}	TAPEIN 1kHz, LINEOUT 0dB	-32.0	-30.0	-28.0	dBm
Total harmonic distortion 1	THD1	TAPEIN 1kHz -20dBm, RL = 2.7kΩ	-	0.01	0.2	%
S/N ratio 1	SN1	No signal, Rg = 5.1kΩ, CCIR/ARM filter used	74.0	79.4	-	dB
Signal handling	SH1	TAPEIN 1kHz, RL = 2.7kΩ, THD = 1%	13.0	14.4	-	dB
Crosstalk between channels 1	CT1	TAPEIN 1kHz -24dBm, 1kHz BPF used	-	-96.0	-70.0	dB
Mute characteristic	MUTE	TAPE IN 1kHz -24dBm, MUTE ON, 1kHz BPF used	-	-110.0	-70.0	dB
Output DC offset voltage	Vos1	No signal, difference from VCT	-0.1	0.0	0.1	V
Playback Equalizer Amplifier (PBEQ)						
Playback equalizer amplifier reference output level	PBREF	PBIN 315Hz -70dBm, 120µs mode	-27.0	-25.0	-23.0	dBm
Playback equalizer amplifier frequency response 1	F120	PBIN 2.7kHz -58.5dBm, 120µs mode at 315Hz	-1.5	0.0	1.5	dB
Playback equalizer amplifier frequency response 2	F70	PBIN 4.5kHz -53.8dBm, 70µs mode at 315Hz	-1.5	0.0	1.5	dB
Signal handling	SH2	PBIN 1kHz, 120µs mode, RL = 2.7kΩ, THD = 1%	-10.0	-3.0	-	dBm
Total harmonic distortion	THD4	PBIN 1kHz -52dBm, 120µs mode, RL = 2.7kΩ	-	0.07	0.5	%
S/N ratio	SN3	No signal, 70µs mode, Rg = 680Ω, CCIR/ARM filter used	57.0	63.5	-	dB
Output DC offset voltage	Vos2	No signal, 120µs mode, Rg = 680Ω, difference from VCT	-1.0	0.0	1.0	V
Crosstalk between channels	CT4	PBIN 1kHz -52dBm, 120µs mode, 1kHz BPF used	-	-75.0	-70.0	dB
Crosstalk between FORWARD and REVERSE	CT5	PBIN 1kHz -52dBm, 120µs mode, 1kHz BPF used	-	-80.0	-70.0	dB

Item	Symbol	Measurement conditions	Min.	Typ.	Max.	Unit
Music Sensor						
Signal detection level 1	V _{MS1}	TAPEIN 5kHz, MS ON, G1 mode, external constant of 39kΩ and 0.0047μF	-43.0	-40.0	-37.0	dBm
Signal detection level 2	V _{MS2}	TAPEIN 5kHz, MS ON, G2 mode, external constant of 3.9kΩ and 0.47μF	-63.0	-60.0	-57.0	dBm
MS output leak current	I _{OH}	No signal, MS OFF, G1 mode	-	0.0	1.0	μA
MS output saturation voltage	V _{OL}	TAPEIN 5kHz -30dBm, MS ON, G1 mode, 1mA applied to MSOUT pin	-	0.3	1.0	V
Logic Voltage						
Low level	V _{IL}	Input voltage of NRSW, MUTESW, TAPESW, DRSW, MSMODE, MSSW	0.0	-	0.8	V
High level	V _{IH}	Input voltage of NRSW, MUTESW, TAPESW, DRSW, MSMODE, MSSW	2.5	-	V _{CC}	V

Electrical Characteristics Measurement Circuit

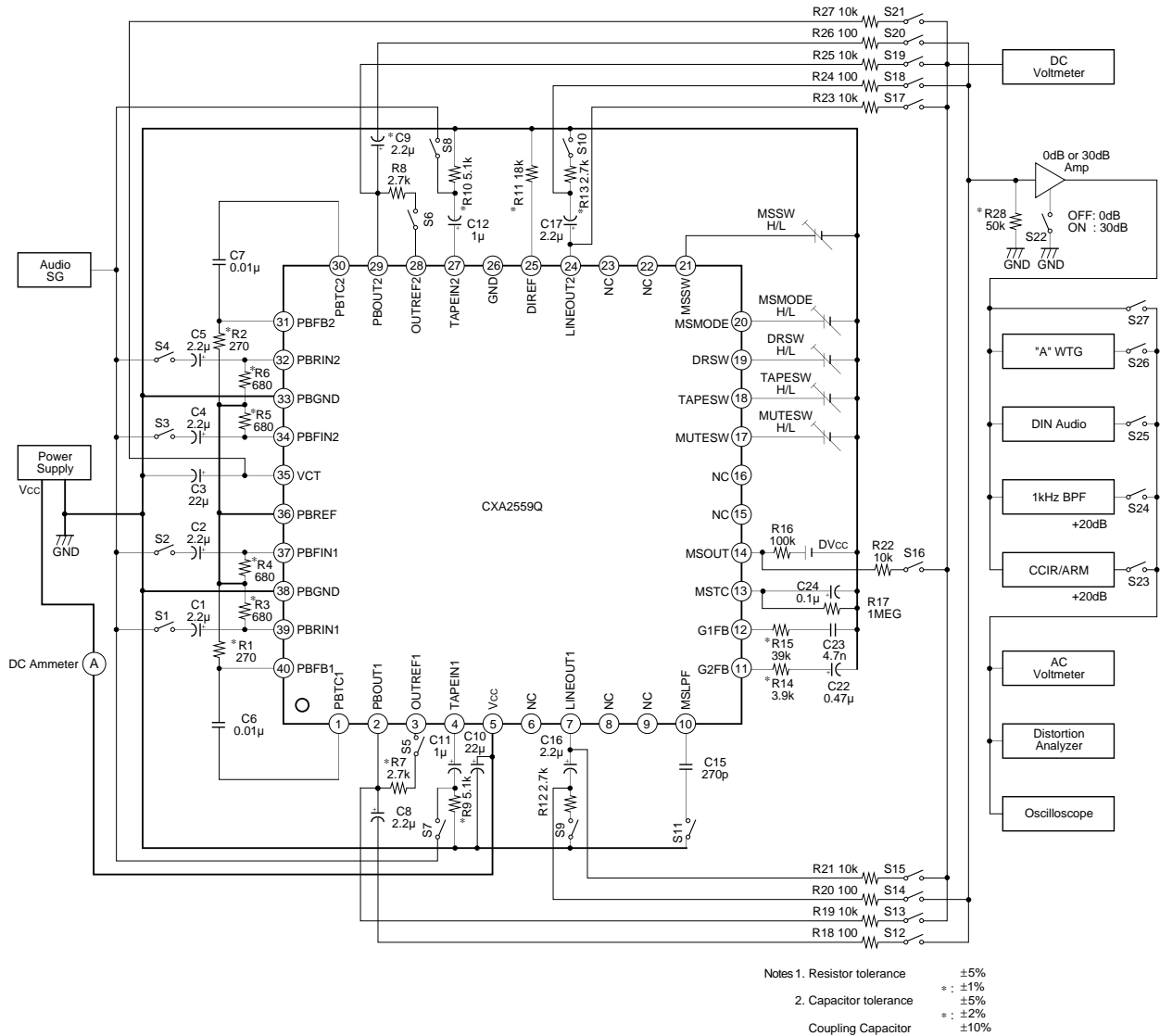

Application Circuit

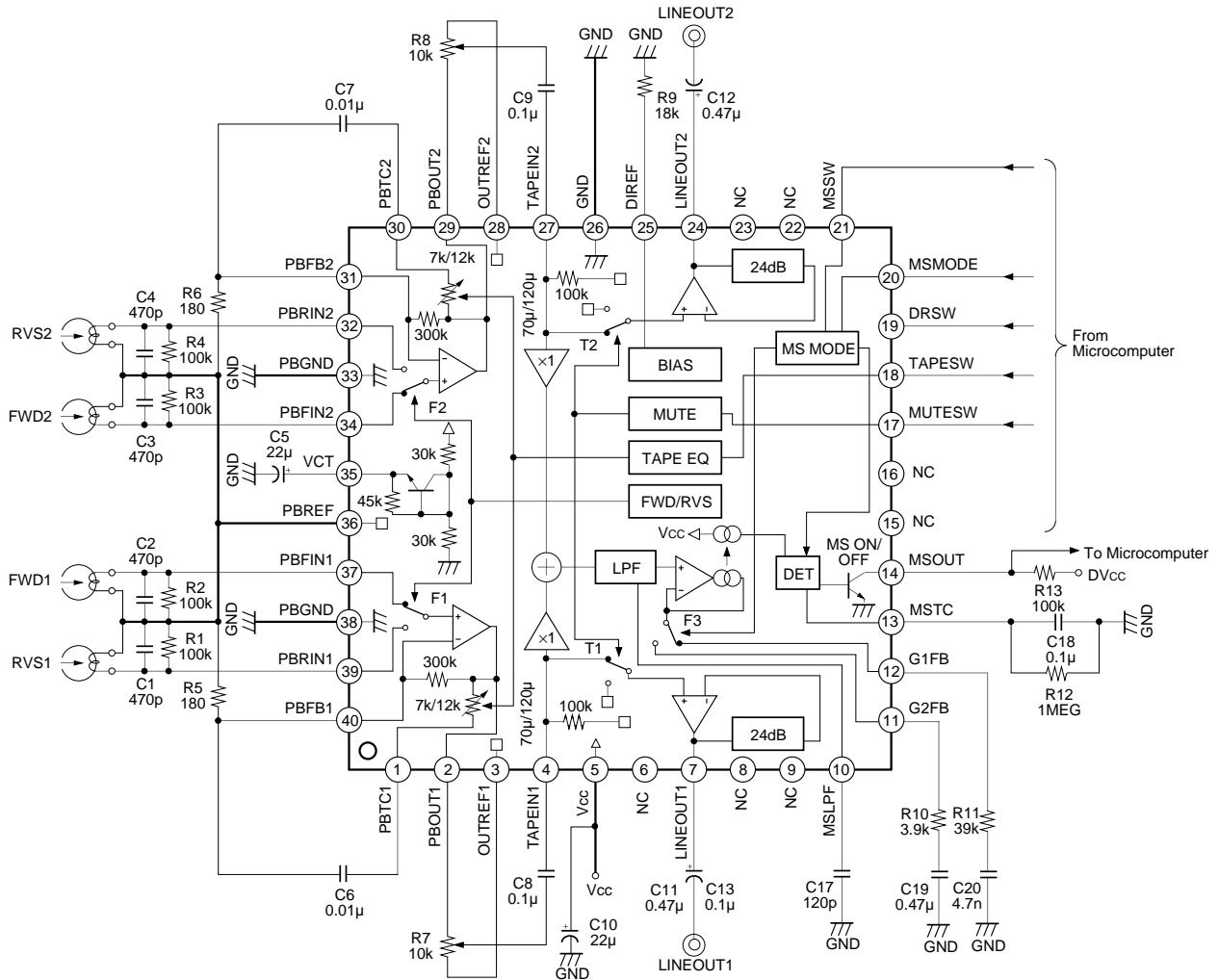

Application circuits shown are typical examples illustrating the operation of the devices. Sony cannot assume responsibility for any problems arising out of the use of these circuits or for any infringement of third party patent and other right due to same.

Description of Operation

1. Signal route

The CXA2559Q signal circuit is shown in Fig. 1.

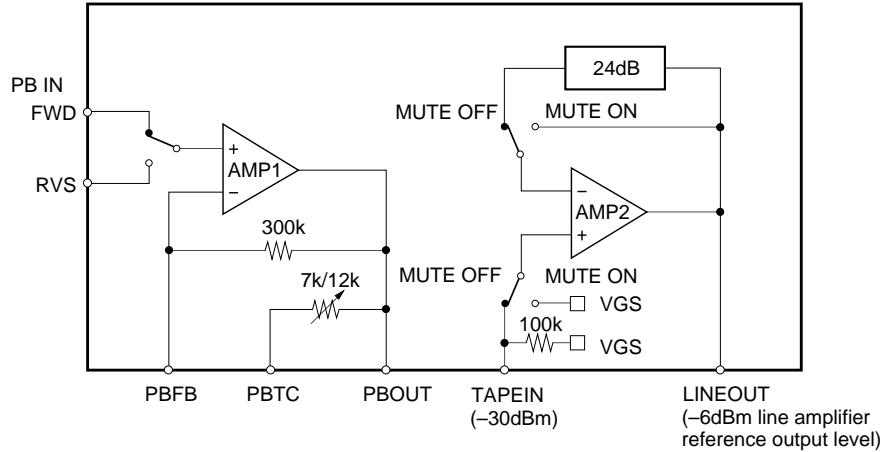

Fig. 1. Signal route block diagram

2. Gain adjustment method

Adjust the playback equalizer amplifier gain so that -6dBm is output on LINEOUT (Pins 7 and 24) by playing back the reference tape for Dolby level adjustment.

By this adjustment, the output can be the same level as for the CXA2560Q and CXA2561Q which have the built-in Dolby NR system.

Dolby level is defined as 200nWb/m measured according to the ANSI high efficiency head method.

Use the following reference tapes specified by Dolby Laboratories Licensing Corporation.

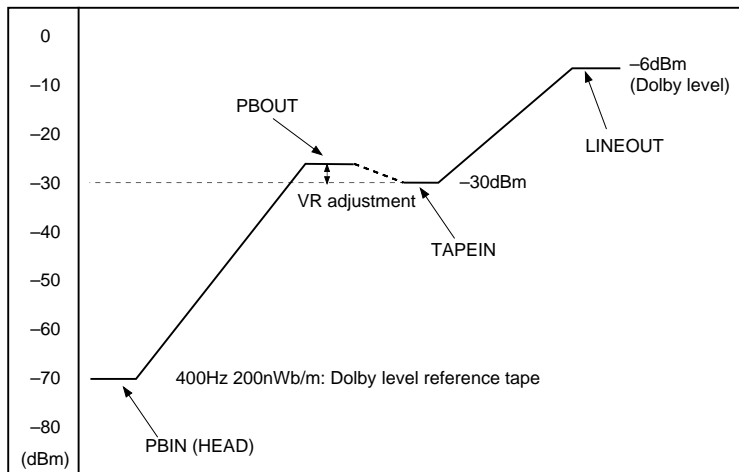

Fig. 2. Level diagram

List of Calibration Cassette Tape

1. A-bex Laboratories, Inc.
(part no. TCC-130)
2. BASF (product code 09797 XE)
3. Kaneon Corp.
(LC Engineering part no. LCT-7001)
4. Standard Tape Laboratory
(catalogue no. 28)
5. TEAC Corporation, Japan
(part no. MTT150)
6. TEAC Corporation of America
(part no. MTT150)
7. Victor Company of Japan, Ltd.
(part no. TMT-6130, VTT-727)
8. Sony Corporation (part no. TY-256)

3. Playback equalizer amplifier

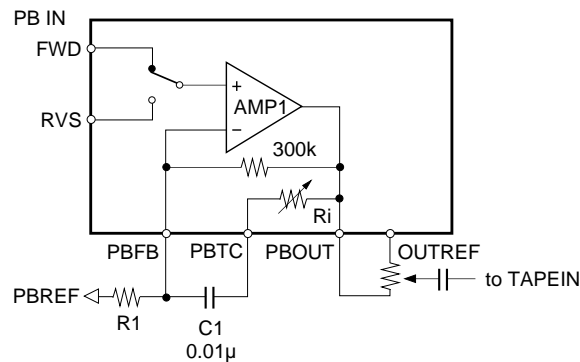

Fig. 3. Playback equalizer amplifier block diagram

The CXA2559Q configures the playback equalizer amplifier by connecting the external capacitor C1 and resistor R1 shown in Fig. 3.

Two systems (FORWARD and REVERSE) of playback head input are provided for each channel.

The FORWARD input pin is selected when DRSW (Pin 19) is Low; REVERSE is selected when DRSW is High.

The playback equalizer amplifier frequency response can be set in two levels (70µs/120µs).

When TAPESW (Pin 18) is Low, Ri is 7kΩ; when TAPESW is High, Ri is 12kΩ.

The gain can be adjusted by connecting VR between PBOUT (Pins 2 and 9) and OUTREF (Pins 3 and 28); or by using VR for the external R1.

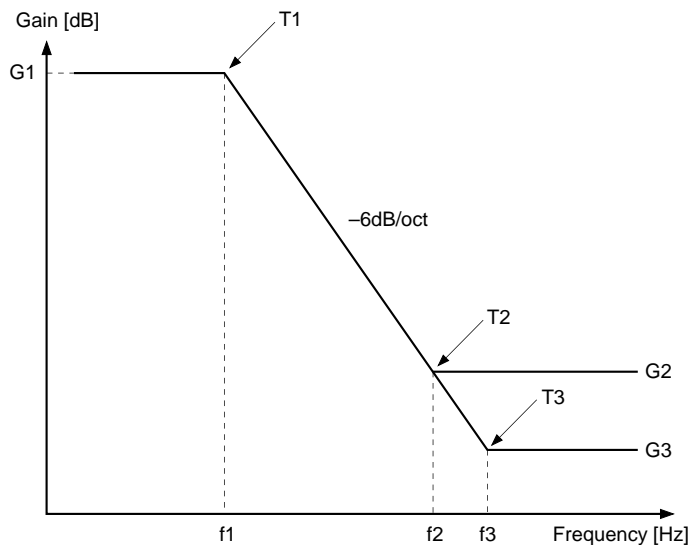

$$G1 = 20 \log \frac{R1 + 300k}{R1}$$

$$G2, G3 = 20 \log \frac{R1 + Ri // 300k}{R1}$$

$$T1 = C1 \cdot (300k + Ri)$$

$$T2, T3 = \frac{C1 \cdot (R1 \cdot 300k + 300k \cdot Ri + Ri \cdot R1)}{R1 + R2}$$

Fig. 4. Playback equalizer amplifier frequency response

4. Music sensor

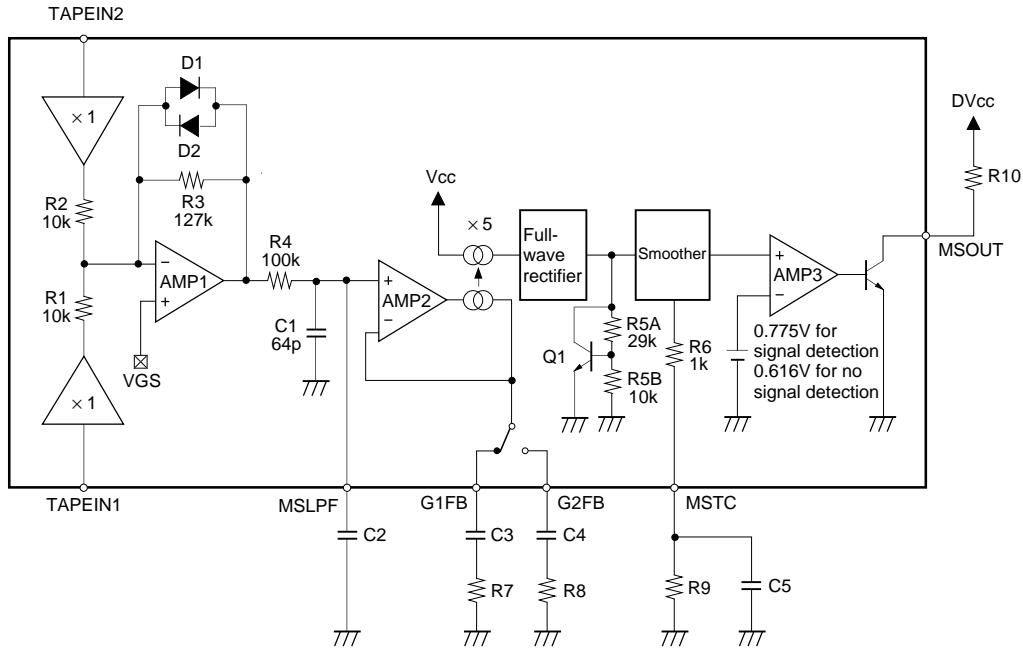

Fig. 5. Music sensor block diagram

(1) Adjustment of music signal interval detection level

Adjust the external resistors R7 and R8 to adjust the music signal interval detection level.

The signal detection level v_1 and no signal detection level v_2 are expressed by the following equations.

$$v_1 = -39 + 20 \log (39k/R_{ext}) \text{ [dBm]} \quad R_{ext}: R7 \text{ or } R8$$

$$v_2 = v_1 - 2 \text{ [dBm]}$$

(2) Low-frequency cut-off adjustment of music sensor

Adjust the external resistors R7, R8 and the external capacitors C3, C4 to adjust the low-frequency cut-off.

The low-frequency cut-off is expressed by the following equation.

$$f_{c1} = 1 / (2\pi \cdot C_{ext} \cdot R_{ext}) \quad C_{ext}, R_{ext}: C3, R7 \text{ or } C4, R8$$

(3) High-frequency cut-off adjustment of music sensor

Connect the external capacitor C2 to MSLPF (Pin 10) to adjust the high-frequency cut-off.

The high-frequency cut-off is expressed by the following equation.

$$f_{c2} = 1 / (2\pi \cdot (64p + C2) \cdot 100k)$$

The high-frequency cut-off is approximately 25kHz when MSLPF is left open .

(4) Response time adjustment

Adjust the external resistor R9 and the external capacitor C5 to adjust the response time.

The response time for signal detection depends on the internal resistor R6 and the external capacitor C5.

The response time for no signal detection depends on the external resistor R9 and the external capacitor C5.

5. Operation mode control method

The CXA2559Q has a mute switch (MUTESW), playback equalizer amplifier select switch (TAPESW), head input select switch (DRSW), music sensor mode select switch (MSMODE) and music sensor switch (MSSW). The operation modes for each switch are shown in the following table.

Pin No.	Pin name	Pin voltage	
		Low (OPEN)	High
17	MUTESW	MUTE OFF	MUTE ON
18	TAPESW	70 μ s	120 μ s
19	DRSW	PBIN FORWARD	PBIN REVERSE
20	MSMODE	G1	G2
21	MSSW	MS ON	MS OFF

Notes on Operation

1. DIREF pin resistance

The current on DIREF (Pin 25) is the reference for the playback equalizer amplifier resistor 7k Ω /12k Ω and the comparator threshold value of the music sensor.

Use the resistor with high accuracy for connecting to the DIREF pin.

(The resistance accuracy of 2% <metal-oxide> is recommended.)

2. Playback equalizer amplifier

The playback equalizer amplifier characteristics are determined by the resistor connected between the IC internal resistor and PBFB (Pins 31 and 40) and the capacitor connected between PBFB and PBTC (Pins 1 and 30). Use the parts which satisfies the accuracy required for the playback equalizer amplifier.

3. Music sensor

The resistance and capacitance connected to G2FB (Pin 11) and G1FB (Pin 12) determine the detection level and high-frequency cut-off.

The response time is determined by the resistance and capacitance connected to MSTC (Pin 13).

Use the parts which satisfies the accuracy required for the music sensor.

Example of Representative Characteristics

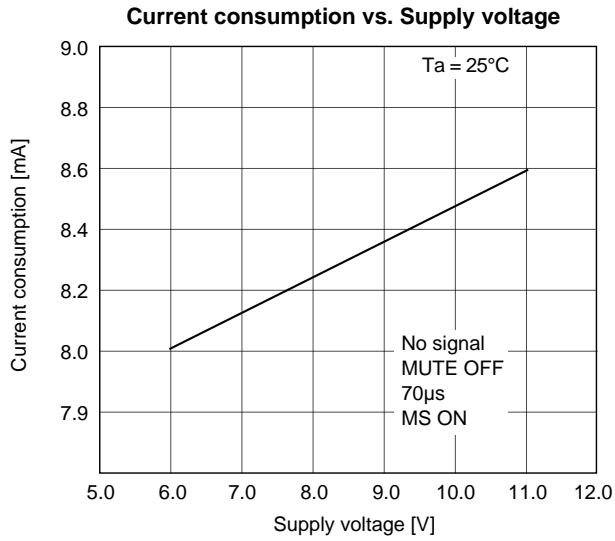

Playback equalizer amplifier frequency response

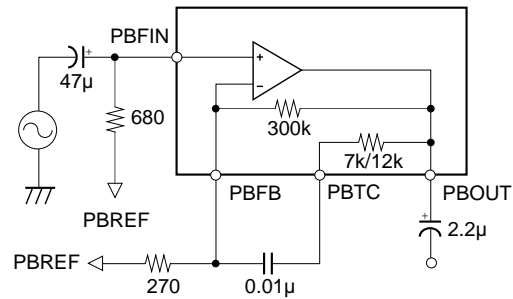
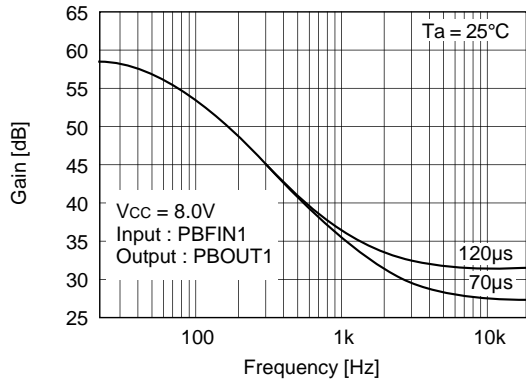
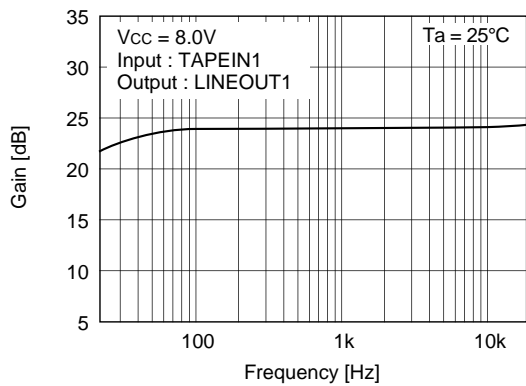
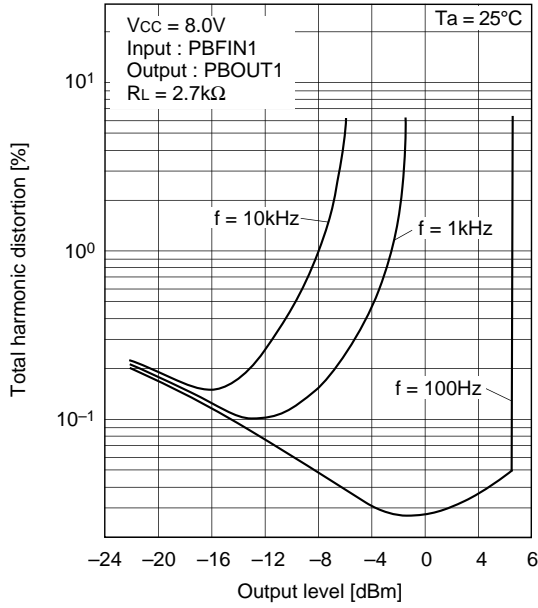

Fig. 6. Measurement circuit for playback equalizer amplifier frequency response

Line amplifier frequency response



Total harmonic distortion (playback equalizer amplifier)



Total harmonic distortion (Line amplifier)

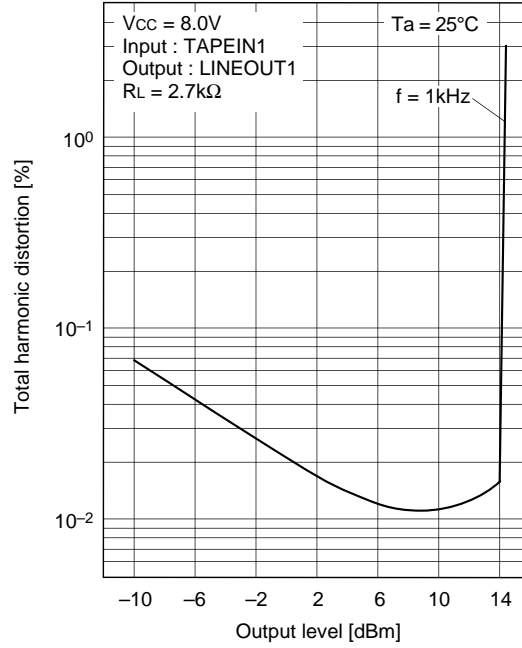

Ripple rejection ratio (PBOUT)

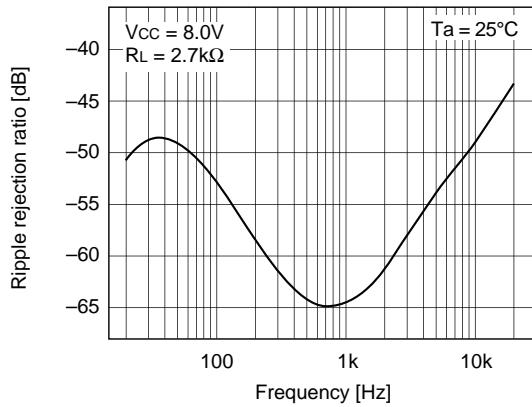

Ripple rejection ratio (LINEOUT)

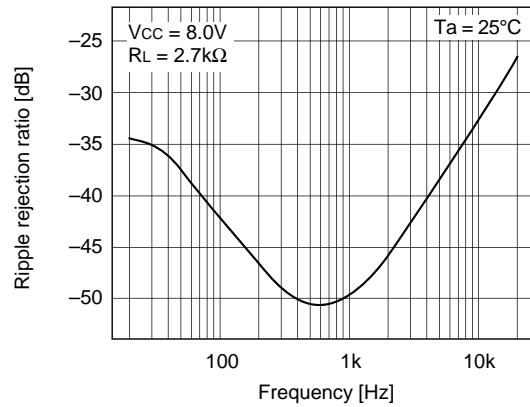

Crosstalk between channels (1ch → 2ch)

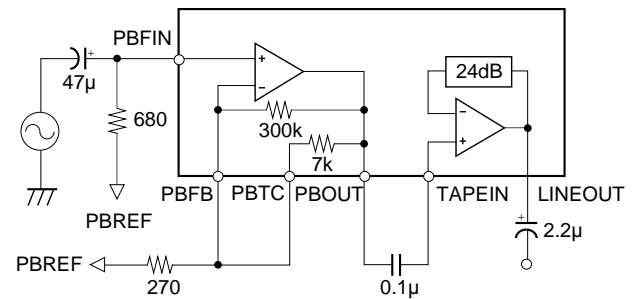
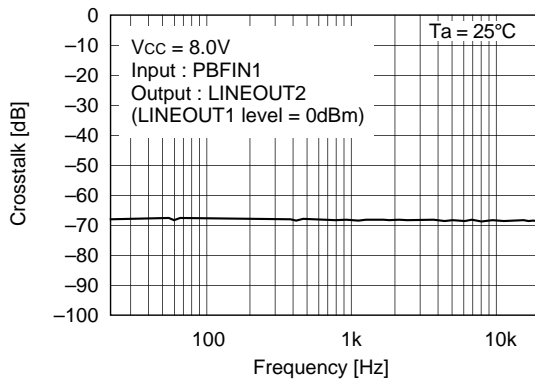
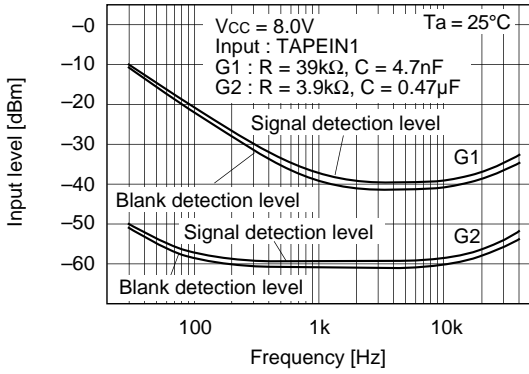
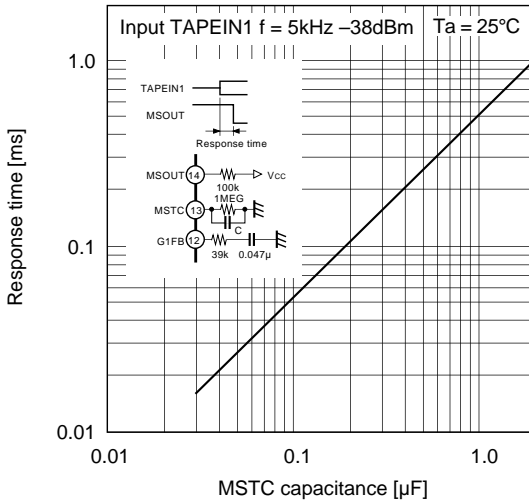

Fig. 7. Measurement circuit for crosstalk between channels

Frequency response for signal and blank detection level



Signal detection response time (G1)



Signal detection response time (G2)

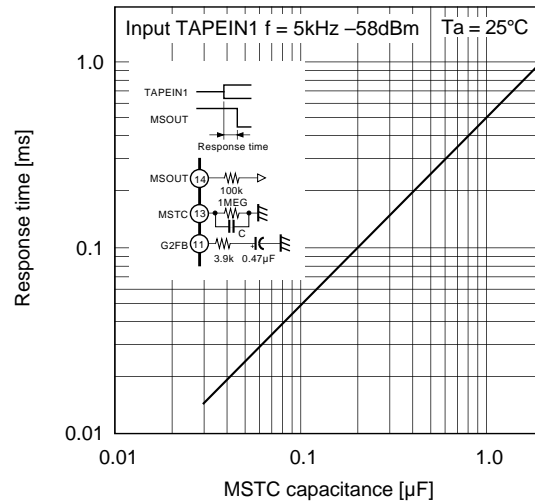

Blank detection response time (G1)

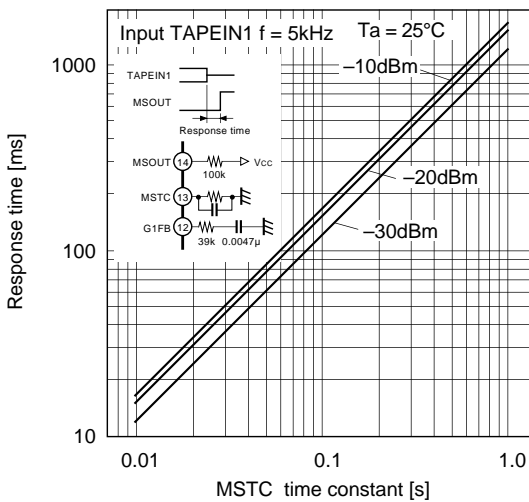

Signal detection response time (G2)

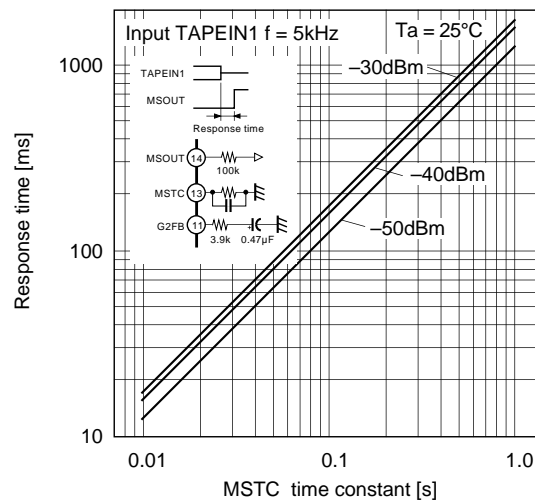

Package Outline Unit: mm

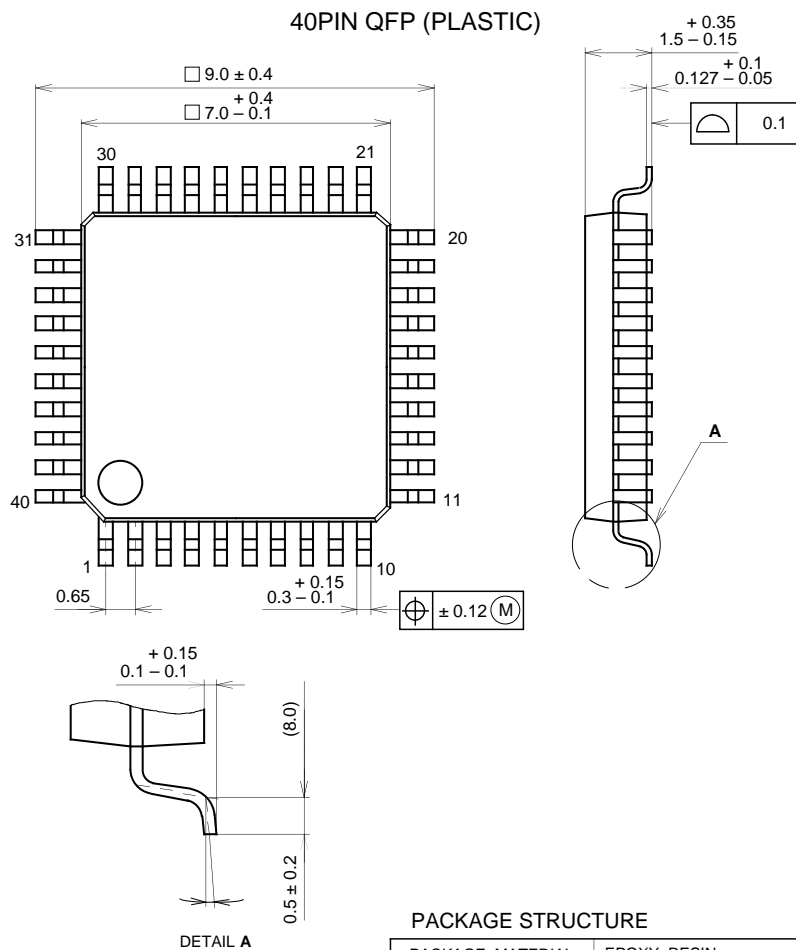

SONY CODE	QFP-40P-L01
EIAJ CODE	*QFP040-P-0707
JEDEC CODE	_____

PACKAGE STRUCTURE

PACKAGE MATERIAL	EPOXY RESIN
LEAD TREATMENT	SOLDER / PALLADIUM PLATING
LEAD MATERIAL	COPPER / 42 ALLOY
PACKAGE WEIGHT	0.2g

NOTE : PALLADIUM PLATING
 This product uses S-PdPPF (Sony Spec.-Palladium Pre-Plated Lead Frame).