

Technical Document

- [Tools Information](#)
- [FAQs](#)
- [Application Note](#)
 - [HA0075E MCU Reset and Oscillator Circuits Application Note](#)

Features

- Operating voltage:
 - f_{SYS}=4MHz: 2.2V~5.5V
 - f_{SYS}=8MHz: 3.3V~5.5V
 - f_{SYS}=12MHz: 4.5V~5.5V
- Multi-programmable Flash Type Program Memory
- EEPROM data memory: 128×8
- From 13 to 23 Bidirectional I/O with Pull-high Options
- External Interrupt Input
- Full Timer Functions with Prescaler and Interrupt
- Timer External Input
- Crystal and RC System Oscillator
- Watchdog Timer Function
- PFD/Buzzer Driver Outputs
- Power Down and Wake-up Feature for Power Saving Operation
- Up to 0.5μs instruction cycle with 8MHz system clock at V_{DD}=5V
- Bit Manipulation Instructions
- Table Read Function
- 63 Powerful Instructions
- All Instructions executed in 1 or 2 Machine Cycles
- Low Voltage Reset Function
- Flash program memory can be re-programmed up to 100,000 times
- Flash program memory data retention > 10 years
- EEPROM data memory can be re-programmed up to 1,000,000 times
- EEPROM data memory data retention > 10 years
- ISP (In-System Programming) interface
- Full Suite of Supported Hardware and Software Tools Available

General Description

The HT48F06E, HT48F10E and HT48F30E are 8-bit high-performance, RISC architecture microcontroller devices specifically designed for multiple I/O control product applications. Device flexibility is enhanced with their internal special features such as power-down and wake-up functions, oscillator options, buzzer driver, etc. These features combine to ensure applications require a minimum of external components and therefore reduce overall product costs.

Having the advantages of low-power consumption, high-performance, I/O flexibility as well as low-cost, these devices have the versatility to suit a wide range of application possibilities such as industrial control, consumer products, subsystem controllers, etc. Many fea-

tures are common to all devices, however, they differ in areas such as I/O pin count, Program Memory and Data Memory capacity, package types, etc.

All devices utilise a Flash type Program Memory, and therefore have multi-programmable capabilities offering the advantages of easy and efficient program updates. The non-volatile internal EEPROM also offers the capability of storing information such as product part numbers, calibration data and other specific product information. etc. The devices are fully supported by the Holtek range of fully functional development and programming tools, providing a means for fast and efficient product development cycles.

Selection Table

The devices include a comprehensive range of features, with most features common to all devices. The main features distinguishing them are Program Memory and Data Memory capacity, I/O count, stack size and package types. The functional differences between the devices are shown in the following table.

Part No.	VDD	Program Memory	Data Memory	Data EEPROM	I/O	8-bit Timer	Interrupt		PFD	Stack	Package Types
							Ext.	Int.			
HT48F06E	2.2V~5.5V	1K×14	64×8	128×8	13	1	1	1	√	2	16NSOP, 18DIP/SOP, 20SSOP
HT48F10E	2.2V~5.5V	1K×14	64×8	128×8	19	1	1	1	√	4	24SKDIP/SOP/SSOP
HT48F30E	2.2V~5.5V	2K×14	96×8	128×8	23	1	1	1	√	4	24SKDIP/SOP/SSOP, 28SKDIP/SOP/SSOP

Note: For devices that exist in more than one package formats, the table reflects the situation for the larger package.

Block Diagram

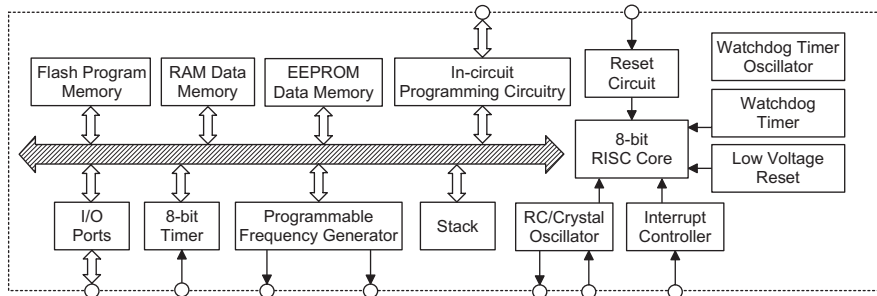

Pin Assignment

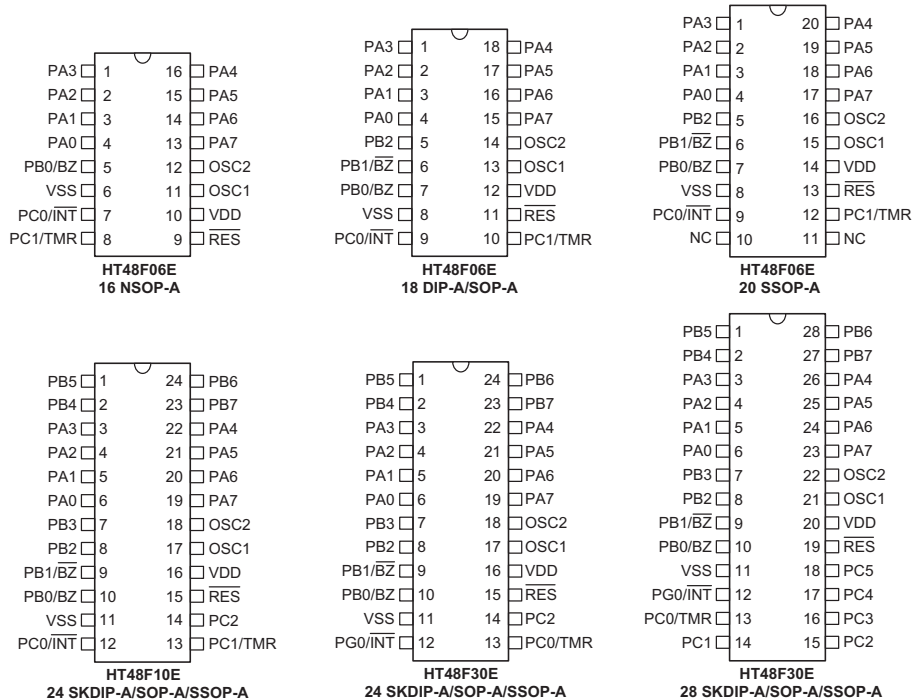

Pin Description
HT48F06E

Pad Name	I/O	Options	Description
PA0~PA7	I/O	Pull-high Wake-up	Bidirectional 8-bit input/output port. Each pin can be configured as a wake-up input by configuration option. Software instructions determine if the pin is a CMOS output or Schmitt Trigger input. A configuration option determines if all pins on this port have pull-high resistors.
PB0/BZ PB1/BZ PB2	I/O	Pull-high I/O or BZ/BZ	Bidirectional 3-bit input/output port. Software instructions determine if the pin is a CMOS output or Schmitt Trigger input. A configuration option determines if all pins on this port have pull-high resistors. Pins PB0 and PB1 are pin-shared with BZ and BZ, respectively.
PC0/INT PC1/TMR	I/O	Pull-high	Bidirectional 2-bit input/output port. Software instructions determine if the pin is a CMOS output or Schmitt Trigger input. A configuration option determines if all pins on this port have pull-high resistors. PC0 is pin-shared with the external interrupt pin INT and PC1 is pin-shared with the external timer input pin TMR.
OSC1 OSC2	I O	Crystal or RC	OSC1, OSC2 are connected to an external RC network or external crystal, determined by configuration option, for the internal system clock. If the RC system clock option is selected, pin OSC2 can be used to measure the system clock at 1/4 frequency.
RES	I	—	Schmitt trigger reset input. Active low.
VDD	—	—	Positive power supply
VSS	—	—	Negative power supply, ground.

- Note:
1. Each pin on PA can be programmed through a configuration option to have a wake-up function.
 2. Individual pins cannot be selected to have pull-high resistors. If the pull-high configuration is chosen for a particular port, then all input pins on this port will be connected to pull-high resistors.
 3. Pins PB1/BZ and PB2 do not exist on the 16-pin NSOP package type.

HT48F10E

Pin Name	I/O	Configuration Option	Description
PA0~PA7	I/O	Pull-high Wake-up Schmitt Trigger	Bidirectional 8-bit input/output port. Each pin can be configured as a wake-up input by configuration option. Software instructions determine if the pin is a CMOS output or input. Configuration options determine if all pins on this port have pull-high resistors and if the inputs are Schmitt Trigger or non-Schmitt Trigger.
PB0/BZ PB1/BZ PB2~PB7	I/O	Pull-high I/O or BZ/BZ	Bidirectional 8-bit input/output port. Software instructions determine if the pin is a CMOS output or Schmitt Trigger input. A configuration option determines if all pins on this port have pull-high resistors. Pins PB0 and PB1 are pin-shared with BZ and BZ, respectively.
PC0/INT PC1/TMR PC2	I/O	Pull-high	Bidirectional 3-bit input/output port. Software instructions determine if the pin is a CMOS output or Schmitt Trigger input. A configuration option determines if all pins on this port have pull-high resistors. Pin PC0 is pin-shared with external interrupt pin INT and PC1 shared with external timer pin TMR.
OSC1 OSC2	I O	Crystal or RC	OSC1, OSC2 are connected to an external RC network or external crystal, determined by configuration option, for the internal system clock. If the RC system clock option is selected, pin OSC2 can be used to measure the system clock at 1/4 frequency.
RES	I	—	Schmitt Trigger reset input. Active low.
VDD	—	—	Positive power supply
VSS	—	—	Negative power supply, ground

- Note:
1. Each pin on PA can be programmed through a configuration option to have a wake-up function.
 2. Individual pins cannot be selected to have pull-high resistors. If the pull-high configuration is chosen for a particular port, then all input pins on this port will be connected to pull-high resistors.

HT48F30E

Pin Name	I/O	Configuration Option	Description
PA0~PA7	I/O	Pull-high Wake-up Schmitt Trigger	Bidirectional 8-bit input/output port. Each pin can be configured as a wake-up input by configuration option. Software instructions determine if the pin is a CMOS output or input. Configuration options determine if all pins on this port have pull-high resistors and if the inputs are Schmitt Trigger or non-Schmitt Trigger.
PB0/BZ PB1/BZ PB2~PB7	I/O	Pull-high I/O or BZ/BZ	Bidirectional 8-bit input/output port. Software instructions determine if the pin is a CMOS output or Schmitt Trigger input. A configuration option determines if all pins on this port have pull-high resistors. Pins PB0 and PB1 are pin-shared with BZ and BZ, respectively.
PC0/TMR PC1~PC5	I/O	Pull-high	Bidirectional 6-bit input/output port. Software instructions determine if the pin is a CMOS output or Schmitt Trigger input. A configuration option determines if all pins on this port have pull-high resistors. PC0 is pin-shared with external timer pin TMR.
PG0/INT	I/O	Pull-high	Bidirectional 1-bit input/output port. Software instructions determine if the pin is a CMOS output or Schmitt Trigger input. A configuration option determines if the pin has a pull-high resistor. PG0 is pin-shared with external interrupt pin INT.
OSC1 OSC2	I O	Crystal or RC	OSC1, OSC2 are connected to an external RC network or external crystal, determined by configuration option, for the internal system clock. If the RC system clock option is selected, pin OSC2 can be used to measure the system clock at 1/4 frequency.
RES	I	—	Schmitt Trigger reset input. Active low.
VDD	—	—	Positive power supply
VSS	—	—	Negative power supply, ground

- Note:
- Each pin on PA can be programmed through a configuration option to have a wake-up function.
 - Individual pins cannot be selected to have pull-high resistors. If the pull-high configuration is chosen for a particular port, then all input pins on this port will be connected to pull-high resistors.
 - Pins PC1 and PC3~PC5 only exist on the 28-pin package. On the 24-pin package, these pins are not available.

Absolute Maximum Ratings

Supply Voltage	$V_{SS}-0.3V$ to $V_{SS}+6.0V$	Storage Temperature	$-50^{\circ}C$ to $125^{\circ}C$
Input Voltage	$V_{SS}-0.3V$ to $V_{DD}+0.3V$	Operating Temperature	$-40^{\circ}C$ to $85^{\circ}C$
I_{OL} Total	150mA	I_{OH} Total	$-100mA$
Total Power Dissipation	500mW		

Note: These are stress ratings only. Stresses exceeding the range specified under "Absolute Maximum Ratings" may cause substantial damage to the device. Functional operation of this device at other conditions beyond those listed in the specification is not implied and prolonged exposure to extreme conditions may affect device reliability.

D.C. Characteristics

Ta=25°C

Symbol	Parameter	Test Conditions		Min.	Typ.	Max.	Unit
		V _{DD}	Conditions				
V _{DD}	Operating Voltage	—	f _{SYS} =4MHz	2.2	—	5.5	V
		—	f _{SYS} =8MHz	3.3	—	5.5	V
		—	f _{SYS} =12MHz	4.5	—	5.5	V
I _{DD1}	Operating Current (Crystal OSC)	3V	No load, f _{SYS} =4MHz	—	0.6	1.5	mA
		5V		—	2	4	mA
I _{DD2}	Operating Current (RC OSC)	3V	No load, f _{SYS} =4MHz	—	0.8	1.5	mA
		5V		—	2.5	4	mA
I _{DD3}	Operating Current (Crystal OSC, RC OSC)	5V	No load, f _{SYS} =8MHz	—	4	8	mA
I _{STB1}	Standby Current (WDT Enabled)	3V	No load, system HALT	—	—	5	μA
		5V		—	—	10	μA
I _{STB2}	Standby Current (WDT Disabled)	3V	No load, system HALT	—	—	1	μA
		5V		—	—	2	μA
V _{IL1}	Input Low Voltage for I/O Ports	—	—	0	—	0.3V _{DD}	V
V _{IH1}	Input High Voltage for I/O Ports	—	—	0.7V _{DD}	—	V _{DD}	V
V _{IL2}	Input Low Voltage (RES)	—	—	0	—	0.4V _{DD}	V
V _{IH2}	Input High Voltage (RES)	—	—	0.9V _{DD}	—	V _{DD}	V
V _{LVR}	Low Voltage Reset	—	LVR enabled	2.7	3.0	3.3	V
I _{OL}	I/O Port Sink Current	3V	V _{OL} =0.1V _{DD}	4	8	—	mA
		5V		10	20	—	mA
I _{OH}	I/O Port Source Current	3V	V _{OH} =0.9V _{DD}	-2	-4	—	mA
		5V		-5	-10	—	mA
R _{PH}	Pull-high Resistance	3V	—	20	60	100	kΩ
		5V	—	10	30	50	kΩ

A.C. Characteristics

Ta=25°C

Symbol	Parameter	Test Conditions		Min.	Typ.	Max.	Unit
		V _{DD}	Conditions				
f _{SYS}	System Clock (RC OSC, Crystal OSC)	—	2.2V~5.5V	400	—	4000	kHz
		—	3.3V~5.5V	400	—	8000	kHz
		—	4.5V~5.5V	400	—	12000	kHz
f _{TIMER}	Timer I/P Frequency (TMR)	—	2.2V~5.5V	0	—	4000	kHz
		—	3.3V~5.5V	0	—	8000	kHz
t _{WDTOSC}	Watchdog Oscillator Period	3V	—	45	90	180	μs
		5V	—	32	65	130	μs

Symbol	Parameter	Test Conditions		Min.	Typ.	Max.	Unit
		V _{DD}	Conditions				
t _{WDT1}	Watchdog Time-out Period (WDT Internal Clock Source)	3V	Without WDT prescaler	11	23	46	ms
		5V		8	17	33	ms
t _{WDT2}	Watchdog Time-out Period (Instruction Clock Source)	—	Without WDT prescaler	—	1024	—	*t _{sys}
t _{RES}	External Reset Low Pulse Width	—	—	1	—	—	μs
t _{SST}	System Start-up Timer Period	—	Wake-up from HALT	—	1024	—	*t _{sys}
t _{LVR}	Low Voltage Reset Time	—	—	1	—	2	ms
t _{INT}	Interrupt Pulse Width	—	—	1	—	—	μs

Note: *t_{sys}=1/f_{sys}

EEPROM – A.C. Characteristics

T_a=25°C

Symbol	Parameter	V _{CC} =5V±10%		V _{CC} =2.2V±10%		Unit
		Min.	Max.	Min.	Max.	
f _{SK}	Clock Frequency	0	2	0	1	MHz
t _{SKH}	SK High Time	250	—	500	—	ns
t _{SKL}	SK Low Time	250	—	500	—	ns
t _{CSS}	CS Setup Time	50	—	100	—	ns
t _{CSH}	CS Hold Time	0	—	0	—	ns
t _{CDS}	CS Deselect Time	250	—	250	—	ns
t _{DIS}	DI Setup Time	100	—	200	—	ns
t _{DIH}	DI Hold Time	100	—	200	—	ns
t _{PD1}	DO Delay to "1"	—	250	—	500	ns
t _{PD0}	DO Delay to "0"	—	250	—	500	ns
t _{SV}	Status Valid Time	—	250	—	250	ns
t _{PR}	Write Cycle Time	—	5	—	5	ms

System Architecture

A key factor in the high-performance features of the Holtek range of microcontrollers is attributed to the internal system architecture. The range of devices take advantage of the usual features found within RISC microcontrollers providing increased speed of operation and enhanced performance. The pipelining scheme is implemented in such a way that instruction fetching and instruction execution are overlapped, hence instructions are effectively executed in one cycle, with the exception of branch or call instructions. An 8-bit wide ALU is used in practically all operations of the instruction set. It carries out arithmetic operations, logic operations, rotation, increment, decrement, branch decisions, etc. The internal data path is simplified by moving data through the Accumulator and the ALU. Certain internal registers are implemented in the Data Memory and can be directly or indirectly addressed. The simple addressing methods of these registers along with additional architectural features ensure that a minimum of external components is required to provide a functional I/O control system with maximum reliability and flexibility.

Clocking and Pipelining

The main system clock, derived from either a Crystal/Resonator or RC oscillator is subdivided into four internally generated non-overlapping clocks, T1~T4. The

Program Counter is incremented at the beginning of the T1 clock during which time a new instruction is fetched. The remaining T2~T4 clocks carry out the decoding and execution functions. In this way, one T1~T4 clock cycle forms one instruction cycle. Although the fetching and execution of instructions takes place in consecutive instruction cycles, the pipelining structure of the microcontroller ensures that instructions are effectively executed in one instruction cycle. The exception to this are instructions where the contents of the Program Counter are changed, such as subroutine calls or jumps, in which case the instruction will take one more instruction cycle to execute.

When the RC oscillator is used, OSC2 is freed for use as a T1 phase clock synchronizing pin. This T1 phase clock has a frequency of $f_{SYS}/4$ with a 1:3 high/low duty cycle.

For instructions involving branches, such as jump or call instructions, two machine cycles are required to complete instruction execution. An extra cycle is required as the program takes one cycle to first obtain the actual jump or call address and then another cycle to actually execute the branch. The requirement for this extra cycle should be taken into account by programmers in timing sensitive applications

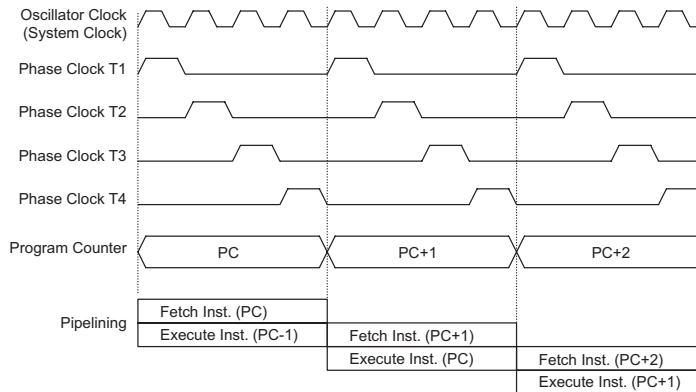

System Clocking and Pipelining

1	MOV A,[12H]
2	CALL DELAY
3	CPL [12H]
4	:
5	:
6	DELAY: NOP

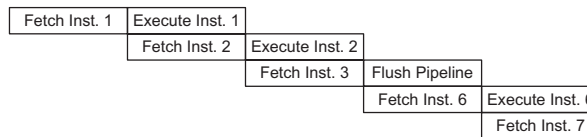

Instruction Fetching

Program Counter

During program execution, the Program Counter is used to keep track of the address of the next instruction to be executed. It is automatically incremented by one each time an instruction is executed except for instructions, such as "JMP" or "CALL", that demand a jump to a non-consecutive Program Memory address. Note that the Program Counter width varies with the Program Memory capacity depending upon which device is selected. However, it must be noted that only the lower 8 bits, known as the Program Counter Low Register, are directly addressable by user.

When executing instructions requiring jumps to non-consecutive addresses such as a jump instruction, a subroutine call, interrupt or reset, etc., the microcontroller manages program control by loading the required address into the Program Counter. For conditional skip instructions, once the condition has been met, the next instruction, which has already been fetched during the present instruction execution, is discarded and a dummy cycle takes its place while the correct instruction is obtained.

The lower byte of the Program Counter, known as the Program Counter Low register or PCL, is available for program control and is a readable and writable register. By transferring data directly into this register, a short program jump can be executed directly, however, as only this low byte is available for manipulation, the jumps are limited to the present page of memory, that is 256 locations. When such program jumps are executed it should also be noted that a dummy cycle will be inserted.

The lower byte of the Program Counter is fully accessible under program control. Manipulating the PCL might cause program branching, so an extra cycle is needed to pre-fetch. Further information on the PCL register can be found in the Special Function Register section.

Stack

This is a special part of the memory which is used to save the contents of the Program Counter only. The stack can have either 2 or 4 levels depending upon which device is selected and is neither part of the data nor part of the program space, and can neither be read from nor written to. The activated level is indexed by the Stack Pointer, SP, which can also neither be read from nor written to. At a subroutine call or interrupt acknowledge signal, the contents of the Program Counter are pushed onto the stack. At the end of a subroutine or an interrupt routine, signaled by a return instruction, RET or RETI, the Program Counter is restored to its previous value from the stack. After a device reset, the Stack Pointer will point to the top of the stack.

If the stack is full and an enabled interrupt takes place, the interrupt request flag will be recorded but the acknowledge signal will be inhibited. When the Stack Pointer is decremented, by RET or RETI, the interrupt will be serviced. This feature prevents stack overflow allowing the programmer to use the structure more easily. However, when the stack is full, a CALL subroutine instruction can still be executed which will result in a stack overflow. Precautions should be taken to avoid such cases which might cause unpredictable program branching.

Mode	Program Counter Bits										
	b10	b9	b8	b7	b6	b5	b4	b3	b2	b1	b0
Initial Reset	0	0	0	0	0	0	0	0	0	0	0
External Interrupt	0	0	0	0	0	0	0	0	1	0	0
Timer/Event Counter Overflow	0	0	0	0	0	0	0	1	0	0	0
Skip	Program Counter + 2										
Loading PCL	PC10	PC9	PC8	@7	@6	@5	@4	@3	@2	@1	@0
Jump, Call Branch	#10	#9	#8	#7	#6	#5	#4	#3	#2	#1	#0
Return from Subroutine	S10	S9	S8	S7	S6	S5	S4	S3	S2	S1	S0

Program Counter

Note: PC10~PC8: Current Program Counter bits

@7~@0: PCL bits

#10~#0: Instruction code address bits

S10~S0: Stack register bits

For the HT48F10E and the HT48F06E, since their Program Counter is 10 bits wide, the b10 column in the table is not applicable.

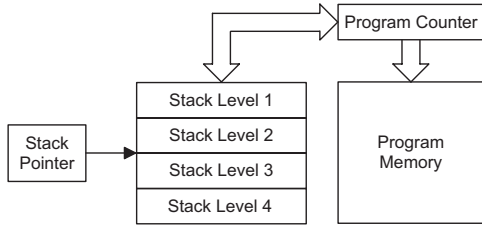

- Note:
1. For the HT48F06E, N=2, i.e. 2 levels of stack available.
 2. For the HT48F10E and HT48F30E, N=4, i.e. 4 levels of stack available.

Arithmetic and Logic Unit – ALU

The arithmetic-logic unit or ALU is a critical area of the microcontroller that carries out arithmetic and logic operations of the instruction set. Connected to the main microcontroller data bus, the ALU receives related instruction codes and performs the required arithmetic or logical operations after which the result will be placed in the specified register. As these ALU calculation or operations may result in carry, borrow or other status changes, the status register will be correspondingly updated to reflect these changes. The ALU supports the following functions:

- Arithmetic operations ADD, ADDM, ADC, ADCM, SUB, SUBM, SBC, SBCM, DAA
- Logic operations AND, OR, XOR, ANDM, ORM, XORM, CPL, CPLA
- Rotation RRA, RR, RRCA, RRC, RLA, RL, RLCA, RLC
- Increment and Decrement INCA, INC, DECA, DEC
- Branch decision JMP, SZ, SZA, SNZ, SIZ, SDZ, SIZA, SDZA, CALL, RET, RETI

Flash Program Memory

The Program Memory is the location where the user code or program is stored. For these devices the Program Memory is a Flash type, which means it can be programmed and reprogrammed a large number of times, allowing the user the convenience of code modification using the same device. By using the appropriate programming tools, these devices offer users the flexibility to conveniently debug and develop their applications while also offering a means of field programming.

Organization

The Program Memory has a capacity of 1K by 14 or 2K by 14 bits depending upon which device is selected. The Program Memory is addressed by the Program Counter and also contains data, table information and interrupt entries. Table data, which can be setup in any location within the Program Memory, is addressed by a separate table pointer register.

Special Vectors

Within the Program Memory, certain locations are reserved for special usage such as reset and interrupts.

- Location 000H
This vector is reserved for use by the device reset for program initialisation. After a device reset is initiated, the program will jump to this location and begin execution.
- Location 004H
This vector is used by the external interrupt. If the external interrupt pin on the device goes low, the program will jump to this location and begin execution if the external interrupt is enabled and the stack is not full.

	HT48F06E HT48F10E	HT48F30E
000H	Initialisation Vector	Initialisation Vector
004H	External Interrupt Vector	External Interrupt Vector
008H	Timer/Event Counter Interrupt Vector	Timer/Event Counter Interrupt Vector
00CH		
010H		
014H		
018H		
⋮		
3FFH		
400H		
⋮		
7FFH		

Not Implemented

14 bits
 14 bits

Program Memory Structure

- Location 008H
This internal vector is used by the Timer/Event Counter. If a counter overflow occurs, the program will jump to this location and begin execution if the timer/event counter interrupt is enabled and the stack is not full.

Look-up Table

Any location within the Program Memory can be defined as a look-up table where programmers can store fixed data. To use the look-up table, the table pointer must first be setup by placing the lower order address of the look up data to be retrieved in the table pointer register, TBLP. This register defines the lower 8-bit address of the look-up table.

After setting up the table pointer, the table data can be retrieved from the current Program Memory page or last Program Memory page using the "TABRDC[m]" or "TABRDL [m]" instructions, respectively. When these instructions are executed, the lower order table byte from the Program Memory will be transferred to the user defined Data Memory register [m] as specified in the instruction. The higher order table data byte from the Program Memory will be transferred to the TBLH special register. Any unused bits in this transferred higher order byte will have uncertain values.

The following diagram illustrates the addressing/data flow of the look-up table:

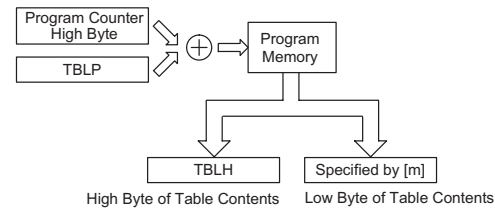

Look-up Table

Table Program Example

The following example shows how the table pointer and table data is defined and retrieved from the HT48F06E or HT48F10E devices. This example uses raw table data located in the last page which is stored there using the ORG statement. The value at this ORG statement is "300H" which refers to the start address of the last page within the 1K Program Memory of the microcontroller. The table pointer is setup here to have an initial value of "06H". This will ensure that the first data read from the data table will be at the Program Memory address "306H" or 6 locations after the start of the last page. Note that the value for the table pointer is referenced to the first address of the present page if the "TABRDC [m]" instruction is being used. The high byte of the table data which in this case is equal to zero will be transferred to the TBLH register automatically when the "TABRDL [m]" instruction is executed.

```

tempreg1 db ? ; temporary register #1
tempreg2 db ? ; temporary register #2
:
:

mov a,06h ; initialise table pointer - note that this address
; is referenced

mov tblp,a ; to the last page or present page
:
:

tabrdl tempreg1 ; transfers value in table referenced by table pointer
; to tempreg1
; data at prog. memory address "306H" transferred to
; tempreg1 and TBLH

dec tblp ; reduce value of table pointer by one

tabrdl tempreg2 ; transfers value in table referenced by table pointer
; to tempreg2
; data at prog.memory address "305H" transferred to
; tempreg2 and TBLH
; in this example the data "1AH" is transferred to
; tempreg1 and data "0FH" to register tempreg2
:
:

org 300h ; sets initial address of HT48F06E or HT48F10E last page

dc 00Ah, 00Bh, 00Ch, 00Dh, 00Eh, 00Fh, 01Ah, 01Bh
:
:

```

Because the TBLH register is a read-only register and cannot be restored, care should be taken to ensure its protection if both the main routine and Interrupt Service Routine use table read instructions. If using the table read instructions, the Interrupt Service Routines may change the value of the TBLH and subsequently cause errors if used again by the main routine. As a rule it is recommended that simultaneous use of the table read instructions should be avoided. However, in situations where simultaneous use cannot be avoided, the interrupts should be disabled prior to the execution of any main routine table-read instructions. Note that all table related instructions require two instruction cycles to complete their operation.

In Circuit Programming

The provision of Flash type Program Memory gives the user and designer the convenience of easy upgrades and modifications to their programs on the same device. As an additional convenience, Holtek has provided a means of programming the microcontroller in-circuit. This provides manufacturers with the possibility of manufacturing their circuit boards complete with a programmed or un-programmed microcontroller, and then programming or upgrading the program at a later stage. This enables product manufacturers to easily keep their manufactured products supplied with the latest program releases without removal and re-insertion of the device.

Pin Name	Function
PA0	Serial data input/output
PA4	Serial clock
RES	Device reset
VDD	Power supply
VSS	Ground

The Program Memory and EEPROM memory can both be programmed serially in-circuit using a 5-wire interface. Data is downloaded and uploaded serially on a single pin with an additional line for the clock. Two additional lines are required for the power supply and one line for the reset. The technical details regarding the

in-circuit programming of the devices are beyond the scope of this document and will be supplied in supplementary literature.

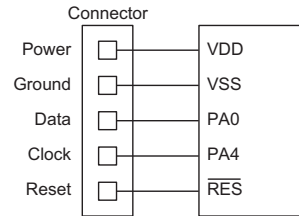

In-circuit Programming Interface

RAM Data Memory

The RAM Data Memory is a volatile area of 8-bit wide RAM internal memory and is the location where temporary information is stored. Divided into two sections, the first of these is an area of RAM where special function registers are located. These registers have fixed locations and are necessary for correct operation of the device. Many of these registers can be read from and written to directly under program control, however, some remain protected from user manipulation. The second area of RAM Data Memory is reserved for general purpose use. All locations within this area are read and write accessible under program control.

Organization

The RAM Data Memory is subdivided into two banks, known as Bank 0 and Bank 1, all of which are implemented in 8-bit wide RAM. Most of the RAM Data Memory is located in Bank 0 which is also subdivided into two sections, the Special Purpose Data Memory and the General Purpose Data Memory. The length of these sections is dictated by the type of microcontroller chosen. The start address of the RAM Data Memory for all devices is the address "00H", and the last Data Memory address is "7FH". Registers which are common to all microcontrollers, such as ACC, PCL, etc., have the same Data Memory address.

Instruction	Table Location Bits										
	b10	b9	b8	b7	b6	b5	b4	b3	b2	b1	b0
TABRDC [m]	PC10	PC9	PC8	@7	@6	@5	@4	@3	@2	@1	@0
TABRDL [m]	1	1	1	@7	@6	@5	@4	@3	@2	@1	@0

Table Location

Note: PC10~PC8: Current Program Counter bits

@7~@0: Table Pointer TBLP bits

For the HT48F30E, the Table address location is 11 bits, i.e. from b10~b0.

For the HT48F10E and the HT48F06E, the Table address location is 10 bits, i.e. from b9~b0.

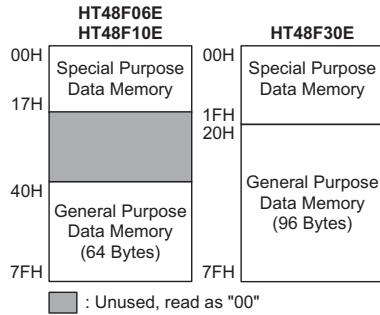
Bank 0 RAM Data Memory Structure

Bank 1 of the RAM Data Memory contains only one special function register, known as the EECR register, which is used for EEPROM control and located at address "40H" for all devices.

Bank 1 RAM Data Memory Structure

Note: Most of the RAM Data Memory bits can be directly manipulated using the "SET [m].i" and "CLR [m].i" instructions with the exception of a few dedicated bits. The RAM Data Memory can also be accessed through the Memory Pointer registers MP0 and MP1.

General Purpose Data Memory

All microcontroller programs require an area of read/write memory where temporary data can be stored and retrieved for use later. It is this area of RAM memory that is known as General Purpose Data Memory. This area of Data Memory is fully accessible by the user program for both read and write operations. By using the "SET [m].i" and "CLR [m].i" instructions individual bits can be set or reset under program control giving the user a large range of flexibility for bit manipulation in the Data Memory.

Special Purpose Data Memory

This area of Data Memory, is located in Bank 0, where registers, necessary for the correct operation of the microcontroller, are stored. Most of the registers are both readable and writable but some are protected and are readable only, the details of which are located under the relevant Special Function Register section. Note that for locations that are unused, any read instruction to these addresses will return the value "00H". Although the Special Purpose Data Memory registers are located in Bank 0, they will still be accessible even if the Bank Pointer has selected Bank 1.

	HT48F06E HT48F10E	HT48F30E
00H	IAR0	IAR0
01H	MP0	MP0
02H	IAR1	IAR1
03H	MP1	MP1
04H	BP	BP
05H	ACC	ACC
06H	PCL	PCL
07H	TBLP	TBLP
08H	TBLH	TBLH
09H	WDTS	WDTS
0AH	STATUS	STATUS
0BH	INTC	INTC
0CH		
0DH	TMR	TMR
0EH	TMRC	TMRC
0FH		
10H		
11H		
12H	PA	PA
13H	PAC	PAC
14H	PB	PB
15H	PBC	PBC
16H	PC	PC
17H	PCC	PCC
18H		
19H		
1AH		
1BH		
1CH		
1DH		
1EH		PG
1FH		PGC

Legend: : Unused, read as "00"

Special Purpose Data Memory Structure

Special Function Registers

To ensure successful operation of the microcontroller, certain internal registers are implemented in the RAM Data Memory area. These registers ensure correct operation of internal functions such as timers, interrupts, watchdog, etc., as well as external functions such as I/O data control. The location of these registers within the RAM Data Memory begins at the address "00H". Any unused Data Memory locations between these special function registers and the point where the General Purpose Memory begins is reserved for future expansion purposes, attempting to read data from these locations will return a value of "00H".

Indirect Addressing Register – IAR0, IAR1

The Indirect Addressing Registers, IAR0 and IAR1, although having their locations in normal RAM register space, do not actually physically exist as normal registers. The method of indirect addressing for RAM data manipulation uses these Indirect Addressing Registers and Memory Pointers, in contrast to direct memory addressing, where the actual memory address is specified. Actions on the IAR0 and IAR1 registers will result in no actual read or write operation to these registers but rather to the memory location specified by their corre-

sponding Memory Pointer, MP0 or MP1. Acting as a pair, IAR0 and MP0 can together only access data from Bank 0, while the IAR1 and MP1 register pair can access data from both Bank 0 and Bank 1. As the Indirect Addressing Registers are not physically implemented, reading the Indirect Addressing Registers indirectly will return a result of "00H" and writing to the registers indirectly will result in no operation.

Memory Pointer – MP0, MP1

For all devices, two Memory Pointers, known as MP0 and MP1 are provided. These Memory Pointers are physically implemented in the Data Memory and can be manipulated in the same way as normal registers providing a convenient way with which to address and track data. When any operation to the relevant Indirect Addressing Registers is carried out, the actual address that the microcontroller is directed to, is the address specified by the related Memory Pointer. MP0, together with Indirect Addressing Register, IAR0, are used to access data from Bank 0 only, while MP1 and IAR1 are used to access data from both Bank 0 and Bank 1. Note that bit 7 of the Memory Pointers is not required to address the full memory space and will return a value of "1" if read.

The following example shows how to clear a section of four RAM locations already defined as locations adres1 to adres4.

```
data .section 'data'
adres1 db ?
adres2 db ?
adres3 db ?
adres4 db ?
block db ?
code .section at 0 'code'
org 00h

start:
    mov a,04h           ; setup size of block
    mov block,a
    mov a,offset adres1; Accumulator loaded with first RAM address
    mov mp0,a          ; setup memory pointer with first RAM address

loop:
    clr IAR0           ; clear the data at address defined by MP0
    inc mp0            ; increment memory pointer
    sdz block          ; check if last memory location has been cleared
    jmp loop

continue:
```

The important point to note here is that in the example shown above, no reference is made to specific RAM addresses.

Status Register – STATUS

This 8-bit register contains the zero flag (Z), carry flag (C), auxiliary carry flag (AC), overflow flag (OV), power down flag (PDF), and watchdog time-out flag (TO). These arithmetic/logical operation and system management flags are used to record the status and operation of the microcontroller.

With the exception of the TO and PDF flags, bits in the status register can be altered by instructions like most other registers. Any data written into the status register will not change the TO or PDF flag. In addition, operations related to the status register may give different results due to the different instruction operations. The TO flag can be affected only by a system power-up, a WDT time-out or by executing the "CLR WDT" or "HALT" instruction. The PDF flag is affected only by executing the "HALT" or "CLR WDT" instruction or during a system power-up.

The Z, OV, AC and C flags generally reflect the status of the latest operations.

- **C** is set if an operation results in a carry during an addition operation or if a borrow does not take place during a subtraction operation; otherwise C is cleared. C is also affected by a rotate through carry instruction.
- **AC** is set if an operation results in a carry out of the low nibbles in addition, or no borrow from the high nibble into the low nibble in subtraction; otherwise AC is cleared.
- **Z** is set if the result of an arithmetic or logical operation is zero; otherwise Z is cleared.
- **OV** is set if an operation results in a carry into the highest-order bit but not a carry out of the highest-order bit, or vice versa; otherwise OV is cleared.
- **PDF** is cleared by a system power-up or executing the "CLR WDT" instruction. PDF is set by executing the "HALT" instruction.

- **TO** is cleared by a system power-up or executing the "CLR WDT" or "HALT" instruction. TO is set by a WDT time-out.

In addition, on entering an interrupt sequence or executing a subroutine call, the status register will not be pushed onto the stack automatically. If the contents of the status registers are important and if the subroutine can corrupt the status register, precautions must be taken to correctly save it.

Interrupt Control Register – INTC

This 8-bit register, known as the INTC register, controls the operation of both external and internal timer interrupts. By setting various bits within this register using standard bit manipulation instructions, the enable/disable function of the external and timer interrupts can be independently controlled. A master interrupt bit within this register, the EMI bit, acts like a global enable/disable and is used to set all of the interrupt enable bits on or off. This bit is cleared when an interrupt routine is entered to disable further interrupt and is set by executing the "RETI" instruction.

Note: In situations where other interrupts may require servicing within present interrupt service routines, the EMI bit can be manually set by the program after the present interrupt service routine has been entered.

Timer/Event Counter Registers

Each device contains an 8-bit Timer/Event Counter, which has an associated register known as TMR, and is the location where the timer's 8-bit value is located. An associated control register, known as TMRC, contains the setup information for the timer.

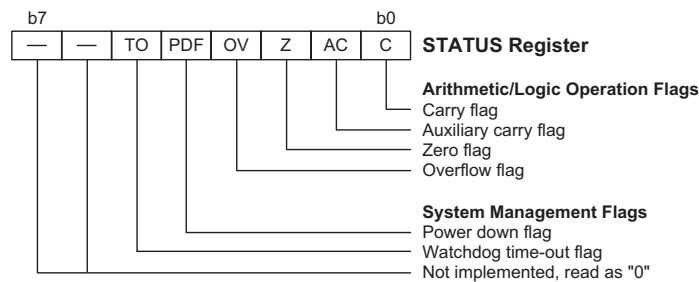

Status Register

Input/Output Ports and Control Registers

Within the area of Special Function Registers, the I/O registers and their associated control registers play a prominent role. All I/O ports have a designated register correspondingly labeled as PA, PB, PC, etc. These labeled I/O registers are mapped to specific addresses within the Data Memory as shown in the Data Memory table, which are used to transfer the appropriate output or input data on that port. With each I/O port there is an associated control register labeled PAC, PBC, PCC, etc., also mapped to specific addresses with the Data Memory. The control register specifies which pins of that port are set as inputs and which are set as outputs. To setup a pin as an input, the corresponding bit of the control register must be set high, for an output it must be set low. During program initialization, it is important to first setup the control registers to specify which pins are outputs and which are inputs before reading data from or writing data to the I/O ports. One flexible feature of these registers is the ability to directly program single bits using the "SET [m].i" and "CLR [m].i" instructions. The ability to change I/O pins from output to input and vice versa by manipulating specific bits of the I/O control registers during normal program operation is a useful feature of these devices.

EEPROM Control Register – EECR

This register is used to control all operations to and from the EEPROM Data Memory. As the EEPROM Data Memory is not mapped like the other memory types, all data to and from the EEPROM must be made through this register. The EECR register is located in Bank 1 of the Data Memory, so before use the Bank Pointer must be setup to a value of "1". The EECR register can only be read and written to indirectly using the MP1 address pointer.

EEPROM Data Memory

One of the special features within all these devices is their internal EEPROM Data Memory. EEPROM, which stands for Electrically Erasable Programmable Read Only Memory, is by its nature a non-volatile form of memory, with data retention even when its power supply is removed. By incorporating this kind of data memory a whole new host of application possibilities are made available to the designer. The availability of EEPROM

storage allows information such as product identification numbers, calibration values, specific user data, system setup data or other product information to be stored directly within the product microcontroller.

EEPROM Data Memory Structure

The internal EEPROM Data Memory has a capacity of 128x8 bits. Unlike the Program Memory and RAM Data Memory, the EEPROM Data Memory is not directly mapped and is therefore not directly accessible in the same way as the other types of memory. Instead it has to be accessed indirectly through the EEPROM Control Register.

Accessing the EEPROM Data Memory

The EEPROM Data Memory is accessed using a set of seven instructions. These instructions control all functions of the EEPROM such as read, write, erase, enable etc. The internal EEPROM structure is similar to that of a standard 3-wire EEPROM, for which four pins are used for transfer of instruction, address and data information. These are the Chip Select pin, CS, Serial Clock pin, SK, Data In pin, DI and the Data Out pin, DO. All actions related to the EEPROM must be conducted through the EECR register which is located in Bank 1 of the RAM Data Memory, in which each of these four EEPROM pins is represented by a bit in the EECR register. By manipulating these four bits in the EECR register, in accordance with the accompanying timing diagrams, the microcontroller can communicate with the EEPROM and carry out the required functions, such as reading and writing data.

Bit No.	Label	EEPROM Function
0~3	—	Not implemented bit, read as "0"
4	CS	EEPROM Data Memory select
5	SK	Serial Clock: Used to clock data into and out of the EEPROM
6	DI	Data Input: Instructions, address and data information are written to the EEPROM on this pin
7	DO	Data Output: Data from the EEPROM is readout with this bit. Will be in a high-impedance condition if no data is being read.

EECR Register - Control Bit Functions

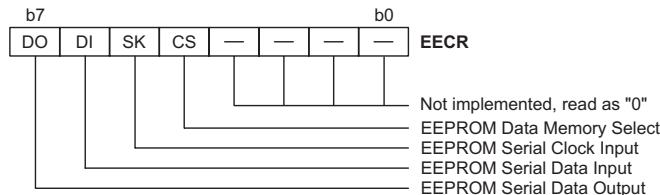

EEPROM Control Register

When reading data from the EEPROM, the data will be clocked out on the rising edge of SK and appear on DO. The DO pin will normally be in a high-impedance condition unless a READ statement is being executed. When writing to the EEPROM the data must be presented first on DI and then clocked in on the rising edge of SK. After all the instruction, address and data information has been transmitted, CS should be cleared to "0" to terminate the instruction transmission. Note that after power on the EEPROM must be initialised as described.

As indirect addressing is the only way to access the EECR register, all read and write operations to this register must take place using the Indirect Addressing Register, IAR1, and the Memory Pointer, MP1. Because the EECR control register is located in Bank 1 of the RAM Data Memory at location 40H, the MP1 Memory Pointer must first be set to the value 40H and the Bank Pointer set to "1".

EEPROM Data Memory Instruction Set

Control over the internal EEPROM, to execute functions such as read, write, disable, enable etc., is implemented through instructions of which there are a total of seven.

The related instruction is transmitted to the EEPROM via the DI bit, after CS has first been set to "1" to enable the EEPROM and a start bit "1" has been transmitted. For the READ, WRITE and ERASE instructions, each of the three instructions has its own two bit related instruction code. The 7-bit address should then be transmitted. The address is transmitted in MSB first format.

For the other four instructions, "EWEN", "EWDS", "ERAL" and "WRAL", after the start bit has been transmitted a "00" instruction code should then follow. The 7-bit address information should then follow. The first two bits of this address is instruction dependant as shown in the table while the remaining bits have don't care values and can be either high or low.

After any write or erase instruction is issued, the internal write function of the EEPROM will be used to write the data into the device. As this internal write operation uses the EEPROM's own internal clock, no further instructions will be accepted by the EEPROM until the internal write function has ended. After power on and before any instruction is issued the EEPROM must be properly initialised to ensure proper operation.

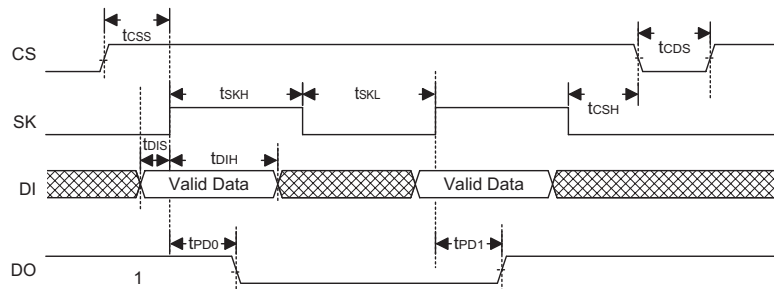

Clocking Data In and Out of the EEPROM

Instruction	Function	Start Bit	Instruction Code	Address	Data
READ	Read Out Data Byte(s)	1	10	A6~A0	D7~D0
ERASE	Erase Single Data Byte	1	11	A6~A0	—
WRITE	Write Single Data Byte	1	01	A6~A0	D7~D0
EWEN	Erase/Write Enable	1	00	11 XXXXX	—
EWDS	Erase/Write Disable	1	00	00 XXXXX	—
ERAL	Erase All	1	00	10 XXXXX	—
WRAL	Write All	1	00	01 XXXXX	D7~D0

Instruction Set Summary

READ

The "READ" instruction is used to read out one or more bytes of data from the EEPROM Data Memory. To instigate a "READ" instruction, the CS bit should be set high, followed by a high start bit and then the instruction code "10", all transmitted via the DI bit. The address information should then follow with the MSB being transmitted first. After the last address bit, A0, has been transmitted, the data can be clocked out, bit D7 first, on the rising edge of the SK clock signal and can be read via the DO bit. However, a dummy "0" bit will first precede the reading of the first data bit, D7. After the full byte has been read out, the internal address will be automatically incremented allowing the next consecutive data byte to be read out without entering further address data. As long as the CS bit remains high, data bit D7 of the next address will automatically follow data bit D0 of the previous address with no dummy "0" being inserted between them. The address will keep incrementing in this way until CS returns to a low value. DO will normally be in a high impedance condition until the "READ" instruction is executed. Note that as the "READ" instruction is not affected by the condition of the "EWEN" or "EWDS" instruction, the READ command is always valid and independent of these two instructions.

WRITE

The "WRITE" instruction is used to write a single byte of data into the EEPROM. To instigate a WRITE instruction, the CS bit should be set high, followed by a high start bit and then the instruction code "01", all transmitted via the DI bit. The address information should then follow with the MSB bit being transmitted first. After the last address bit, A0, has been transmitted, the data can be immediately transmitted MSB first. After all the WRITE instruction code, address and data have been transmitted, the data will be written into the EEPROM when the CS bit is cleared to zero. The EEPROM does this by executing an internal write-cycle, which will first erase and then write the previously transmitted data byte into the EEPROM. This process takes place internally using the EEPROM's own internal clock and does not require any action from the SK clock. No further instructions can be accepted by the EEPROM until this internal write-cycle has finished. To determine when the write cycle has ended, CS should be again brought high and the DO bit polled. If DO is low this indicates that the internal write-cycle is still in progress, however, the DO bit will change to a high value when the internal write-cycle has ended. Before a "WRITE" instruction is transmitted an "EWEN" instruction must have been transmitted at some point earlier to ensure that the erase/write function of the EEPROM is enabled.

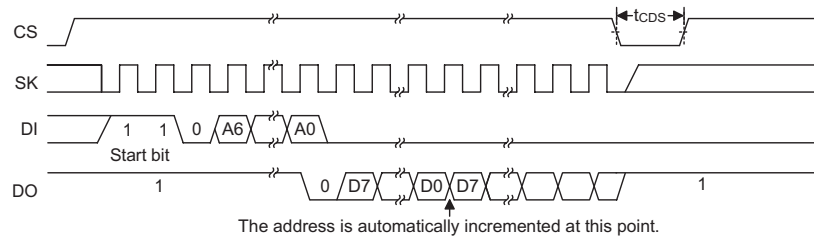

READ Timing

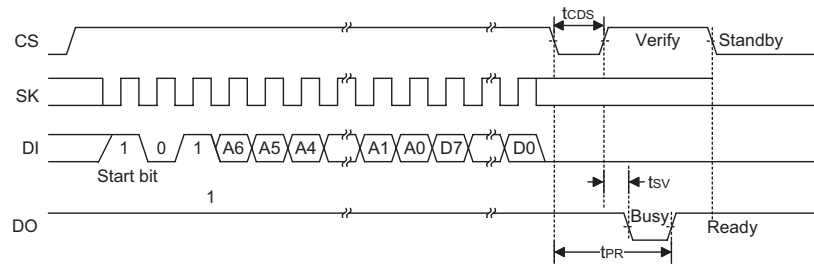

WRITE Timing

EWEN/EWDS

The "EWEN" instruction is the Erase/Write Enable instruction and the "EWDS" instruction is the Erase/Write Disable instruction. To instigate an "EWEN" or "EWDS" instruction, the CS bit should first be set high, followed by a high start bit and then the instruction code "00". For the "EWEN" instruction, a "11" should then be transmitted and for the "EWDS" instruction a "00" should be transmitted. Following on from this, 5-bits of "don't care" data should then be transmitted to complete the instruction. If the device is already in the Erase Write Disable mode then no write or erase operations can be executed thus protecting the internal EEPROM data. Before any write or erase instruction is executed an "EWEN" instruction must be issued. After the "EWEN" instruction is executed, the device will remain in the Erase Write Enable mode until a subsequent "EWDS" instruction is issued or until the device is powered down.

ERAL

The "ERAL" instruction is used to erase the whole contents of the EEPROM memory. After it has been executed all the data in the EEPROM will be set to "1". To instigate this instruction, the CS bit should be set high, followed by a high start bit and then the instruction code "00". Following on from this, a "10" should then be transmitted. This should be followed by 5-bits of "don't care" data to complete the instruction. After the "ERAL" instruction code has been transmitted, the EEPROM data will be erased when the CS bit is cleared to zero. The EEPROM does this by executing an internal write-cycle. This process takes place internally using the EEPROM's own internal clock and does not require any action from the SK clock. No further instructions can be accepted by the EEPROM until this internal write-cycle has finished. To determine when the write

cycle has ended, CS should be again brought high and the DO bit polled. If D0 is low this indicates that the internal write-cycle is still in progress, however the D0 bit will change to a high value when the internal write-cycle has ended. Before an "ERAL" instruction is transmitted an "EWEN" instruction must have been transmitted at some point earlier to ensure that the erase/write function of the EEPROM is enabled.

WRAL

The WRAL instruction is used to write the same data into the entire EEPROM. To instigate this instruction, the CS bit should be set high, followed by a high start bit and then the instruction code "00". Following on from this, a "01" should then be transmitted. This should be followed by 5-bits of "don't care" data. The data information should then follow with the MSB bit being transmitted first. After the instruction code and data have been transmitted, the data will be written into the EEPROM when the CS bit is cleared to zero. The EEPROM does this by executing an internal write-cycle. This process takes place internally using the EEPROM's own internal clock and does not require any action from the SK clock. No further instructions can be accepted by the EEPROM until this internal write-cycle has finished. To determine when the write cycle has ended, CS should be again brought high and the DO bit polled. If D0 is low this indicates that the internal write-cycle is still in progress, however the D0 bit will change to a high value when the internal write-cycle has ended. Before a "WRAL" instruction is transmitted an "EWEN" instruction must have been transmitted at some point earlier to ensure that the erase/write function of the EEPROM is enabled. The WRAL instruction will automatically erase any previously written data making it unnecessary to first issue an erase instruction.

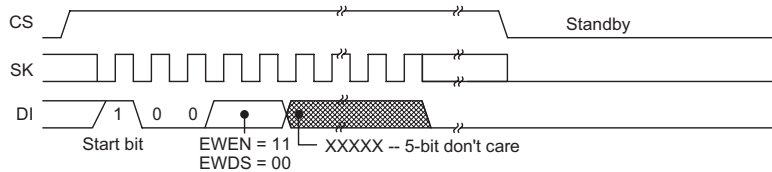

EWEN/EWDS Timing

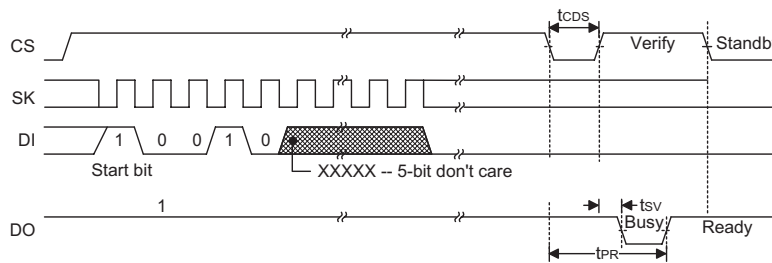

ERAL Timing

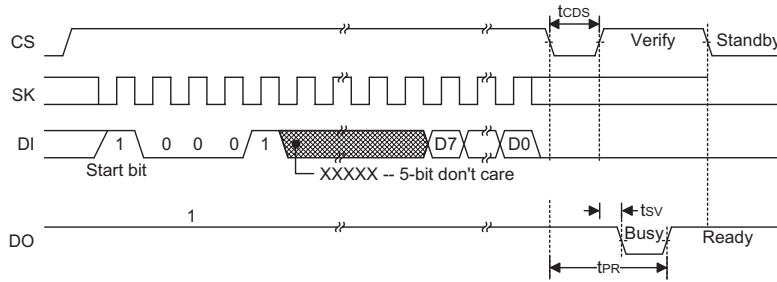

WRAL Timing

ERASE

The "ERASE" instruction is used to erase data at a specified address. The data at the address specified will be set to "1". To instigate an "ERASE" instruction, the CS bit should be set high, followed by a high start bit and then the instruction code "11", all transmitted via the DI bit. The address information should then follow with the MSB bit being transmitted first. After all the "ERASE" instruction code and address have been transmitted, the data at the specified address will be erased when the CS bit is cleared to zero. The EEPROM does this by executing an internal write cycle which will set all data at the specified address to "1". This process takes place internally using the EEPROM's own internal clock and does not require any action from the SK clock. No further instructions can be accepted by the EEPROM until the write cycle has finished. To determine when the write cycle has ended, the CS should be again brought high and the DO bit polled. If the DO bit is low this indicates that the write-cycle is still in progress, however, the DO bit will change to a high value when the write-cycle has ended. Before an "ERASE" instruction is transmitted, an "EWEN" instruction must have been transmitted at some point earlier to ensure that the erase/write function of the EEPROM is enabled.

Internal Write Cycle

The write or erase instructions, "WRITE", "ERASE", "ERAL" or "WRAL" will all use the EEPROM's internal write cycle function. As this function is completely internally timed, the SK clock is not required. As the MCU has no control over the timing of this write cycle, it must still have some way of knowing when the internal write cycle has completed. This is because, when the internal write cycle is executing, the EEPROM will not accept any further instructions from the MCU. The MCU must therefore wait until the write cycle has finished before sending any further instructions.

One way for the MCU to know when the write cycle has terminated is to poll the DO bit after the CS bit has issued a low pulse. The low going edge of this CS bit pulse will initiate the internal write cycle, when the bit is returned high the DO bit will go low to indicated that the write cycle is in progress. When the DO bit returns high this indicates that the internal write cycle has ended and that the EEPROM is ready to receive further instructions.

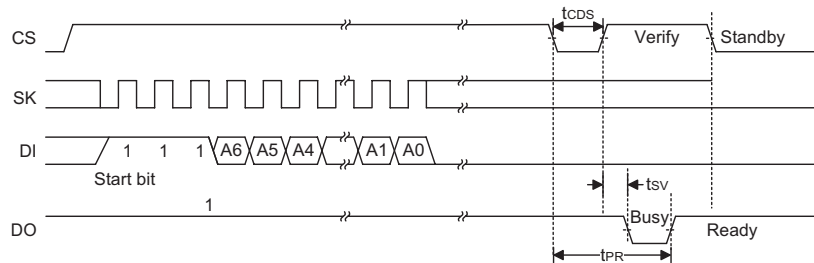

ERASE Timing

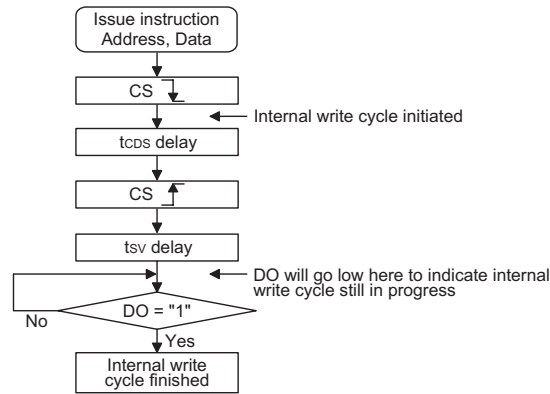
Internal Write Cycle Busy Polling

Initialising the EEPROM

After the MCU is powered on and if the EEPROM is to be used, it must be initialised in a specific way before any user instructions are transmitted. This is achieved by first transmitting an EWEN instruction, then by issuing a WRITE instruction to write random data to any sin-

gle address in the EEPROM. The initialisation procedure can then be terminated by issuing an EWDS instruction, however at this point, if actual user data is to be imminently written to the EEPROM, this last step is optional.

The following is an example program of how this can be implemented:

```

mov     A, 01h
mov     BP, A      ; set to bank 1
mov     A, 40h
mov     MP1, A     ; set MP1 to EECR address
call    EWEN      ; subroutine to run EWEN instructions
mov     A, 7Fh
mov     EEADDR, A
mov     A, 55h
mov     EEDATA, A
call    WRITE     ; subroutine to run WRITE instruction
                    ; write 55h data to address 7Fh
call    EWDS     ; optional subroutine to run EWDS instruction
  
```

EEPROM Program Examples

The following short programs gives examples of how to send instructions, read and write to the EEPROM. These programs can form a basis of understanding as to how the internal EEPROM memory is to be used to store and retrieve data.

Example 1 – Definitions and Sending Instructions to the EEPROM

```

_CS     EQU     IAR1.4      ; EEPROM lines setup to have a corresponding
_SK     EQU     IAR1.5      ; Bit in the Indirect Addressing Register IAR1
_DI     EQU     IAR1.6      ; EEPROM can only be indirectly addressed using
                    ; MP1

_DO     EQU     IAR1.7
_EECR   EQU     40H        ; Setup address of the EEPROM control register
C_Addr_Length EQU 7        ; Address length – 7-bits
C_Data_Length EQU 8        ; Data length – always 8-bits
;
DATA    .SECTION at 70h 'DATA'
EE_command DB ?            ; Stores the read or write instruction
                    ; information
ADDR     DB ?              ; Store write data or read data address
WR_Data  DB ?              ; Store read or write data
COUNT  DB ?              ; Temporary counter
;
  
```

```

WriteCommand:                                ; Write instruction code subroutine
MOV     A,3                                  ; Read, write and erase instructions are 3 bits
                                                ; long
MOV     COUNT,A
WriteCommand_0:
CLR     _DI                                  ; Prepare the transmitted bit
SZ      EE_command.7                         ; Check value of highest instruction code bit
SET     _DI
SET     _SK
CLR     _SK
CLR     C
RLC     EE_command                           ; Get next bit of instruction code
SDZ     COUNT                                ; Check if last bit has been transmitted
JMP     WriteCommand_0
CLR     _DI
RET

```

Example 2 – Transmitting an Address to the EEPROM

```

WriteAddr:                                    ; Write address subroutine
MOV     A,C_Addr_Length                      ; Setup address length
MOV     COUNT,A
WriteAddr_0:
CLR     _DI
SZ      ADDR.7                               ; Check value of address MSB
SET     _DI
CLR     C
RLC     ADDR                                  ; Get next address bit
SET     _SK
CLR     _SK
SDZ     COUNT                                ; Check if address LSB has been written
JMP     WriteAddr_0
CLR     _DI
RET

```

Example 3 – Writing Data to the EEPROM

```

WriteData:                                    ; Setup data length
MOV     A,C_Data_Length
MOV     COUNT,A
WriteData_0:
CLR     _DI
SZ      WR_Data.7                            ; Check value of data MSB
SET     _DI
CLR     C
RLC     WR_Data                               ; Get next address bit
SET     _SK
CLR     _SK
SDZ     COUNT                                ; Check if data LSB has been written
JMP     WriteData_0
CLR     _CS                                  ; CS low edge initiates internal write cycle
SET     _CS                                  ; CS high edge allows DO to be used to indicate
                                                ; end of write cycle
SNZ     _DO                                  ; Poll for DO high to indicate end of write
                                                ; cycle
JMP     $-1
RET

```

Example 4 – Reading Data from the EEPROM

```

ReadData:
    MOV    A,C_Data_Length    ; Setup data length
    MOV    COUNT,A
    CLR    WR_Data

ReadData_0:
    CLR    C
    RLC    WR_Data
    SET    _SK
    SZ     _DO                ; check value of data MSB
    SET    WR_Data.0
    CLR    _SK
    SDZ    COUNT              ; check if LSB has been received
    JMP    ReadData_0
    MOV    A,WR_Data
    RET

```

Input/Output Ports

Holtek microcontrollers offer considerable flexibility on their I/O ports. With the input or output designation of every pin fully under user program control, pull-high options for all ports and wake-up options on certain pins, the user is provided with an I/O structure to meet the needs of a wide range of application possibilities.

Depending upon which device or package is chosen, the microcontroller range provides from 13 to 23 bidirectional input/output lines labeled with port names PA, PB, PC, etc. These I/O ports are mapped to the RAM Data Memory with specific addresses as shown in the Special Purpose Data Memory table. All of these I/O ports can be used for input and output operations. For input operation, these ports are non-latching, which means the inputs must be ready at the T2 rising edge of instruction "MOV A,[m]", where m denotes the port address. For output operation, all the data is latched and remains unchanged until the output latch is rewritten.

Pull-high Resistors

Many product applications require pull-high resistors for their switch inputs usually requiring the use of an external resistor. To eliminate the need for these external resistors, all I/O pins, when configured as an input have the capability of being connected to an internal pull-high resistor. These pull-high resistors are selectable via configuration options and are implemented using a weak PMOS transistor. Note that if the pull-high option is selected, then all I/O pins on that port will be connected to pull-high resistors, individual pins cannot be selected for pull-high resistor options.

Port A Wake-up

Each device has a HALT instruction enabling the microcontroller to enter a Power Down Mode and preserve power, a feature that is important for battery and

other low-power applications. Various methods exist to wake-up the microcontroller, one of which is to change the logic condition on one of the Port A pins from high to low. After a "HALT" instruction forces the microcontroller into entering a HALT condition, the processor will remain idle or in a low-power state until the logic condition of the selected wake-up pin on Port A changes from high to low. This function is especially suitable for applications that can be woken up via external switches. Note that each pin on Port A can be selected individually to have this wake-up feature.

I/O Port Control Registers

Each I/O port has its own control register PAC, PBC, PCC, etc., to control the input/output configuration. With this control register, each CMOS output or input with or without pull-high resistor structures can be reconfigured dynamically under software control. Each pin of the I/O ports is directly mapped to a bit in its associated port control register. For the I/O pin to function as an input, the corresponding bit of the control register must be written as a "1". This will then allow the logic state of the input pin to be directly read by instructions. When the corresponding bit of the control register is written as a "0", the I/O pin will be setup as a CMOS output. If the pin is currently setup as an output, instructions can still be used to read the output register. However, it should be noted that the program will in fact only read the status of the output data latch and not the actual logic status of the output pin. Note that with the exception of the HT48F06E device, there is an additional configuration option for Port A that can select whether the inputs on this port are Schmitt Trigger types or non-Schmitt Trigger types. Inputs for the other ports are all Schmitt Trigger type.

Pin-shared Functions

The flexibility of the microcontroller range is greatly enhanced by the use of pins that have more than one function. Limited numbers of pins can force serious design constraints on designers but by supplying pins with multi-functions, many of these difficulties can be overcome. For some pins, the chosen function of the multi-function I/O pins is set by configuration options while for others the function is set by application program control.

- **Buzzer**

The buzzer pins BZ and \overline{BZ} are pin-shared with I/O pins PB0 and PB1. The buzzer function is selected via a configuration option and remains fixed after the device is programmed. Note that the corresponding bits of the port control register, PBC, must setup the pins as outputs to enable the buzzer outputs. If the PBC port control register has setup the pins as inputs, then the pins will function as normal logic inputs with the usual pull-high options, even if the buzzer configuration option has been selected.

- **External Interrupt Input**

The external interrupt pin \overline{INT} is pin-shared with the I/O pin PC0 or PG0 depending upon which device is used. For the shared function pins to operate as an external interrupt pin and not as a normal I/O pin, the corresponding external interrupt enable bits in the INTC interrupt control register must be correctly set. For applications not requiring an external interrupt input, the pin-shared external interrupt pin can be used as a normal I/O pin, however to do this, the external interrupt enable bits in the INTC register must be disabled.

- **External Timer/Event Counter Input**

Each device contains a single 8-bit Timer/Event Counter which has an external pin known as TMR. This is pin-shared with I/O pin PC0 or PC1. If this shared pin is to be used as a Timer/Event Counter input, then the Timer/Event Counter must be configured to be in the Event Counter or Pulse Width Measurement Mode. This is achieved by setting the appropriate bits in the relevant Timer/Event Counter Control Register. The pin must also be setup as an input by setting the appropriate bit in the Port Control Register. Pull-high resistor options can also be selected via the appropriate port pull-high configuration option. If the shared pin is to be used as a normal I/O pin, then the external timer input function must be disabled, by ensuring that the corresponding Timer/Event Counter is configured to be in the Off Mode or Timer Mode.

- **I/O Pin Structures**

The following diagrams illustrate the I/O pin internal structures. As the exact logical construction of the I/O pin may differ from these drawings, they are supplied as a guide only to assist with the functional understanding of the I/O pins. Note also that the specified pins refer to the largest device package, therefore not all pins specified will exist on all devices.

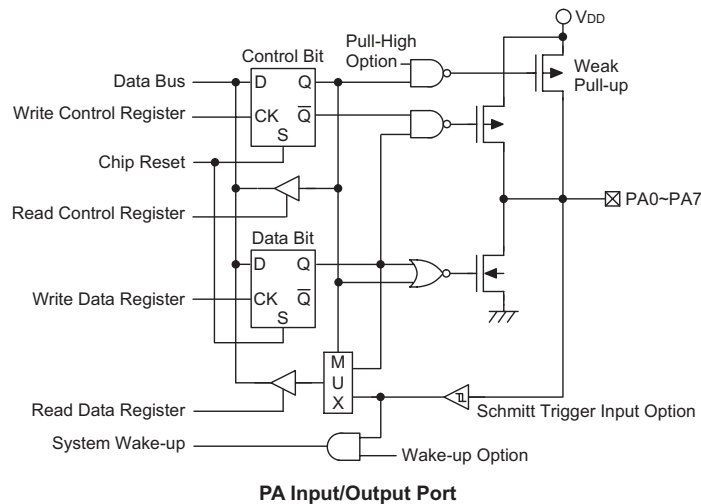

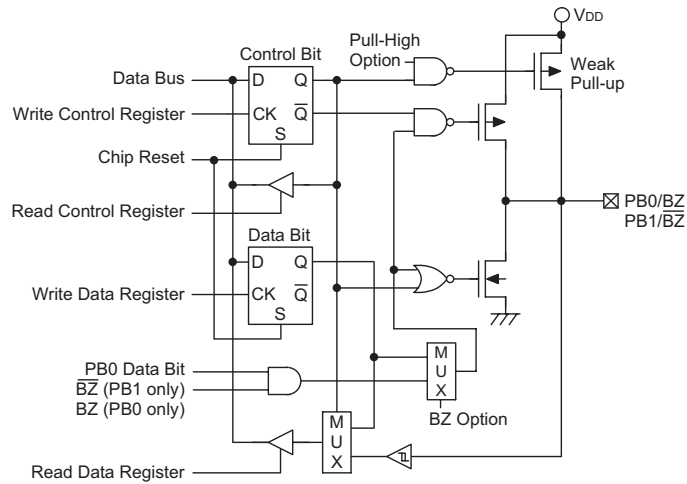

PB0~PB1 Input/Output Port

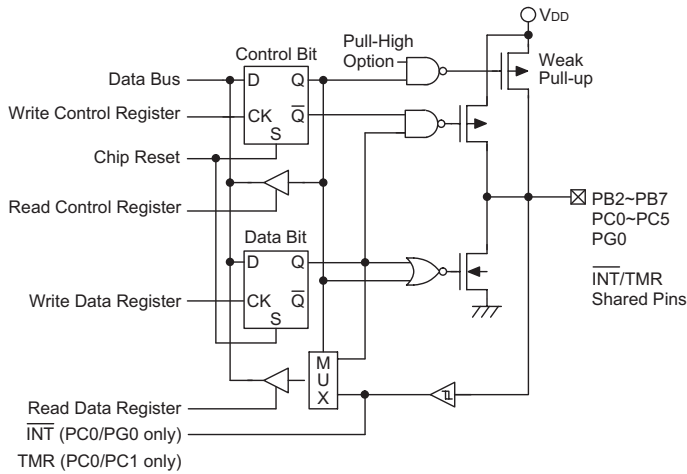

PB, PC and PG Input/Output Ports

Programming Considerations

Within the user program, one of the first things to consider is port initialization. After a reset, all of the I/O data and port control registers will be set high. This means that all I/O pins will default to an input state, the level of which depends on the other connected circuitry and whether pull-high options have been selected. If the port control registers, PAC, PBC, PCC, etc., are then programmed to setup some pins as outputs, these output pins will have an initial high output value unless the associated port data registers, PA, PB, PC, etc., are first programmed. Selecting which pins are inputs and which are outputs can be achieved byte-wide by loading the correct values into the appropriate port control register or by programming individual bits in the port control register using the "SET [m].i" and "CLR [m].i" instructions. Note that when using these bit control instructions, a read-modify-write operation takes place. The microcontroller must first read in the data on the entire port, modify it to the required new bit values and then rewrite this data back to the output ports.

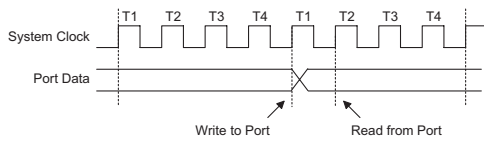

Read/Write Timing

Port A has the additional capability of providing wake-up functions. When the device is in the Power Down Mode, various methods are available to wake the device up. One of these is a high to low transition of any of the Port A pins. Single or multiple pins on Port A can be setup to have this function.

Timer/Event Counters

The provision of timers form an important part of any microcontroller, giving the designer a means of carrying out time related functions. Each device contains a single count-up timer of 8-bit capacity. As each timer has three

different operating modes, they can be configured to operate as a general timer, an external event counter or as a pulse width measurement device. The provision of an internal prescaler to the clock circuitry gives added range to the timer.

There are two types of registers related to the Timer/Event Counters. The first is the register that contains the actual value of the Timer/Event Counter and into which an initial value can be preloaded, and is known as TMR. Reading from this register retrieves the contents of the Timer/Event Counter. The second type of associated register is the Timer Control Register, which defines the timer options and determines how the Timer/Event Counter is to be used, and has the name TMRC. All devices can have the timer clock configured to come from the internal clock source. In addition, the timer clock source can also be configured to come from an external timer pin.

An external clock source is used when the Timer/Event Counter is in the event counting mode, the clock source being provided on the external timer pin. This pin has the name TMR and is pin-shared with an I/O pin. Depending upon the condition of the TE bit in the Timer Control Register, each high to low, or low to high transition on the external timer input pin will increment the Timer/Event Counter by one.

Configuring the Timer/Event Counter Input Clock Source

The Timer/Event Counter's clock can originate from various sources. The system clock source is used when the Timer/Event Counter is in the timer mode or in the pulse width measurement mode. The system clock is divided by a prescaler, the division ratio of which is conditioned by the Timer Control Register bits PSC2~PSC0.

An external clock source is used when the Timer/Event Counter is in the event counting mode, the clock source being provided on the external timer pin, TMR. Depending upon the condition of the TE bit, each high to low, or low to high transition on the external timer pin will increment the counter by one.

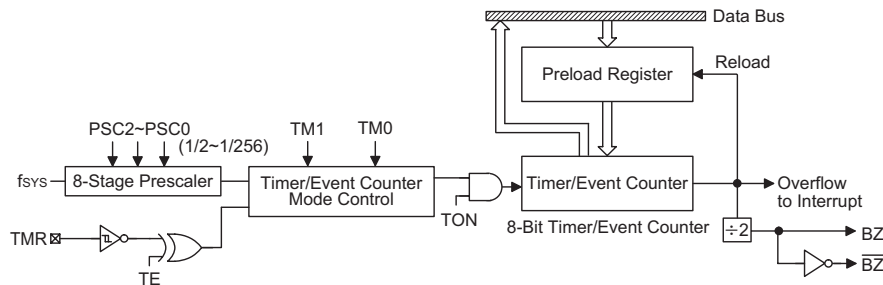

8-bit Timer/Event Counter Structure

Timer Register – TMR

The timer register is a special function register located in the Special Purpose RAM Data Memory and is the place where the actual timer value is stored. This register is known as TMR. The value in the timer register increases by one each time an internal clock pulse is received or an external transition occurs on the external timer pin. The timer will count from the initial value loaded by the preload register to the full count of FFH at which point the timer overflows and an internal interrupt signal is generated. The timer value will then be reset with the initial preload register value and continue counting.

To achieve a maximum full range count of FFH the preload register must first be cleared to all zeros. It should be noted that after power-on, the preload register will be in an unknown condition. Note that if the Timer/Event Counter is switched off and data is written to its preload register, this data will be immediately written into the actual timer register. However, if the Timer/Event Counter is enabled and counting, any new data written into the preload data register during this period will remain in the preload register and will only be written into the timer register the next time an overflow occurs.

Timer Control Register – TMRC

The flexible features of the Holtek microcontroller Timer/Event Counters enable them to operate in three

different modes, the options of which are determined by the contents of their control register, which has the name TMRC. It is the Timer Control Register together with its corresponding timer register that control the full operation of the Timer/Event Counter. Before the Timer/Event Counter can be used, it is essential that the Timer Control Register is fully programmed with the right data to ensure its correct operation, a process that is normally carried out during program initialisation.

To choose which of the three modes the Timer/Event Counter is to operate in, either in the timer mode, the event counting mode or the pulse width measurement mode, bits 7 and 6 of the Timer Control Register, which are known as the bit pair TM1/TM0, must be set to the required logic levels. The Timer/Event Counter on/off bit, which is bit 4 of the Timer Control Register and known as TON, provides the basic on/off control of the Timer/Event Counter. Setting the bit high allows the Timer/Event Counter to run, clearing the bit stops it running. Bits 0~2 of the Timer Control Register determine the division ratio of the input clock prescaler. The prescaler bit settings have no effect if an external clock source is used. If the Timer/Event Counter is in the event count or pulse width measurement mode, the active transition edge level type is selected by the logic level of bit 3 of the Timer Control Register which is known as TE.

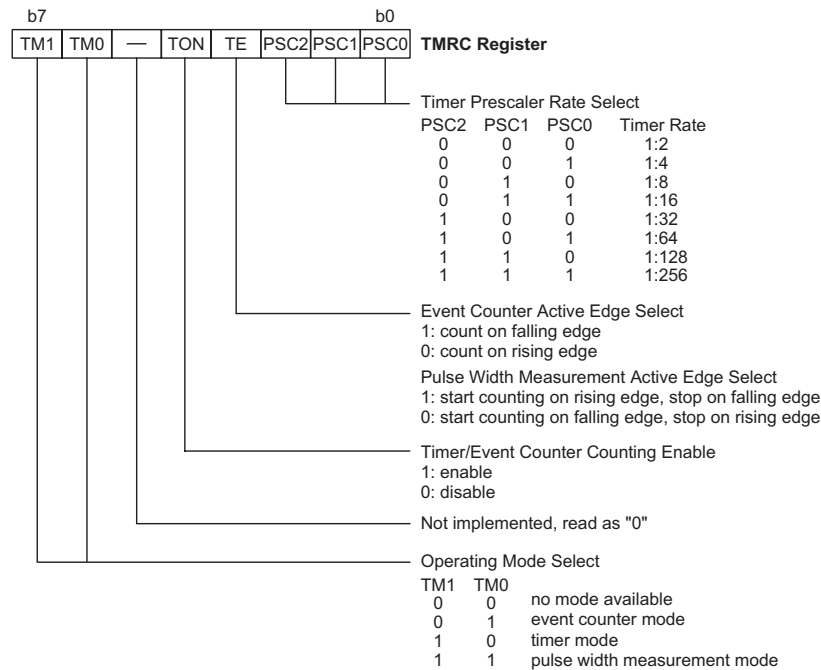

Timer/Event Counter Control Register

Configuring the Timer Mode

In this mode, the Timer/Event Counter can be utilised to measure fixed time intervals, providing an internal interrupt signal each time the Timer/Event Counter overflows. To operate in this mode, the Operating Mode Select bit pair in the Timer Control Register must be set to the correct value as shown.

Control Register Operating Mode Select Bits for the Timer Mode

Bit7	Bit6
1	0

In this mode the internal clock, f_{SYS} , is used as the Timer/Event Counter clock. However, this clock source is further divided by a prescaler, the value of which is determined by the Prescaler Rate Select bits, which are bits 0~2 in the Timer Control Register. After the other bits in the Timer Control Register have been setup, the enable bit, which is bit 4 of the Timer Control Register, can be set high to enable the Timer/Event Counter to run. Each time an internal clock cycle occurs, the Timer/Event Counter increments by one. When it is full and overflows, an interrupt signal is generated and the Timer/Event Counter will reload the value already loaded into the preload register and continue counting. The interrupt can be disabled by ensuring that the Timer/Event Counter Interrupt Enable bit in the Interrupt Control Register, INTC, is reset to zero.

Configuring the Event Counter Mode

In this mode, a number of externally changing logic events, occurring on the external timer pin, can be recorded by the Timer/Event Counter. To operate in this mode, the Operating Mode Select bit pair in the Timer Control Register must be set to the correct value as shown.

Control Register Operating Mode Select Bits for the Event Counter Mode

Bit7	Bit6
0	1

In this mode the external timer pin is used as the Timer/Event Counter clock source, however it is not di-

vided by the internal prescaler. After the other bits in the Timer Control Register have been setup, the enable bit, which is bit 4 of the Timer Control Register, can be set high to enable the Timer/Event Counter to run. If the Active Edge Select bit, which is bit 3 of the Timer Control Register, is low, the Timer/Event Counter will increment each time the external timer pin receives a low to high transition. If the Active Edge Select bit is high, the counter will increment each time the external timer pin receives a high to low transition. When it is full and overflows, an interrupt signal is generated and the Timer/Event Counter will reload the value already loaded into the preload register and continue counting. The interrupt can be disabled by ensuring that the Timer/Event Counter Interrupt Enable bit in the Interrupt Control Register, INTC, is reset to zero.

As the external timer pin is shared with an I/O pin, to ensure that the pin is configured to operate as an event counter input pin, two things have to happen. The first is to ensure that the Operating Mode Select bits in the Timer Control Register place the Timer/Event Counter in the Event Counting Mode, the second is to ensure that the port control register configures the pin as an input. It should be noted that in the event counting mode, even if the microcontroller is in the Power Down Mode, the Timer/Event Counter will continue to record externally changing logic events on the timer input pin. As a result when the timer overflows it will generate a timer interrupt and corresponding wake-up source.

Configuring the Pulse Width Measurement Mode

In this mode, the Timer/Event Counter can be utilised to measure the width of external pulses applied to the external timer pin. To operate in this mode, the Operating Mode Select bit pair in the Timer Control Register must be set to the correct value as shown.

Control Register Operating Mode Select Bits for the Pulse Width Measurement Mode

Bit7	Bit6
1	1

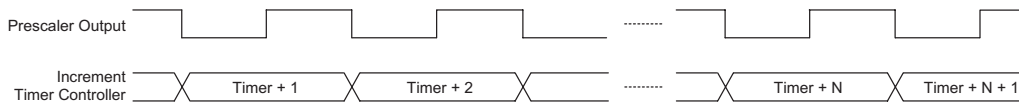

Timer Mode Timing Diagram

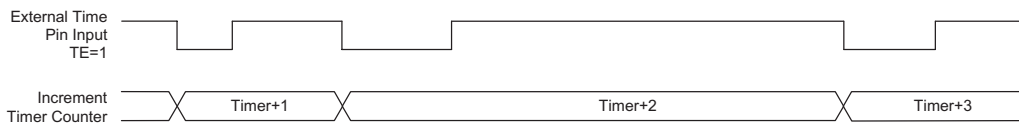

Event Counter Mode Timing Diagram

In this mode the internal clock, f_{SYS} , is used as the Timer/Event Counter clock. However, this clock source is further divided by a prescaler, the value of which is determined by the Prescaler Rate Select bits, which are bits 0~2 in the Timer Control Register. After the other bits in the Timer Control Register have been setup, the enable bit, which is bit 4 of the Timer Control Register, can be set high to enable the Timer/Event Counter, however it will not actually start counting until an active edge is received on the external timer pin.

If the Active Edge Select bit, which is bit 3 of the Timer Control Register, is low, once a high to low transition has been received on the external timer pin, the Timer/Event Counter will start counting until the external timer pin returns to its original high level. At this point the enable bit will be automatically reset to zero and the Timer/Event Counter will stop counting. If the Active Edge Select bit is high, the Timer/Event Counter will begin counting once a low to high transition has been received on the external timer pin and stop counting when the external timer pin returns to its original low level. As before, the enable bit will be automatically reset to zero and the Timer/Event Counter will stop counting. It is important to note that in the Pulse Width Measurement Mode, the enable bit is automatically reset to zero when the external control signal on the external timer pin returns to its original level, whereas in the other two modes the enable bit can only be reset to zero under program control.

The residual value in the Timer/Event Counter, which can now be read by the program, therefore represents the length of the pulse received on the external timer pin. As the enable bit has now been reset, any further transitions on the external timer pin will be ignored. Not until the enable bit is again set high by the program can the timer begin further pulse width measurements. In this way, single shot pulse measurements can be easily made.

It should be noted that in this mode the Timer/Event Counter is controlled by logical transitions on the external timer pin and not by the logic level. When the Timer/Event Counter is full and overflows, an interrupt signal is generated and the Timer/Event Counter will reload the value already loaded into the preload register and continue counting. The interrupt can be disabled by ensuring that the Timer/Event Counter Interrupt Enable

bit in the Interrupt Control Register, INTC, is reset to zero.

As the external timer pin is shared with an I/O pin, to ensure that the pin is configured to operate as a pulse width measurement pin, two things have to happen. The first is to ensure that the Operating Mode Select bits in the Timer Control Register place the Timer/Event Counter in the Pulse Width Measurement Mode, the second is to ensure that the port control register configures the pin as an input.

Programmable Frequency Divider (PFD) and Buzzer Application

Operating similar to a programmable frequency divider, the buzzer function within the microcontroller provides a means of producing a variable frequency output suitable for applications, such as piezo-buzzer driving or other interfaces requiring a precise frequency generator.

The BZ and \overline{BZ} are a complimentary pair and pin-shared with I/O pins, PB0 and PB1. The function is selected via configuration option, however, if not selected, the pins can operate as normal I/O pins. Note that the \overline{BZ} pin is the inverse of the BZ pin generating a kind of differential output and supplying more power to connected interfaces such as buzzers. Note that the 16-pin NSOP package type only has a single BZ output as pin PB1/ \overline{BZ} does not exist on this package.

The timer overflow signal is the clock source for the buzzer circuit. The output frequency is controlled by loading the required values into the timer prescaler and timer registers to give the required division ratio. The counter will begin to count-up from this preload register value until full, at which point an overflow signal is generated, causing both the BZ and \overline{BZ} outputs to change state. The counter will then be automatically reloaded with the preload register value and continue counting-up.

If the configuration option has selected the buzzer function, then for both buzzer outputs to operate, it is essential that the Port B control register PBC bit 0 and PBC bit 1 are setup as outputs. If only one pin is setup as an output, the other pin can still be used as a normal data input pin. However, if both pins are setup as inputs then the buzzer will not function. The buzzer outputs will only be

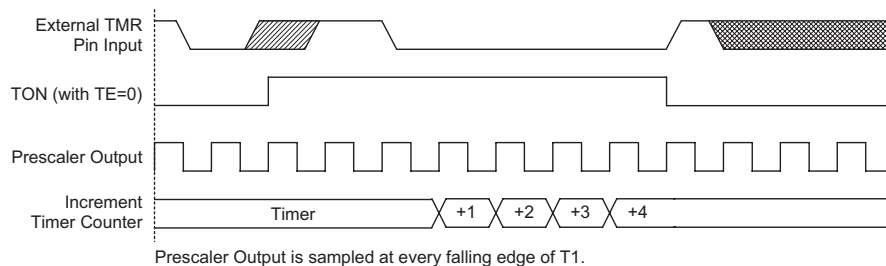

Pulse Width Measure Mode Timing Diagram

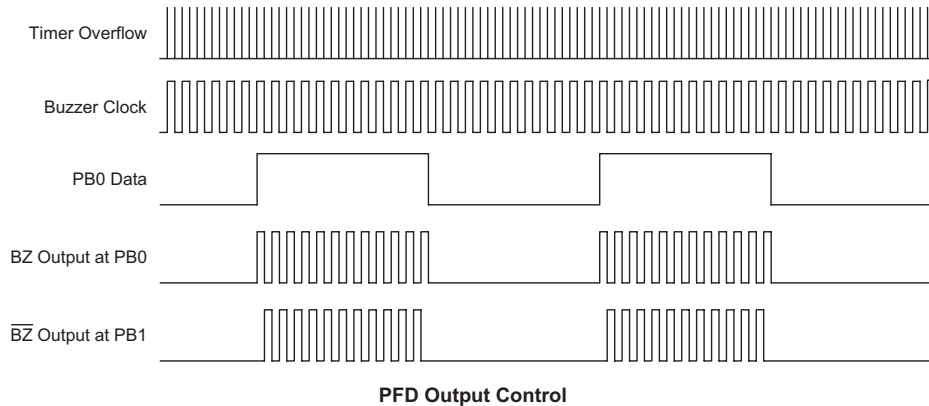

PFD Output Control

activated if bit PB0 is set to "1". This output data bit is used as the on/off control bit for the buzzer outputs. Note that the BZ and $\overline{\text{BZ}}$ outputs will both be low if the PB0 output data bit is cleared to "0". The condition of data bit PB1 has no effect on the overall control of the BZ and $\overline{\text{BZ}}$ pins.

Using this method of frequency generation, and if a crystal oscillator is used for the system clock, very precise values of frequency can be generated.

Prescaler

The single 8-bit timer in the devices all possess a prescaler. Bits 0~2 of the Timer Control Register, define the prescaling stages of the internal clock source of the Timer/Event Counter.

I/O Interfacing

The Timer/Event Counter, when configured to run in the event counter or pulse width measurement mode, requires the use of an external pin for correct operation. As the external timer pin is pin-shared with an I/O pin, it must be configured correctly to ensure it is setup for use as a Timer/Event Counter input and not as a normal I/O pin. This is implemented by ensuring that the mode select bits in the Timer/Event Counter control register, select either the event counter or pulse width measurement mode. Additionally the Port Control Register bit for this pin must be set high to ensure that the pin is setup as an input. Any pull high configuration for this pins will remain valid even if the pin is used as a Timer/Event Counter input.

Programming Considerations

When configured to run in the timer mode, the internal system clock is used as the timer clock source and is therefore synchronized with the overall operation of the microcontroller. In this mode, when the appropriate timer register is full, the microcontroller will generate an

internal interrupt signal directing the program flow to the respective internal interrupt vector. For the pulse width measurement mode, the internal system clock is also used as the timer clock source but the timer will only run when the correct logic condition appears on the external timer input pin. As this is an external event and not synchronised with the internal timer clock, the microcontroller will only see this external event when the next timer clock pulse arrives. As a result there may be small differences in measured values requiring programmers to take this into account during programming. The same applies if the timer is configured to be in the event counting mode which again is an external event and not synchronised with the internal system or timer clock.

When the Timer/Event Counter is read or if data is written to the preload registers, the clock is inhibited to avoid errors, however as this may result in a counting error, this should be taken into account by the programmer. Care must be taken to ensure that the timers are properly initialised before using them for the first time. The associated timer enable bits in the interrupt control register must be properly set otherwise the internal interrupt associated with the timer will remain inactive. The edge select, timer mode and clock source control bits in timer control register must also be correctly set to ensure the timer is properly configured for the required application. It is also important to ensure that an initial value is first loaded into the timer register before the timer is switched on; this is because after power-on the initial value of the timer register is unknown. After the timer has been initialised the timer can be turned on and off by controlling the enable bit in the timer control register. Note that setting the timer enable bit high to turn the timer on, should only be executed after the timer mode bits have been properly setup. Setting the timer enable bit high together with a mode bit modification, may lead to improper timer operation if executed as a single timer control register byte write instruction.

When the Timer/Event counter overflows, its corresponding interrupt request flag in the interrupt control register will be set. If the timer interrupt is enabled this will in turn generate an interrupt signal. However irrespective of whether the timer interrupt is enabled or not, a Timer/Event counter overflow will also generate a wake-up signal if the device is in a Power-down condition. This situation may occur if the Timer/Event Counter is in the Event Counting Mode and if the external signal continues to change state. In such a case, the Timer/Event Counter will continue to count these external events and if an overflow occurs the device will be woken up from its Power-down condition. To prevent such a wake-up from occurring, the timer interrupt re-

quest flag should first be set high before issuing the HALT instruction to enter the Power Down Mode.

Timer Program Example

This program example shows how the Timer/Event Counter registers are setup, along with how the interrupts are enabled and managed. Note how the Timer/Event Counter is turned on, by setting bit 4 of the Timer Control Register. The Timer/Event Counter can be turned off in a similar way by clearing the same bit. This example program sets the Timer/Event Counter to be in the timer mode, which uses the internal system clock as the clock source.

```

org 04h          ; external interrupt vector
reti
org 08h          ; Timer/Event Counter interrupt vector
jmp tmrint      ; jump here when Timer overflows
:
org 20h          ; main program
;internal Timer/Event Counter interrupt routine
tmrint:
:
; Timer/Event Counter main program placed here
:
reti
:
:
begin:
;setup Timer registers
mov a,09bh      ; setup preload value - timer counts from this value to FFH
mov tmr,a;
mov a,081h      ; setup Timer control register
mov tmrc,a     ; timer mode and prescaler set to /4
; setup interrupt register
mov a,005h      ; enable master interrupt and timer interrupt
mov intc,a
set tmrc.4     ; start Timer - note mode bits must be previously setup

```

Interrupts

Interrupts are an important part of any microcontroller system. When an external event or an internal function such as a Timer/Event Counter requires microcontroller attention, their corresponding interrupt will enforce a temporary suspension of the main program allowing the microcontroller to direct attention to their respective needs. Each device contains a single external interrupt and single internal timer interrupt functions. The external interrupt is controlled by the action of the external \overline{INT} pin, while the internal interrupt is controlled by the Timer/Event Counter overflow.

Interrupt Register

Overall interrupt control, which means interrupt enabling and request flag setting, is controlled by a single INTC register, which is located in the RAM Data Memory. By controlling the appropriate enable bits in this register each individual interrupt can be enabled or disabled. Also when an interrupt occurs, the corresponding request flag will be set by the microcontroller. The global enable flag if cleared to zero will disable all interrupts.

Interrupt Operation

A Timer/Event Counter overflow or the external interrupt line being pulled low will all generate an interrupt request by setting their corresponding request flag, if their appropriate interrupt enable bit is set. When this happens, the Program Counter, which stores the address of the next instruction to be executed, will be transferred onto the stack. The Program Counter will then be loaded

with a new address which will be the value of the corresponding interrupt vector. The microcontroller will then fetch its next instruction from this interrupt vector. The instruction at this vector will usually be a JMP statement which will take program execution to another section of program which is known as the interrupt service routine. Here is located the code to control the appropriate interrupt. The interrupt service routine must be terminated with a RETI statement, which retrieves the original Program Counter address from the stack and allows the microcontroller to continue with normal execution at the point where the interrupt occurred.

The various interrupt enable bits, together with their associated request flags, are shown in the following diagram with their order of priority.

Once an interrupt subroutine is serviced, all the other interrupts will be blocked, as the EMI bit will be cleared automatically. This will prevent any further interrupt nesting from occurring. However, if other interrupt requests occur during this interval, although the interrupt will not be immediately serviced, the request flag will still be recorded. If an interrupt requires immediate servicing while the program is already in another interrupt service routine, the EMI bit should be set after entering the routine, to allow interrupt nesting. If the stack is full, the interrupt request will not be acknowledged, even if the related interrupt is enabled, until the Stack Pointer is decremented. If immediate service is desired, the stack must be prevented from becoming full.

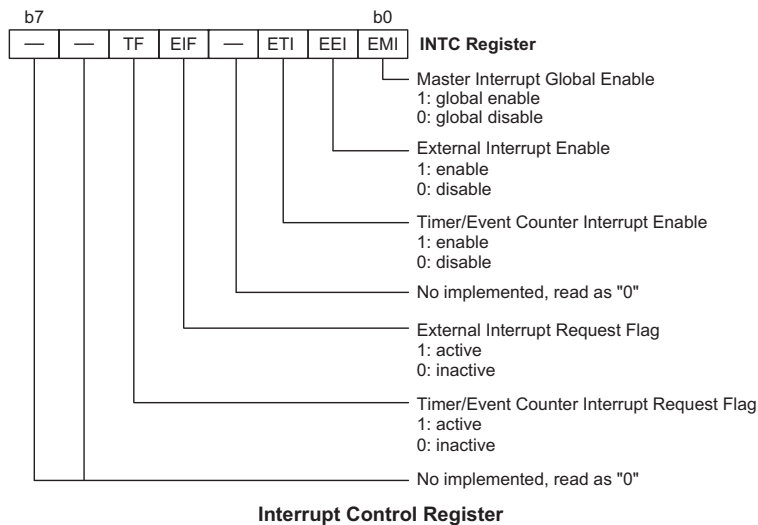

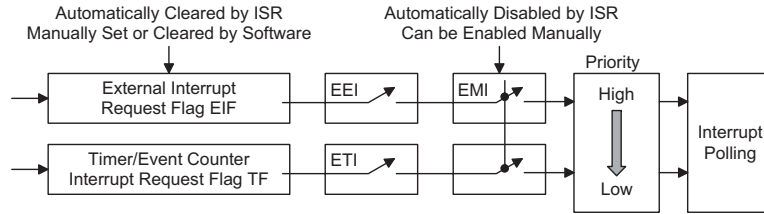

Interrupt Structure

Interrupt Priority

Interrupts, occurring in the interval between the rising edges of two consecutive T2 pulses, will be serviced on the latter of the two T2 pulses, if the corresponding interrupts are enabled. In case of simultaneous requests, the following table shows the priority that is applied. These can be masked by resetting the EMI bit.

Interrupt Source	All Devices Priority
External Interrupt	1
Timer/Event Counter Overflow	2

In cases where both external and internal interrupts are enabled and where an external and internal interrupt occurs simultaneously, the external interrupt will always have priority and will therefore be serviced first. Suitable masking of the individual interrupts using the INTC register can prevent simultaneous occurrences.

External Interrupt

For an external interrupt to occur, the global interrupt enable bit, EMI, and external interrupt enable bit, EEl, must first be set. An actual external interrupt will take place when the external interrupt request flag, EIF, is set, a situation that will occur when a high to low transition appears on the \overline{INT} line. The external interrupt pin is pin-shared with an I/O pin PC.0 or PG.0 and can only be configured as an external interrupt pin if the corresponding external interrupt enable bit in the INTC register has been set. The pin must also be setup as an input by setting the corresponding PCC.0 or PGC.0 bit in the port control register. When the interrupt is enabled, the stack is not full and a high to low transition appears on the external interrupt pin, a subroutine call to the external interrupt vector at location 04H, will take place. When the interrupt is serviced, the external interrupt request flag, EIF, will be automatically reset and the EMI bit will be automatically cleared to disable other interrupts. Note that any pull-high resistor configuration options on this pin will remain valid even if the pin is used as an external interrupt input.

Timer/Event Counter Interrupt

For a Timer/Event Counter interrupt to occur, the global interrupt enable bit, EMI, and the corresponding timer interrupt enable bit, ETI, must first be set. An actual Timer/Event Counter interrupt will take place when the Timer/Event Counter request flag, TF, is set, a situation that will occur when the Timer/Event Counter overflows. When the interrupt is enabled, the stack is not full and a Timer/Event Counter overflow occurs, a subroutine call to the timer interrupt vector at location 08H, will take place. When the interrupt is serviced, the timer interrupt request flag, TF, will be automatically reset and the EMI bit will be automatically cleared to disable other interrupts.

Programming Considerations

By disabling the interrupt enable bits, a requested interrupt can be prevented from being serviced, however, once an interrupt request flag is set, it will remain in this condition in the INTC register until the corresponding interrupt is serviced or until the request flag is cleared by a software instruction.

It is recommended that programs do not use the "CALL subroutine" instruction within the interrupt subroutine. Interrupts often occur in an unpredictable manner or need to be serviced immediately in some applications. If only one stack is left and the interrupt is not well controlled, the original control sequence will be damaged once a "CALL subroutine" is executed in the interrupt subroutine.

All of these interrupts have the capability of waking up the processor when in the Power Down Mode. Only the Program Counter is pushed onto the stack. If the contents of the register or status register are altered by the interrupt service program, which may corrupt the desired control sequence, then the contents should be saved in advance.

Reset and Initialisation

A reset function is a fundamental part of any microcontroller ensuring that the device can be set to some predetermined condition irrespective of outside parameters. The most important reset condition is after power is first applied to the microcontroller. In this case, internal circuitry will ensure that the microcontroller, after a short delay, will be in a well defined state and ready to execute the first program instruction. After this power-on reset, certain important internal registers will be set to defined states before the program commences. One of these registers is the Program Counter, which will be reset to zero forcing the microcontroller to begin program execution from the lowest Program Memory address.

In addition to the power-on reset, situations may arise where it is necessary to forcefully apply a reset condition when the microcontroller is running. One example of this is where after power has been applied and the microcontroller is already running, the $\overline{\text{RES}}$ line is forcefully pulled low. In such a case, known as a normal operation reset, some of the microcontroller registers remain unchanged allowing the microcontroller to proceed with normal operation after the reset line is allowed to return high. Another type of reset is when the Watchdog Timer overflows and resets the microcontroller. All types of reset operations result in different register conditions being setup.

Another reset exists in the form of a Low Voltage Reset, LVR, where a full reset, similar to the $\overline{\text{RES}}$ reset is implemented in situations where the power supply voltage falls below a certain threshold.

Reset Functions

There are five ways in which a microcontroller reset can occur, through events occurring both internally and externally:

- Power-on Reset

The most fundamental and unavoidable reset is the one that occurs after power is first applied to the microcontroller. As well as ensuring that the Program Memory begins execution from the first memory address, a power-on reset also ensures that certain other registers are preset to known conditions. All the I/O port and port control registers will power up in a high condition ensuring that all pins will be first set to inputs.

Although the microcontroller has an internal RC reset function, if the VDD power supply rise time is not fast enough or does not stabilise quickly at power-on, the internal reset function may be incapable of providing proper reset operation. For this reason it is recommended that an external RC network is connected to the $\overline{\text{RES}}$ pin, whose additional time delay will ensure that the $\overline{\text{RES}}$ pin remains low for an extended period to allow the power supply to stabilise. During this time delay, normal operation of the microcontroller will be

inhibited. After the $\overline{\text{RES}}$ line reaches a certain voltage value, the reset delay time t_{RSTD} is invoked to provide an extra delay time after which the microcontroller will begin normal operation. The abbreviation SST in the figures stands for System Start-up Timer.

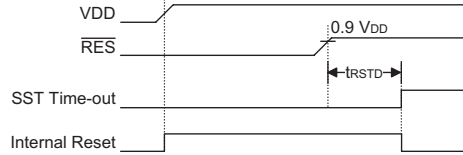

Power-On Reset Timing Chart

For most applications a resistor connected between VDD and the $\overline{\text{RES}}$ pin and a capacitor connected between VSS and the $\overline{\text{RES}}$ pin will provide a suitable external reset circuit. Any wiring connected to the $\overline{\text{RES}}$ pin should be kept as short as possible to minimise any stray noise interference.

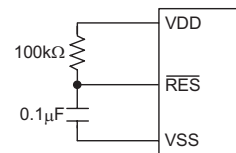

Basic Reset Circuit

For applications that operate within an environment where more noise is present the Enhanced Reset Circuit shown is recommended.

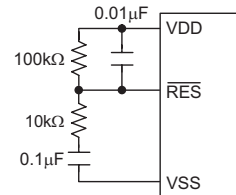

Enhanced Reset Circuit

More information regarding external reset circuits is located in Application Note HA0075E on the Holtek website.

- $\overline{\text{RES}}$ Pin Reset

This type of reset occurs when the microcontroller is already running and the $\overline{\text{RES}}$ pin is forcefully pulled low by external hardware such as an external switch. In this case as in the case of other reset, the Program Counter will reset to zero and program execution initiated from this point.

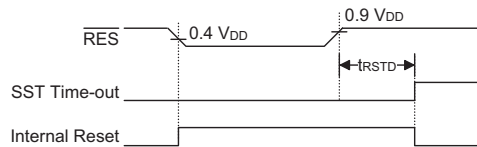

$\overline{\text{RES}}$ Reset Timing Chart

• **Low Voltage Reset – LVR**

The microcontroller contains a low voltage reset circuit in order to monitor the supply voltage of the device, which is selected via a configuration option. If the supply voltage of the device drops to within a range of $0.9V \sim V_{LVR}$ such as might occur when changing the battery, the LVR will automatically reset the device internally. The LVR includes the following specifications: For a valid LVR signal, a low voltage, i.e., a voltage in the range between $0.9V \sim V_{LVR}$ must exist for greater than the value t_{LVR} specified in the A.C. characteristics. If the low voltage state does not exceed 1ms, the LVR will ignore it and will not perform a reset function.

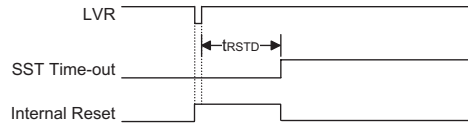

Low Voltage Reset Timing Chart

- **Watchdog Time-out Reset during Normal Operation**
The Watchdog time-out Reset during normal operation is the same as a hardware RES pin reset except that the Watchdog time-out flag TO will be set to "1".

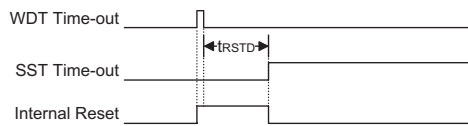

WDT Time-out Reset during Normal Operation Timing Chart

- **Watchdog Time-out Reset during Power Down**
The Watchdog time-out Reset during Power Down is a little different from other kinds of reset. Most of the conditions remain unchanged except that the Program Counter and the Stack Pointer will be cleared to "0" and the TO flag will be set to "1". Refer to the A.C. Characteristics for t_{SST} details.

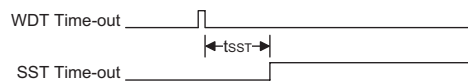

WDT Time-out Reset during Power Down Timing Chart

Reset Initial Conditions

The different types of reset described affect the reset flags in different ways. These flags, known as PDF and TO are located in the status register and are controlled by various microcontroller operations, such as the Power Down function or Watchdog Timer. The reset flags are shown in the table:

TO	PDF	RESET Conditions
0	0	RES reset during power-on
u	u	RES or LVR reset during normal operation
1	u	WDT time-out reset during normal operation
1	1	WDT time-out reset during Power Down

Note: "u" stands for unchanged

The following table indicates the way in which the various components of the microcontroller are affected after a power-on reset occurs.

Item	Condition After RESET
Program Counter	Reset to zero
Interrupts	All interrupts will be disabled
WDT	Clear after reset, WDT begins counting
Timer/Event Counter	Timer Counter will be turned off
Prescaler	The Timer Counter Prescaler will be cleared
Input/Output Ports	I/O ports will be setup as inputs
Stack Pointer	Stack Pointer will point to the top of the stack

The different kinds of resets all affect the internal registers of the microcontroller in different ways. To ensure reliable continuation of normal program execution after a reset occurs, it is important to know what condition the microcontroller is in after a particular reset occurs. The following table describes how each type of reset affects each of the microcontroller internal registers. Note that where more than one package type exists the table will reflect the situation for the larger package type.

HT48F06E and HT48F10E

Register	Reset (Power-on)	$\overline{\text{RES}}$ or LVR Reset	WDT Time-out (Normal Operation)	WDT Time-out (HALT)
MP0	1 x x x x x x x	1 u u u u u u u	1 u u u u u u u	1 u u u u u u u
MP1	1 x x x x x x x	1 u u u u u u u	1 u u u u u u u	1 u u u u u u u
BP	0 0 0 0 0 0 0 0	0 0 0 0 0 0 0 0	0 0 0 0 0 0 0 0	u u u u u u u u
ACC	x x x x x x x x	u u u u u u u u	u u u u u u u u	u u u u u u u u
PCL	0 0 0 0 0 0 0 0	0 0 0 0 0 0 0 0	0 0 0 0 0 0 0 0	0 0 0 0 0 0 0 0
TBLP	x x x x x x x x	u u u u u u u u	u u u u u u u u	u u u u u u u u
TBLH	-- x x x x x x	-- u u u u u u	-- u u u u u u	-- u u u u u u
WDTS	0 0 0 0 0 1 1 1	0 0 0 0 0 1 1 1	0 0 0 0 0 1 1 1	u u u u u u u u
STATUS	-- 0 0 x x x x	-- u u u u u u	-- 1 u u u u u	-- 1 1 u u u u
INTC	-- 0 0 - 0 0 0	-- 0 0 - 0 0 0	-- 0 0 - 0 0 0	-- u u - u u u
TMR	x x x x x x x x	x x x x x x x x	x x x x x x x x	u u u u u u u u
TMRC	0 0 - 0 1 0 0 0	0 0 - 0 1 0 0 0	0 0 - 0 1 0 0 0	u u - u u u u u
PA	1 1 1 1 1 1 1 1	1 1 1 1 1 1 1 1	1 1 1 1 1 1 1 1	u u u u u u u u
PAC	1 1 1 1 1 1 1 1	1 1 1 1 1 1 1 1	1 1 1 1 1 1 1 1	u u u u u u u u
PB	1 1 1 1 1 1 1 1	1 1 1 1 1 1 1 1	1 1 1 1 1 1 1 1	u u u u u u u u
PBC	1 1 1 1 1 1 1 1	1 1 1 1 1 1 1 1	1 1 1 1 1 1 1 1	u u u u u u u u
PC	---- - 1 1 1	---- - 1 1 1	---- - 1 1 1	---- - u u u
PCC	---- - 1 1 1	---- - 1 1 1	---- - 1 1 1	---- - u u u
EECR	1 0 0 0 ----	1 0 0 0 ----	1 0 0 0 ----	u u u u ----

Note: "u" stands for unchanged
"x" stands for unknown
"--" stands for unimplemented

HT48F30E

Register	Reset (Power-on)	$\overline{\text{RES}}$ or LVR Reset	WDT Time-out (Normal Operation)	WDT Time-out (HALT)
MP0	1 x x x x x x x	1 u u u u u u u	1 u u u u u u u	1 u u u u u u u
MP1	1 x x x x x x x	1 u u u u u u u	1 u u u u u u u	1 u u u u u u u
BP	0 0 0 0 0 0 0 0	0 0 0 0 0 0 0 0	0 0 0 0 0 0 0 0	u u u u u u u u
ACC	x x x x x x x x	u u u u u u u u	u u u u u u u u	u u u u u u u u
PCL	0 0 0 0 0 0 0 0	0 0 0 0 0 0 0 0	0 0 0 0 0 0 0 0	0 0 0 0 0 0 0 0
TBLP	x x x x x x x x	u u u u u u u u	u u u u u u u u	u u u u u u u u
TBLH	-- x x x x x x	-- u u u u u u	-- u u u u u u	-- u u u u u u
WDTS	0 0 0 0 0 1 1 1	0 0 0 0 0 1 1 1	0 0 0 0 0 1 1 1	u u u u u u u u
STATUS	-- 0 0 x x x x	-- u u u u u u	-- 1 u u u u u	-- 1 1 u u u u
INTC	-- 0 0 - 0 0 0	-- 0 0 - 0 0 0	-- 0 0 - 0 0 0	-- u u - u u u
TMR	x x x x x x x x	x x x x x x x x	x x x x x x x x	u u u u u u u u
TMRC	0 0 - 0 1 0 0 0	0 0 - 0 1 0 0 0	0 0 - 0 1 0 0 0	u u - u u u u u
PA	1 1 1 1 1 1 1 1	1 1 1 1 1 1 1 1	1 1 1 1 1 1 1 1	u u u u u u u u
PAC	1 1 1 1 1 1 1 1	1 1 1 1 1 1 1 1	1 1 1 1 1 1 1 1	u u u u u u u u
PB	1 1 1 1 1 1 1 1	1 1 1 1 1 1 1 1	1 1 1 1 1 1 1 1	u u u u u u u u
PBC	1 1 1 1 1 1 1 1	1 1 1 1 1 1 1 1	1 1 1 1 1 1 1 1	u u u u u u u u
PC	-- 1 1 1 1 1 1	-- 1 1 1 1 1 1	-- 1 1 1 1 1 1	-- u u u u u u
PCC	-- 1 1 1 1 1 1	-- 1 1 1 1 1 1	-- 1 1 1 1 1 1	-- u u u u u u
PG	---- - - - 1	---- - - - 1	---- - - - 1	---- - - - u
PGC	---- - - - 1	---- - - - 1	---- - - - 1	---- - - - u
EECR	1 0 0 0 - - - -	1 0 0 0 - - - -	1 0 0 0 - - - -	u u u u - - - -

Note: "u" stands for unchanged
"x" stands for unknown
"--" stands for unimplemented

Oscillator

Various oscillator options offer the user a wide range of functions according to their various application requirements. Two types of system clocks can be selected while various clock source options for the Watchdog Timer are provided for maximum flexibility. All oscillator options are selected through the configuration options.

The two methods of generating the system clock are:

- External crystal/resonator oscillator
- External RC oscillator

One of these two methods must be selected using the configuration options.

More information regarding the oscillator is located in Application Note HA0075E on the Holtek website.

External Crystal/Resonator Oscillator

The simple connection of a crystal across OSC1 and OSC2 will create the necessary phase shift and feedback for oscillation, and will normally not require external capacitors. However, for some crystals and most resonator types, to ensure oscillation and accurate frequency generation, it may be necessary to add two small value external capacitors, C1 and C2. The exact values of C1 and C2 should be selected in consultation

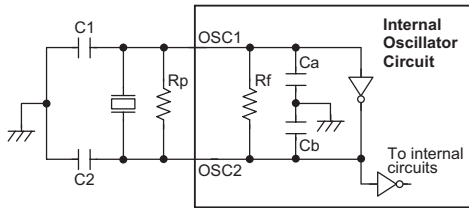

- Note: 1. Rp is normally not required.
2. Although not shown OSC1/OSC2 pins have a parasitic capacitance of around 7pF.

Crystal/Resonator Oscillator

with the crystal or resonator manufacturer's specification. The external parallel feedback resistor, Rp, is normally not required but in some cases may be needed to assist with oscillation start up.

Internal Ca, Cb, Rf Typical Values @ 5V, 25°C		
Ca	Cb	Rf
8pF	10pF	800kΩ

Oscillator Internal Component Values

Crystal Oscillator C1 and C2 Values			
Crystal Frequency	C1	C2	CL
12MHz	TBD	TBD	TBD
8MHz	TBD	TBD	TBD
4MHz	TBD	TBD	TBD
1MHz	TBD	TBD	TBD

Note: 1. C1 and C2 values are for guidance only.
2. CL is the crystal manufacturer specified load capacitor value.

Crystal Recommended Capacitor Values

Resonator C1 and C2 Values		
Resonator Frequency	C1	C2
3.58MHz	TBD	TBD
1MHz	TBD	TBD
455kHz	TBD	TBD

Note: C1 and C2 values are for guidance only.

Resonator Recommended Capacitor Values

External RC Oscillator

Using the external system RC oscillator requires that a resistor, with a value between 24kΩ and 1MΩ, is connected between OSC1 and VDD, and a capacitor is connected to ground. The generated system clock divided by 4 will be provided on OSC2 as an output which can be used for external synchronization purposes. Note that as the OSC2 output is an NMOS open-drain type, a pull high resistor should be connected if it to be used to monitor the internal frequency. Although this is a cost effective oscillator configuration, the oscillation frequency can vary with VDD, temperature and process variations and is therefore not suitable for applications where timing is critical or where accurate oscillator frequencies are required. For the value of the external resistor R_{osc} refer to the Holtek website for typical RC Oscillator vs. Temperature and VDD characteristics graphics. Note that it is the only microcontroller internal circuitry together with the external resistor, that determine the frequency of the oscillator. The external capacitor shown on the diagram does not influence the frequency of oscillation.

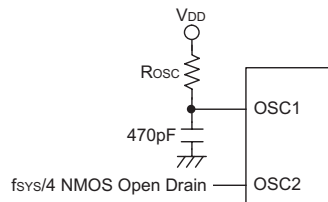

External RC Oscillator

Watchdog Timer Oscillator

The WDT oscillator is a fully self-contained free running on-chip RC oscillator with a typical period of 65 μ s at 5V requiring no external components. When the device enters the Power Down Mode, the system clock will stop running but the WDT oscillator continues to free-run and to keep the watchdog active. However, to preserve power in certain applications the WDT oscillator can be disabled via a configuration option.

Power Down Mode and Wake-up

Power Down Mode

All of the Holtek microcontrollers have the ability to enter a Power Down Mode, also known as the HALT Mode or Sleep Mode. When the device enters this mode, the normal operating current, will be reduced to an extremely low standby current level. This occurs because when the device enters the Power Down Mode, the system oscillator is stopped which reduces the power consumption to extremely low levels, however, as the device maintains its present internal condition, it can be woken up at a later stage and continue running, without requiring a full reset. This feature is extremely important in application areas where the MCU must have its power supply constantly maintained to keep the device in a known condition but where the power supply capacity is limited such as in battery applications.

Entering the Power Down Mode

There is only one way for the device to enter the Power Down Mode and that is to execute the "HALT" instruction in the application program. When this instruction is executed, the following will occur:

- The system oscillator will stop running and the application program will stop at the "HALT" instruction.
- The Data Memory contents and registers will maintain their present condition.
- The WDT will be cleared and resume counting if the WDT clock source is selected to come from the WDT oscillator. The WDT will stop if its clock source originates from the system clock.
- The I/O ports will maintain their present condition.
- In the status register, the Power Down flag, PDF, will be set and the Watchdog time-out flag, TO, will be cleared.

Standby Current Considerations

As the main reason for entering the Power Down Mode is to keep the current consumption of the MCU to as low a value as possible, perhaps only in the order of several micro-amps, there are other considerations which must also be taken into account by the circuit designer if the power consumption is to be minimized. Special atten-

tion must be made to the I/O pins on the device. All high-impedance input pins must be connected to either a fixed high or low level as any floating input pins could create internal oscillations and result in increased current consumption. Care must also be taken with the loads, which are connected to I/Os, which are setup as outputs. These should be placed in a condition in which minimum current is drawn or connected only to external circuits that do not draw current, such as other CMOS inputs. Also note that additional standby current will also be required if the configuration options have enabled the Watchdog Timer internal oscillator.

Wake-up

After the system enters the Power Down Mode, it can be woken up from one of various sources listed as follows:

- An external reset
- An external falling edge on Port A
- A system interrupt
- A WDT overflow

If the system is woken up by an external reset, the device will experience a full system reset, however, if the device is woken up by a WDT overflow, a Watchdog Timer reset will be initiated. Although both of these wake-up methods will initiate a reset operation, the actual source of the wake-up can be determined by examining the TO and PDF flags. The PDF flag is cleared by a system power-up or executing the clear Watchdog Timer instructions and is set when executing the "HALT" instruction. The TO flag is set if a WDT time-out occurs, and causes a wake-up that only resets the Program Counter and Stack Pointer, the other flags remain in their original status.

Each pin on Port A can be setup via an individual configuration option to permit a negative transition on the pin to wake-up the system. When a Port A pin wake-up occurs, the program will resume execution at the instruction following the "HALT" instruction.

If the system is woken up by an interrupt, then two possible situations may occur. The first is where the related interrupt is disabled or the interrupt is enabled but the stack is full, in which case the program will resume execution at the instruction following the "HALT" instruction. In this situation, the interrupt which woke-up the device will not be immediately serviced, but will rather be serviced later when the related interrupt is finally enabled or when a stack level becomes free. The other situation is where the related interrupt is enabled and the stack is not full, in which case the regular interrupt response takes place. If an interrupt request flag is set to "1" before entering the Power Down Mode, the wake-up function of the related interrupt will be disabled.

No matter what the source of the wake-up event is, once a wake-up situation occurs, a time period equal to 1024 system clock periods will be required before normal system operation resumes. However, if the wake-up has originated due to an interrupt, the actual interrupt subroutine execution will be delayed by an additional one or more cycles. If the wake-up results in the execution of the next instruction following the "HALT" instruction, this will be executed immediately after the 1024 system clock period delay has ended.

Watchdog Timer

The Watchdog Timer is provided to prevent program malfunctions or sequences from jumping to unknown locations, due to certain uncontrollable external events such as electrical noise. It operates by providing a device reset when the WDT counter overflows. The WDT clock is supplied by one of two sources selected by configuration option: its own self-contained dedicated internal WDT oscillator, or the instruction clock which is the system clock divided by 4. Note that if the WDT configuration option has been disabled, then any instruction relating to its operation will result in no operation.

The internal WDT oscillator has an approximate period of 65µs at a supply voltage of 5V. If selected, it is first divided by 256 via an 8-stage counter to give a nominal period of 17ms. Note that this period can vary with VDD, temperature and process variations. For longer WDT time-out periods the WDT prescaler can be utilized. By writing the required value to bits 0, 1 and 2 of the WDTs register, known as WS0, WS1 and WS2, longer time-out periods can be achieved. With WS0, WS1 and WS2 all equal to 1, the division ratio is 1:128 which gives a maximum time-out period of about 2.1s.

A configuration option can select the instruction clock, which is the system clock divided by 4, as the WDT clock

source instead of the internal WDT oscillator. If the instruction clock is used as the clock source, it must be noted that when the system enters the Power Down Mode, as the system clock is stopped, then the WDT clock source will also be stopped. Therefore the WDT will lose its protecting purposes. In such cases the system cannot be restarted by the WDT and can only be restarted using external signals. For systems that operate in noisy environments, using the internal WDT oscillator is therefore the recommended choice.

Under normal program operation, a WDT time-out will initialise a device reset and set the status bit TO. However, if the system is in the Power Down Mode, when a WDT time-out occurs, only the Program Counter and Stack Pointer will be reset. Three methods can be adopted to clear the contents of the WDT and the WDT prescaler. The first is an external hardware reset, which means a low level on the RES pin, the second is using the watchdog software instructions and the third is via a "HALT" instruction.

There are two methods of using software instructions to clear the Watchdog Timer, one of which must be chosen by configuration option. The first option is to use the single "CLR WDT" instruction while the second is to use the two commands "CLR WDT1" and "CLR WDT2". For the first option, a simple execution of "CLR WDT" will clear the WDT while for the second option, both "CLR WDT1" and "CLR WDT2" must both be executed to successfully clear the WDT. Note that for this second option, if "CLR WDT1" is used to clear the WDT, successive executions of this instruction will have no effect, only the execution of a "CLR WDT2" instruction will clear the WDT. Similarly, after the "CLR WDT2" instruction has been executed, only a successive "CLR WDT1" instruction can clear the Watchdog Timer.

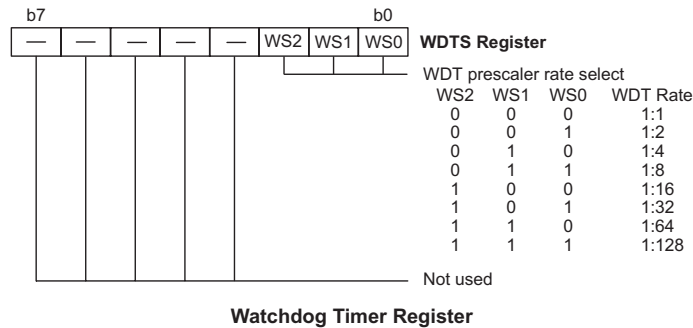

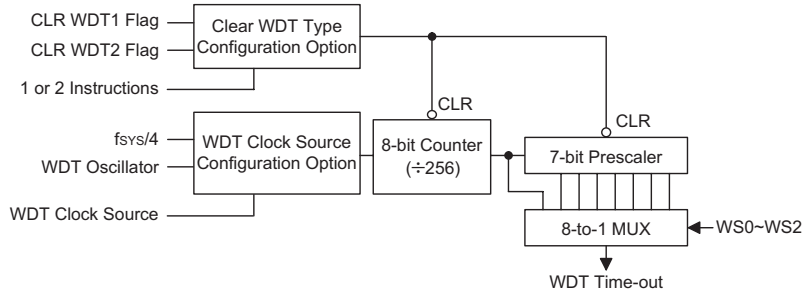

Watchdog Timer

Configuration Options

Configuration options refer to certain options within the MCU that are programmed into the Flash Type Program Memory device during the programming process. During the development process, these options are selected using the HT-IDE software development tools. As these options are programmed into the device using the hardware programming tools, once they are selected they cannot be changed later by the application software.

All options must be defined for proper system function, the details of which are shown in the table.

No.	Options
1	Watchdog Timer: enable or disable
2	Watchdog Timer clock source: WDT oscillator or $f_{SYS}/4$
3	CLRWDT instructions: 1 or 2 instructions
4	PA0~PA7: wake-up enable or disable (bit option)
5	PA, PB and PC: pull-high enable or disable (port numbers are device dependent)
6	PA input type: CMOS or Schmitt Trigger (HT48F06E excepted)
7	Buzzer function: enable or normal I/O
8	System oscillator: Crystal or RC
9	LVR function: enable or disable

Application Circuits

The following application circuit although based around the HT48F30E device equally apply to the other devices.

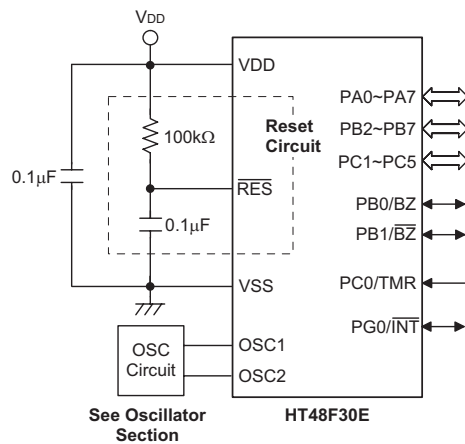

Instruction Set

Introduction

Central to the successful operation of any microcontroller is its instruction set, which is a set of program instruction codes that directs the microcontroller to perform certain operations. In the case of Holtek microcontrollers, a comprehensive and flexible set of over 60 instructions is provided to enable programmers to implement their application with the minimum of programming overheads.

For easier understanding of the various instruction codes, they have been subdivided into several functional groupings.

Instruction Timing

Most instructions are implemented within one instruction cycle. The exceptions to this are branch, call, or table read instructions where two instruction cycles are required. One instruction cycle is equal to 4 system clock cycles, therefore in the case of an 8MHz system oscillator, most instructions would be implemented within 0.5 μ s and branch or call instructions would be implemented within 1 μ s. Although instructions which require one more cycle to implement are generally limited to the JMP, CALL, RET, RETI and table read instructions, it is important to realize that any other instructions which involve manipulation of the Program Counter Low register or PCL will also take one more cycle to implement. As instructions which change the contents of the PCL will imply a direct jump to that new address, one more cycle will be required. Examples of such instructions would be "CLR PCL" or "MOV PCL, A". For the case of skip instructions, it must be noted that if the result of the comparison involves a skip operation then this will also take one more cycle, if no skip is involved then only one cycle is required.

Moving and Transferring Data

The transfer of data within the microcontroller program is one of the most frequently used operations. Making use of three kinds of MOV instructions, data can be transferred from registers to the Accumulator and vice-versa as well as being able to move specific immediate data directly into the Accumulator. One of the most important data transfer applications is to receive data from the input ports and transfer data to the output ports.

Arithmetic Operations

The ability to perform certain arithmetic operations and data manipulation is a necessary feature of most microcontroller applications. Within the Holtek microcontroller instruction set are a range of add and

subtract instruction mnemonics to enable the necessary arithmetic to be carried out. Care must be taken to ensure correct handling of carry and borrow data when results exceed 255 for addition and less than 0 for subtraction. The increment and decrement instructions INC, INCA, DEC and DECA provide a simple means of increasing or decreasing by a value of one of the values in the destination specified.

Logical and Rotate Operations

The standard logical operations such as AND, OR, XOR and CPL all have their own instruction within the Holtek microcontroller instruction set. As with the case of most instructions involving data manipulation, data must pass through the Accumulator which may involve additional programming steps. In all logical data operations, the zero flag may be set if the result of the operation is zero. Another form of logical data manipulation comes from the rotate instructions such as RR, RL, RRC and RLC which provide a simple means of rotating one bit right or left. Different rotate instructions exist depending on program requirements. Rotate instructions are useful for serial port programming applications where data can be rotated from an internal register into the Carry bit from where it can be examined and the necessary serial bit set high or low. Another application where rotate data operations are used is to implement multiplication and division calculations.

Branches and Control Transfer

Program branching takes the form of either jumps to specified locations using the JMP instruction or to a subroutine using the CALL instruction. They differ in the sense that in the case of a subroutine call, the program must return to the instruction immediately when the subroutine has been carried out. This is done by placing a return instruction RET in the subroutine which will cause the program to jump back to the address right after the CALL instruction. In the case of a JMP instruction, the program simply jumps to the desired location. There is no requirement to jump back to the original jumping off point as in the case of the CALL instruction. One special and extremely useful set of branch instructions are the conditional branches. Here a decision is first made regarding the condition of a certain data memory or individual bits. Depending upon the conditions, the program will continue with the next instruction or skip over it and jump to the following instruction. These instructions are the key to decision making and branching within the program perhaps determined by the condition of certain input switches or by the condition of internal data bits.

Bit Operations

The ability to provide single bit operations on Data Memory is an extremely flexible feature of all Holtek microcontrollers. This feature is especially useful for output port bit programming where individual bits or port pins can be directly set high or low using either the "SET [m].i" or "CLR [m].i" instructions respectively. The feature removes the need for programmers to first read the 8-bit output port, manipulate the input data to ensure that other bits are not changed and then output the port with the correct new data. This read-modify-write process is taken care of automatically when these bit operation instructions are used.

Table Read Operations

Data storage is normally implemented by using registers. However, when working with large amounts of fixed data, the volume involved often makes it inconvenient to store the fixed data in the Data Memory. To overcome this problem, Holtek microcontrollers allow an area of Program Memory to be setup as a table where data can be directly stored. A set of easy to use instructions provides the means by which this fixed data can be referenced and retrieved from the Program Memory.

Other Operations

In addition to the above functional instructions, a range of other instructions also exist such as the "HALT" instruction for Power-down operations and instructions to control the operation of the Watchdog Timer for reliable program operations under extreme electric or electro-magnetic environments. For their relevant operations, refer to the functional related sections.

Instruction Set Summary

The following table depicts a summary of the instruction set categorised according to function and can be consulted as a basic instruction reference using the following listed conventions.

Table conventions:

x: Bits immediate data

m: Data Memory address

A: Accumulator

i: 0~7 number of bits

addr: Program memory address

Mnemonic	Description	Cycles	Flag Affected
Arithmetic			
ADD A,[m]	Add Data Memory to ACC	1	Z, C, AC, OV
ADDM A,[m]	Add ACC to Data Memory	1 ^{Note}	Z, C, AC, OV
ADD A,x	Add immediate data to ACC	1	Z, C, AC, OV
ADC A,[m]	Add Data Memory to ACC with Carry	1	Z, C, AC, OV
ADCM A,[m]	Add ACC to Data memory with Carry	1 ^{Note}	Z, C, AC, OV
SUB A,x	Subtract immediate data from the ACC	1	Z, C, AC, OV
SUB A,[m]	Subtract Data Memory from ACC	1	Z, C, AC, OV
SUBM A,[m]	Subtract Data Memory from ACC with result in Data Memory	1 ^{Note}	Z, C, AC, OV
SBC A,[m]	Subtract Data Memory from ACC with Carry	1	Z, C, AC, OV
SBCM A,[m]	Subtract Data Memory from ACC with Carry, result in Data Memory	1 ^{Note}	Z, C, AC, OV
DAA [m]	Decimal adjust ACC for Addition with result in Data Memory	1 ^{Note}	C
Logic Operation			
AND A,[m]	Logical AND Data Memory to ACC	1	Z
OR A,[m]	Logical OR Data Memory to ACC	1	Z
XOR A,[m]	Logical XOR Data Memory to ACC	1	Z
ANDM A,[m]	Logical AND ACC to Data Memory	1 ^{Note}	Z
ORM A,[m]	Logical OR ACC to Data Memory	1 ^{Note}	Z
XORM A,[m]	Logical XOR ACC to Data Memory	1 ^{Note}	Z
AND A,x	Logical AND immediate Data to ACC	1	Z
OR A,x	Logical OR immediate Data to ACC	1	Z
XOR A,x	Logical XOR immediate Data to ACC	1	Z
CPL [m]	Complement Data Memory	1 ^{Note}	Z
CPLA [m]	Complement Data Memory with result in ACC	1	Z
Increment & Decrement			
INCA [m]	Increment Data Memory with result in ACC	1	Z
INC [m]	Increment Data Memory	1 ^{Note}	Z
DECA [m]	Decrement Data Memory with result in ACC	1	Z
DEC [m]	Decrement Data Memory	1 ^{Note}	Z

Mnemonic	Description	Cycles	Flag Affected
Rotate			
RRA [m]	Rotate Data Memory right with result in ACC	1	None
RR [m]	Rotate Data Memory right	1 ^{Note}	None
RRCA [m]	Rotate Data Memory right through Carry with result in ACC	1	C
RRC [m]	Rotate Data Memory right through Carry	1 ^{Note}	C
RLA [m]	Rotate Data Memory left with result in ACC	1	None
RL [m]	Rotate Data Memory left	1 ^{Note}	None
RLCA [m]	Rotate Data Memory left through Carry with result in ACC	1	C
RLC [m]	Rotate Data Memory left through Carry	1 ^{Note}	C
Data Move			
MOV A,[m]	Move Data Memory to ACC	1	None
MOV [m],A	Move ACC to Data Memory	1 ^{Note}	None
MOV A,x	Move immediate data to ACC	1	None
Bit Operation			
CLR [m].i	Clear bit of Data Memory	1 ^{Note}	None
SET [m].i	Set bit of Data Memory	1 ^{Note}	None
Branch			
JMP addr	Jump unconditionally	2	None
SZ [m]	Skip if Data Memory is zero	1 ^{Note}	None
SZA [m]	Skip if Data Memory is zero with data movement to ACC	1 ^{Note}	None
SZ [m].i	Skip if bit i of Data Memory is zero	1 ^{Note}	None
SNZ [m].i	Skip if bit i of Data Memory is not zero	1 ^{Note}	None
SIZ [m]	Skip if increment Data Memory is zero	1 ^{Note}	None
SDZ [m]	Skip if decrement Data Memory is zero	1 ^{Note}	None
SIZA [m]	Skip if increment Data Memory is zero with result in ACC	1 ^{Note}	None
SDZA [m]	Skip if decrement Data Memory is zero with result in ACC	1 ^{Note}	None
CALL addr	Subroutine call	2	None
RET	Return from subroutine	2	None
RET A,x	Return from subroutine and load immediate data to ACC	2	None
RETI	Return from interrupt	2	None
Table Read			
TABRDC [m]	Read table (current page) to TBLH and Data Memory	2 ^{Note}	None
TABRDL [m]	Read table (last page) to TBLH and Data Memory	2 ^{Note}	None
Miscellaneous			
NOP	No operation	1	None
CLR [m]	Clear Data Memory	1 ^{Note}	None
SET [m]	Set Data Memory	1 ^{Note}	None
CLR WDT	Clear Watchdog Timer	1	TO, PDF
CLR WDT1	Pre-clear Watchdog Timer	1	TO, PDF
CLR WDT2	Pre-clear Watchdog Timer	1	TO, PDF
SWAP [m]	Swap nibbles of Data Memory	1 ^{Note}	None
SWAPA [m]	Swap nibbles of Data Memory with result in ACC	1	None
HALT	Enter power down mode	1	TO, PDF

- Note:
- For skip instructions, if the result of the comparison involves a skip then two cycles are required, if no skip takes place only one cycle is required.
 - Any instruction which changes the contents of the PCL will also require 2 cycles for execution.
 - For the "CLR WDT1" and "CLR WDT2" instructions the TO and PDF flags may be affected by the execution status. The TO and PDF flags are cleared after both "CLR WDT1" and "CLR WDT2" instructions are consecutively executed. Otherwise the TO and PDF flags remain unchanged.

Instruction Definition

ADC A,[m]	Add Data Memory to ACC with Carry
Description	The contents of the specified Data Memory, Accumulator and the carry flag are added. The result is stored in the Accumulator.
Operation	$ACC \leftarrow ACC + [m] + C$
Affected flag(s)	OV, Z, AC, C
ADCM A,[m]	Add ACC to Data Memory with Carry
Description	The contents of the specified Data Memory, Accumulator and the carry flag are added. The result is stored in the specified Data Memory.
Operation	$[m] \leftarrow ACC + [m] + C$
Affected flag(s)	OV, Z, AC, C
ADD A,[m]	Add Data Memory to ACC
Description	The contents of the specified Data Memory and the Accumulator are added. The result is stored in the Accumulator.
Operation	$ACC \leftarrow ACC + [m]$
Affected flag(s)	OV, Z, AC, C
ADD A,x	Add immediate data to ACC
Description	The contents of the Accumulator and the specified immediate data are added. The result is stored in the Accumulator.
Operation	$ACC \leftarrow ACC + x$
Affected flag(s)	OV, Z, AC, C
ADDM A,[m]	Add ACC to Data Memory
Description	The contents of the specified Data Memory and the Accumulator are added. The result is stored in the specified Data Memory.
Operation	$[m] \leftarrow ACC + [m]$
Affected flag(s)	OV, Z, AC, C
AND A,[m]	Logical AND Data Memory to ACC
Description	Data in the Accumulator and the specified Data Memory perform a bitwise logical AND operation. The result is stored in the Accumulator.
Operation	$ACC \leftarrow ACC \text{ "AND" } [m]$
Affected flag(s)	Z
AND A,x	Logical AND immediate data to ACC
Description	Data in the Accumulator and the specified immediate data perform a bitwise logical AND operation. The result is stored in the Accumulator.
Operation	$ACC \leftarrow ACC \text{ "AND" } x$
Affected flag(s)	Z
ANDM A,[m]	Logical AND ACC to Data Memory
Description	Data in the specified Data Memory and the Accumulator perform a bitwise logical AND operation. The result is stored in the Data Memory.
Operation	$[m] \leftarrow ACC \text{ "AND" } [m]$
Affected flag(s)	Z

CALL addr	Subroutine call
Description	Unconditionally calls a subroutine at the specified address. The Program Counter then increments by 1 to obtain the address of the next instruction which is then pushed onto the stack. The specified address is then loaded and the program continues execution from this new address. As this instruction requires an additional operation, it is a two cycle instruction.
Operation	Stack \leftarrow Program Counter + 1 Program Counter \leftarrow addr
Affected flag(s)	None
CLR [m]	Clear Data Memory
Description	Each bit of the specified Data Memory is cleared to 0.
Operation	[m] \leftarrow 00H
Affected flag(s)	None
CLR [m].i	Clear bit of Data Memory
Description	Bit i of the specified Data Memory is cleared to 0.
Operation	[m].i \leftarrow 0
Affected flag(s)	None
CLR WDT	Clear Watchdog Timer
Description	The TO, PDF flags and the WDT are all cleared.
Operation	WDT cleared TO \leftarrow 0 PDF \leftarrow 0
Affected flag(s)	TO, PDF
CLR WDT1	Pre-clear Watchdog Timer
Description	The TO, PDF flags and the WDT are all cleared. Note that this instruction works in conjunction with CLR WDT2 and must be executed alternately with CLR WDT2 to have effect. Repeatedly executing this instruction without alternately executing CLR WDT2 will have no effect.
Operation	WDT cleared TO \leftarrow 0 PDF \leftarrow 0
Affected flag(s)	TO, PDF
CLR WDT2	Pre-clear Watchdog Timer
Description	The TO, PDF flags and the WDT are all cleared. Note that this instruction works in conjunction with CLR WDT1 and must be executed alternately with CLR WDT1 to have effect. Repeatedly executing this instruction without alternately executing CLR WDT1 will have no effect.
Operation	WDT cleared TO \leftarrow 0 PDF \leftarrow 0
Affected flag(s)	TO, PDF

CPL [m]	Complement Data Memory
Description	Each bit of the specified Data Memory is logically complemented (1's complement). Bits which previously contained a 1 are changed to 0 and vice versa.
Operation	$[m] \leftarrow \overline{[m]}$
Affected flag(s)	Z
CPLA [m]	Complement Data Memory with result in ACC
Description	Each bit of the specified Data Memory is logically complemented (1's complement). Bits which previously contained a 1 are changed to 0 and vice versa. The complemented result is stored in the Accumulator and the contents of the Data Memory remain unchanged.
Operation	$ACC \leftarrow \overline{[m]}$
Affected flag(s)	Z
DAA [m]	Decimal-Adjust ACC for addition with result in Data Memory
Description	Convert the contents of the Accumulator value to a BCD (Binary Coded Decimal) value resulting from the previous addition of two BCD variables. If the low nibble is greater than 9 or if AC flag is set, then a value of 6 will be added to the low nibble. Otherwise the low nibble remains unchanged. If the high nibble is greater than 9 or if the C flag is set, then a value of 6 will be added to the high nibble. Essentially, the decimal conversion is performed by adding 00H, 06H, 60H or 66H depending on the Accumulator and flag conditions. Only the C flag may be affected by this instruction which indicates that if the original BCD sum is greater than 100, it allows multiple precision decimal addition.
Operation	$[m] \leftarrow ACC + 00H$ or $[m] \leftarrow ACC + 06H$ or $[m] \leftarrow ACC + 60H$ or $[m] \leftarrow ACC + 66H$
Affected flag(s)	C
DEC [m]	Decrement Data Memory
Description	Data in the specified Data Memory is decremented by 1.
Operation	$[m] \leftarrow [m] - 1$
Affected flag(s)	Z
DECA [m]	Decrement Data Memory with result in ACC
Description	Data in the specified Data Memory is decremented by 1. The result is stored in the Accumulator. The contents of the Data Memory remain unchanged.
Operation	$ACC \leftarrow [m] - 1$
Affected flag(s)	Z
HALT	Enter power down mode
Description	This instruction stops the program execution and turns off the system clock. The contents of the Data Memory and registers are retained. The WDT and prescaler are cleared. The power down flag PDF is set and the WDT time-out flag TO is cleared.
Operation	TO \leftarrow 0 PDF \leftarrow 1
Affected flag(s)	TO, PDF

INC [m]	Increment Data Memory
Description	Data in the specified Data Memory is incremented by 1.
Operation	$[m] \leftarrow [m] + 1$
Affected flag(s)	Z
INCA [m]	Increment Data Memory with result in ACC
Description	Data in the specified Data Memory is incremented by 1. The result is stored in the Accumulator. The contents of the Data Memory remain unchanged.
Operation	$ACC \leftarrow [m] + 1$
Affected flag(s)	Z
JMP addr	Jump unconditionally
Description	The contents of the Program Counter are replaced with the specified address. Program execution then continues from this new address. As this requires the insertion of a dummy instruction while the new address is loaded, it is a two cycle instruction.
Operation	$Program\ Counter \leftarrow addr$
Affected flag(s)	None
MOV A,[m]	Move Data Memory to ACC
Description	The contents of the specified Data Memory are copied to the Accumulator.
Operation	$ACC \leftarrow [m]$
Affected flag(s)	None
MOV A,x	Move immediate data to ACC
Description	The immediate data specified is loaded into the Accumulator.
Operation	$ACC \leftarrow x$
Affected flag(s)	None
MOV [m],A	Move ACC to Data Memory
Description	The contents of the Accumulator are copied to the specified Data Memory.
Operation	$[m] \leftarrow ACC$
Affected flag(s)	None
NOP	No operation
Description	No operation is performed. Execution continues with the next instruction.
Operation	No operation
Affected flag(s)	None
OR A,[m]	Logical OR Data Memory to ACC
Description	Data in the Accumulator and the specified Data Memory perform a bitwise logical OR operation. The result is stored in the Accumulator.
Operation	$ACC \leftarrow ACC \text{ "OR" } [m]$
Affected flag(s)	Z

OR A,x	Logical OR immediate data to ACC
Description	Data in the Accumulator and the specified immediate data perform a bitwise logical OR operation. The result is stored in the Accumulator.
Operation	$ACC \leftarrow ACC \text{ "OR" } x$
Affected flag(s)	Z
ORM A,[m]	Logical OR ACC to Data Memory
Description	Data in the specified Data Memory and the Accumulator perform a bitwise logical OR operation. The result is stored in the Data Memory.
Operation	$[m] \leftarrow ACC \text{ "OR" } [m]$
Affected flag(s)	Z
RET	Return from subroutine
Description	The Program Counter is restored from the stack. Program execution continues at the restored address.
Operation	Program Counter \leftarrow Stack
Affected flag(s)	None
RET A,x	Return from subroutine and load immediate data to ACC
Description	The Program Counter is restored from the stack and the Accumulator loaded with the specified immediate data. Program execution continues at the restored address.
Operation	Program Counter \leftarrow Stack $ACC \leftarrow x$
Affected flag(s)	None
RETI	Return from interrupt
Description	The Program Counter is restored from the stack and the interrupts are re-enabled by setting the EMI bit. EMI is the master interrupt global enable bit. If an interrupt was pending when the RETI instruction is executed, the pending Interrupt routine will be processed before returning to the main program.
Operation	Program Counter \leftarrow Stack $EMI \leftarrow 1$
Affected flag(s)	None
RL [m]	Rotate Data Memory left
Description	The contents of the specified Data Memory are rotated left by 1 bit with bit 7 rotated into bit 0.
Operation	$[m].(i+1) \leftarrow [m].i; (i = 0-6)$ $[m].0 \leftarrow [m].7$
Affected flag(s)	None
RLA [m]	Rotate Data Memory left with result in ACC
Description	The contents of the specified Data Memory are rotated left by 1 bit with bit 7 rotated into bit 0. The rotated result is stored in the Accumulator and the contents of the Data Memory remain unchanged.
Operation	$ACC.(i+1) \leftarrow [m].i; (i = 0-6)$ $ACC.0 \leftarrow [m].7$
Affected flag(s)	None

RLC [m]	Rotate Data Memory left through Carry
Description	The contents of the specified Data Memory and the carry flag are rotated left by 1 bit. Bit 7 replaces the Carry bit and the original carry flag is rotated into bit 0.
Operation	$[m].(i+1) \leftarrow [m].i; (i = 0-6)$ $[m].0 \leftarrow C$ $C \leftarrow [m].7$
Affected flag(s)	C
RLCA [m]	Rotate Data Memory left through Carry with result in ACC
Description	Data in the specified Data Memory and the carry flag are rotated left by 1 bit. Bit 7 replaces the Carry bit and the original carry flag is rotated into the bit 0. The rotated result is stored in the Accumulator and the contents of the Data Memory remain unchanged.
Operation	$ACC.(i+1) \leftarrow [m].i; (i = 0-6)$ $ACC.0 \leftarrow C$ $C \leftarrow [m].7$
Affected flag(s)	C
RR [m]	Rotate Data Memory right
Description	The contents of the specified Data Memory are rotated right by 1 bit with bit 0 rotated into bit 7.
Operation	$[m].i \leftarrow [m].(i+1); (i = 0-6)$ $[m].7 \leftarrow [m].0$
Affected flag(s)	None
RRA [m]	Rotate Data Memory right with result in ACC
Description	Data in the specified Data Memory and the carry flag are rotated right by 1 bit with bit 0 rotated into bit 7. The rotated result is stored in the Accumulator and the contents of the Data Memory remain unchanged.
Operation	$ACC.i \leftarrow [m].(i+1); (i = 0-6)$ $ACC.7 \leftarrow [m].0$
Affected flag(s)	None
RRC [m]	Rotate Data Memory right through Carry
Description	The contents of the specified Data Memory and the carry flag are rotated right by 1 bit. Bit 0 replaces the Carry bit and the original carry flag is rotated into bit 7.
Operation	$[m].i \leftarrow [m].(i+1); (i = 0-6)$ $[m].7 \leftarrow C$ $C \leftarrow [m].0$
Affected flag(s)	C
RRCA [m]	Rotate Data Memory right through Carry with result in ACC
Description	Data in the specified Data Memory and the carry flag are rotated right by 1 bit. Bit 0 replaces the Carry bit and the original carry flag is rotated into bit 7. The rotated result is stored in the Accumulator and the contents of the Data Memory remain unchanged.
Operation	$ACC.i \leftarrow [m].(i+1); (i = 0-6)$ $ACC.7 \leftarrow C$ $C \leftarrow [m].0$
Affected flag(s)	C

SBC A,[m]	Subtract Data Memory from ACC with Carry
Description	The contents of the specified Data Memory and the complement of the carry flag are subtracted from the Accumulator. The result is stored in the Accumulator. Note that if the result of subtraction is negative, the C flag will be cleared to 0, otherwise if the result is positive or zero, the C flag will be set to 1.
Operation	$ACC \leftarrow ACC - [m] - \bar{C}$
Affected flag(s)	OV, Z, AC, C
SBCM A,[m]	Subtract Data Memory from ACC with Carry and result in Data Memory
Description	The contents of the specified Data Memory and the complement of the carry flag are subtracted from the Accumulator. The result is stored in the Data Memory. Note that if the result of subtraction is negative, the C flag will be cleared to 0, otherwise if the result is positive or zero, the C flag will be set to 1.
Operation	$[m] \leftarrow ACC - [m] - \bar{C}$
Affected flag(s)	OV, Z, AC, C
SDZ [m]	Skip if decrement Data Memory is 0
Description	The contents of the specified Data Memory are first decremented by 1. If the result is 0 the following instruction is skipped. As this requires the insertion of a dummy instruction while the next instruction is fetched, it is a two cycle instruction. If the result is not 0 the program proceeds with the following instruction.
Operation	$[m] \leftarrow [m] - 1$ Skip if $[m] = 0$
Affected flag(s)	None
SDZA [m]	Skip if decrement Data Memory is zero with result in ACC
Description	The contents of the specified Data Memory are first decremented by 1. If the result is 0, the following instruction is skipped. The result is stored in the Accumulator but the specified Data Memory contents remain unchanged. As this requires the insertion of a dummy instruction while the next instruction is fetched, it is a two cycle instruction. If the result is not 0, the program proceeds with the following instruction.
Operation	$ACC \leftarrow [m] - 1$ Skip if $ACC = 0$
Affected flag(s)	None
SET [m]	Set Data Memory
Description	Each bit of the specified Data Memory is set to 1.
Operation	$[m] \leftarrow FFH$
Affected flag(s)	None
SET [m].i	Set bit of Data Memory
Description	Bit i of the specified Data Memory is set to 1.
Operation	$[m].i \leftarrow 1$
Affected flag(s)	None

SIZ [m]	Skip if increment Data Memory is 0
Description	The contents of the specified Data Memory are first incremented by 1. If the result is 0, the following instruction is skipped. As this requires the insertion of a dummy instruction while the next instruction is fetched, it is a two cycle instruction. If the result is not 0 the program proceeds with the following instruction.
Operation	$[m] \leftarrow [m] + 1$ Skip if $[m] = 0$
Affected flag(s)	None
SIZA [m]	Skip if increment Data Memory is zero with result in ACC
Description	The contents of the specified Data Memory are first incremented by 1. If the result is 0, the following instruction is skipped. The result is stored in the Accumulator but the specified Data Memory contents remain unchanged. As this requires the insertion of a dummy instruction while the next instruction is fetched, it is a two cycle instruction. If the result is not 0 the program proceeds with the following instruction.
Operation	$ACC \leftarrow [m] + 1$ Skip if $ACC = 0$
Affected flag(s)	None
SNZ [m].i	Skip if bit i of Data Memory is not 0
Description	If bit i of the specified Data Memory is not 0, the following instruction is skipped. As this requires the insertion of a dummy instruction while the next instruction is fetched, it is a two cycle instruction. If the result is 0 the program proceeds with the following instruction.
Operation	Skip if $[m].i \neq 0$
Affected flag(s)	None
SUB A,[m]	Subtract Data Memory from ACC
Description	The specified Data Memory is subtracted from the contents of the Accumulator. The result is stored in the Accumulator. Note that if the result of subtraction is negative, the C flag will be cleared to 0, otherwise if the result is positive or zero, the C flag will be set to 1.
Operation	$ACC \leftarrow ACC - [m]$
Affected flag(s)	OV, Z, AC, C
SUBM A,[m]	Subtract Data Memory from ACC with result in Data Memory
Description	The specified Data Memory is subtracted from the contents of the Accumulator. The result is stored in the Data Memory. Note that if the result of subtraction is negative, the C flag will be cleared to 0, otherwise if the result is positive or zero, the C flag will be set to 1.
Operation	$[m] \leftarrow ACC - [m]$
Affected flag(s)	OV, Z, AC, C
SUB A,x	Subtract immediate data from ACC
Description	The immediate data specified by the code is subtracted from the contents of the Accumulator. The result is stored in the Accumulator. Note that if the result of subtraction is negative, the C flag will be cleared to 0, otherwise if the result is positive or zero, the C flag will be set to 1.
Operation	$ACC \leftarrow ACC - x$
Affected flag(s)	OV, Z, AC, C

SWAP [m]	Swap nibbles of Data Memory
Description	The low-order and high-order nibbles of the specified Data Memory are interchanged.
Operation	$[m].3 \sim [m].0 \leftrightarrow [m].7 \sim [m].4$
Affected flag(s)	None
SWAPA [m]	Swap nibbles of Data Memory with result in ACC
Description	The low-order and high-order nibbles of the specified Data Memory are interchanged. The result is stored in the Accumulator. The contents of the Data Memory remain unchanged.
Operation	$ACC.3 \sim ACC.0 \leftarrow [m].7 \sim [m].4$ $ACC.7 \sim ACC.4 \leftarrow [m].3 \sim [m].0$
Affected flag(s)	None
SZ [m]	Skip if Data Memory is 0
Description	If the contents of the specified Data Memory is 0, the following instruction is skipped. As this requires the insertion of a dummy instruction while the next instruction is fetched, it is a two cycle instruction. If the result is not 0 the program proceeds with the following instruction.
Operation	Skip if $[m] = 0$
Affected flag(s)	None
SZA [m]	Skip if Data Memory is 0 with data movement to ACC
Description	The contents of the specified Data Memory are copied to the Accumulator. If the value is zero, the following instruction is skipped. As this requires the insertion of a dummy instruction while the next instruction is fetched, it is a two cycle instruction. If the result is not 0 the program proceeds with the following instruction.
Operation	$ACC \leftarrow [m]$ Skip if $[m] = 0$
Affected flag(s)	None
SZ [m].i	Skip if bit i of Data Memory is 0
Description	If bit i of the specified Data Memory is 0, the following instruction is skipped. As this requires the insertion of a dummy instruction while the next instruction is fetched, it is a two cycle instruction. If the result is not 0, the program proceeds with the following instruction.
Operation	Skip if $[m].i = 0$
Affected flag(s)	None
TABRDC [m]	Read table (current page) to TBLH and Data Memory
Description	The low byte of the program code (current page) addressed by the table pointer (TBLP) is moved to the specified Data Memory and the high byte moved to TBLH.
Operation	$[m] \leftarrow$ program code (low byte) $TBLH \leftarrow$ program code (high byte)
Affected flag(s)	None
TABRDL [m]	Read table (last page) to TBLH and Data Memory
Description	The low byte of the program code (last page) addressed by the table pointer (TBLP) is moved to the specified Data Memory and the high byte moved to TBLH.
Operation	$[m] \leftarrow$ program code (low byte) $TBLH \leftarrow$ program code (high byte)
Affected flag(s)	None

XOR A,[m]	Logical XOR Data Memory to ACC
Description	Data in the Accumulator and the specified Data Memory perform a bitwise logical XOR operation. The result is stored in the Accumulator.
Operation	ACC ← ACC "XOR" [m]
Affected flag(s)	Z
XORM A,[m]	Logical XOR ACC to Data Memory
Description	Data in the specified Data Memory and the Accumulator perform a bitwise logical XOR operation. The result is stored in the Data Memory.
Operation	[m] ← ACC "XOR" [m]
Affected flag(s)	Z
XOR A,x	Logical XOR immediate data to ACC
Description	Data in the Accumulator and the specified immediate data perform a bitwise logical XOR operation. The result is stored in the Accumulator.
Operation	ACC ← ACC "XOR" x
Affected flag(s)	Z

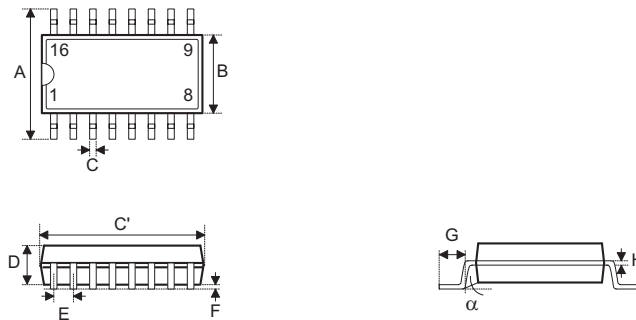
Package Information
16-pin NSOP (150mil) Outline Dimensions

Symbol	Dimensions in mil		
	Min.	Nom.	Max.
A	228	—	244
B	149	—	157
C	14	—	20
C'	386	—	394
D	53	—	69
E	—	50	—
F	4	—	10
G	22	—	28
H	4	—	12
α	0°	—	10°

18-pin DIP (300mil) Outline Dimensions

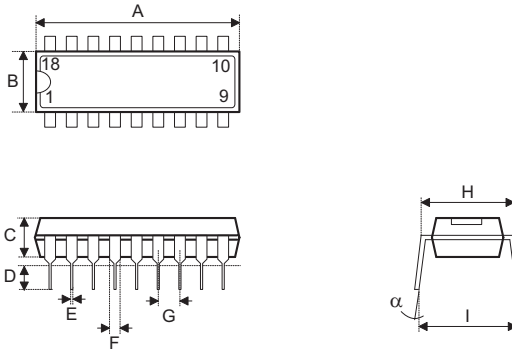

Symbol	Dimensions in mil		
	Min.	Nom.	Max.
A	895	—	915
B	240	—	260
C	125	—	135
D	125	—	145
E	16	—	20
F	50	—	70
G	—	100	—
H	295	—	315
I	335	—	375
α	0°	—	15°

18-pin SOP (300mil) Outline Dimensions

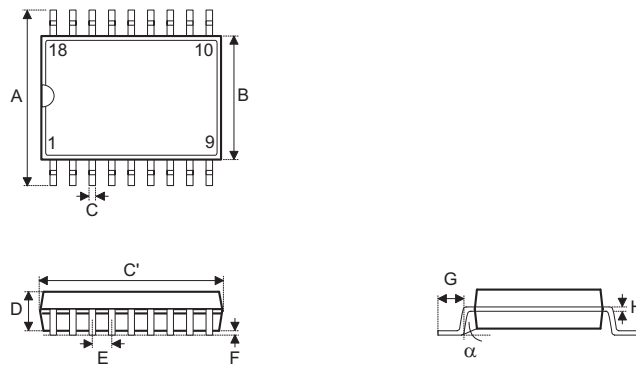

Symbol	Dimensions in mil		
	Min.	Nom.	Max.
A	394	—	419
B	290	—	300
C	14	—	20
C'	447	—	460
D	92	—	104
E	—	50	—
F	4	—	—
G	32	—	38
H	4	—	12
α	0°	—	10°

20-pin SSOP (150mil) Outline Dimensions

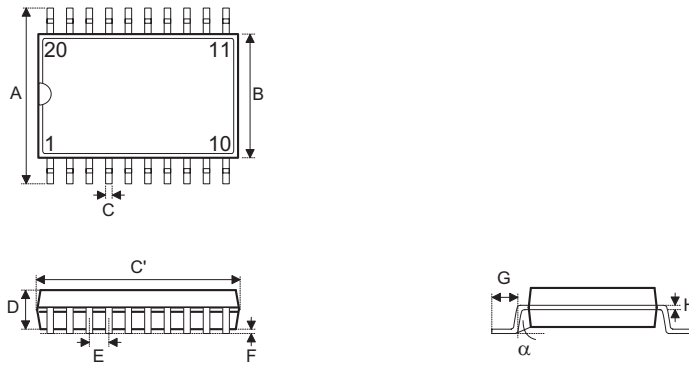

Symbol	Dimensions in mil		
	Min.	Nom.	Max.
A	228	—	244
B	150	—	158
C	8	—	12
C'	335	—	347
D	49	—	65
E	—	25	—
F	4	—	10
G	15	—	50
H	7	—	10
α	0°	—	8°

24-pin SKDIP (300mil) Outline Dimensions

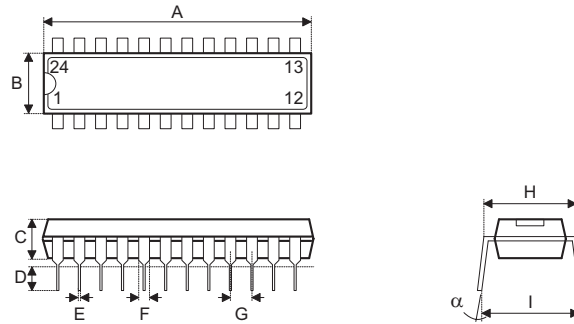

Symbol	Dimensions in mil		
	Min.	Nom.	Max.
A	1235	—	1265
B	255	—	265
C	125	—	135
D	125	—	145
E	16	—	20
F	50	—	70
G	—	100	—
H	295	—	315
I	345	—	360
α	0°	—	15°

24-pin SOP (300mil) Outline Dimensions

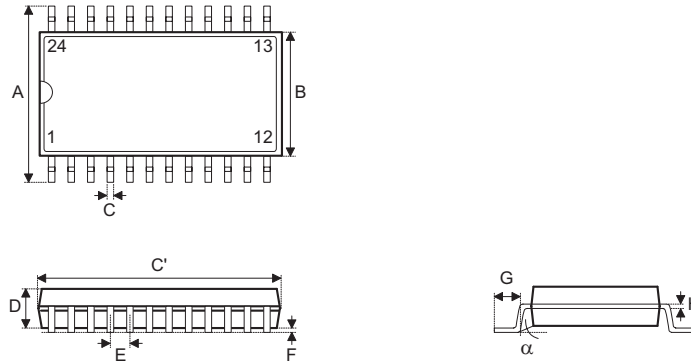

Symbol	Dimensions in mil		
	Min.	Nom.	Max.
A	394	—	419
B	290	—	300
C	14	—	20
C'	590	—	614
D	92	—	104
E	—	50	—
F	4	—	—
G	32	—	38
H	4	—	12
α	0°	—	10°

24-pin SSOP (150mil) Outline Dimensions

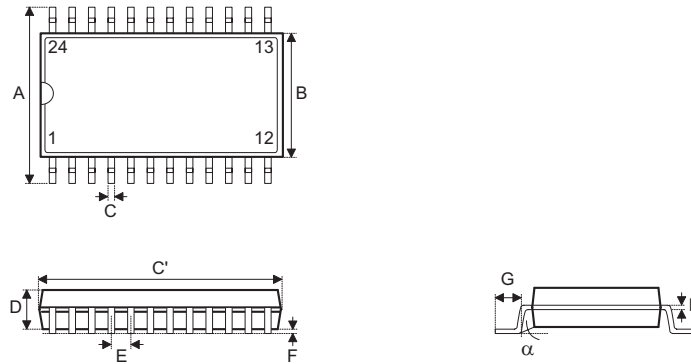

Symbol	Dimensions in mil		
	Min.	Nom.	Max.
A	228	—	244
B	150	—	157
C	8	—	12
C'	335	—	346
D	54	—	60
E	—	25	—
F	4	—	10
G	22	—	28
H	7	—	10
α	0°	—	8°

28-pin SKDIP (300mil) Outline Dimensions

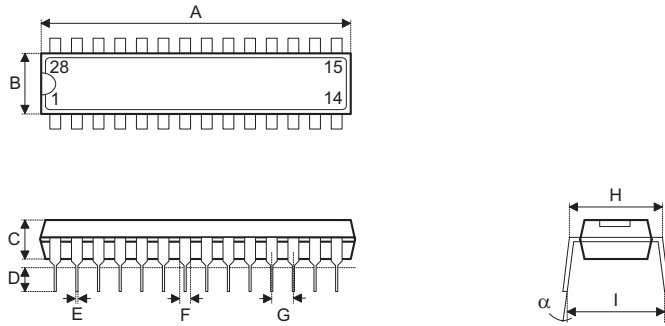

Symbol	Dimensions in mil		
	Min.	Nom.	Max.
A	1375	—	1395
B	278	—	298
C	125	—	135
D	125	—	145
E	16	—	20
F	50	—	70
G	—	100	—
H	295	—	315
I	330	—	375
α	0°	—	15°

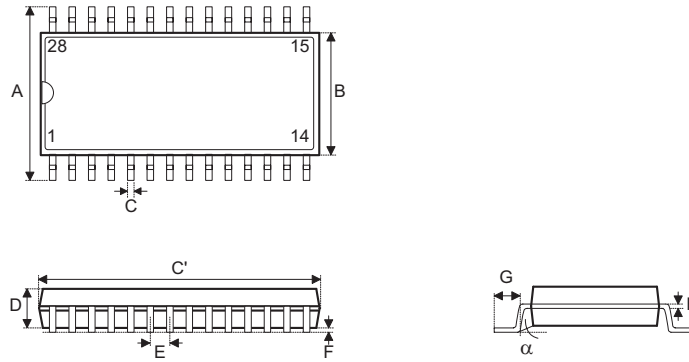
28-pin SOP (300mil) Outline Dimensions

Symbol	Dimensions in mil		
	Min.	Nom.	Max.
A	394	—	419
B	290	—	300
C	14	—	20
C'	697	—	713
D	92	—	104
E	—	50	—
F	4	—	—
G	32	—	38
H	4	—	12
α	0°	—	10°

28-pin SSOP (150mil) Outline Dimensions

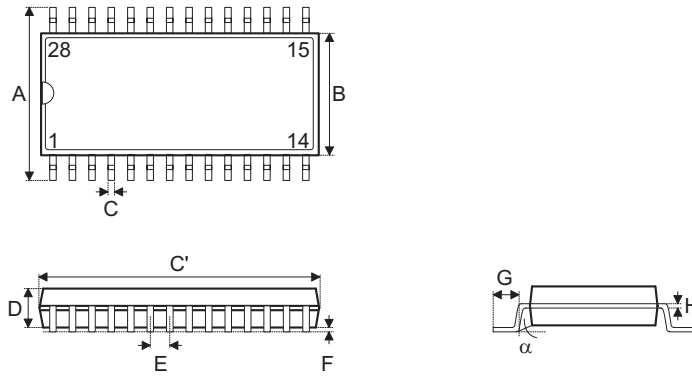

Symbol	Dimensions in mil		
	Min.	Nom.	Max.
A	228	—	244
B	150	—	157
C	8	—	12
C'	386	—	394
D	54	—	60
E	—	25	—
F	4	—	10
G	22	—	28
H	7	—	10
α	0°	—	8°

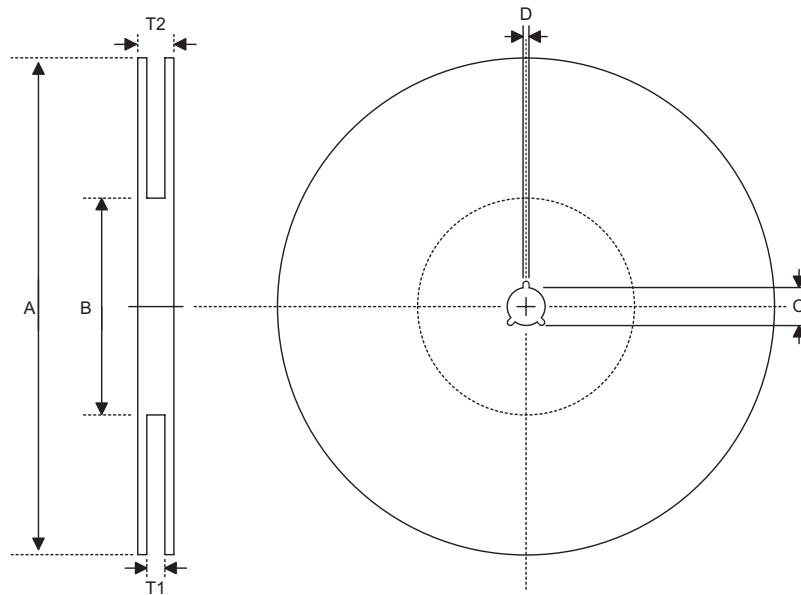
Product Tape and Reel Specifications
Reel Dimensions

SOP 16N (150mil)

Symbol	Description	Dimensions in mm
A	Reel Outer Diameter	330±1
B	Reel Inner Diameter	62±1.5
C	Spindle Hole Diameter	13+0.5 -0.2
D	Key Slit Width	2±0.5
T1	Space Between Flange	16.8+0.3 -0.2
T2	Reel Thickness	22.2±0.2

SOP 18W

Symbol	Description	Dimensions in mm
A	Reel Outer Diameter	330±1.0
B	Reel Inner Diameter	62±1.5
C	Spindle Hole Diameter	13.0+0.5 -0.2
D	Key Slit Width	2.0±0.5
T1	Space Between Flange	24.8+0.3 -0.2
T2	Reel Thickness	30.2±0.2

SSOP 20S (150mil)

Symbol	Description	Dimensions in mm
A	Reel Outer Diameter	330±1
B	Reel Inner Diameter	62±1.5
C	Spindle Hole Diameter	13+0.5 -0.2
D	Key Slit Width	2±0.5
T1	Space Between Flange	16.8+0.3 -0.2
T2	Reel Thickness	22.2±0.2

SOP 24W

Symbol	Description	Dimensions in mm
A	Reel Outer Diameter	330±1
B	Reel Inner Diameter	62±1.5
C	Spindle Hole Diameter	13+0.5 -0.2
D	Key Slit Width	2±0.5
T1	Space Between Flange	24.8+0.3 -0.2
T2	Reel Thickness	30.2±0.2

SSOP 24S (150mil)

Symbol	Description	Dimensions in mm
A	Reel Outer Diameter	330±1
B	Reel Inner Diameter	62±1.5
C	Spindle Hole Diameter	13+0.5 -0.2
D	Key Slit Width	2±0.5
T1	Space Between Flange	16.8+0.3 -0.2
T2	Reel Thickness	22.2±0.2

SOP 28W (300mil)

Symbol	Description	Dimensions in mm
A	Reel Outer Diameter	330±1
B	Reel Inner Diameter	62±1.5
C	Spindle Hole Diameter	13+0.5 -0.2
D	Key Slit Width	2±0.5
T1	Space Between Flange	24.8+0.3 -0.2
T2	Reel Thickness	30.2±0.2

SSOP 28S (150mil)

Symbol	Description	Dimensions in mm
A	Reel Outer Diameter	330±1
B	Reel Inner Diameter	62±1.5
C	Spindle Hole Diameter	13+0.5 -0.2
D	Key Slit Width	2±0.5
T1	Space Between Flange	16.8+0.3 -0.2
T2	Reel Thickness	22.2±0.2

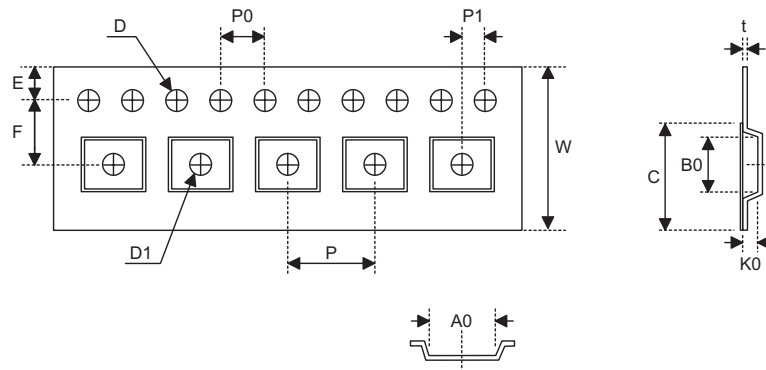
Carrier Tape Dimensions

SOP 16N (150mil)

Symbol	Description	Dimensions in mm
W	Carrier Tape Width	16±0.3
P	Cavity Pitch	8±0.1
E	Perforation Position	1.75±0.1
F	Cavity to Perforation (Width Direction)	7.5±0.1
D	Perforation Diameter	1.55±0.1
D1	Cavity Hole Diameter	1.5±0.25
P0	Perforation Pitch	4±0.1
P1	Cavity to Perforation (Length Direction)	2±0.1
A0	Cavity Length	6.5±0.1
B0	Cavity Width	10.3±0.1
K0	Cavity Depth	2.1±0.1
t	Carrier Tape Thickness	0.3±0.05
C	Cover Tape Width	13.3

SOP 18W

Symbol	Description	Dimensions in mm
W	Carrier Tape Width	24.0+0.3 -0.1
P	Cavity Pitch	16.0±0.1
E	Perforation Position	1.75±0.1
F	Cavity to Perforation (Width Direction)	11.5±0.1
D	Perforation Diameter	1.5±0.1
D1	Cavity Hole Diameter	1.5±0.25
P0	Perforation Pitch	4.0±0.1
P1	Cavity to Perforation (Length Direction)	2.0±0.1
A0	Cavity Length	10.9±0.1
B0	Cavity Width	12.0±0.1
K0	Cavity Depth	2.8±0.1
t	Carrier Tape Thickness	0.3±0.05
C	Cover Tape Width	21.3

SSOP 20S (150mil)

Symbol	Description	Dimensions in mm
W	Carrier Tape Width	16+0.3 -0.1
P	Cavity Pitch	8±0.1
E	Perforation Position	1.75±0.1
F	Cavity to Perforation (Width Direction)	7.5±0.1
D	Perforation Diameter	1.5+0.1
D1	Cavity Hole Diameter	1.5+0.25
P0	Perforation Pitch	4±0.1
P1	Cavity to Perforation (Length Direction)	2±0.1
A0	Cavity Length	6.5±0.1
B0	Cavity Width	9±0.1
K0	Cavity Depth	2.3±0.1
t	Carrier Tape Thickness	0.3±0.05
C	Cover Tape Width	13.3

SOP 24W

Symbol	Description	Dimensions in mm
W	Carrier Tape Width	24±0.3
P	Cavity Pitch	12±0.1
E	Perforation Position	1.75±0.1
F	Cavity to Perforation (Width Direction)	11.5±0.1
D	Perforation Diameter	1.55+0.1
D1	Cavity Hole Diameter	1.5+0.25
P0	Perforation Pitch	4±0.1
P1	Cavity to Perforation (Length Direction)	2±0.1
A0	Cavity Length	10.9±0.1
B0	Cavity Width	15.9±0.1
K0	Cavity Depth	3.1±0.1
t	Carrier Tape Thickness	0.35±0.05
C	Cover Tape Width	21.3

SSOP 24S (150mil)

Symbol	Description	Dimensions in mm
W	Carrier Tape Width	16+0.3 -0.1
P	Cavity Pitch	8±0.1
E	Perforation Position	1.75±0.1
F	Cavity to Perforation (Width Direction)	7.5±0.1
D	Perforation Diameter	1.5+0.1
D1	Cavity Hole Diameter	1.5+0.25
P0	Perforation Pitch	4±0.1
P1	Cavity to Perforation (Length Direction)	2±0.1
A0	Cavity Length	6.5±0.1
B0	Cavity Width	9.5±0.1
K0	Cavity Depth	2.1±0.1
t	Carrier Tape Thickness	0.3±0.05
C	Cover Tape Width	13.3

SOP 28W (300mil)

Symbol	Description	Dimensions in mm
W	Carrier Tape Width	24±0.3
P	Cavity Pitch	12±0.1
E	Perforation Position	1.75±0.1
F	Cavity to Perforation (Width Direction)	11.5±0.1
D	Perforation Diameter	1.5+0.1
D1	Cavity Hole Diameter	1.5+0.25
P0	Perforation Pitch	4±0.1
P1	Cavity to Perforation (Length Direction)	2±0.1
A0	Cavity Length	10.85±0.1
B0	Cavity Width	18.34±0.1
K0	Cavity Depth	2.97±0.1
t	Carrier Tape Thickness	0.35±0.01
C	Cover Tape Width	21.3

SSOP 28S (150mil)

Symbol	Description	Dimensions in mm
W	Carrier Tape Width	16±0.3
P	Cavity Pitch	8±0.1
E	Perforation Position	1.75±0.1
F	Cavity to Perforation (Width Direction)	7.5±0.1
D	Perforation Diameter	1.55±0.1
D1	Cavity Hole Diameter	1.5±0.25
P0	Perforation Pitch	4±0.1
P1	Cavity to Perforation (Length Direction)	2±0.1
A0	Cavity Length	6.5±0.1
B0	Cavity Width	10.3±0.1
K0	Cavity Depth	2.1±0.1
t	Carrier Tape Thickness	0.3±0.05
C	Cover Tape Width	13.3

Holtek Semiconductor Inc. (Headquarters)

No.3, Creation Rd. II, Science Park, Hsinchu, Taiwan
Tel: 886-3-563-1999
Fax: 886-3-563-1189
<http://www.holtek.com.tw>

Holtek Semiconductor Inc. (Taipei Sales Office)

4F-2, No. 3-2, YuanQu St., Nankang Software Park, Taipei 115, Taiwan
Tel: 886-2-2655-7070
Fax: 886-2-2655-7373
Fax: 886-2-2655-7383 (International sales hotline)

Holtek Semiconductor Inc. (Shanghai Sales Office)

7th Floor, Building 2, No.889, Yi Shan Rd., Shanghai, China 200233
Tel: 86-21-6485-5560
Fax: 86-21-6485-0313
<http://www.holtek.com.cn>

Holtek Semiconductor Inc. (Shenzhen Sales Office)

5F, Unit A, Productivity Building, Gaoxin M 2nd, Middle Zone Of High-Tech Industrial Park, ShenZhen, China 518057
Tel: 86-755-8616-9908, 86-755-8616-9308
Fax: 86-755-8616-9722

Holtek Semiconductor Inc. (Beijing Sales Office)

Suite 1721, Jinyu Tower, A129 West Xuan Wu Men Street, Xicheng District, Beijing, China 100031
Tel: 86-10-6641-0030, 86-10-6641-7751, 86-10-6641-7752
Fax: 86-10-6641-0125

Holtek Semiconductor Inc. (Chengdu Sales Office)

709, Building 3, Champagne Plaza, No.97 Dongda Street, Chengdu, Sichuan, China 610016
Tel: 86-28-6653-6590
Fax: 86-28-6653-6591

Holtek Semiconductor (USA), Inc. (North America Sales Office)

46729 Fremont Blvd., Fremont, CA 94538
Tel: 1-510-252-9880
Fax: 1-510-252-9885
<http://www.holtek.com>

Copyright © 2008 by HOLTEK SEMICONDUCTOR INC.

The information appearing in this Data Sheet is believed to be accurate at the time of publication. However, Holtek assumes no responsibility arising from the use of the specifications described. The applications mentioned herein are used solely for the purpose of illustration and Holtek makes no warranty or representation that such applications will be suitable without further modification, nor recommends the use of its products for application that may present a risk to human life due to malfunction or otherwise. Holtek's products are not authorized for use as critical components in life support devices or systems. Holtek reserves the right to alter its products without prior notification. For the most up-to-date information, please visit our web site at <http://www.holtek.com.tw>.