

AN7289NSC

FM-FE+AM IC for car radio

Overview

The AN7289NSC is an IC having FM-FE+AM functions for car radio. A tuner block of car radio can be constructed by combination of this IC and the AN7293NSC / NFBQ.

Features

- A less number of electrolytic capacitors is required (3 capacitors reduction compared with our conventional IC)
- AM: Practical sensitivity is improved by 2 dB by ATC
- AM: Strong input characteristics is improved by 2-loop AGC function

Applications

- Car radios

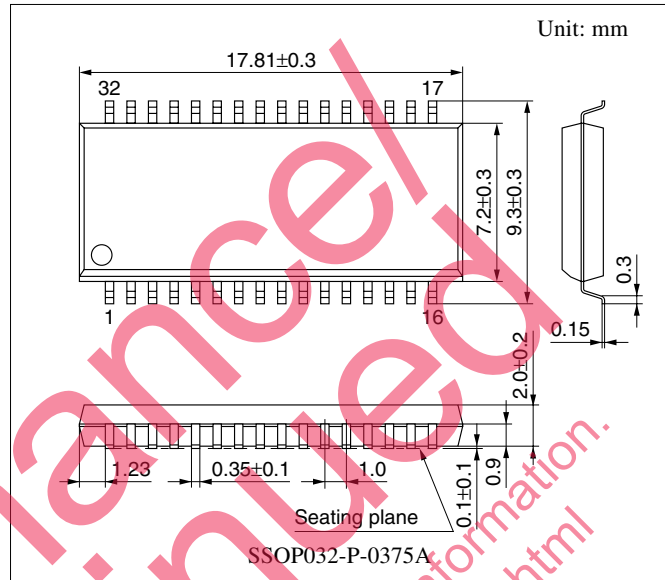

Note) The package of this product will be changed to lead-free type (SSOP032-P-0375C). See the new package dimensions section later of this datasheet.

Block Diagram

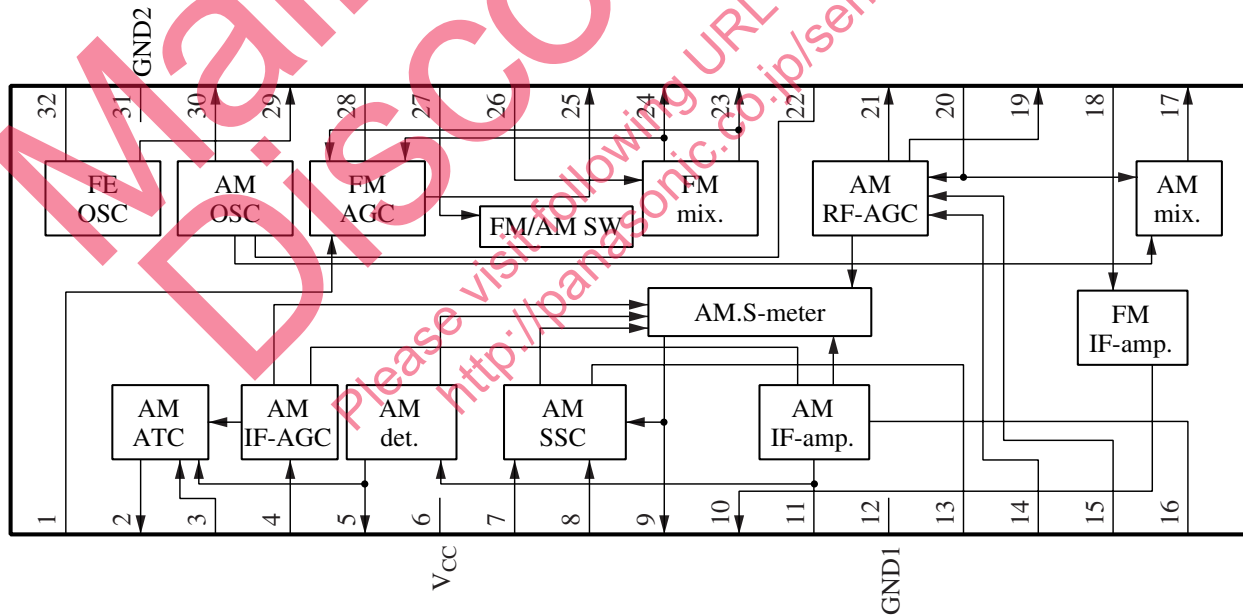

■ Pin Description

Pin No.	Description	Pin No.	Description
1	FM-keyed-AGC input	18	FM-IF input
2	AM-AF output / LO setting	19	AM-RF gain control
3	AM-ATC input	20	AM-mix. input
4	AM-IF level detection	21	FM-PIN-diode driver
5	AM detection output	22	AM-OSC coil pin
6	V _{CC1}	23	FM-mix. output (2)
7	AM-IF counter output / DX / LO SW	24	FM-mix. output (1)
8	AM-SD output	25	FM-PIN-diode driver
9	AM-signal meter output	26	FM-mix. input
10	FM-IF output	27	V _{CC2} / FM / AM SW
11	AM-IF output	28	FM-AGC output
12	GND1	29	FM-OSC buffer output
13	SSC	30	AM-OSC buffer output / FE-AGC sensitivity setting
14	AM-RF level detection	31	GND2
15	AM-WAGC detection / DX setting	32	FM-OSC coil pin
16	AM-IF input		
17	AM-mix. output		

■ Absolute Maximum Ratings

Parameter	Symbol	Rating	Unit
Supply voltage	V _{CC}	9.1	V
Supply current	I _{CC}	56	mA
Power dissipation *2	P _D	380.2	mW
Operating ambient temperature *1	T _{opr}	-35 to +80	°C
Storage temperature *1	T _{stg}	-55 to +125	°C

Note) *1: Except for the power dissipation, operating ambient temperature, and storage temperature, all ratings are for T_a = 25°C.

*2: T_a = 80°C

■ Recommended Operating Range

Parameter	Symbol	Range	Unit
Supply voltage	V _{CC}	7.2 to 9.0	V

■ Electrical Characteristics at $T_a = 25^\circ\text{C}$

1. AM mode $V_{CC} = 8.0\text{ V}$, $f_{IN} = 1\text{ MHz}$

AM tuning condition: OSC output frequency = 1 450 kHz \pm 500 Hz

Parameter	Symbol	Conditions	Min	Typ	Max	Unit
AM consumption current	amI _{t1}	Without input	28	36	44	mA
AM-AF output	amV _O	AM-AF output at $V_{IN2} = 74\text{ dB}\mu$, 400 Hz 30%	100	125	155	mA
AM signal-to-noise ratio	amSN	AM-AF output S/N at $V_{IN2} = 74\text{ dB}\mu$, 400 Hz 30%	48	52	58	dB
AM-AGC width	amW	AM-AF output when input changes -10 dB at $V_{IN2} = 74\text{ dB}\mu$, 400 Hz 30%	55	59	63	dB
AM-ATC operation	amATC	(Output ratio [dB] of 400 Hz and 3 kHz when $V_{IN2} = 18\text{ dB}\mu$) - (Output ratio [dB] of 400 Hz and 3 kHz when $V_{IN2} = 74\text{ dB}\mu$) 80% Mod., AM-AF Out output	3.5	6.5	9.5	dB
AM-distortion 1	amT ₁	$V_{IN2} = 74\text{ dB}\mu$ 400 Hz 80% AM-AF output distortion	0.01	0.5	1.5	%
AM-distortion 2	amT ₂	$V_{IN2} = 130\text{ dB}\mu$ 400 Hz 80% AM-AF output distortion	0.01	0.5	1.5	%
AM wide band AGC on input	amV _w	$f_{IN2} = 1.4\text{ MHz}$ Input when pin 15 voltage becomes below 3 V	97	103	109	dB μ
AM local oscillation buffer output	amV _{OS}	Without input	160	210	260	mV
AM-IF count output 1	amIF ₁	$V_{IN2} = 40\text{ dB}\mu$	150	210	270	mV
AM-IF count output 2	amIF ₂	Without input	—	—	10	mV
AM-SD output 1	amSD ₁	$V_{IN2} = 40\text{ dB}\mu$	4.5	4.9	5.1	V
AM-SD output 2	amSD ₂	Without input	0.0	0.2	0.5	V
AM signal meter output 1	amV _{S1}	Without input, pin 9 voltage	1	50	200	mV
AM signal meter output 2	amV _{S2}	Pin 9 voltage at $V_{IN2} = 30\text{ dB}\mu$	0.7	0.95	1.2	V
AM signal meter output 3	amV _{S3}	Pin 9 voltage at $V_{IN2} = 130\text{ dB}\mu$	4.1	4.8	5.1	V
AM search sensitivity DX	amDX	AM-IF count output is 120 mV or over V_{IN2} when f becomes 450 kHz \pm 2 kHz	24	30	36	dB μ
AM search sensitivity LO	amLO	AM-IF count output is 120 mV or over V_{IN2} when f becomes 450 kHz \pm 2 kHz	44	50	56	dB μ

■ Electrical Characteristics at $T_a = 25^\circ\text{C}$ (continued)

2. FM mode $V_{CC} = 8.0\text{ V}$, $f_{IN1} = 98\text{ MHz}$

FM tuning condition: OSC output frequency = $108.7\text{ MHz} \pm 10\text{ kHz}$

Parameter	Symbol	Conditions	Min	Typ	Max	Unit
FM local oscillation buffer output	fmV _{OS}	$f_{OSC} = 108.7\text{ MHz}$ without input	140	200	260	mV
FM-IF output level	fmIF	$V_{IN1} = 71\text{ dB}\mu$	50	95	140	mV
FM-AGC sensitivity	fmAGC	V_{IN1} level when V_{28} becomes 3 V	59	63	67	dB μ
FM-AGC voltage (high)	fmV _{aH}	$V_{IN1} = 70\text{ dB}\mu$ V_{28}	6.0	6.4	6.8	V
FM-AGC voltage (low)	fmV _{aL}	$V_{IN1} = 82\text{ dB}\mu$ V_{28}	—	0.05	0.5	V
FM consumption current	fmI _t	Without input	26	35	44	mA

■ Application Circuit Example

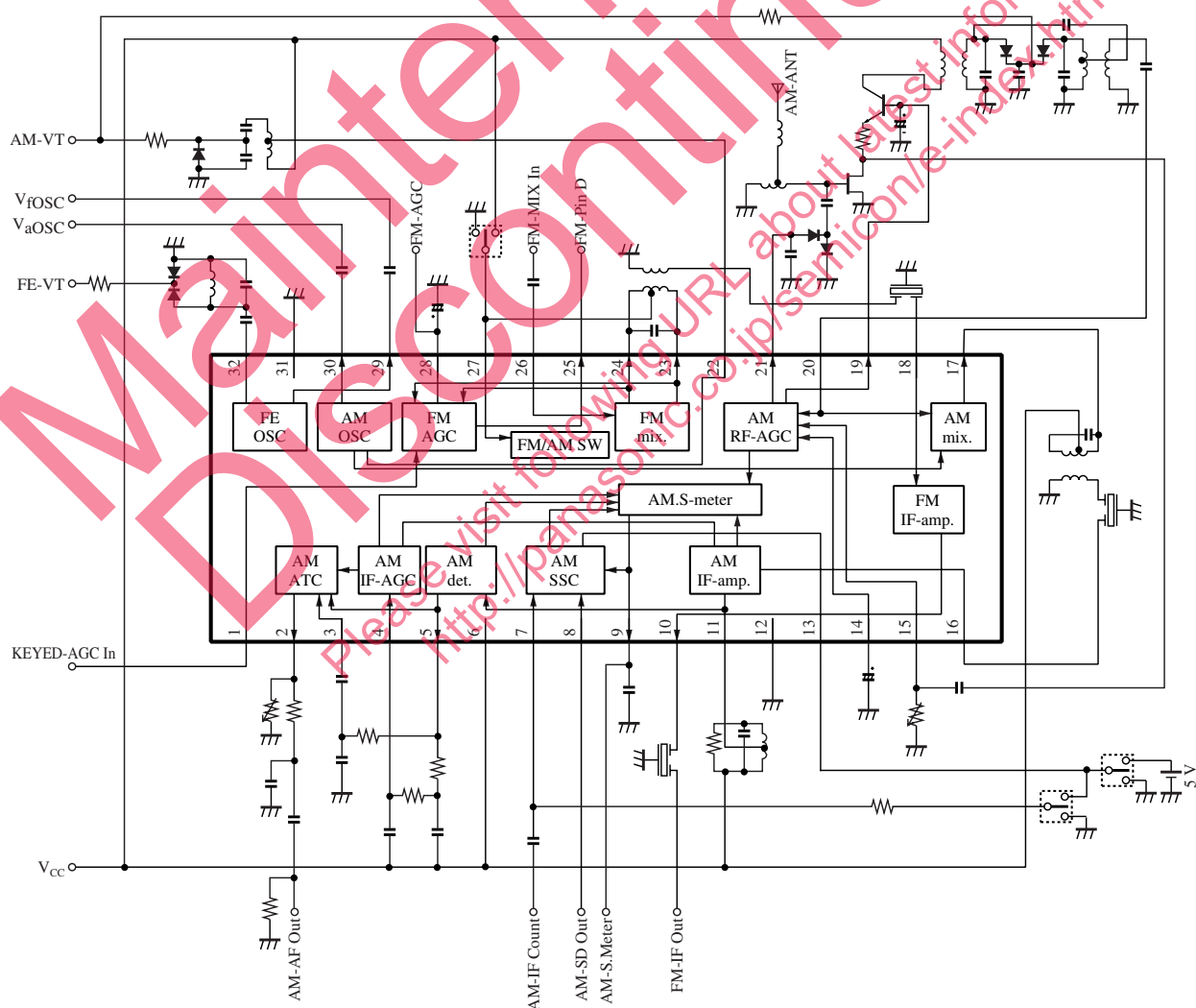

- New Package Dimensions (Unit: mm)
- SSOP032-P-0375C (Lead-free package)

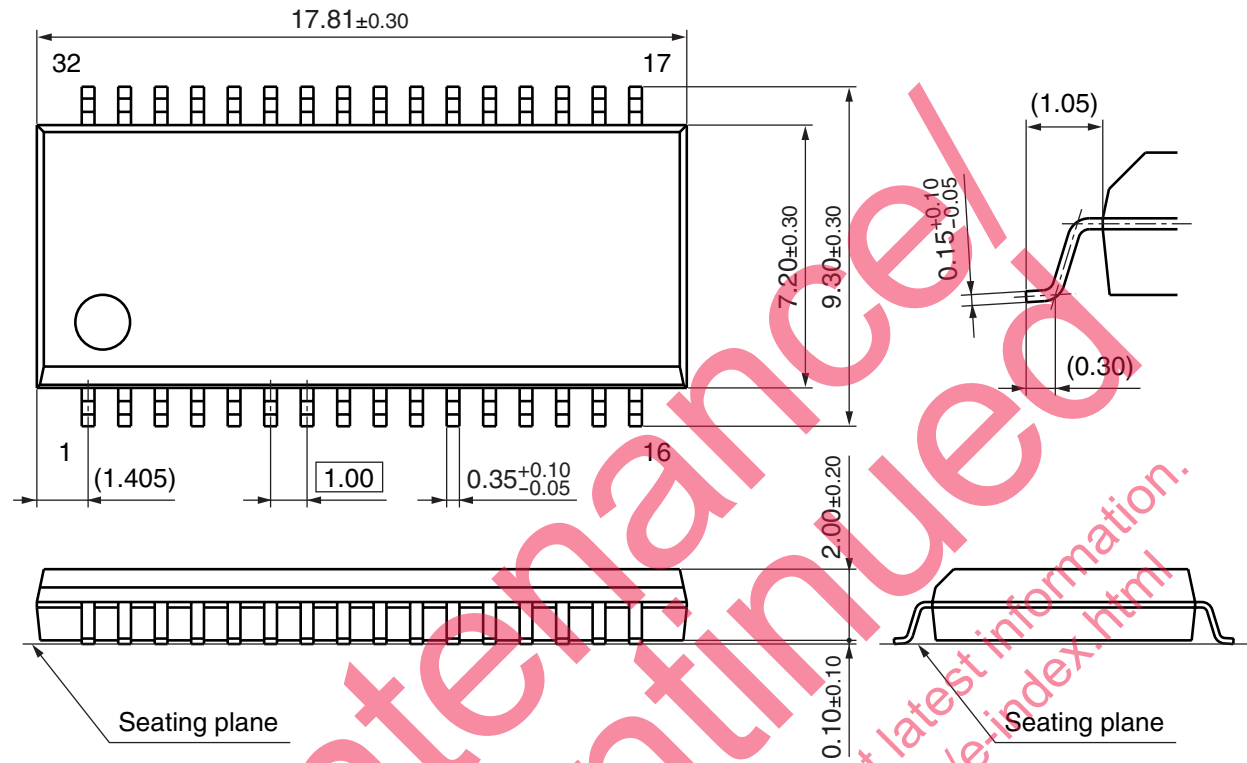

Maintenanced
Discontinued

Please visit following URL about latest information.
<http://panasonic.co.jp/semicon/e/index.html>

Request for your special attention and precautions in using the technical information and semiconductors described in this book

- (1) If any of the products or technical information described in this book is to be exported or provided to non-residents, the laws and regulations of the exporting country, especially, those with regard to security export control, must be observed.
- (2) The technical information described in this book is intended only to show the main characteristics and application circuit examples of the products, and no license is granted under any intellectual property right or other right owned by our company or any other company. Therefore, no responsibility is assumed by our company as to the infringement upon any such right owned by any other company which may arise as a result of the use of technical information described in this book.
- (3) The products described in this book are intended to be used for standard applications or general electronic equipment (such as office equipment, communications equipment, measuring instruments and household appliances).
Consult our sales staff in advance for information on the following applications:
 - Special applications (such as for airplanes, aerospace, automobiles, traffic control equipment, combustion equipment, life support systems and safety devices) in which exceptional quality and reliability are required, or if the failure or malfunction of the products may directly jeopardize life or harm the human body.
 - Any applications other than the standard applications intended.
- (4) The products and product specifications described in this book are subject to change without notice for modification and/or improvement. At the final stage of your design, purchasing, or use of the products, therefore, ask for the most up-to-date Product Standards in advance to make sure that the latest specifications satisfy your requirements.
- (5) When designing your equipment, comply with the range of absolute maximum rating and the guaranteed operating conditions (operating power supply voltage and operating environment etc.). Especially, please be careful not to exceed the range of absolute maximum rating on the transient state, such as power-on, power-off and mode-switching. Otherwise, we will not be liable for any defect which may arise later in your equipment.
 - Even when the products are used within the guaranteed values, take into the consideration of incidence of break down and failure mode, possible to occur to semiconductor products. Measures on the systems such as redundant design, arresting the spread of fire or preventing glitch are recommended in order to prevent physical injury, fire, social damages, for example, by using the products.
- (6) Comply with the instructions for use in order to prevent breakdown and characteristics change due to external factors (ESD, EOS, thermal stress and mechanical stress) at the time of handling, mounting or at customer's process. When using products for which damp-proof packing is required, satisfy the conditions, such as shelf life and the elapsed time since first opening the packages.
- (7) This book may be not reprinted or reproduced whether wholly or partially, without the prior written permission of Matsushita Electric Industrial Co., Ltd.