

AN6551

Dual Operational Amplifier

Overview

The AN6551 is a dual operational Amplifier with a phase compensation circuit built-in.

It is suitable for application to various electronic circuits such as active filters and audio pre-amplifiers.

Features

- Phase compensation circuit
- High gain, low noise
- Output short-circuit protection
- Two circuits symmetrically arranged in 9-pin SIL plastic package

Pin Descriptions

Pin No.	Pin name
2	Ch.1 output
3	Ch.1 inverting input
4	Ch.1 non inverting input
5	V _{EE} (GND)
6	Ch.2 non inverting input
7	Ch.2 inverting input
8	Ch.2 output
1, 9	V _{CC}

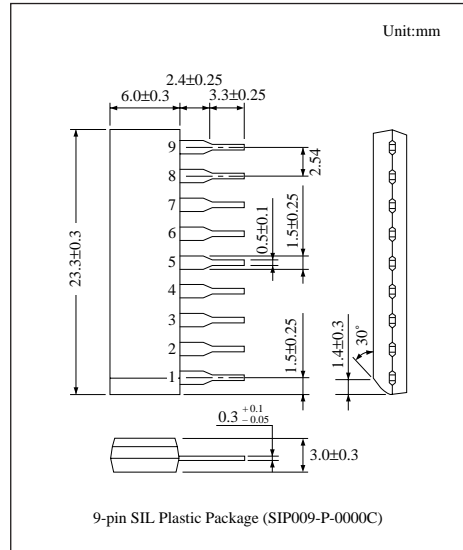

Block Diagram

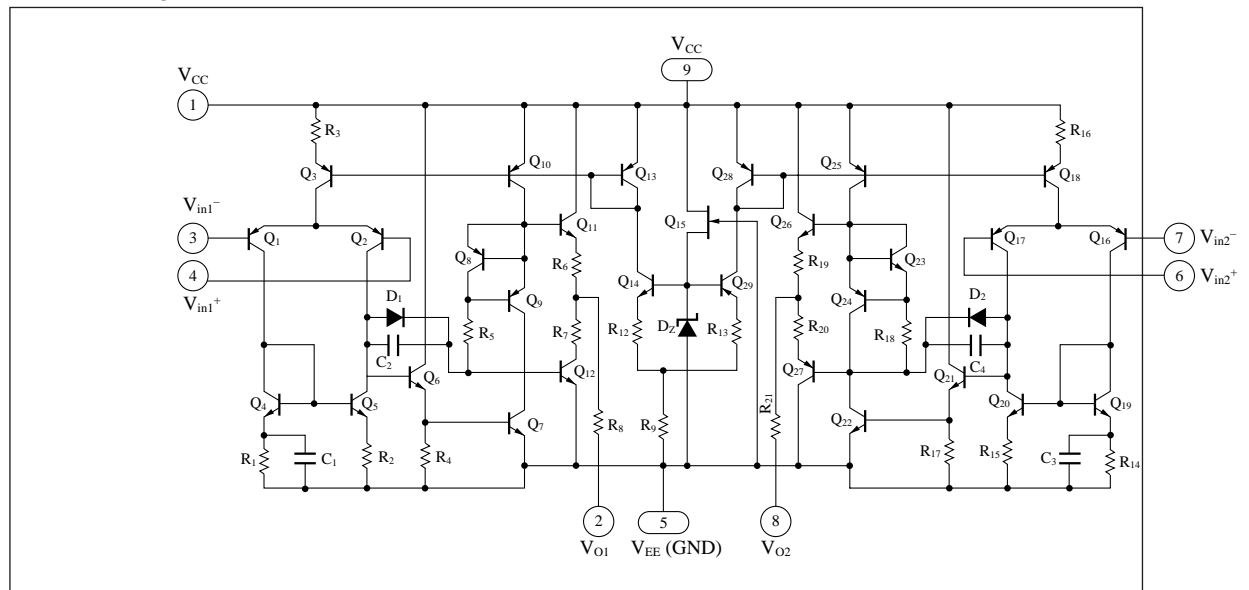

■ Absolute Maximum Ratings (Ta=25°C)

Parameter		Symbol	Rating	Unit
Voltage	Supply voltage	V_{CC}, V_{EE}	± 18	V
	Differential input voltage	V_{ID}	± 30	V
	Common-mode input voltage	V_{ICM}	± 15	V
Power dissipation		P_D	500	mW
Temperature	Operating ambient temperature	T_{opr}	-20 to +75	°C
	Storage temperature	T_{stg}	-55 to +150	°C

■ Electrical Characteristics (V_{CC}=15V, V_{EE}=-15V, Ta=25°C)

Parameter	Symbol	Condition	min	typ	max	Unit
Input offset voltage	$V_{I(offset)}$	$R_S \leq 10k\Omega$	—	0.5	6	mV
Input offset current	I_{IO}		—	5	200	nA
Input bias current	I_{bias}		—	—	500	nA
Voltage gain	G_V	$R_L \geq 2k\Omega, V_O = \pm 10V$	86	100	—	dB
Maximum output voltage	$V_{O(max)}$	$R_L \geq 10k\Omega$	± 12	± 14	—	V
		$R_L \geq 2k\Omega$	± 10	± 13	—	V
Common-mode input voltage width	V_{CM}		± 12	± 14	—	V
Common-mode rejection ratio	CMR		70	90	—	dB
Supply voltage rejection ratio	SVR		—	30	150	$\mu V/V$
Power consumption	P_C	$R_L = \infty$	—	90	170	mW
Slew rate	SR	$R_L \geq 2k\Omega$	—	1.0	—	V/ μs
Equivalent input noise voltage	V_{ni}	$R_S = 1k\Omega, B = 10Hz \text{ to } 30kHz$	—	2.5	—	μV_{rms}

■ Block Diagram

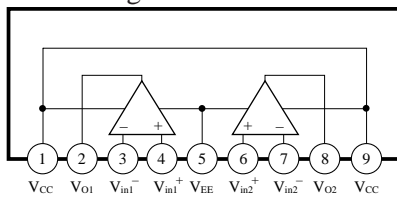

■ Characteristics Curve

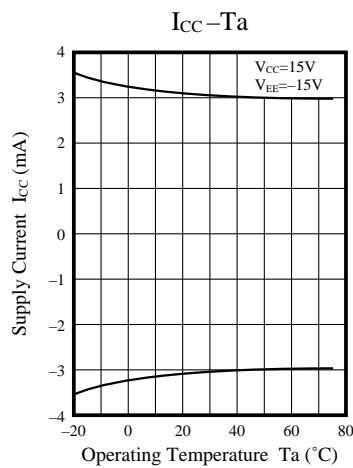
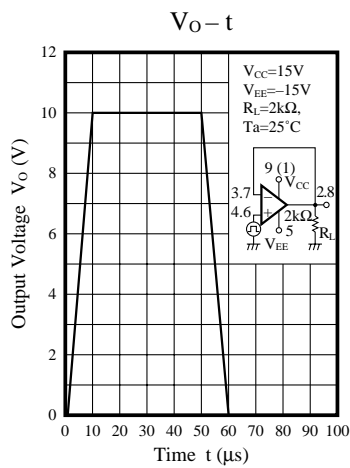
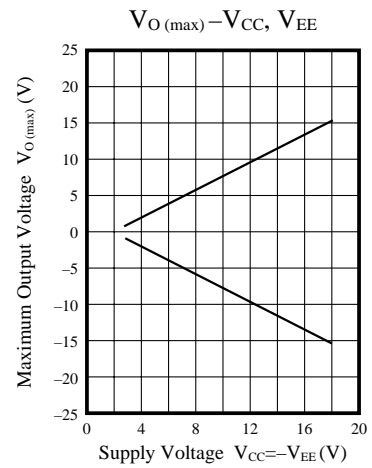
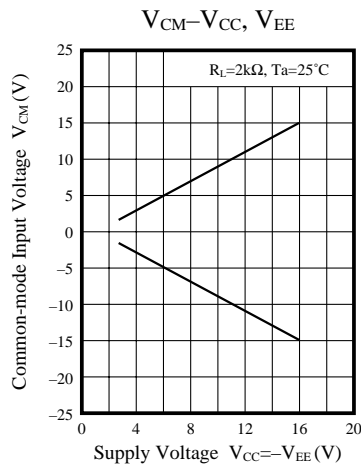
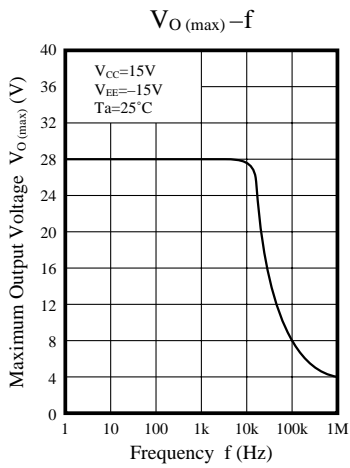
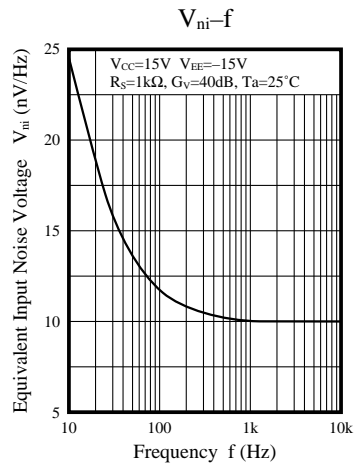
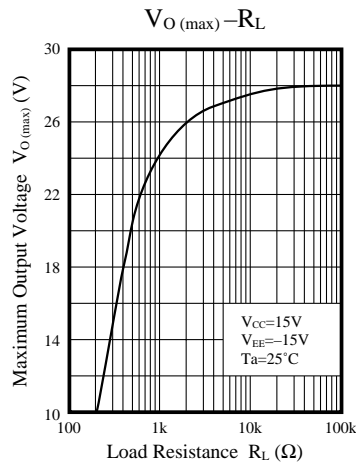
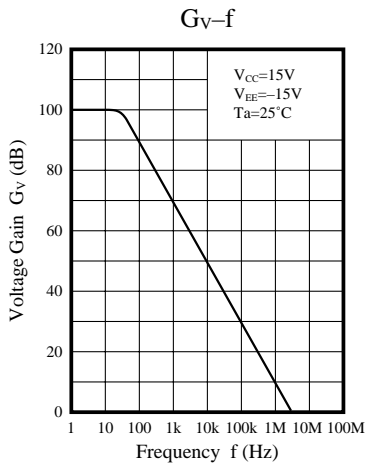

■ Application Circuit

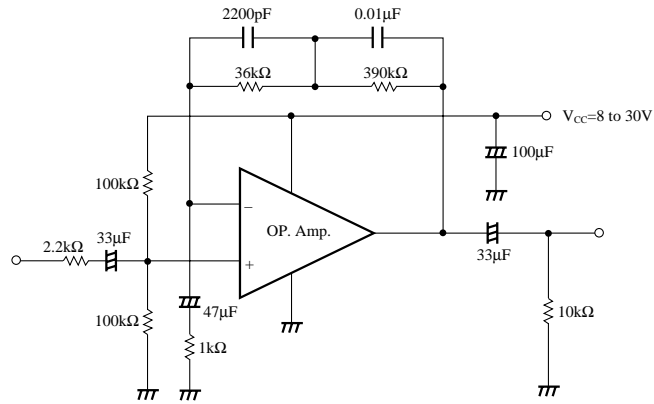

RIAA Pre-amp. (Single voltage operation)