

**LED Based L-864 Red Medium Intensity Beacon  
for Obstruction Applications**



## Certified to:

FAA AC NO: 150/5345-43F  
FAA Engineering Brief No. 67

## Qualified By:

Intertek ETL

## Compliant to:

ICAO Annex 14, 4th Edition, July 2004  
ICAO Aerodromes Design Manual, Chapter 18  
Canadian Aviation Regulation CAR 621.19  
(Transport Canada)

US Patent # 7,281,821  
Other Patents Pending

# LED Based L-864 Red Medium Intensity Beacon

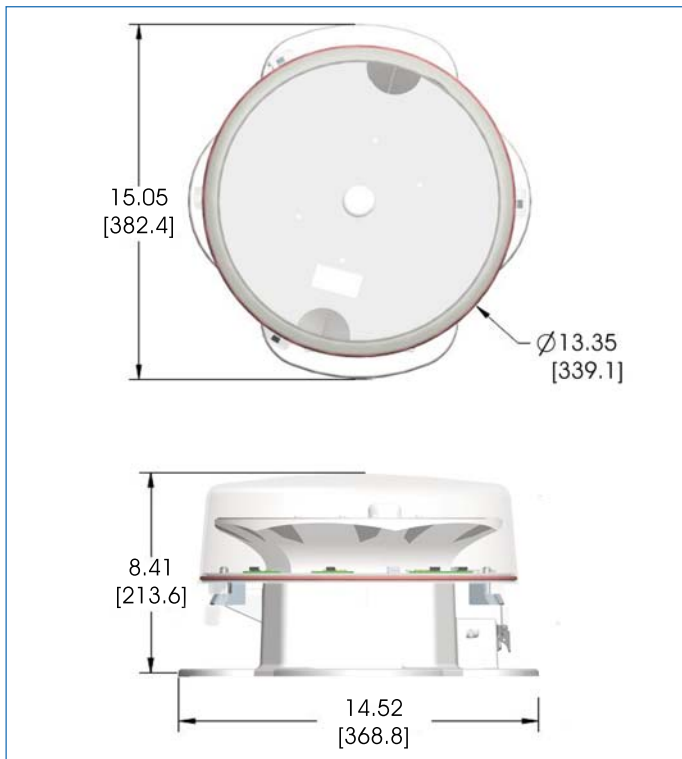

Dimensions in Inches [mm]

## Features & Benefits:

- ▷ Over 90% more efficient than incandescent
- ▷ Resistant to shock and vibration
- ▷ Lasts years longer than an incandescent
- ▷ \*Steady burn or Flashes (20-40fpm controller required)
- ▷ 5 year performance warranty
- ▷ FCC Testing EMC #47CFR,Part15:2008,Class A
- ▷ Easily adapts to older incandescent units
- \*FAA certified to 30 fpm

## Application:

The Dialight D464 Series LED based medium intensity red beacon utilizes state-of-the-art optical design to achieve the most compact, efficient, FAA compliant L864 device in the market. While it readily interfaces into existing installations, its robust, low power design will provide years of maintenance free service.

## Order codes:

D464-A13-001 Beacon	120 / 240 VAC FAA
D464-A13-001EU Beacon	120 / 240 VAC ICAO
D2643002	Retrofit Adapter

## Unit Weight:

20lbs (9Kg)

## Supply Voltage:

120-240 VAC Universal Input

## Watts:

20W

## Operating Temp:

-40°F to +131°F (-40°C to +55°C)

## Power Factor:

>0.9

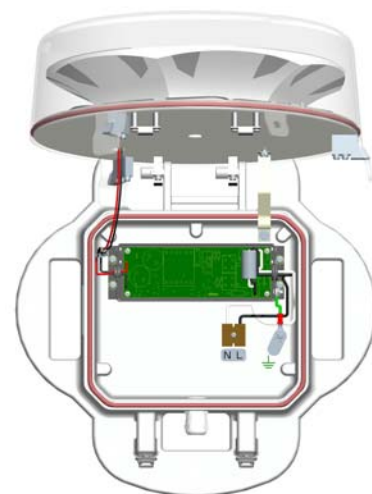

# LED Based L-864 Red Medium Intensity Beacon

FEATURES	BENEFITS
Industry's Longest Warranty	- <b>Complete performance 5 year warranty</b> (Xenon technology only 2 years)
All LED Flash Head = 10+ Years Life Expectancy	- <b>Long life and resistant to shock and vibration</b> Reduction in expensive tower climbs and maintenance costs / unplanned site visits
Uses State-of-the-Art High Flux LED Technology	- Replaces high maintenance, fragile incandescent bulbs and xenon tubes
20 Watt Power Consumption	- <b>Lowest power consumption L864 on the market</b> Saves energy and reduces cost
Very Precise Optics (Patented)	- <b>Minimum ground scatter light</b> Community friendly lighting system
Smallest Flash Head in the Industry, 8.41" high x 15.05" ø	- <b>Smallest on the market</b> Significantly less wind loading
Ease of Installation	- <b>Hinged lid to gaining access to terminal block</b>
IP66	- <b>Completely sealed from the outside environment</b>

## Dialight's LED Technology Innovations Over the Years



2000



2004



2006



2010

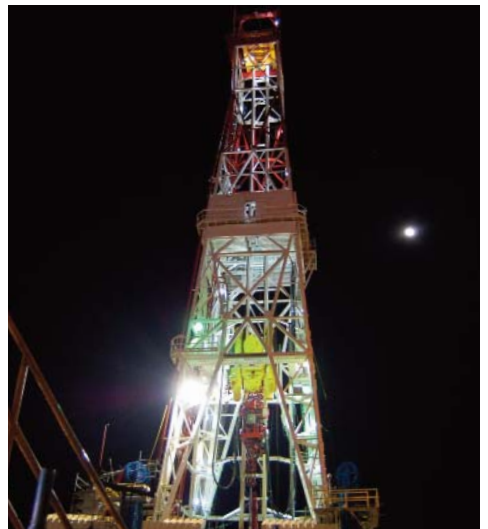

# Minimized Ground Scatter

## Sharp Beam Cutoff To Prevent Light Pollution

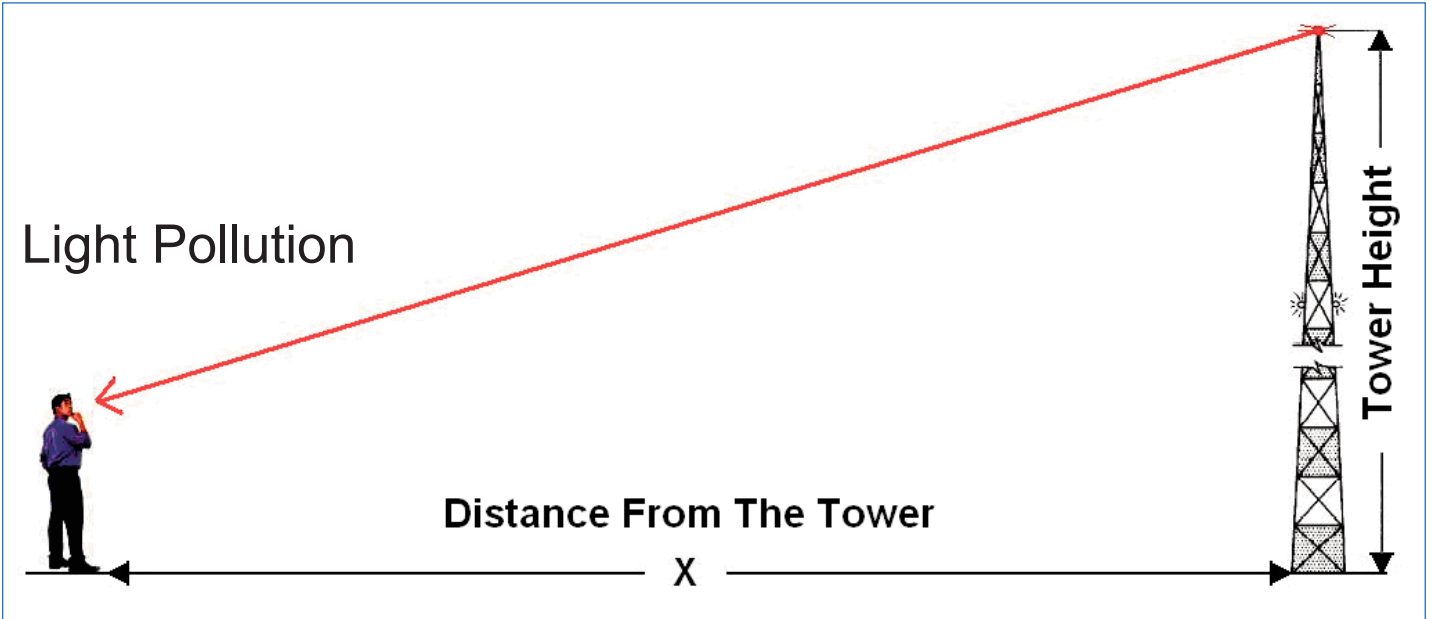

In lighting, it has always been a challenge to direct light where it is needed and cutoff light where it is not wanted. Over the years, flashing beacon lights that direct light downward into residential areas have caused numerous complaints and legal battles. This light pollution is caused primarily by limitations of the optical designs. Dialight has overcome this problem with a patented reflector based optics system designed specifically for the obstruction signals application. Dialight's optics technology creates the sharpest beam cutoff in the industry by directing almost no light downward.. The controlled beam pattern results in essentially zero light pollution. The chart below shows the light pollution (amount of light seen) at various distances for several 2,000 candela red beacons mounted on a 150-foot tower. The Dialight beacon maintains extremely low light levels to the ground while ensuring that aircraft see the required 2,000 candelas.

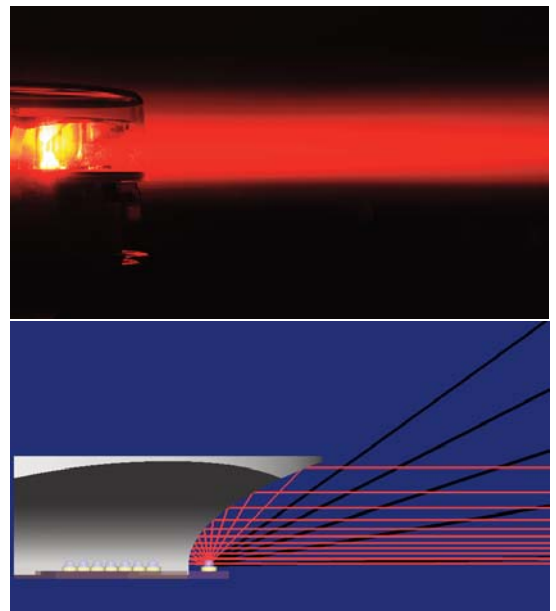
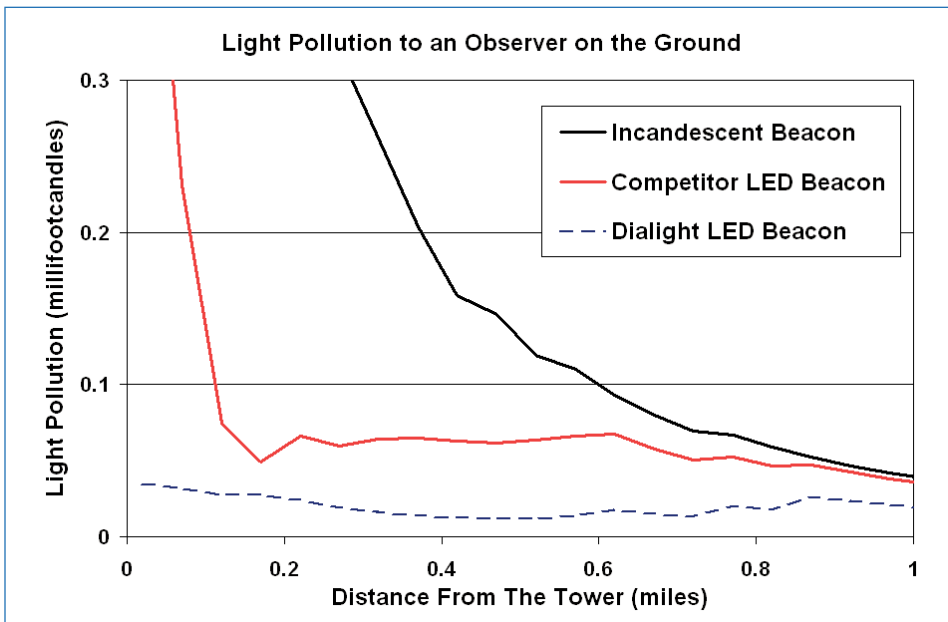

Dialight reserves the right to make changes at any time in order to supply the best product possible.

The most current version of this document will always be available at:

[http://www.dialight.com/Assets/Brochures\\_And\\_Catalogs/Signaling/MDTF464X001.pdf](http://www.dialight.com/Assets/Brochures_And_Catalogs/Signaling/MDTF464X001.pdf)

MDTF464X001\_A