

INTRODUCTION

Compondor is a composite word of compressor and expander. It is used for maintaining dynamic range and improving of S/N ratio, and generally called as a noise reduction system or automatic gain control system. KA8512 consists of compressor, expander, mic amp, limiter, ALC(automatic level control) and mute logic.

FEATURES

- Operating voltage range : 2 ~ 6V
- Included ALC circuit
- Easy gain control to use external component
- Included mute function

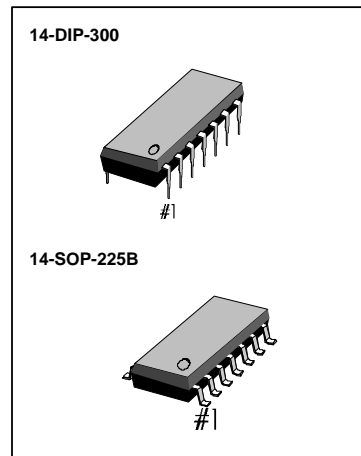

ORDERING INFORMATION

Device	Package	Operating Temperature
KA8512	14-DIP-300	-20°C ~ +70°C
KA8512D	14-SOP-225B	

BLOCK DIAGRAM

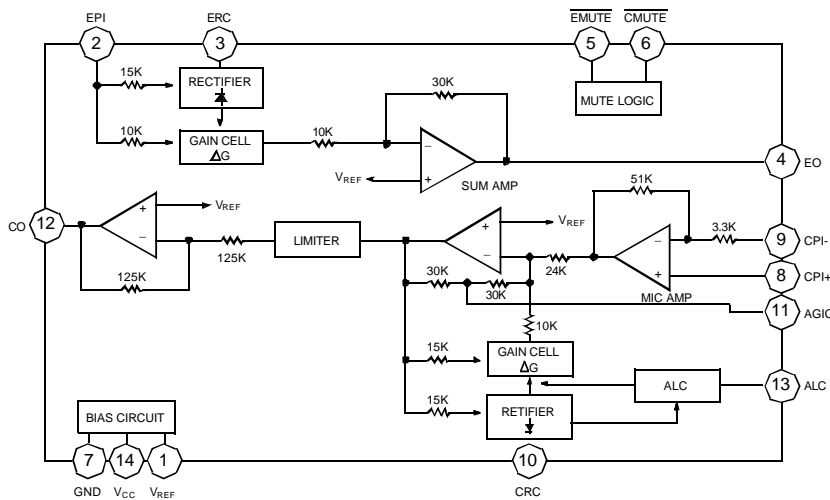

PIN CONFIGURATION

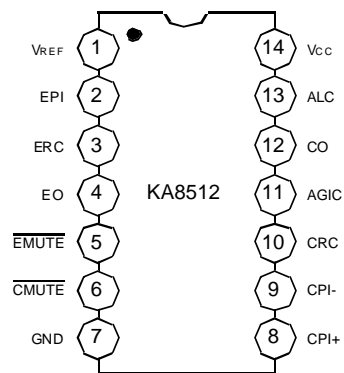

PIN DESCRIPTION

Pin No	Symbol	Description
1	V_{REF}	It is a voltage reference ($V_{REF}=1V$) used for supplying a constant voltage to the compressor and expander of compandor.
2	EPI	It is SUM AMP input terminal of expander. The voice signal recovered after the demodulation waveform from the receiver passed through the 2'nd order low pass filter enters this terminal.
3	ERC	This terminal is used for converting waveform from the full wave rectifier to DC element at the rectifier block of expander ($R \times C = 22msec$)
4	EO	It is an output terminal of expander, which a regenerated voice signal comes out.
5	\overline{EMUTE}	It is an expander mute terminal of compandor and the final mute block of an expander located next to the receiver terminal. It blocks the data signal of MICOM being transmitted to an user, and is connected to the RX mute terminal of MICOM. Expanding is executed if this terminal is high, and expander mute is executed if it is low.

PIN DESCRIPTION (Continued)

Pin No	Symbol	Description
6	$\overline{\text{CMUTE}}$	It is compressor mute terminal of a compandor. Mute block is used to avoid duplication of data transmission from MICOM (Between the base and hand set) with the voice signal. It is connected to the TX mute terminal of MICOM. Compressing is executed if the terminal is high, and compressor mute is executed if it is low.
7	GND	It is ground terminal.
8	CPI+	It is a MIC AMP non-inverting input terminal of compressor, and is used as an input terminal for voice signal.
9	CPI-	It is a MIC AMP inverting input terminal of compressor, and is used for adjusting the negative feedback loop gain. (In application, gain is about 5)
10	CRC	This terminal is used for converting waveform from the full wave rectifier to DC element at the rectifier block of compressor. (R X C = 22msec)
11	AGIC	This terminal is used for bypassing an AC element at the feed-back loop which comes from the SUM AMP block of compressor. A capacitor should be connected between this terminal and GND.
12	CO	It is a compressor output terminal of compandor, and is connected to the modulation input terminal of transmitter.
13	ALC	It is a reference voltage input terminal of ALC (Automatic Level Control). ALC circuit may be turned off according to the ALC reference voltage, magnitude of output voltage may be limited if it is used for adjusting THD of output voltage of compressor to less than 3% or to limit the frequency of TX in case the input is higher than a certain level.
14	V _{CC}	It is supply voltage terminal.



ABSOLUTE MAXIMUM RATINGS

Characteristic	Symbol	Value	Unit
Maximum Supply Voltage	$V_{CC(MAX)}$	7	V
Power Dissipation	P_D	600	mW
Operating Temperature	T_{OPR}	- 20 ~ + 70	°C
Storage Temperature	T_{STG}	- 55 ~ + 150	°C

ELECTRICAL CHARACTERISTICS

(V_{CC} = 3V, f = 1KHz, T_a = 25°C, Unless otherwise Specified)

Characteristic	Symbol	Test Conditions	Min	Typ	Max	Unit
DC Electrical Characteristics						
Operating Voltage	V_{CC}	-	2.0	-	6.0	V
Operating Current	I_{CC}	No Signal	-	3.6	6.0	mA
Compressor Part						
Reference Voltage	V_{REF}	No Signal	0.9	1.0	1.1	V
Standard Output Voltage	$V_{O(COMP)}$	$V_{INC} = 13mV_{rms}$ = 0dB	240	300	340	mV _{rms}
Gain Difference	$\Delta G_{V1(COMP)}$	$V_{INC} = -20dB$	-0.5	0	+0.5	dB
	$\Delta G_{V2(COMP)}$	$V_{INC} = -40dB$	-1.5	0.7	0	dB
Output Distortion	THD_{COMP}	$V_{INC} = 0dB$	-	0.5	1.0	%
Mute Attenuation Ratio	ATT_{MUTE}	$V_{INC} = 0dB$	60	80	-	dB
Limiting Voltage	$V_{LIM(COMP)}$	$V_{INC} = \text{Variable}$	1.15	1.35	1.5	V_{P-P}
ALC	V_{ALCO}	$V_{ALC} = 0.87V$	280	325	360	mV _{rms}
Expander Part						
Standard Output Voltage	$V_{O(EXP)}$	$V_{INE} = 180mV_{rms}$ = 0dB	110	130	160	mV _{rms}
Gain Difference	$\Delta G_{V1(EXP)}$	$V_{INE} = -10dB$	+1.0	+0.5	0	dB
	$\Delta G_{V2(EXP)}$	$V_{INE} = -20dB$	-1.5	-0.7	0	dB
	$\Delta G_{V3(EXP)}$	$V_{INE} = -30dB$	-1.5	0	+1.5	dB
Output Distortion	THD_{EXP}	$V_{INE} = 0dB$	-	0.5	1.5	%
Mute Attenuation Ratio	ATT_{MUTE}	$V_{INE} = 0dB$	60	85	-	dB
Maximum Output Voltage	$V_{O(EXP(MAX))}$	$V_{INE} = \text{Variable}$	500	600	-	mV _{rms}



TEST CIRCUIT

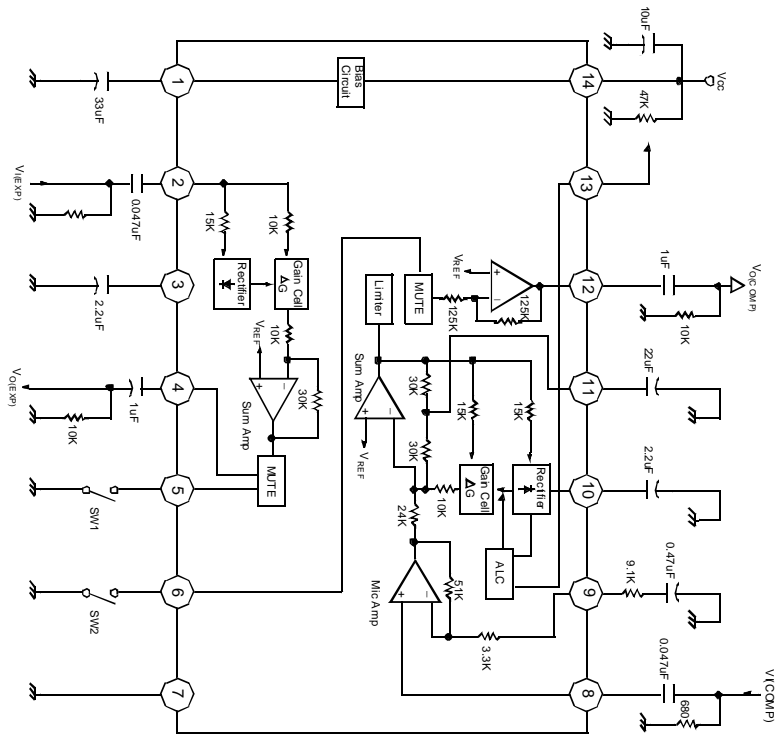

APPLICATION CIRCUIT

