



# STB11NK40Z, STP11NK40ZFP STP11NK40Z

N-channel 400 V, 0.49  $\Omega$ , 9 A, TO-220, TO-220FP, D<sup>2</sup>PAK  
Zener-protected SuperMESH™ Power MOSFET

## Features

Type	V <sub>DSS</sub>	R <sub>DS(on)</sub>	I <sub>D</sub>	P <sub>w</sub>
STB11NK40Z	400V	<0.55 $\Omega$	10A	110W
STP11NK40Z	400V	<0.55 $\Omega$	10A	110W
STP11NK40ZFP	400V	<0.55 $\Omega$	10A	30W

- Extremely high dv/dt capability
- 100% avalanche tested
- Gate charge minimized
- Very low intrinsic capacitances
- Very good manufacturing repeatability

## Applications

- Switching application

## Description

The SuperMESH™ series is obtained through an extreme optimization of ST's well established strip-based PowerMESH™ layout. In addition to pushing on-resistance significantly down, special care is taken to ensure a very good dv/dt capability for the most demanding applications.

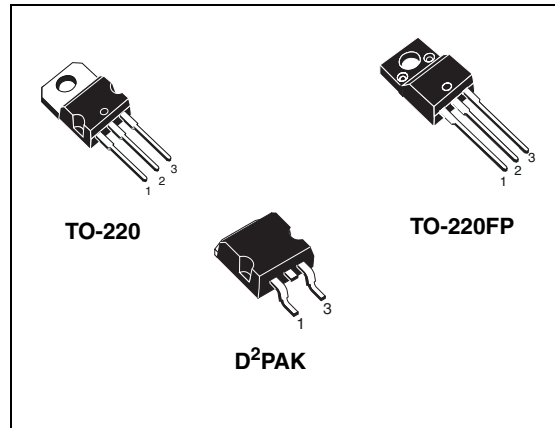

Figure 1. Internal schematic diagram

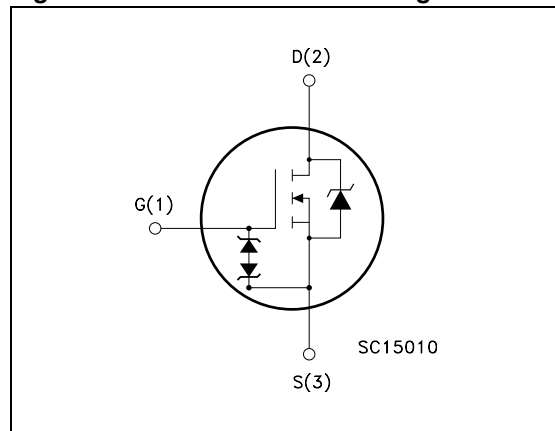

Table 1. Device summary

Order code	Marking	Package	Packaging
STB11NK40ZT4	B11NK40Z	D <sup>2</sup> PAK	Tape and reel
STP11NK40Z	P11NK40Z	TO-220	Tube
STP11NK40ZFP	P11NK40ZFP	TO-220FP	Tube

## Contents

<b>1</b>	<b>Electrical ratings</b> .....	<b>3</b>
<b>2</b>	<b>Electrical characteristics</b> .....	<b>5</b>
	2.1 Electrical characteristics (curves) .....	7
<b>3</b>	<b>Test circuits</b> .....	<b>10</b>
<b>4</b>	<b>Package mechanical data</b> .....	<b>11</b>
<b>5</b>	<b>Packaging mechanical data</b> .....	<b>15</b>
<b>6</b>	<b>Revision history</b> .....	<b>16</b>

# 1 Electrical ratings

**Table 2. Absolute maximum ratings**

Symbol	Parameter	Value		Unit
		TO-220/D <sup>2</sup> PAK	TO-220FP	
V <sub>DS</sub>	Drain-source voltage (V <sub>GS</sub> = 0)	400		V
V <sub>DGR</sub>	Drain-gate voltage (R <sub>GS</sub> = 20kΩ)	400		V
V <sub>GS</sub>	Gate-source voltage	± 30		V
I <sub>D</sub>	Drain current (continuous) at T <sub>C</sub> = 25°C	9	9 <sup>(1)</sup>	A
I <sub>D</sub>	Drain current (continuous) at T <sub>C</sub> = 100°C	5.67	5.67 <sup>(1)</sup>	A
I <sub>DM</sub> <sup>(2)</sup>	Drain current (pulsed)	36	36 <sup>(1)</sup>	A
P <sub>TOT</sub>	Total dissipation at T <sub>C</sub> = 25°C	110	30	W
	Derating factor	0.88	0.24	W/°C
V <sub>ESD(G-S)</sub>	Gate source ESD (HBM-C= 100pF, R= 1.5kΩ)	3500		V
dv/dt <sup>(3)</sup>	Peak diode recovery voltage slope	4.5		V/ns
V <sub>ISO</sub>	Insulation withstand voltage (DC)	--	2500	V
T <sub>J</sub> T <sub>stg</sub>	Operating junction temperature Storage temperature	-55 to 150		°C

- Limited only by maximum temperature allowed
- Pulse width limited by safe operating area
- I<sub>SD</sub> ≤ 9A, di/dt ≤ 200 A/μs, V<sub>DD</sub> ≤ V<sub>(BR)DSS</sub>, T<sub>J</sub> ≤ T<sub>JMAX</sub>.

**Table 3. Thermal data**

Symbol	Parameter	Value		Unit
		TO-220/D <sup>2</sup> PAK	TO-220FP	
R <sub>thj-case</sub>	Thermal resistance junction-case max	1.14	4.2	°C/W
R <sub>thj-a</sub>	Thermal resistance junction-ambient max	62.5		°C/W
T <sub>l</sub>	Maximum lead temperature for soldering purpose	300		°C

**Table 4. Avalanche characteristics**

Symbol	Parameter	Value	Unit
$I_{AR}$	Avalanche current, repetitive or not-repetitive (pulse width limited by $T_j$ max)	9	A
$E_{AS}$	Single pulse avalanche energy (starting $T_j=25^\circ\text{C}$ , $I_d=I_{AR}$ , $V_{DD}=50\text{V}$ )	190	mJ

## 2 Electrical characteristics

( $T_{CASE}=25^{\circ}C$  unless otherwise specified)

**Table 5. On/off states**

Symbol	Parameter	Test conditions	Min.	Typ.	Max.	Unit
$V_{(BR)DSS}$	Drain-source breakdown voltage	$I_D = 1mA, V_{GS} = 0$	400			V
$I_{DSS}$	Zero gate voltage drain current ( $V_{GS} = 0$ )	$V_{DS} = \text{Max rating},$ $V_{DS} = \text{Max rating} @ 125^{\circ}C$			1 50	$\mu A$ $\mu A$
$I_{GSS}$	Gate body leakage current ( $V_{DS} = 0$ )	$V_{GS} = \pm 20V, V_{DS} = 0$			$\pm 10$	$\mu A$
$V_{GS(th)}$	Gate threshold voltage	$V_{DS} = V_{GS}, I_D = 100\mu A$	3	3.75	4.5	V
$R_{DS(on)}$	Static drain-source on resistance	$V_{GS} = 10V, I_D = 4.5A$		0.49	0.55	$\Omega$

**Table 6. Dynamic**

Symbol	Parameter	Test conditions	Min.	Typ.	Max.	Unit
$g_{fs}^{(1)}$	Forward transconductance	$V_{DS} = 15V, I_D = 4.5A$	-	5.8	-	S
$C_{iss}$	Input capacitance	$V_{DS} = 25V, f = 1 \text{ MHz}, V_{GS} = 0$	-	930	-	pF
$C_{oss}$	Output capacitance			140		pF
$C_{rss}$	Reverse transfer capacitance			30		pF
$C_{oss \text{ eq}}^{(2)}$	Equivalent output capacitance	$V_{GS} = 0, V_{DS} = 0V \text{ to } 320V$	-	78	-	pF
$Q_g$	Total gate charge	$V_{DD} = 320V, I_D = 9A$	-	32	-	nC
$Q_{gs}$	Gate-source charge	$V_{GS} = 10V$		6		nC
$Q_{gd}$	Gate-drain charge	(see Figure 18)		18.5		nC

1. Pulsed: pulse duration=300 $\mu s$ , duty cycle 1.5%

2.  $C_{oss \text{ eq}}$  is defined as a constant equivalent capacitance giving the same charging time as  $C_{oss}$  when  $V_{DS}$  increases from 0 to 80%  $V_{DSS}$

**Table 7. Switching times**

Symbol	Parameter	Test conditions	Min.	Typ.	Max.	Unit
$t_{d(on)}$ $t_r$	Turn-on delay time Rise time	$V_{DD}=200\text{ V}$ , $I_D=4.5\text{ A}$ , $R_G=4.7\Omega$ , $V_{GS}=10\text{ V}$ (see Figure 20)	-	20 20	-	ns ns
$t_{d(off)}$ $t_f$	Turn-off delay time Fall time	$V_{DD}=200\text{ V}$ , $I_D=4.5\text{ A}$ , $R_G=4.7\Omega$ , $V_{GS}=10\text{ V}$ (see Figure 20)	-	40 18	-	ns ns
$t_{r(Voff)}$ $t_f$ $t_c$	Off-voltage rise time Fall time Cross-over time	$V_{DD}=320\text{ V}$ , $I_D=9\text{ A}$ , $R_G=4.7\Omega$ , $V_{GS}=10\text{ V}$ (see Figure 20)	-	15 17 30	-	ns ns ns

**Table 8. Source drain diode**

Symbol	Parameter	Test conditions	Min.	Typ.	Max.	Unit
$I_{SD}$	Source-drain current		-		9	A
$I_{SDM}^{(1)}$	Source-drain current (pulsed)		-		36	A
$V_{SD}^{(2)}$	Forward on voltage	$I_{SD}=9\text{ A}$ , $V_{GS}=0$	-		1.6	V
$t_{rr}$ $Q_{rr}$ $I_{RRM}$	Reverse recovery time Reverse recovery charge Reverse recovery current	$I_{SD}=9\text{ A}$ , $di/dt = 100\text{ A}/\mu\text{s}$ , $V_{DD}=45\text{ V}$ , $T_j=150^\circ\text{C}$	-	225 1.6 14		ns $\mu\text{C}$ A

1. Pulse width limited by safe operating area

2. Pulsed: pulse duration=300  $\mu\text{s}$ , duty cycle 1.5 %

**Table 9. Gate-source zener diode**

Symbol	Parameter	Test conditions	Min.	Typ.	Max.	Unit
$BV_{GSO}$	Gate-source breakdown voltage	$I_{gs}=\pm 1\text{ mA}$ (open drain)	30	-	-	V

The built-in back-to-back Zener diodes have specifically been designed to enhance not only the device's ESD capability, but also to make them safely absorb possible voltage transients that may occasionally be applied from gate to source. In this respect the Zener voltage is appropriate to achieve an efficient and cost-effective intervention to protect the device's integrity. These integrated Zener diodes thus avoid the usage of external components.

## 2.1 Electrical characteristics (curves)

Figure 2. Safe operating area for TO-220 D<sup>2</sup>PAK

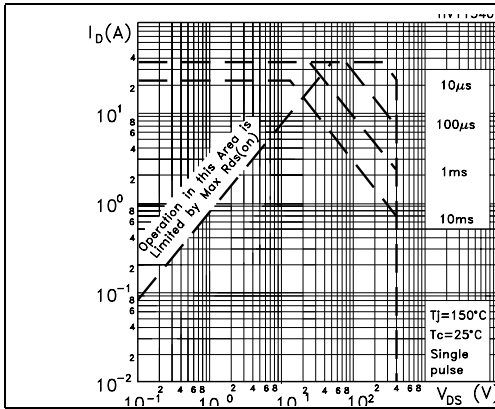

Figure 3. Thermal impedance for TO-220 D<sup>2</sup>PAK

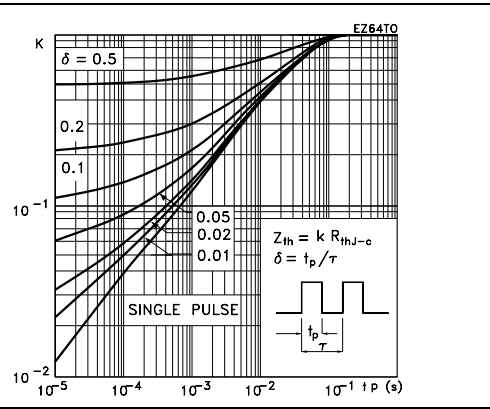

Figure 4. Safe operating area for TO-220FP

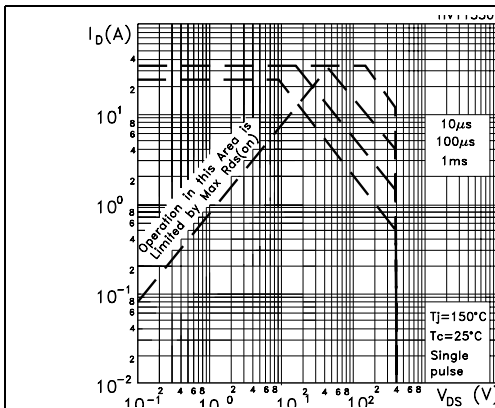

Figure 5. Thermal impedance for TO-220FP

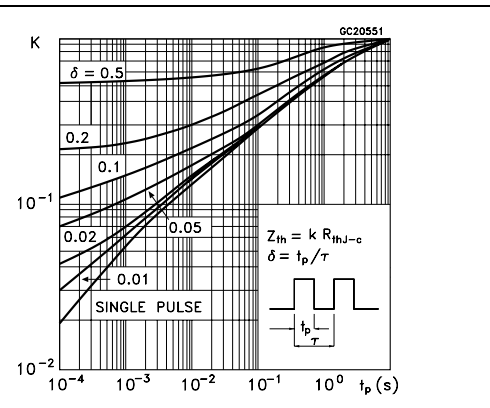

Figure 6. Output characteristics

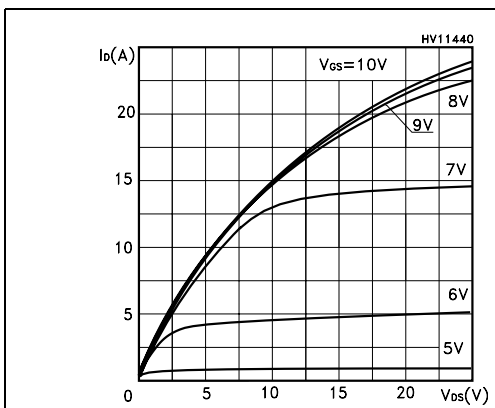

Figure 7. Transfer characteristics

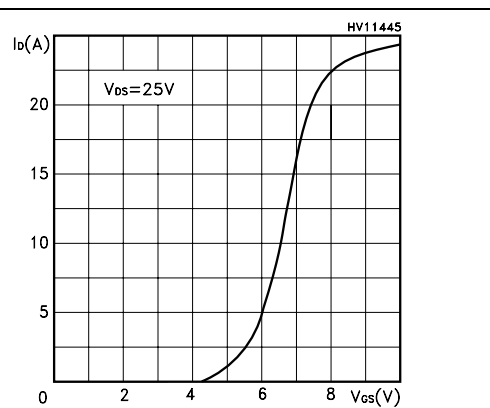

Figure 8. Transconductance

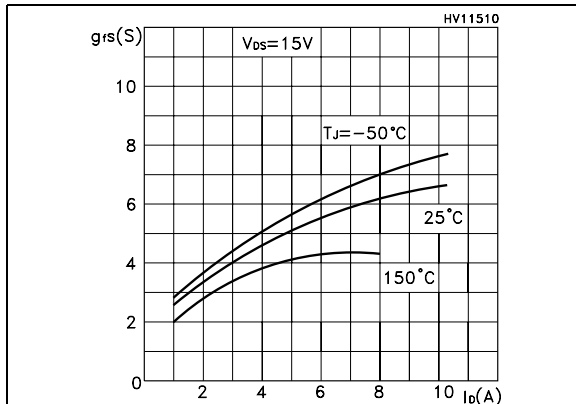

Figure 9. Static drain-source on resistance

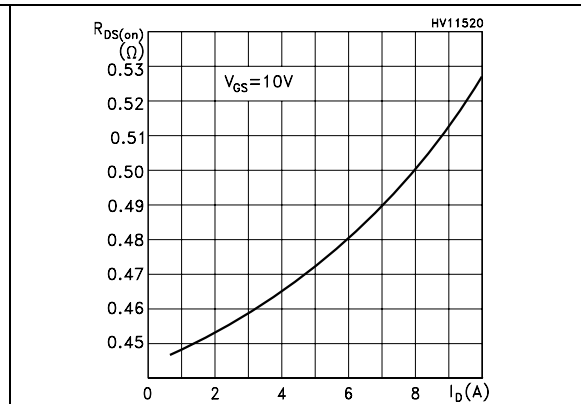

Figure 10. Gate charge vs gate-source voltage Figure 11. Capacitance variations

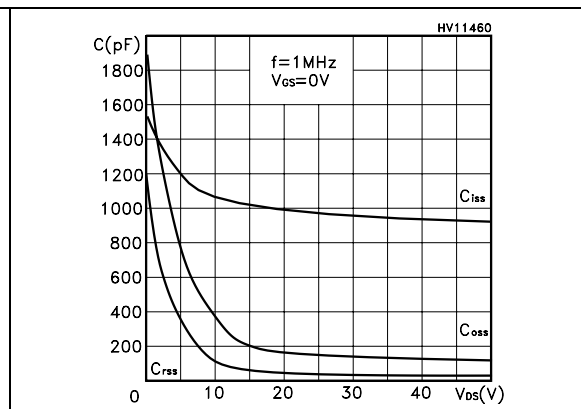
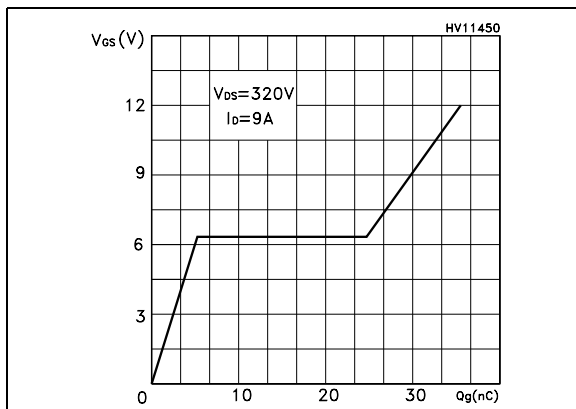

Figure 12. Normalized gate threshold voltage vs temperature

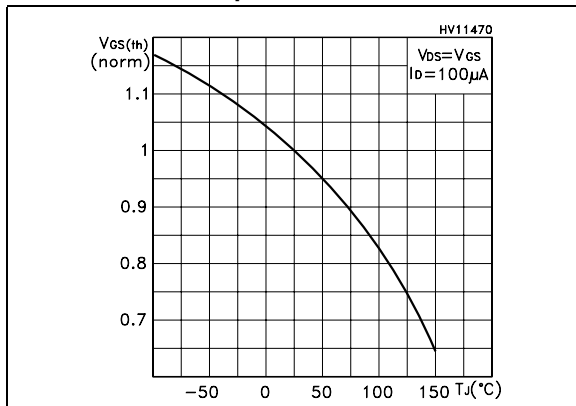

Figure 13. Normalized on resistance vs temperature

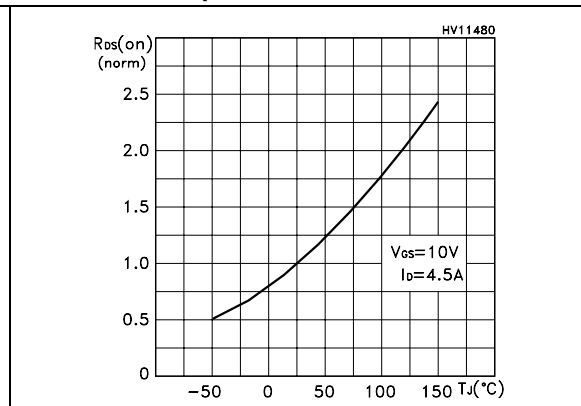



Figure 14. Source-drain diode forward characteristics

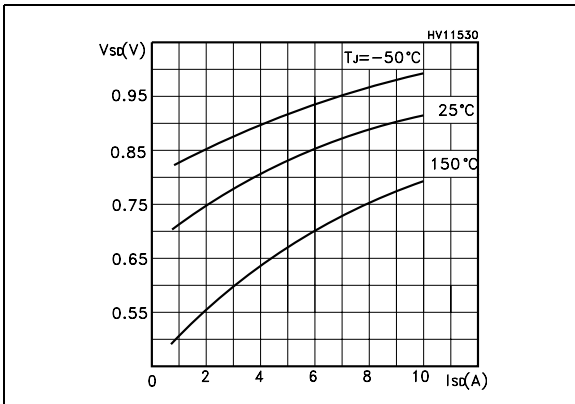

Figure 15. Normalized  $B_{VDSS}$  vs temperature

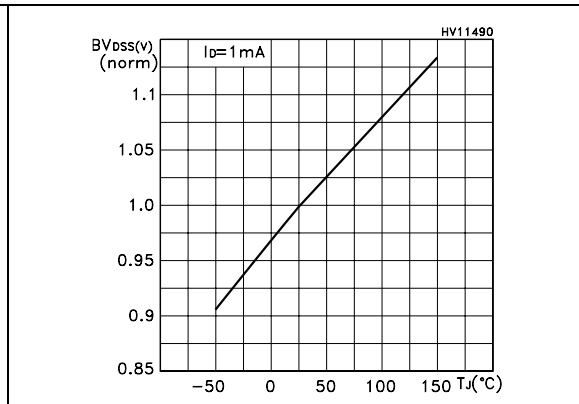
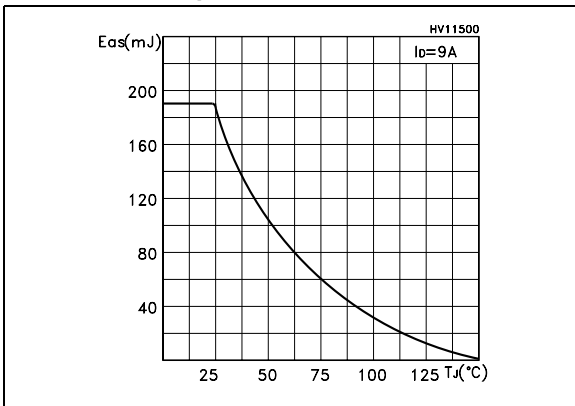

Figure 16. Maximum avalanche energy vs temperature



### 3 Test circuits

Figure 17. Switching times test circuit for resistive load

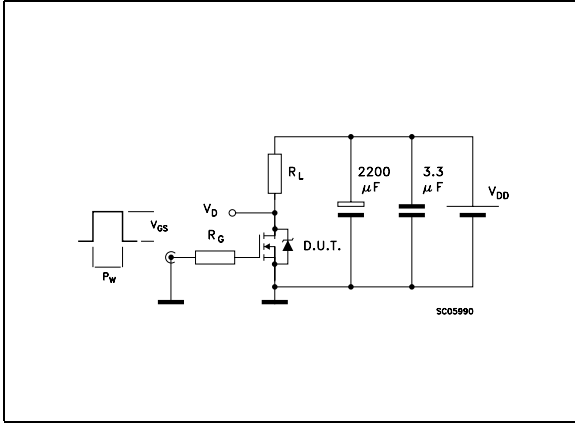

Figure 18. Gate charge test circuit

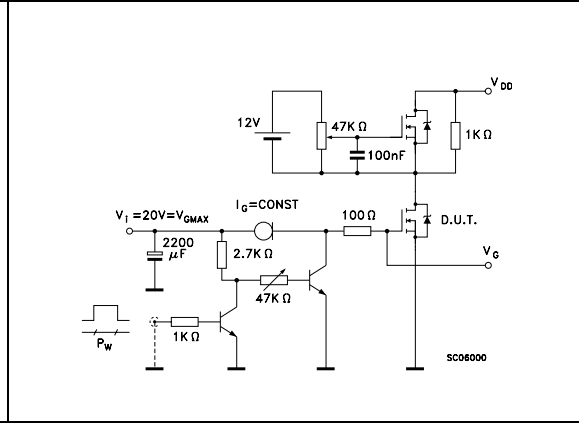

Figure 19. Test circuit for inductive load switching and diode recovery times

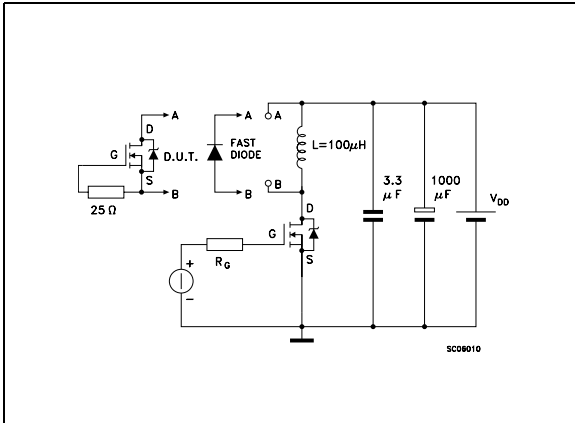

Figure 20. Unclamped inductive load test circuit

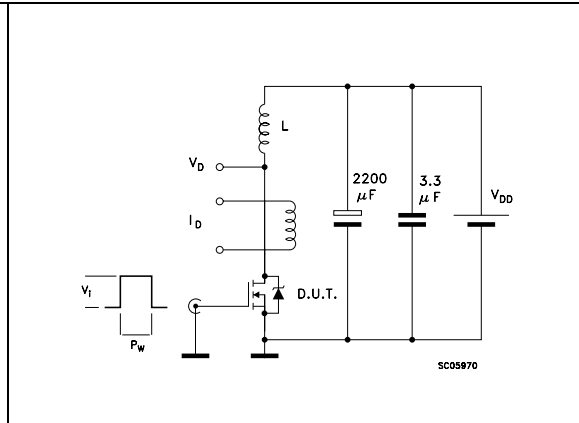

Figure 21. Unclamped inductive waveform

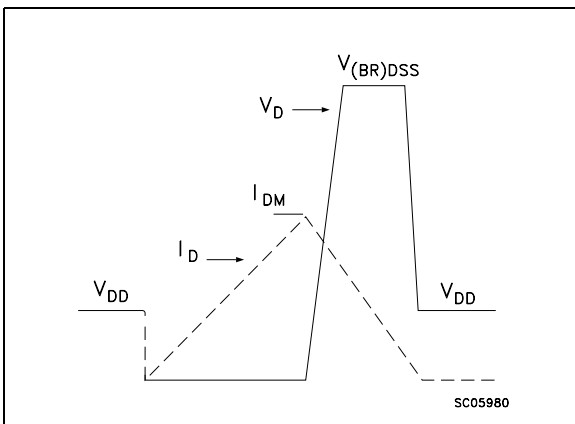
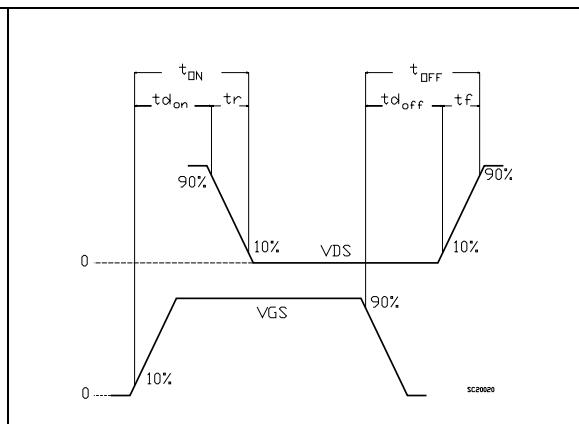

Figure 22. Switching time waveform



## 4 Package mechanical data

In order to meet environmental requirements, ST offers these devices in different grades of ECOPACK<sup>®</sup> packages, depending on their level of environmental compliance. ECOPACK<sup>®</sup> specifications, grade definitions and product status are available at: [www.st.com](http://www.st.com). ECOPACK is an ST trademark.

D<sup>2</sup>PAK (TO-263) mechanical data

Dim	mm			inch		
	Min	Typ	Max	Min	Typ	Max
A	4.40		4.60	0.173		0.181
A1	0.03		0.23	0.001		0.009
b	0.70		0.93	0.027		0.037
b2	1.14		1.70	0.045		0.067
c	0.45		0.60	0.017		0.024
c2	1.23		1.36	0.048		0.053
D	8.95		9.35	0.352		0.368
D1	7.50			0.295		
E	10		10.40	0.394		0.409
E1	8.50			0.334		
e		2.54			0.1	
e1	4.88		5.28	0.192		0.208
H	15		15.85	0.590		0.624
J1	2.49		2.69	0.099		0.106
L	2.29		2.79	0.090		0.110
L1	1.27		1.40	0.05		0.055
L2	1.30		1.75	0.051		0.069
R		0.4			0.016	
V2	0°		8°	0°		8°

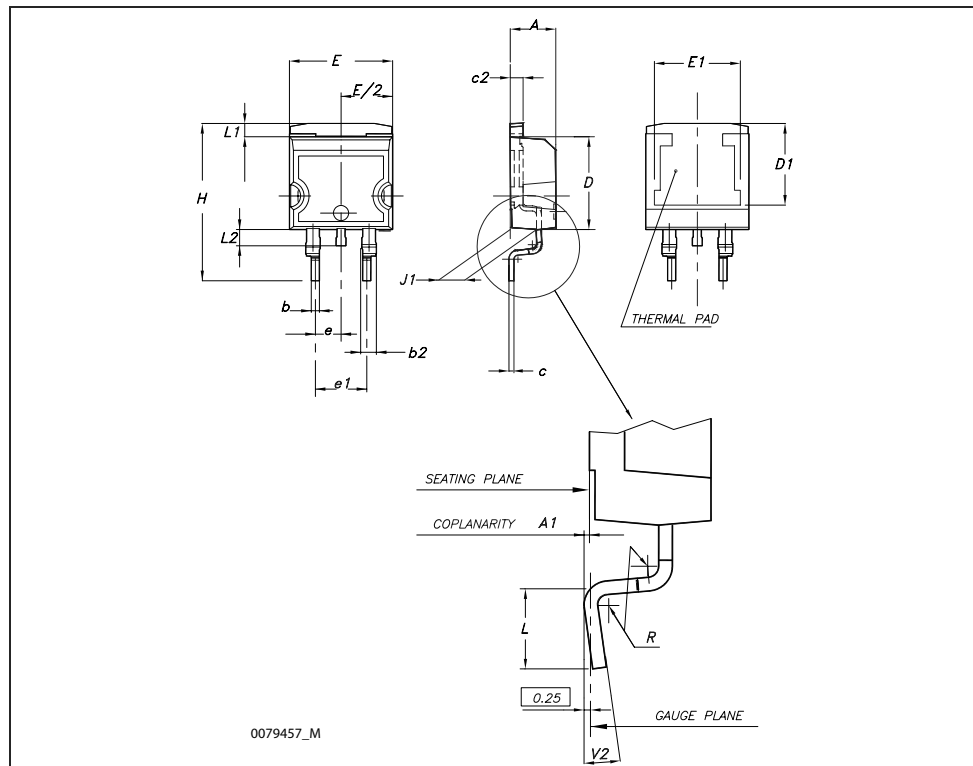

TO-220 mechanical data

Dim	mm			inch		
	Min	Typ	Max	Min	Typ	Max
A	4.40		4.60	0.173		0.181
b	0.61		0.88	0.024		0.034
b1	1.14		1.70	0.044		0.066
c	0.48		0.70	0.019		0.027
D	15.25		15.75	0.6		0.62
D1		1.27			0.050	
E	10		10.40	0.393		0.409
e	2.40		2.70	0.094		0.106
e1	4.95		5.15	0.194		0.202
F	1.23		1.32	0.048		0.051
H1	6.20		6.60	0.244		0.256
J1	2.40		2.72	0.094		0.107
L	13		14	0.511		0.551
L1	3.50		3.93	0.137		0.154
L20		16.40			0.645	
L30		28.90			1.137	
∅P	3.75		3.85	0.147		0.151
Q	2.65		2.95	0.104		0.116

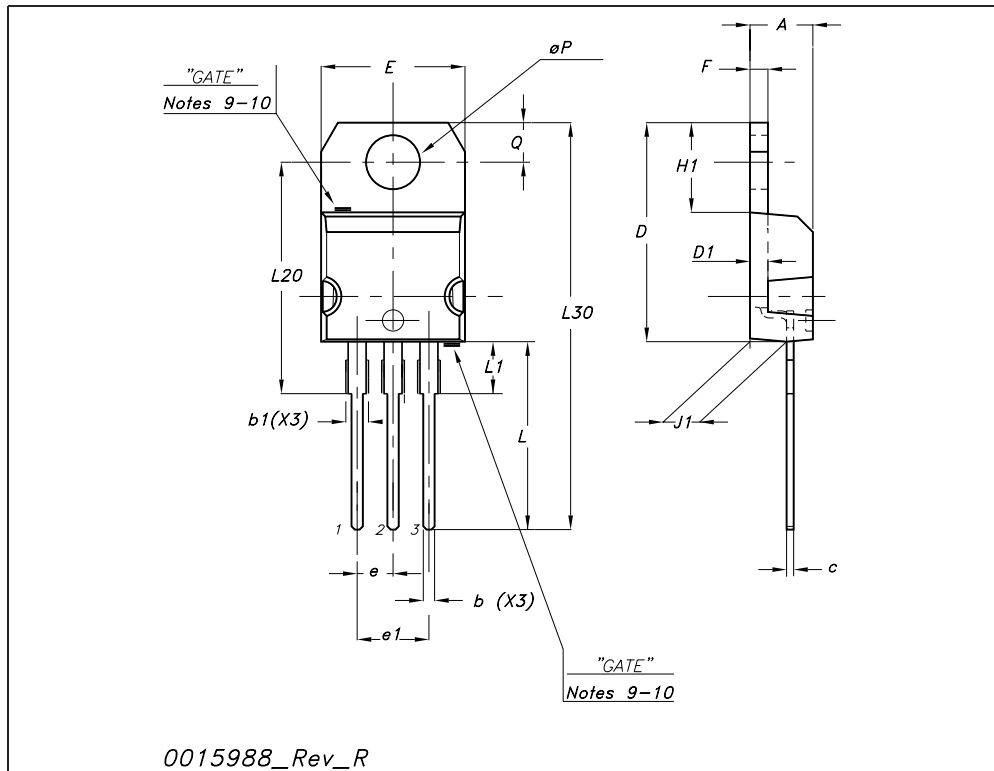

TO-220FP mechanical data

Dim.	mm		
	Min.	Typ.	Max.
A	4.4		4.6
B	2.5		2.7
D	2.5		2.75
E	0.45		0.7
F	0.75		1
F1	1.15		1.70
F2	1.15		1.5
G	4.95		5.2
G1	2.4		2.7
H	10		10.4
L2		16	
L3	28.6		30.6
L4	9.8		10.6
L5	2.9		3.6
L6	15.9		16.4
L7	9		9.3
Dia	3		3.2

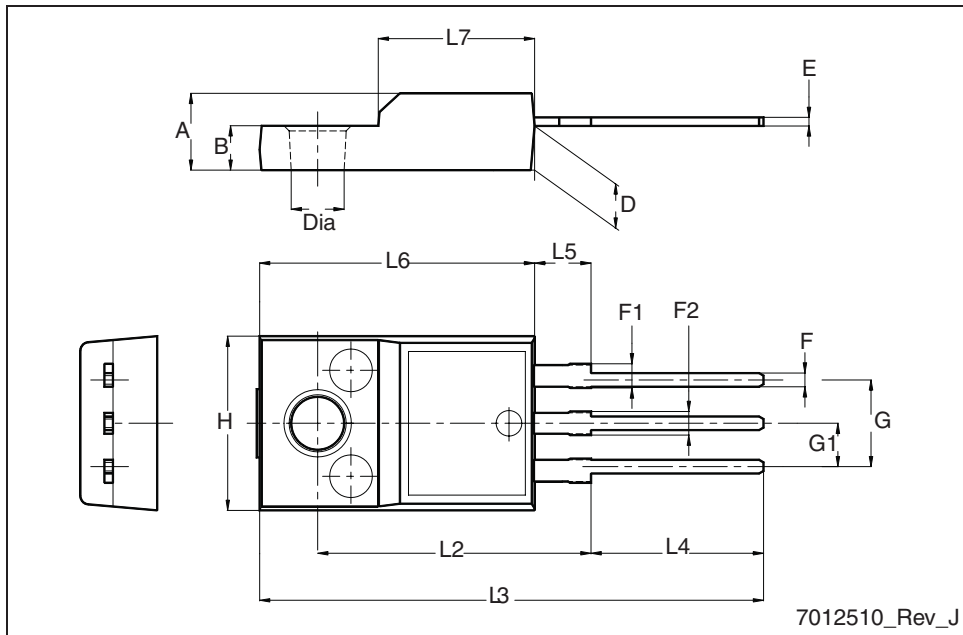

## 5 Packaging mechanical data

### D<sup>2</sup>PAK FOOTPRINT

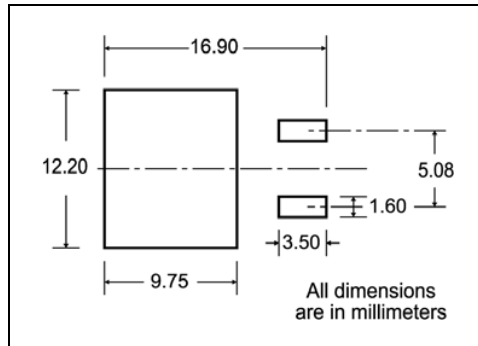

### TAPE AND REEL SHIPMENT

40 mm min. Access hole at slot location

Full radius

Tape slot in core for tape start 2.5mm min. width

Full radius

#### REEL MECHANICAL DATA

DIM.	mm		inch	
	MIN.	MAX.	MIN.	MAX.
A		330		12.992
B	1.5		0.059	
C	12.8	13.2	0.504	0.520
D	20.2		0.795	
G	24.4	26.4	0.960	1.039
N	100		3.937	
T		30.4		1.197

BASE QTY	BULK QTY
1000	1000

#### TAPE MECHANICAL DATA

DIM.	mm		inch	
	MIN.	MAX.	MIN.	MAX.
A0	10.5	10.7	0.413	0.421
B0	15.7	15.9	0.618	0.626
D	1.5	1.6	0.059	0.063
D1	1.59	1.61	0.062	0.063
E	1.65	1.85	0.065	0.073
F	11.4	11.6	0.449	0.456
K0	4.8	5.0	0.189	0.197
P0	3.9	4.1	0.153	0.161
P1	11.9	12.1	0.468	0.476
P2	1.9	2.1	0.075	0.082
R	50		1.574	
T	0.25	0.35	0.0098	0.0137
W	23.7	24.3	0.933	0.956

10 pitches cumulative tolerance on tape +/- 0.2 mm

Center line of cavity

User Direction of Feed

FEED DIRECTION

Bending radius R min.

\* on sales type

## 6 Revision history

Table 10. Document revision history

Date	Revision	Changes
23-Aug-2005	2	Preliminary version
28-Oct-2005	3	Complete version
26-Jul-2006	4	New template, no content change
22-Nov-2006	5	Corrected unit on <a href="#">Table 5.: On/off states</a>
18-Jan-2007	6	Typo mistakes on page 1
20-Apr-2009	7	Updated mechanical data



**Please Read Carefully:**

Information in this document is provided solely in connection with ST products. STMicroelectronics NV and its subsidiaries ("ST") reserve the right to make changes, corrections, modifications or improvements, to this document, and the products and services described herein at any time, without notice.

All ST products are sold pursuant to ST's terms and conditions of sale.

Purchasers are solely responsible for the choice, selection and use of the ST products and services described herein, and ST assumes no liability whatsoever relating to the choice, selection or use of the ST products and services described herein.

No license, express or implied, by estoppel or otherwise, to any intellectual property rights is granted under this document. If any part of this document refers to any third party products or services it shall not be deemed a license grant by ST for the use of such third party products or services, or any intellectual property contained therein or considered as a warranty covering the use in any manner whatsoever of such third party products or services or any intellectual property contained therein.

**UNLESS OTHERWISE SET FORTH IN ST'S TERMS AND CONDITIONS OF SALE ST DISCLAIMS ANY EXPRESS OR IMPLIED WARRANTY WITH RESPECT TO THE USE AND/OR SALE OF ST PRODUCTS INCLUDING WITHOUT LIMITATION IMPLIED WARRANTIES OF MERCHANTABILITY, FITNESS FOR A PARTICULAR PURPOSE (AND THEIR EQUIVALENTS UNDER THE LAWS OF ANY JURISDICTION), OR INFRINGEMENT OF ANY PATENT, COPYRIGHT OR OTHER INTELLECTUAL PROPERTY RIGHT.**

**UNLESS EXPRESSLY APPROVED IN WRITING BY AN AUTHORIZED ST REPRESENTATIVE, ST PRODUCTS ARE NOT RECOMMENDED, AUTHORIZED OR WARRANTED FOR USE IN MILITARY, AIR CRAFT, SPACE, LIFE SAVING, OR LIFE SUSTAINING APPLICATIONS, NOR IN PRODUCTS OR SYSTEMS WHERE FAILURE OR MALFUNCTION MAY RESULT IN PERSONAL INJURY, DEATH, OR SEVERE PROPERTY OR ENVIRONMENTAL DAMAGE. ST PRODUCTS WHICH ARE NOT SPECIFIED AS "AUTOMOTIVE GRADE" MAY ONLY BE USED IN AUTOMOTIVE APPLICATIONS AT USER'S OWN RISK.**

Resale of ST products with provisions different from the statements and/or technical features set forth in this document shall immediately void any warranty granted by ST for the ST product or service described herein and shall not create or extend in any manner whatsoever, any liability of ST.

ST and the ST logo are trademarks or registered trademarks of ST in various countries.

Information in this document supersedes and replaces all information previously supplied.

The ST logo is a registered trademark of STMicroelectronics. All other names are the property of their respective owners.

© 2009 STMicroelectronics - All rights reserved

STMicroelectronics group of companies

Australia - Belgium - Brazil - Canada - China - Czech Republic - Finland - France - Germany - Hong Kong - India - Israel - Italy - Japan - Malaysia - Malta - Morocco - Philippines - Singapore - Spain - Sweden - Switzerland - United Kingdom - United States of America

[www.st.com](http://www.st.com)

