

TRANSISTOR MODULE

QCA75AA100



UL;E76102 (M)

QCA75AA100 is a dual Darlington power transistor module which has series-connected high speed, high power Darlington transistors. Each transistor has a reverse paralleled fast recovery diode. The mounting base of the module is electrically isolated from semiconductor elements for simple heatsink construction,

- $I_C=75A$, $V_{CEX}=1000V$
- Low saturation voltage for higher efficiency.
- High DC current gain h_{FE}
- Isolated mounting base

(Applications)

Motor Control (VVVF), AC/DC Servo, UPS, Switching Power Supply, Ultrasonic Application

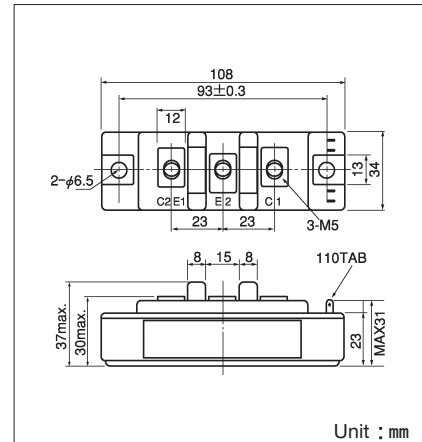
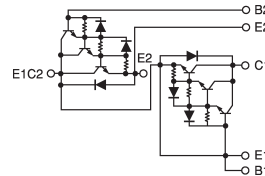

Maximum Ratings

($T_j=25^\circ C$)

Symbol	Item		Conditions	Ratings		Unit
				QCA75AA100		
V_{CBO}	Collector-Base Voltage			1000		V
V_{CEX}	Collector-Emitter Voltage		$V_{BE} = -2V$	1000		V
V_{EBO}	Emitter-Base Voltage			7		V
I_C	Collector Current			75		A
$-I_C$	Reverse Collector Current			75		A
I_B	Base Current			4		A
P_T	Total power dissipation		$T_C = 25^\circ C$	500		W
T_j	Junction Temperature			-40 ~ +150		$^\circ C$
T_{stg}	Storage Temperature			-40 ~ +125		$^\circ C$
V_{iso}	Isolation Voltage		A.C.1minute	2500		V
	Mounting Torque	Mounting (M6)	Recommended Value 2.5~3.9 (25~40)	4.7 (48)		N·m kgf·cm
		Terminal (M5)	Recommended Value 1.5~2.5 (15~25)	2.7 (28)		
	Mass		Typical Value	250		g

Electrical Characteristics

($T_j=25^\circ C$)

Symbol	Item		Conditions	Ratings		Unit
				Min.	Max.	
I_{CBO}	Collector Cut-off Current		$V_{CB} = 1000V$		1.0	mA
I_{EBO}	Emitter Cut-off Current		$V_{EB} = 7V$		200	mA
$V_{CEX(SUS)}$	Collector Emitter Sustaining Voltage		$I_C = 15A, I_{B2} = -4A$	1000		V
h_{FE}	DC Current Gain		$I_C = 75A, V_{CE} = 2.8V$	75		
			$I_C = 75A, V_{CE} = 5V$	100		
$V_{CE(sat)}$	Collector-Emitter Saturation Voltage		$I_C = 75A, I_B = 1.5A$		2.5	V
$V_{BE(sat)}$	Base-Emitter Saturation Voltage		$I_C = 75A, I_B = 1.5A$		3.5	V
t_{on}	Switching Time	On Time	$V_{CC} = 600V, I_C = 75A, I_{B1} = 1.5A, I_{B2} = -1.5A$		2.5	μs
t_s		Storage Time			15.0	
t_f		Fall Time			3.0	
V_{ECO}	Collector-Emitter Reverse Voltage		$-I_C = 75A$		1.8	V
$R_{th(j-c)}$	Thermal Impedance (junction to case)		Transistor part		0.25	$^\circ C/W$
			Diode part		1.20	

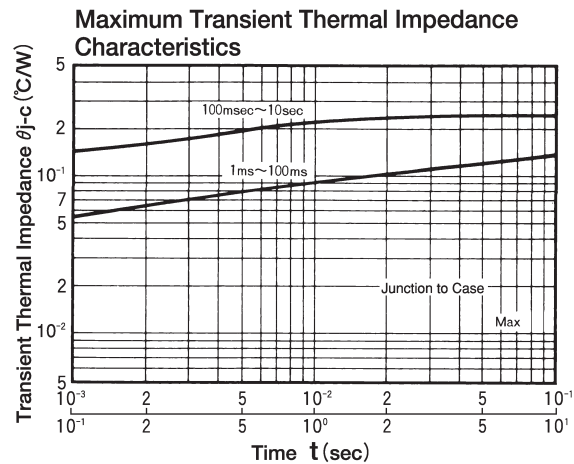
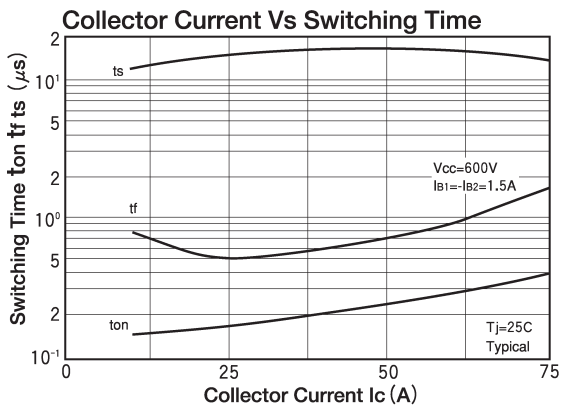
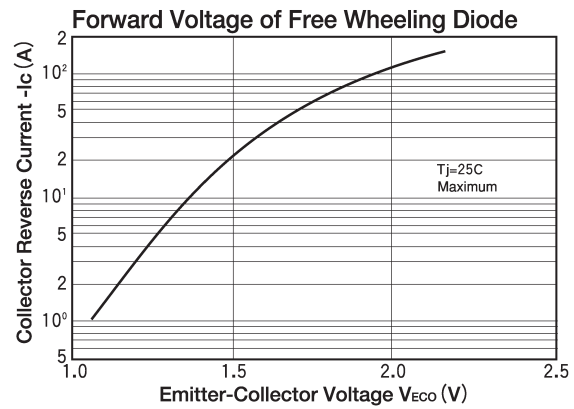
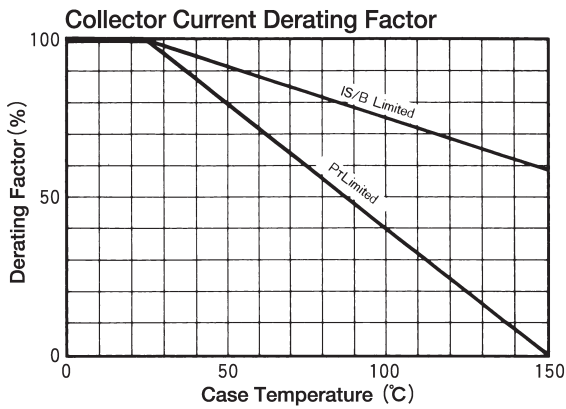
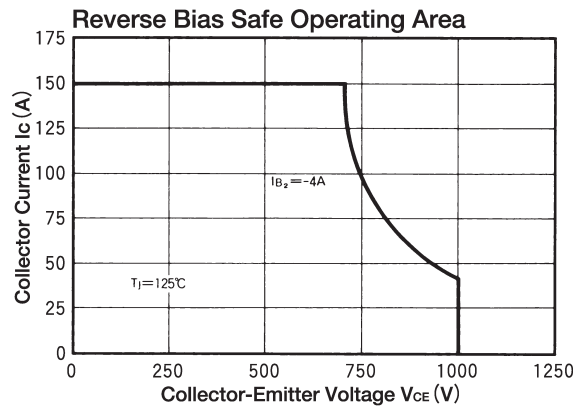
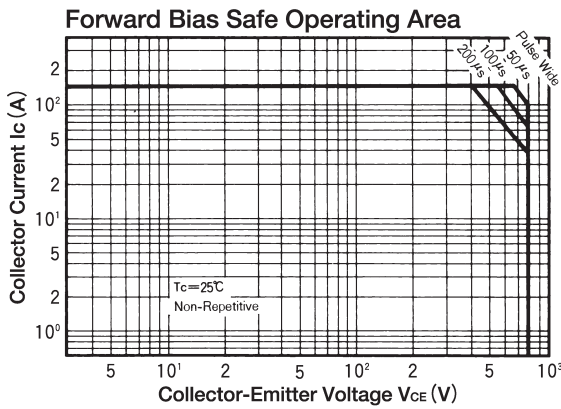
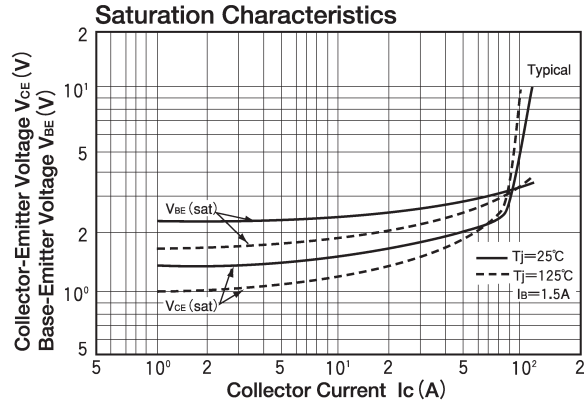
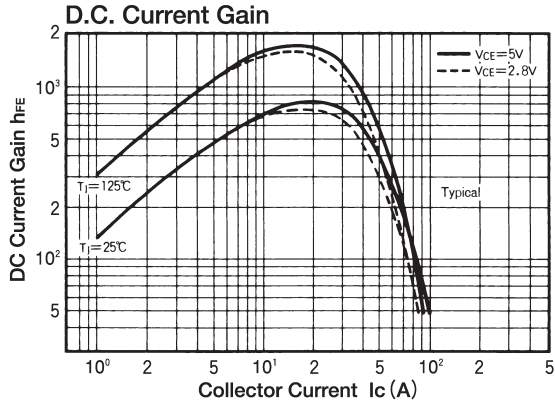

TRANSISTOR MODULE

QCA75AA120



UL;E76102 (M)

QCA75AA120 is a dual Darlington power transistor module which has series-connected high speed, high power Darlington transistors. Each transistor has a reverse paralleled fast recovery diode. The mounting base of the module is electrically isolated from semiconductor elements for simple heatsink construction,

- $I_C=75A$, $V_{CEX}=1200V$
- Low saturation voltage for higher efficiency.
- High DC current gain h_{FE}
- Isolated mounting base

(Applications)

Motor Control (VVVF), AC/DC Servo, UPS, Switching Power Supply, Ultrasonic Application

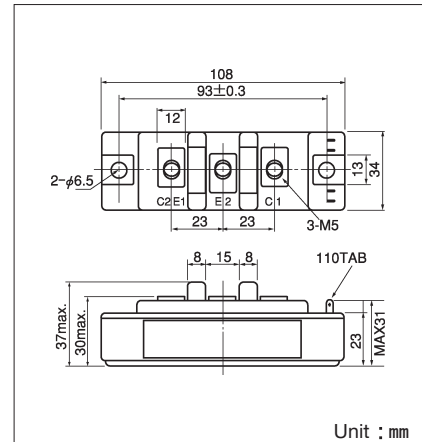
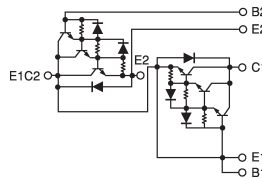

Maximum Ratings

($T_J=25^{\circ}C$)

Symbol	Item		Conditions	Ratings		Unit
				QCA75AA120		
V_{CBO}	Collector-Base Voltage			1200		V
V_{CEX}	Collector-Emitter Voltage		$V_{BE} = -2V$	1200		V
V_{EBO}	Emitter-Base Voltage			10		V
I_C	Collector Current			75		A
$-I_C$	Reverse Collector Current			75		A
I_B	Base Current			4		A
P_T	Total power dissipation		$T_C = 25^{\circ}C$	500		W
T_J	Junction Temperature			$-40 \sim +150$		$^{\circ}C$
T_{stg}	Storage Temperature			$-40 \sim +125$		$^{\circ}C$
V_{iso}	Isolation Voltage		A.C.1minute	2500		V
	Mounting Torque	Mounting (M6)	Recommended Value 2.5~3.9 (25~40)	4.7 (48)		N·m (kgf·cm)
		Terminal (M5)	Recommended Value 1.5~2.5 (15~25)	2.7 (28)		
	Mass		Typical Value	250		g

Electrical Characteristics

($T_J=25^{\circ}C$)

Symbol	Item		Conditions	Ratings		Unit
				Min.	Max.	
I_{CBO}	Collector Cut-off Current		$V_{CB} = 1200V$		1.0	mA
I_{EBO}	Emitter Cut-off Current		$V_{EB} = 10V$		300	mA
$V_{CEX(SUS)}$	Collector Emitter Sustaining Voltage		$I_C = 15A, I_{B2} = -3A$	1200		V
h_{FE}	DC Current Gain		$I_C = 75A, V_{CE} = 5V$	75		
$V_{CE(sat)}$	Collector-Emitter Saturation Voltage		$I_C = 75A, I_B = 1.5A$		3.0	V
$V_{BE(sat)}$	Base-Emitter Saturation Voltage		$I_C = 75A, I_B = 1.5A$		3.5	V
t_{on}	Switching Time	On Time	$V_{CC} = 600V, I_C = 75A$ $I_{B1} = 1.5A, I_{B2} = -1.5A$		2.5	μs
t_s		Storage Time			15.0	
t_f		Fall Time			3.0	
V_{ECO}	Collector-Emitter Reverse Voltage		$-I_C = 75A$		1.8	V
$R_{th(j-c)}$	Thermal Impedance (junction to case)		Transistor part		0.25	$^{\circ}C/W$
			Diode part		1.2	

