



LXT972A

3.3V Dual-Speed Fast Ethernet Transceiver Datasheet

Datasheet

The LXT972A is an IEEE compliant Fast Ethernet PHY Transceiver that directly supports both 100BASE-TX and 10BASE-T applications. It provides a Media Independent Interface (MII) for easy attachment to 10/100 Media Access Controllers (MACs).

This document also supports the LXT972.

The LXT972A supports full-duplex operation at 10Mbps and 100Mbps. Its operating condition can be set using auto-negotiation, parallel detection, or manual control.

The LXT972A is fabricated with an advanced CMOS process and requires only a single 3.3V power supply.

Applications

- Combination 10BASE-T/100BASE-TX Network Interface Cards (NICs)
- 10/100 PCMCIA Cards
- Cable Modems and Set-Top Boxes

Product Features

- 3.3V Operation.
- Low power consumption (300 mW typical).
- 10BASE-T and 100BASE-TX using a single RJ-45 connection.
- Supports auto-negotiation and parallel detection.
- MII interface with extended register capability.
- Robust baseline wander correction performance.
- Standard CSMA/CD or full-duplex operation.
- Configurable via MDIO serial port or hardware control pins.
- Integrated, programmable LED drivers.
- 64-pin Low-profile Quad Flat Package (LQFP).
 - LXT972ALC - Commercial (0° to 70°C ambient).

As of January 15, 2001, this document replaces the Level One document LXT972A 3.3V Dual-Speed Fast Ethernet Transceiver Datasheet.

Order Number: 249186-002
January 2001



Information in this document is provided in connection with Intel® products. No license, express or implied, by estoppel or otherwise, to any intellectual property rights is granted by this document. Except as provided in Intel's Terms and Conditions of Sale for such products, Intel assumes no liability whatsoever, and Intel disclaims any express or implied warranty, relating to sale and/or use of Intel products including liability or warranties relating to fitness for a particular purpose, merchantability, or infringement of any patent, copyright or other intellectual property right. Intel products are not intended for use in medical, life saving, or life sustaining applications.

Intel may make changes to specifications and product descriptions at any time, without notice.

Designers must not rely on the absence or characteristics of any features or instructions marked "reserved" or "undefined." Intel reserves these for future definition and shall have no responsibility whatsoever for conflicts or incompatibilities arising from future changes to them.

The LXT972A may contain design defects or errors known as errata which may cause the product to deviate from published specifications. Current characterized errata are available on request.

Contact your local Intel sales office or your distributor to obtain the latest specifications and before placing your product order.

Copies of documents which have an ordering number and are referenced in this document, or other Intel literature may be obtained by calling 1-800-548-4725 or by visiting Intel's website at <http://www.intel.com>.

Copyright © Intel Corporation, 2001

*Third-party brands and names are the property of their respective owners.

Datasheet

Contents

1.0	Pin Assignments	10
2.0	Signal Descriptions	13
3.0	Functional Description	16
3.1	Introduction.....	16
3.1.1	Comprehensive Functionality	16
3.1.2	OSP™ Architecture	16
3.2	Network Media / Protocol Support.....	17
3.2.1	10/100 Network Interface	17
3.2.1.1	Twisted-Pair Interface	17
3.2.1.2	Fault Detection and Reporting.....	17
3.2.2	MII Data Interface.....	18
3.2.3	Configuration Management Interface	18
3.2.3.1	MDIO Management Interface	18
3.2.3.2	MII Interrupts	19
3.2.3.3	Hardware Control Interface	19
3.3	Operating Requirements	20
3.3.1	Power Requirements.....	20
3.3.2	Clock Requirements	20
3.3.2.1	External Crystal/Oscillator	20
3.3.2.2	MDIO Clock	20
3.4	Initialization.....	21
3.4.1	MDIO Control Mode	21
3.4.2	Hardware Control Mode	21
3.4.3	Reduced Power Modes	22
3.4.3.1	Hardware Power Down	22
3.4.3.2	Software Power Down	22
3.4.4	Reset.....	23
3.4.5	Hardware Configuration Settings	23
3.5	Establishing Link	24
3.5.1	Auto-Negotiation.....	24
3.5.1.1	Base Page Exchange.....	24
3.5.1.2	Next Page Exchange.....	24
3.5.1.3	Controlling Auto-Negotiation	25
3.5.2	Parallel Detection	25
3.6	MII Operation.....	25
3.6.1	MII Clocks.....	26
3.6.2	Transmit Enable	26
3.6.3	Receive Data Valid.....	26
3.6.4	Carrier Sense	26
3.6.5	Error Signals.....	26
3.6.6	Collision.....	26
3.6.7	Loopback.....	28
3.6.7.1	Operational Loopback	28
3.6.7.2	Test Loopback.....	28
3.7	100Mbps Operation.....	29

3.7.1	100BASE-X Network Operations	29
3.7.2	Collision Indication	31
3.7.3	100BASE-X Protocol Sublayer Operations	31
3.7.3.1	PCS Sublayer	31
3.7.3.2	PMA Sublayer	34
3.7.3.3	Twisted-Pair PMD Sublayer	34
3.8	10Mbps Operation	35
3.8.1	10T Preamble Handling	35
3.8.2	10T Carrier Sense	36
3.8.3	10T Dribble Bits	36
3.8.4	10T Link Integrity Test	36
3.8.4.1	Link Failure	36
3.8.5	10T SQE (Heartbeat)	36
3.8.6	10T Jabber	36
3.8.7	10T Polarity Correction	37
3.9	Monitoring Operations	37
3.9.1	Monitoring Auto-Negotiation	37
3.9.1.1	Monitoring Next Page Exchange	37
3.9.2	LED Functions	37
3.9.2.1	LED Pulse Stretching	38
3.10	Boundary Scan (JTAG1149.1) Functions	38
3.10.1	Boundary Scan Interface	38
3.10.2	State Machine	39
3.10.3	Instruction Register	39
3.10.4	Boundary Scan Register (BSR)	39
4.0	Application Information	40
4.1	Magnetics Information	40
4.2	Typical Twisted-Pair Interface	40
5.0	Test Specifications	44
5.1	Electrical Parameters	44
5.2	Timing Diagrams	47
6.0	Register Definitions	55
7.0	Package Specification	70

Figures

1	LXT972A Block Diagram	9
2	LXT972A 64-Pin LQFP Assignments	10
3	Management Interface Read Frame Structure	19
4	Management Interface Write Frame Structure	19
5	Interrupt Logic	20
6	Initialization Sequence	22
7	Hardware Configuration Settings	23
8	Link Establishment Overview	25
9	10BASE-T Clocking	27
10	100BASE-X Clocking	27
11	Link Down Clock Transition	27
12	Loopback Paths	28
13	100BASE-X Frame Format	29
14	100BASE-TX Data Path	29
15	100BASE-TX Reception with no Errors	30
16	100BASE-TX Reception with Invalid Symbol	30
17	100BASE-TX Transmission with no Errors	31
18	100BASE-TX Transmission with Collision	31
19	Protocol Sublayers	32
20	LED Pulse Stretching	38
21	Typical Twisted-Pair Interface - Switch	41
22	Typical Twisted-Pair Interface - NIC	42
23	Typical MII Interface	43
24	100BASE-TX Receive Timing - 4B Mode	47
25	100BASE-TX Transmit Timing - 4B Mode	48
26	10BASE-T Receive Timing	49
27	10BASE-T Transmit Timing	50
28	10BASE-T Jabber and Unjabber Timing	51
29	10BASE-T SQE (Heartbeat) Timing	51
30	Auto Negotiation and Fast Link Pulse Timing	52
31	Fast Link Pulse Timing	52
32	MDIO Input Timing	53
33	MDIO Output Timing	53
34	Power-Up Timing	54
35	RESET Pulse Width and Recovery Timing	54
36	PHY Identifier Bit Mapping	60
37	LXT972A LQFP Package Specifications	70

Tables

1	LQFP Numeric Pin List.....	11
2	LXT972A MII Signal Descriptions.....	13
3	LXT972A Network Interface Signal Descriptions	14
4	LXT972A Miscellaneous Signal Descriptions.....	14
5	LXT972A Power Supply Signal Descriptions	15
6	LXT972A JTAG Test Signal Descriptions	15
7	LXT972A LED Signal Descriptions.....	15
8	Hardware Configuration Settings	24

9	Carrier Sense, Loopback, and Collision Conditions	28
10	4B/5B Coding	33
11	BSR Mode of Operation	39
12	Supported JTAG Instructions	39
13	Device ID Register	39
14	Magnetics Requirements	40
15	RJ-45 Pin Comparison of NIC and Switch Twisted-Pair Interfaces	40
16	Absolute Maximum Ratings	44
17	Operating Conditions	44
18	Digital I/O Characteristics 1	45
19	Digital I/O Characteristics - MII Pins	45
20	I/O Characteristics - REFCLK/XI and XO Pins	45
21	I/O Characteristics - LED/CFG Pins	45
22	100BASE-TX Transceiver Characteristics	46
23	10BASE-T Transceiver Characteristics	46
24	10BASE-T Link Integrity Timing Characteristics	46
25	100BASE-TX Receive Timing Parameters - 4B Mode	47
26	100BASE-TX Transmit Timing Parameters - 4B Mode	48
27	10BASE-T Receive Timing Parameters	49
28	10BASE-T Transmit Timing Parameters	50
29	10BASE-T Jabber and Unjabber Timing Parameters	51
30	10BASE-T SQE Timing Parameters	51
31	Auto Negotiation and Fast Link Pulse Timing Parameters	52
32	MDIO Timing Parameters	53
33	Power-Up Timing Parameters	54
34	RESET Pulse Width and Recovery Timing Parameters	54
35	Register Set	55
36	Register Bit Map	56
37	Control Register (Address 0)	58
38	MII Status Register #1 (Address 1)	58
39	PHY Identification Register 1 (Address 2)	59
40	PHY Identification Register 2 (Address 3)	60
41	Auto Negotiation Advertisement Register (Address 4)	61
42	Auto Negotiation Link Partner Base Page Ability Register (Address 5)	62
43	Auto Negotiation Expansion (Address 6)	63
44	Auto Negotiation Next Page Transmit Register (Address 7)	63
45	Auto Negotiation Link Partner Next Page Receive Register (Address 8)	64
46	Configuration Register (Address 16, Hex 10)	64
47	Status Register #2 (Address 17)	65
48	Interrupt Enable Register (Address 18)	66
49	Interrupt Status Register (Address 19, Hex 13)	66
50	LED Configuration Register (Address 20, Hex 14)	68
51	Transmit Control Register #2 (Address 30)	69

Revision History

Revision	Date	Description
002	January 2001	Clock Requirements: Modified language under Clock Requirements heading.
		I/O Characteristics REFCLK (table): Changed values for Input Clock Duty Cycle under Min from 40 to 35 and under Max from 60 to 65.

Figure 1. LXT972A Block Diagram

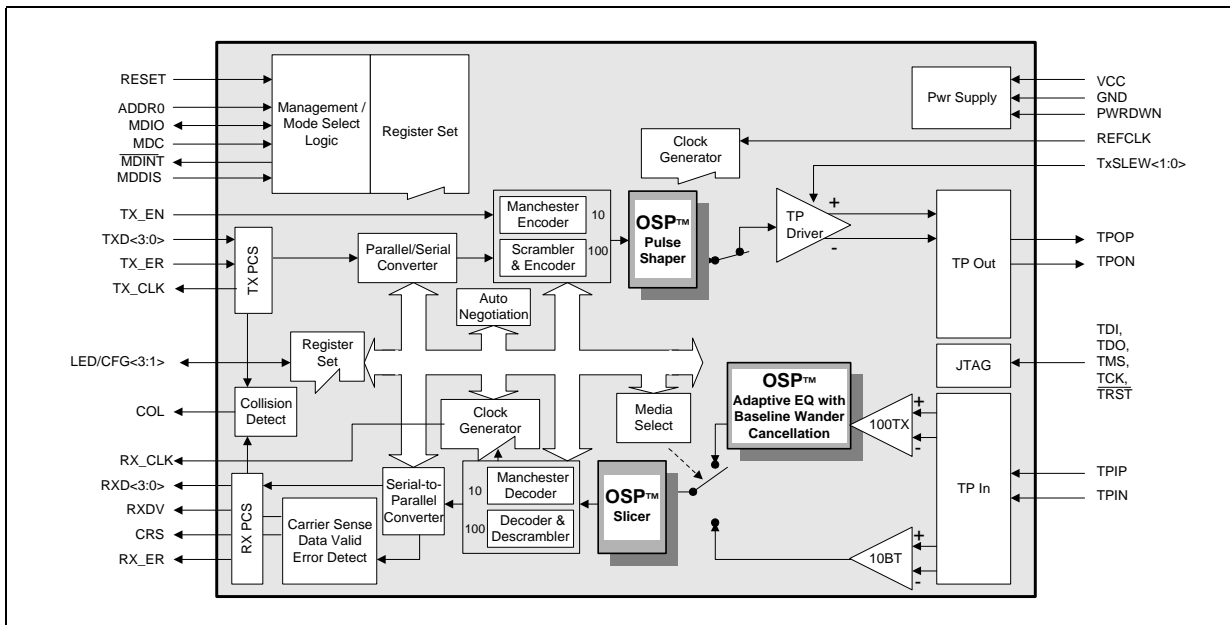

1.0 Pin Assignments

Figure 2. LXT972A 64-Pin LQFP Assignments

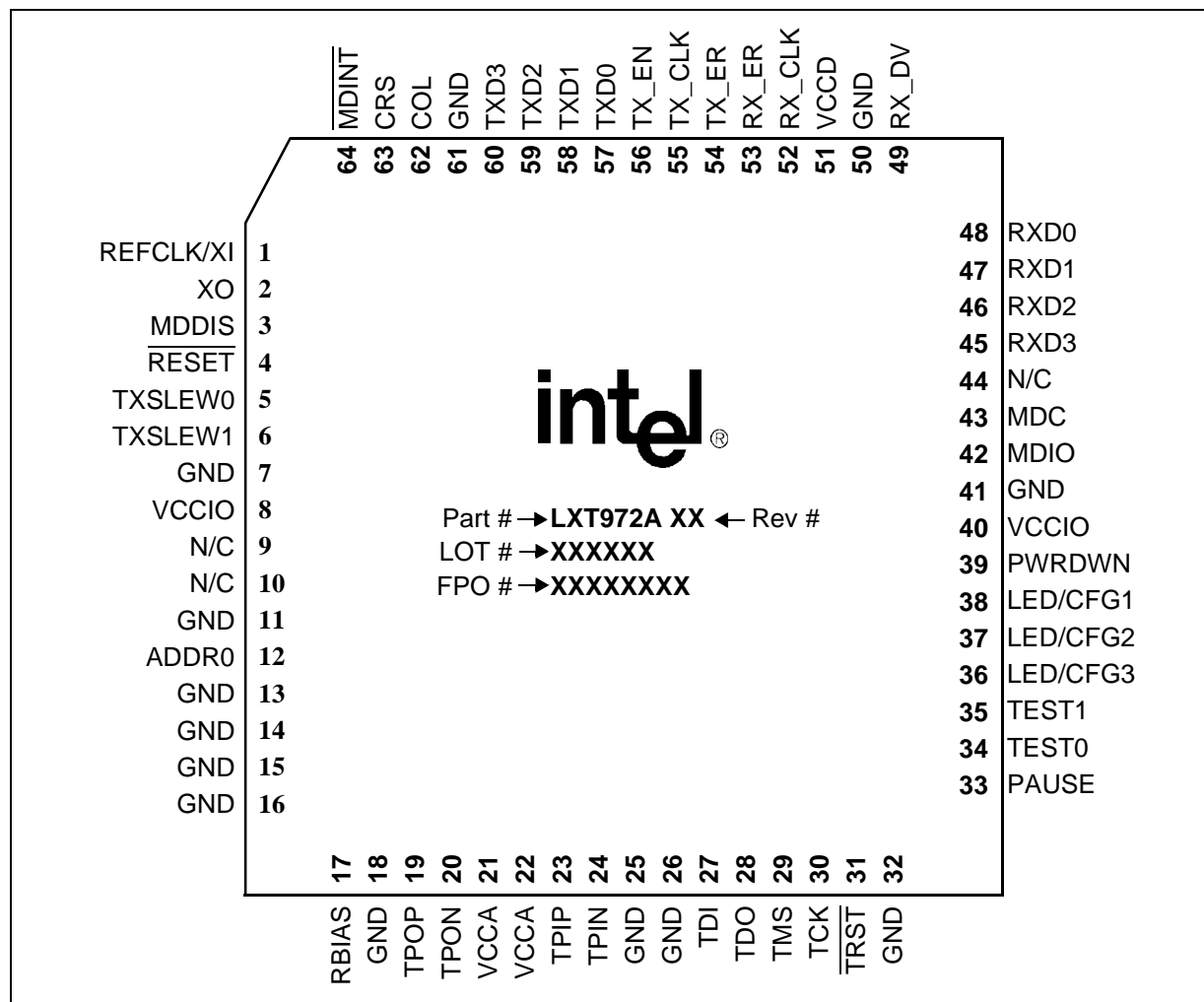

Package Topside Markings

Marking	Definition
Part #	LXT972A is the unique identifier for this product family.
Rev #	Identifies the particular silicon "stepping" (Refer to Specification Update for additional stepping information.)
Lot #	Identifies the batch.
FPO #	Identifies the Finish Process Order.

Table 1. LQFP Numeric Pin List

Pin	Symbol	Type	Reference for Full Description
1	REFCLK/XI	Input	Table 4 on page 14
2	XO	Output	Table 4 on page 14
3	MDDIS	Input	Table 2 on page 13
4	RESET	Input	Table 4 on page 14
5	TxSLEW0	Input	Table 4 on page 14
6	TxSLEW1	Input	Table 4 on page 14
7	GND	–	Table 5 on page 15
8	VCCIO	–	Table 5 on page 15
9	N/C	–	Table 4 on page 14
10	N/C	–	Table 4 on page 14
11	GND	–	Table 5 on page 15
12	ADDR0	Input	Table 4 on page 14
13	GND	–	Table 5 on page 15
14	GND	–	Table 5 on page 15
15	GND	–	Table 5 on page 15
16	GND	–	Table 5 on page 15
17	RBIAS	Analog Input	Table 4 on page 14
18	GND	–	Table 5 on page 15
19	TPOP	Output	Table 3 on page 14
20	TPON	Output	Table 3 on page 14
21	VCCA	–	Table 5 on page 15
22	VCCA	–	Table 5 on page 15
23	TPIP	Input	Table 3 on page 14
24	TPIN	Input	Table 3 on page 14
25	GND	–	Table 5 on page 15
26	GND	–	Table 5 on page 15
27	TDI	Input	Table 6 on page 15
28	TDO	Output	Table 6 on page 15
29	TMS	Input	Table 6 on page 15
30	TCK	Input	Table 6 on page 15
31	TRST	Input	Table 6 on page 15
32	GND	–	Table 5 on page 15
33	PAUSE	Input	Table 4 on page 14
34	TEST0	Input	Table 4 on page 14
35	TEST1	Input	Table 4 on page 14
36	LED/CFG3	I/O	Table 7 on page 15

Table 1. LQFP Numeric Pin List (Continued)

Pin	Symbol	Type	Reference for Full Description
37	LED/CFG2	I/O	Table 7 on page 15
38	LED/CFG1	I/O	Table 7 on page 15
39	PWRDWN	Input	Table 4 on page 14
40	VCCIO	–	Table 5 on page 15
41	GND	–	Table 5 on page 15
42	MDIO	I/O	Table 2 on page 13
43	MDC	Input	Table 2 on page 13
44	N/C	–	Table 4 on page 14
45	RXD3	Output	Table 2 on page 13
46	RXD2	Output	Table 2 on page 13
47	RXD1	Output	Table 2 on page 13
48	RXD0	Output	Table 2 on page 13
49	RX_DV	Output	Table 2 on page 13
50	GND	–	Table 5 on page 15
51	VCCD	–	Table 5 on page 15
52	RX_CLK	Output	Table 2 on page 13
53	RX_ER	Output	Table 2 on page 13
54	TX_ER	Input	Table 2 on page 13
55	TX_CLK	Output	Table 2 on page 13
56	TX_EN	Input	Table 2 on page 13
57	TXD0	Input	Table 2 on page 13
58	TXD1	Input	Table 2 on page 13
59	TXD2	Input	Table 2 on page 13
60	TXD3	Input	Table 2 on page 13
61	GND	–	Table 5 on page 15
62	COL	Output	Table 2 on page 13
63	CRS	Output	Table 2 on page 13
64	MDINT	Open Drain	Table 2 on page 13

2.0 Signal Descriptions

Table 2. LXT972A MII Signal Descriptions

LQFP Pin#	Symbol	Type ¹	Signal Description
Data Interface Pins			
60 59 58 57	TXD3 TXD2 TXD1 TXD0	I	Transmit Data. TXD is a bundle of parallel data signals that are driven by the MAC. TXD<3:0> shall transition synchronously with respect to the TX_CLK. TXD<0> is the least significant bit.
56	TX_EN	I	Transmit Enable. The MAC asserts this signal when it drives valid data on TXD. This signal must be synchronized to TX_CLK.
55	TX_CLK	O	Transmit Clock. TX_CLK is sourced by the PHY in both 10 and 100Mbps operations. 2.5 MHz for 10Mbps operation, 25 MHz for 100Mbps operation.
45 46 47 48	RXD3 RXD2 RXD1 RXD0	O	Receive Data. RXD is a bundle of parallel signals that transition synchronously with respect to the RX_CLK. RXD<0> is the least significant bit.
49	RX_DV	O	Receive Data Valid. The LXT972A asserts this signal when it drives valid data on RXD. This output is synchronous to RX_CLK.
53	RX_ER	O	Receive Error. Signals a receive error condition has occurred. This output is synchronous to RX_CLK.
54	TX_ER	I	Transmit Error. Signals a transmit error condition. This signal must be synchronized to TX_CLK.
52	RX_CLK	O	Receive Clock. 25 MHz for 100Mbps operation, 2.5 MHz for 10Mbps operation. Refer to “Clock Requirements” on page 20 in the Functional Description section.
62	COL	O	Collision Detected. The LXT972A asserts this output when a collision is detected. This output remains High for the duration of the collision. This signal is asynchronous and is inactive during full-duplex operation.
63	CRS	O	Carrier Sense. During half-duplex operation (bit 0.8 = 0), the LXT972A asserts this output when either transmitting or receiving data packets. During full-duplex operation (bit 0.8 = 1), CRS is asserted during receive. CRS assertion is asynchronous with respect to RX_CLK. CRS is de-asserted on loss of carrier, synchronous to RX_CLK.
MDIO Control Interface Pins			
3	MDDIS	I	Management Disable. When MDDIS is High, the MDIO is disabled from read and write operations. When MDDIS is Low at power up or reset, the Hardware Control Interface pins control only the initial or “default” values of their respective register bits. After the power-up/reset cycle is complete, bit control reverts to the MDIO serial channel.
43	MDC	I	Management Data Clock. Clock for the MDIO serial data channel. Maximum frequency is 8 MHz.
42	MDIO	I/O	Management Data Input/Output. Bidirectional serial data channel for PHY/STA communication.
64	$\overline{\text{MDINT}}$	OD	Management Data Interrupt. When bit 18.1 = 1, an active Low output on this pin indicates status change. Interrupt is cleared by reading Register 19.
1. Type Column Coding: I = Input, O = Output, A = Analog, OD = Open Drain.			

Table 3. LXT972A Network Interface Signal Descriptions

LQFP Pin#	Symbol	Type ¹	Signal Description
19 20	TPOP TPON	O	Twisted-Pair Outputs, Positive & Negative. During 100BASE-TX or 10BASE-T operation, TPOP/N pins drive 802.3 compliant pulses onto the line.
23 24	TPIP TPIN	I	Twisted-Pair Inputs, Positive & Negative. During 100BASE-TX or 10BASE-T operation, TPIP/N pins receive differential 100BASE-TX or 10BASE-T signals from the line.

1. Type Column Coding: I = Input, O = Output, A = Analog, OD = Open Drain

Table 4. LXT972A Miscellaneous Signal Descriptions

LQFP Pin#	Symbol	Type ¹	Signal Description		
5 6	TxSLEW0 TxSLEW1	I	Tx Output Slew Controls 0 and 1. These pins select the TX output slew rate (rise and fall time) as follows:		
			TxSLEW1	TxSLEW0	Slew Rate (Rise and Fall Time)
			0	0	2.5 ns
			0	1	3.1 ns
			1	0	3.7 ns
1	1	4.3 ns			
4	$\overline{\text{RESET}}$	I	Reset. This active Low input is OR'ed with the control register Reset bit (0.15). The LXT972A reset cycle is extended to 258 μs (nominal) after reset is deasserted.		
12	ADDR0	I	Address0. Sets device address.		
17	RBIAS	AI	Bias. This pin provides bias current for the internal circuitry. Must be tied to ground through a 22.1 k Ω , 1% resistor.		
33	PAUSE	I	Pause. When set High, the LXT972A advertises Pause capabilities during auto negotiation.		
34	TEST0	I	Test. Tie Low.		
35	TEST1	I	Test. Tie Low.		
39	PWRDWN	I	Power Down. When set High, this pin puts the LXT972A in a power-down mode.		
1 2	REFCLK/XI XO	I O	Crystal Input and Output. A 25 MHz crystal oscillator circuit can be connected across XI and XO. A clock can also be used at XI. Refer to Functional Description for detailed clock requirements.		
9, 10, 44	N/C	-	No Connection. These pins are not used and should not be terminated.		

1. Type Column Coding: I = Input, O = Output, A = Analog, OD = Open Drain

Table 5. LXT972A Power Supply Signal Descriptions

LQFP Pin#	Symbol	Type	Signal Description
51	VCCD	-	Digital Power. Requires a 3.3V power supply.
7, 11, 13, 14, 15, 16, 18, 25, 26, 32, 41, 50, 61	GND	-	Ground.
8, 40	VCCIO	-	MII Power. Requires either a 3.3V or a 2.5V supply. Must be supplied from the same source used to power the MAC on the other side of the MII.
21, 22	VCCA	-	Analog Power. Requires a 3.3V power supply.

Table 6. LXT972A JTAG Test Signal Descriptions

LQFP Pin#	Symbol	Type ¹	Signal Description
27	TDI ²	I	Test Data Input. Test data sampled with respect to the rising edge of TCK.
28	TDO ²	O	Test Data Output. Test data driven with respect to the falling edge of TCK.
29	TMS ²	I	Test Mode Select.
30	TCK ²	I	Test Clock. Test clock input sourced by ATE.
31	$\overline{\text{TRST}}^2$	I	Test Reset. Test reset input sourced by ATE.

1. Type Column Coding: I = Input, O = Output, A = Analog, OD = Open Drain.
 2. If JTAG port is not used, these pins do not need to be terminated.

Table 7. LXT972A LED Signal Descriptions

LQFP Pin#	Symbol	Type ¹	Signal Description
38 37 36	LED/CFG1 LED/CFG2 LED/CFG3	I/O	LED Drivers 1 -3. These pins drive LED indicators. Each LED can display one of several available status conditions as selected by the LED Configuration Register (refer to Table 50 on page 68 for details). Configuration Inputs 1-3. These pins also provide initial configuration settings (refer to Table 8 on page 24 for details).

1. Type Column Coding: I = Input, O = Output, A = Analog, OD = Open Drain

3.0 Functional Description

3.1 Introduction

The LXT972A is a single-port Fast Ethernet 10/100 Transceiver that supports 10Mbps and 100Mbps networks. It complies with all applicable requirements of IEEE 802.3. The LXT972A can directly drive either a 100BASE-TX line (up to 140 meters) or a 10BASE-T line (up to 185 meters).

3.1.1 Comprehensive Functionality

The LXT972A provides a standard Media Independent Interface (MII) for 10/100 MACs. The LXT972A performs all functions of the Physical Coding Sublayer (PCS) and Physical Media Attachment (PMA) sublayer as defined in the IEEE 802.3 100BASE-X standard. This device also performs all functions of the Physical Media Dependent (PMD) sublayer for 100BASE-TX connections.

On power-up, the LXT972A reads its configuration pins to check for forced operation settings. If not configured for forced operation, it uses auto-negotiation/parallel detection to automatically determine line operating conditions. If the PHY device on the other side of the link supports auto-negotiation, the LXT972A auto-negotiates with it using Fast Link Pulse (FLP) Bursts. If the PHY partner does not support auto-negotiation, the LXT972A automatically detects the presence of either link pulses (10Mbps PHY) or Idle symbols (100Mbps PHY) and set its operating conditions accordingly.

The LXT972A provides half-duplex and full-duplex operation at 100Mbps and 10Mbps.

3.1.2 OSP™ Architecture

Intel's LXT972A incorporates high-efficiency Optimal Signal Processing™ design techniques, combining the best properties of digital and analog signal processing to produce a truly optimal device.

The receiver utilizes decision feedback equalization to increase noise and cross-talk immunity by as much as 3 dB over an ideal all-analog equalizer. Using OSP mixed-signal processing techniques in the receive equalizer avoids the quantization noise and calculation truncation errors found in traditional DSP-based receivers (typically complex DSP engines with A/D converters). This results in improved receiver noise and cross-talk performance.

The OSP signal processing scheme also requires substantially less computational logic than traditional DSP-based designs. This lowers power consumption and also reduces the logic switching noise generated by DSP engines. This logic switching noise can be a considerable source of EMI generated on the device's power supplies.

The OSP-based LXT972A provides improved data recovery, EMI performance and low power consumption.

3.2 Network Media / Protocol Support

The LXT972A supports both 10BASE-T and 100BASE-TX Ethernet over twisted-pair.

3.2.1 10/100 Network Interface

The network interface port consists of two differential signal pairs. Refer to [Table 3](#) for specific pin assignments.

The LXT972A output drivers generate either 100BASE-TX or 10BASE-T. When not transmitting data, the LXT972A generates 802.3-compliant link pulses or idle code. Input signals are decoded either as a 100BASE-TX or 10BASE-T input, depending on the mode selected. Auto-negotiation/parallel detection or manual control is used to determine the speed of this interface.

3.2.1.1 Twisted-Pair Interface

The LXT972A supports either 100BASE-TX or 10BASE-T connections over 100 Ω , Category 5, Unshielded Twisted Pair (UTP) cable. When operating at 100Mbps, the LXT972A continuously transmits and receives MLT3 symbols. When not transmitting data, the LXT972A generates “IDLE” symbols.

During 10Mbps operation, Manchester-encoded data is exchanged. When no data is being exchanged, the line is left in an idle state. Link pulses are transmitted periodically to keep the link up.

Only a transformer, RJ-45 connector, load resistor, and bypass capacitors are required to complete this interface. On the transmit side, the LXT972A has an active internal termination and does not require external termination resistors. Intel's patented waveshaping technology shapes the outgoing signal to help reduce the need for external EMI filters. Four slew rate settings (refer to [Table 4 on page 14](#)) allow the designer to match the output waveform to the magnetic characteristics. On the receive side, the internal impedance is high enough that it has no practical effect on the external termination circuit.

3.2.1.2 Fault Detection and Reporting

The LXT972A supports one fault detection and reporting mechanism. “Remote Fault” refers to a MAC-to-MAC communication function that is essentially transparent to PHY layer devices. It is used only during Auto-Negotiation, and therefore is applicable only to twisted-pair links. “Far-End Fault”, on the other hand, is an optional PMA-layer function that may be embedded within PHY devices. The LXT972A supports only the Remote Fault Function, explained in the paragraph that follows.

Remote Fault

Bit 4.13 in the Auto-Negotiation Advertisement Register is reserved for Remote Fault indications. It is typically used when re-starting the auto-negotiation sequence to indicate to the link partner that the link is down because the advertising device detected a fault.

When the LXT972A receives a Remote Fault indication from its partner during auto-negotiation it:

- sets bit 5.13 in the Link Partner Base Page Ability Register, and
- sets the Remote Fault bit 1.4 in the MII Status Register to pass this information to the local controller.

3.2.2 MII Data Interface

The LXT972A supports a standard Media Independent Interface (MII). The MII consists of a data interface and a management interface. The MII Data Interface passes data between the LXT972A and a Media Access Controller (MAC). Separate parallel buses are provided for transmit and receive. This interface operates at either 10Mbps or 100Mbps. The speed is set automatically, once the operating conditions of the network link have been determined. Refer to “[MII Operation](#)” on [page 25](#) for additional details.

3.2.3 Configuration Management Interface

The LXT972A provides both an MDIO interface and a Hardware Control Interface for device configuration and management.

3.2.3.1 MDIO Management Interface

The LXT972A supports the IEEE 802.3 MII Management Interface also known as the Management Data Input/Output (MDIO) Interface. This interface allows upper-layer devices to monitor and control the state of the LXT972A. The MDIO interface consists of a physical connection, a specific protocol that runs across the connection, and an internal set of addressable registers.

Some registers are required and their functions are defined by the IEEE 802.3 standard. The LXT972A also supports additional registers for expanded functionality. The LXT972A supports multiple internal registers, each of which is 16 bits wide. Specific register bits are referenced using an “X.Y” notation, where X is the register number (0-31) and Y is the bit number (0-15).

The physical interface consists of a data line (MDIO) and clock line (MDC). Operation of this interface is controlled by the MDDIS input pin. When MDDIS is High, the MDIO read and write operations are disabled and the Hardware Control Interface provides primary configuration control. When MDDIS is Low, the MDIO port is enabled for both read and write operations and the Hardware Control Interface is not used.

MDIO Addressing

The protocol allows one controller to communicate between two LXT972A chips. Pin ADDR0 is set high or low to determine the chip address.

MDIO Frame Structure

The physical interface consists of a data line (MDIO) and clock line (MDC). The frame structure is shown in Figure 3 and Figure 4 (read and write). MDIO Interface timing is shown in Table 32 on page 53.

Figure 3. Management Interface Read Frame Structure

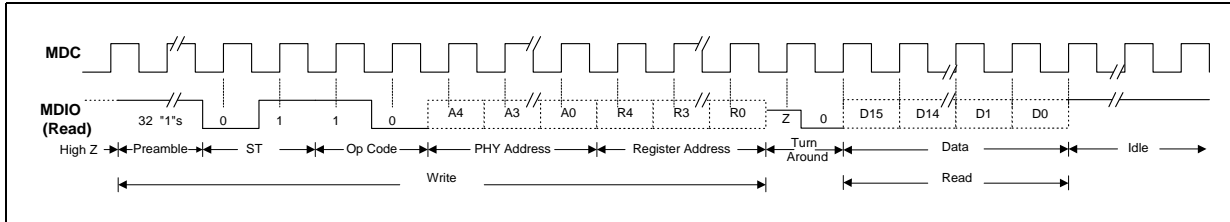
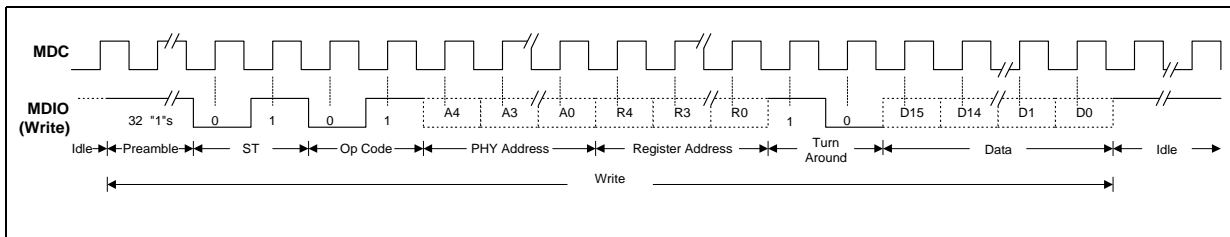

Figure 4. Management Interface Write Frame Structure



3.2.3.2 MII Interrupts

The LXT972A provides a single interrupt pin ($\overline{\text{MDINT}}$). Interrupt logic is shown in Figure 5. The LXT972A also provides two dedicated interrupt registers. Register 18 provides interrupt enable and mask functions and Register 19 provides interrupt status. Setting bit 18.1 = 1, enables the device to request interrupt via the $\overline{\text{MDINT}}$ pin. An active Low on this pin indicates a status change on the LXT972A. Interrupts may be caused by four conditions:

- Auto-negotiation complete
- Speed status change
- Duplex status change
- Link status change

3.2.3.3 Hardware Control Interface

The LXT972A provides a Hardware Control Interface for applications where the MDIO is not desired. The Hardware Control Interface uses the three LED driver pins to set device configuration. Refer to Section 3.4.5, “Hardware Configuration Settings” on page 23 for additional details.

Figure 5. Interrupt Logic

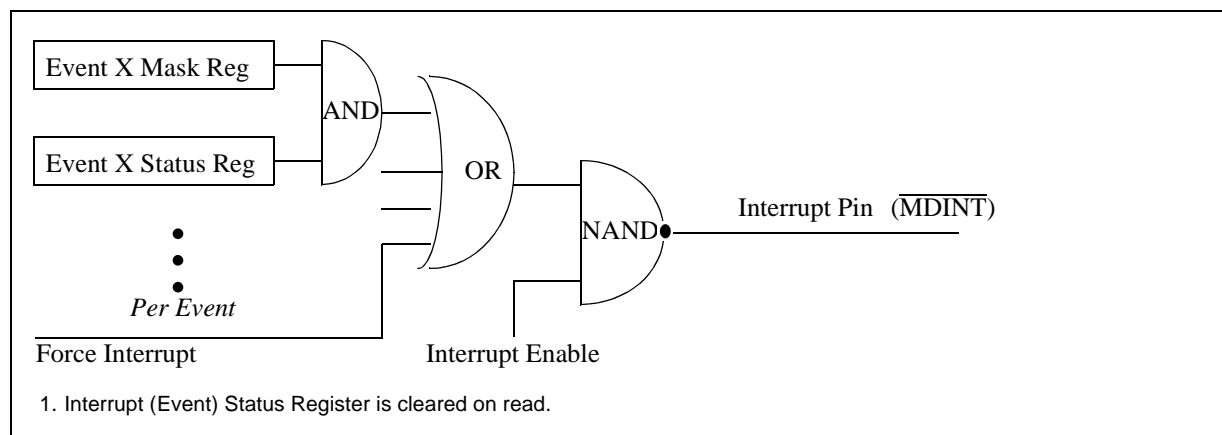

3.3 Operating Requirements

3.3.1 Power Requirements

The LXT972A requires three power supply inputs (VCCD, VCCA, and VCCIO). The digital and analog circuits require 3.3V supplies (VCCD and VCCA). These inputs may be supplied from a single source. Each supply input must be decoupled to ground.

An additional supply may be used for the MII (VCCIO). The supply may be either +2.5V or +3.3V. Also, the inputs on the MII interface are tolerant to 5V signals from the controller on the other side of the MII interface. Refer to [Table 19 on page 45](#) for MII I/O characteristics.

As a matter of good practice, these supplies should be as clean as possible.

3.3.2 Clock Requirements

3.3.2.1 External Crystal/Oscillator

The LXT972A requires a reference clock input that is used to generate transmit signals and recover receive signals. It may be provided by either of two methods: by connecting a crystal across the oscillator pins (XI and XO), or by connecting an external clock source to pin XI. The connection of a clock source to the XI pin requires the XO pin to be left open. A crystal-based clock is recommended over a derived clock (i.e., PLL-based) to minimize transmit jitter. Refer to the LXT971A/972A Design and Layout Guide for a list of recommended clock sources.

A crystal is typically used in NIC applications. An external 25 MHz clock source, rather than a crystal, is frequently used in switch applications. Refer to [Table 20 on page 45](#) for clock timing requirements.

3.3.2.2 MDIO Clock

The MII management channel (MDIO) also requires an external clock. The managed data clock (MDC) speed is a maximum of 8 MHz. Refer to [Table 32 on page 53](#) for details.

3.4 Initialization

When the LXT972A is first powered on, reset, or encounters a link failure state, it checks the MDIO register configuration bits to determine the line speed and operating conditions to use for the network link. The configuration bits may be set by the Hardware Control or MDIO interface as shown in [Figure 6](#).

3.4.1 MDIO Control Mode

In the MDIO Control mode, the LXT972A reads the Hardware Control Interface pins to set the initial (default) values of the MDIO registers. Once the initial values are set, bit control reverts to the MDIO interface.

3.4.2 Hardware Control Mode

In the Hardware Control Mode, LXT972A disables direct write operations to the MDIO registers via the MDIO Interface. On power-up or hardware reset the LXT972A reads the Hardware Control Interface pins and sets the MDIO registers accordingly.

The following modes are available using either Hardware Control or MDIO Control:

- Force network link operation to:
 - 100TX, Full-Duplex.
 - 100TX, Half-Duplex.
 - 10BASE-T, Full-Duplex.
 - 10BASE-T, Half-Duplex.
- Allow auto-negotiation / parallel-detection.

When the network link is forced to a specific configuration, the LXT972A immediately begins operating the network interface as commanded. When auto-negotiation is enabled, the LXT972A begins the auto-negotiation / parallel-detection operation.

Figure 6. Initialization Sequence

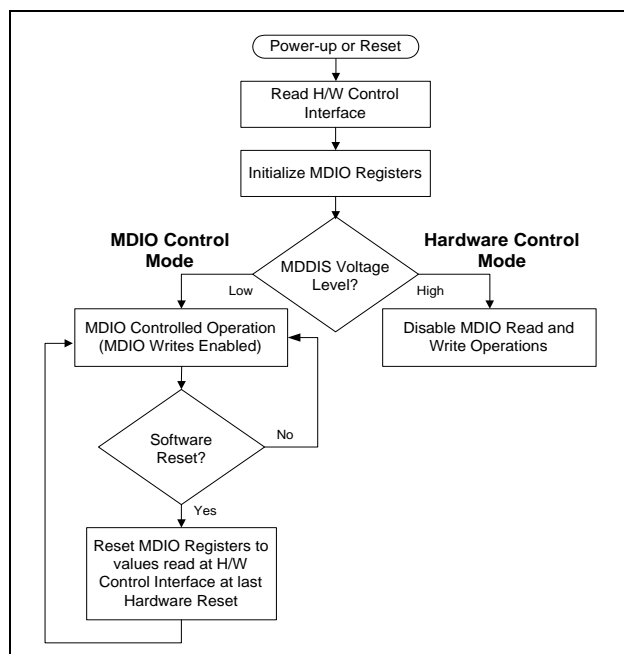

3.4.3 Reduced Power Modes

The LXT972A offers two power-down modes.

3.4.3.1 Hardware Power Down

The hardware power-down mode is controlled by the PWRDWN pin. When PWRDWN is High, the following conditions are true:

- The LXT972A network port and clock are shut down.
- All outputs are tri-stated.
- All weak pad pull-up and pull-down resistors are disabled.
- The MDIO registers are not accessible.

3.4.3.2 Software Power Down

Software power-down control is provided by bit 0.11 in the Control Register (refer to [Table 37 on page 58](#)). During soft power-down, the following conditions are true:

- The network port is shut down.
- The MDIO registers remain accessible.

3.4.4 Reset

The LXT972A provides both hardware and software resets. Configuration control of Auto-Negotiation, speed and duplex mode selection is handled differently for each. During a hardware reset, Auto-Negotiation and Speed are read in from pins (refer to [Table 8 on page 24](#) for pin settings and to [Table 37 on page 58](#) for register bit definitions).

During a software reset ($0.15 = 1$), these bit settings are not re-read from the pins. They revert back to the values that were read in during the last hardware reset. Therefore, any changes to pin values made since the last hardware reset are not detected during a software reset.

During a hardware reset, register information is unavailable for 1 ms after de-assertion of the reset. During a software reset ($0.15 = 1$) the registers are available for reading. The reset bit should be polled to see when the part has completed reset ($0.15 = 0$).

3.4.5 Hardware Configuration Settings

The LXT972A provides a hardware option to set the initial device configuration. The hardware option uses the three LED driver pins. This provides three control bits, as listed in [Table 8](#). The LED drivers can operate as either open-drain or open-source circuits as shown in [Figure 7](#).

Figure 7. Hardware Configuration Settings

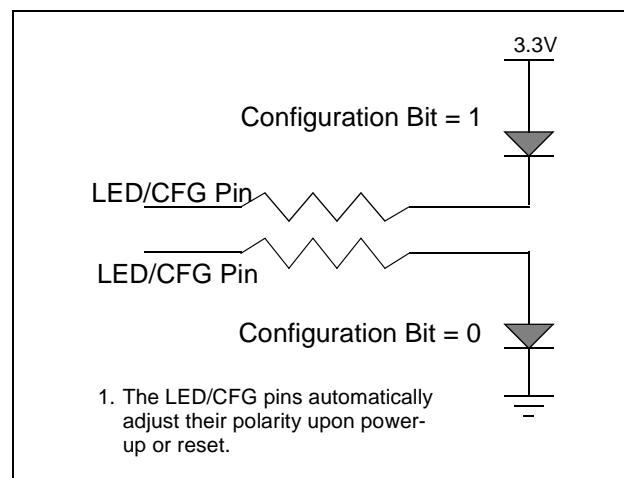

Table 8. Hardware Configuration Settings

Desired Mode			LED/CFG _n Pin Settings ¹			Resulting Register Bit Values						
						Control Register			Auto-Neg Advertisement			
Auto-Neg	Speed (Mbps)	Duplex	1	2	3	AutoNeg 0.12	Speed 0.13	FD 0.8	100FD 4.8	100TX 4.7	10FD 4.6	10T 4.5
Disabled	10	Half	Low	Low	Low	0	0	0	N/A Auto-Negotiation Advertisement			
		Full	Low	Low	High			1				
	100	Half	Low	High	Low		1	0				
		Full	Low	High	High			1				
Enabled	100 Only	Half	High	Low	Low	1	1	0	0	1	0	0
		Full	High	Low	High			1	1	1	0	0
	10/100	Half Only	High	High	Low			0	0	1	0	1
		Full or Half	High	High	High			1	1	1	1	1

1. Refer to Table 7 on page 15 for LED/CFG pin assignments.

3.5 Establishing Link

See Figure 8 for an overview of link establishment.

3.5.1 Auto-Negotiation

If not configured for forced operation, the LXT972A attempts to auto-negotiate with its link partner by sending Fast Link Pulse (FLP) bursts. Each burst consists of up to 33 link pulses spaced 62.5 μs apart. Odd link pulses (clock pulses) are always present. Even link pulses (data pulses) may be present or absent to indicate a “1” or a “0”. Each FLP burst exchanges 16 bits of data, which are referred to as a “link code word”. All devices that support auto-negotiation must implement the “Base Page” defined by IEEE 802.3 (registers 4 and 5). LXT972A also supports the optional “Next Page” function as described in Table 44 and Table 45 (registers 7 and 8).

3.5.1.1 Base Page Exchange

By exchanging Base Pages, the LXT972A and its link partner communicate their capabilities to each other. Both sides must receive at least three identical base pages for negotiation to continue. Each side identifies the highest common capabilities that both sides support and configures itself accordingly.

3.5.1.2 Next Page Exchange

Additional information, above that required by base page exchange, is also sent via “Next Pages”. The LXT972A fully supports the IEEE 802.3ab method of negotiation via Next Page exchange.

3.5.1.3 Controlling Auto-Negotiation

When auto-negotiation is controlled by software, the following steps are recommended:

- After power-up, power-down, or reset, the power-down recovery time, as specified in [Table 34 on page 54](#), must be exhausted before proceeding.
- Set the auto-negotiation advertisement register bits.
- Enable auto-negotiation (set MDIO bit 0.12 = 1).

3.5.2 Parallel Detection

For the parallel detection feature of auto-negotiation, the LXT972A also monitors for 10BASE-T Normal Link Pulses (NLP) and 100BASE-TX Idle symbols. If either is detected, the device automatically reverts to the corresponding operating mode. Parallel detection allows the LXT972A to communicate with devices that do not support auto-negotiation.

Figure 8. Link Establishment Overview

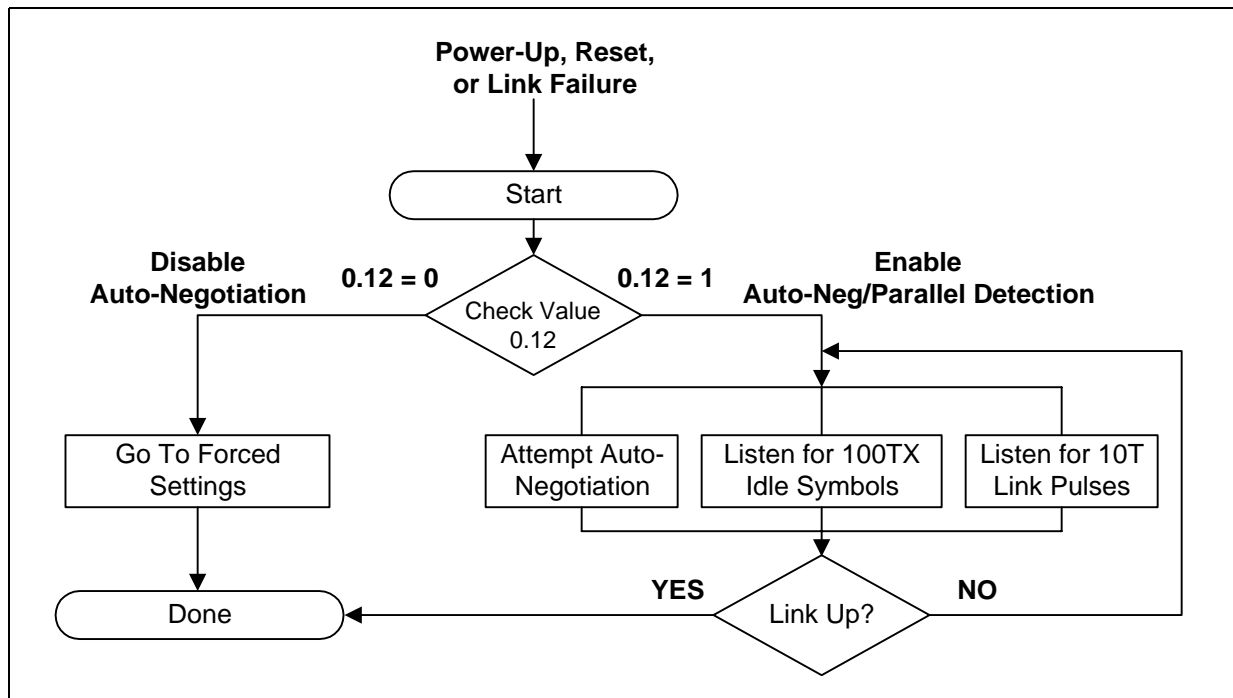

3.6 MII Operation

The LXT972A device implements the Media Independent Interface (MII) as defined in the IEEE 802.3 standard. Separate channels are provided for transmitting data from the MAC to the LXT972A (TXD), and for passing data received from the line (RXD) to the MAC. Each channel has its own clock, data bus, and control signals. Nine signals are used to pass received data to the MAC: RXD<3:0>, RX_CLK, RX_DV, RX_ER, COL, and CRS. Seven signals are used to transmit data from the MAC: TXD<3:0>, TX_CLK, TX_EN, and TX_ER.

The LXT972A supplies both clock signals as well as separate outputs for carrier sense and collision. Data transmission across the MII is normally implemented in 4-bit-wide nibbles.

3.6.1 MII Clocks

The LXT972A is the master clock source for data transmission and supplies both MII clocks (RX_CLK and TX_CLK). It automatically sets the clock speeds to match link conditions. When the link is operating at 100Mbps, the clocks are set to 25 MHz. When the link is operating at 10Mbps, the clocks are set to 2.5 MHz. [Figure 9](#) through [Figure 11](#) show the clock cycles for each mode. The transmit data and control signals must always be synchronized to TX_CLK by the MAC. The LXT972A samples these signals on the rising edge of TX_CLK.

3.6.2 Transmit Enable

The MAC must assert TX_EN the same time as the first nibble of preamble, and de-assert TX_EN after the last bit of the packet.

3.6.3 Receive Data Valid

The LXT972A asserts RX_DV when it receives a valid packet. Timing changes depend on line operating speed:

- For 100TX links, RX_DV is asserted from the first nibble of preamble to the last nibble of the data packet.
- For 10BT links, the entire preamble is truncated. RX_DV is asserted with the first nibble of the Start of Frame Delimiter (SFD) “5D” and remains asserted until the end of the packet.

3.6.4 Carrier Sense

Carrier sense (CRS) is an asynchronous output. It is always generated when a packet is received from the line and in half-duplex when a packet is transmitted.

Carrier sense is not generated when a packet is transmitted and in full-duplex mode. [Table 9](#) summarizes the conditions for assertion of carrier sense, collision, and data loopback signals.

3.6.5 Error Signals

When LXT972A is in 100Mbps mode and receives an invalid symbol from the network, it asserts RX_ER and drives “1110” on the RXD pins.

When the MAC asserts TX_ER, the LXT972A drives “H” symbols out on the TPOP/N pins.

3.6.6 Collision

The LXT972A asserts its collision signal, asynchronously to any clock, whenever the line state is half-duplex and the transmitter and receiver are active at the same time. [Table 9](#) summarizes the conditions for assertion of carrier sense, collision, and data loopback signals.

Figure 9. 10BASE-T Clocking

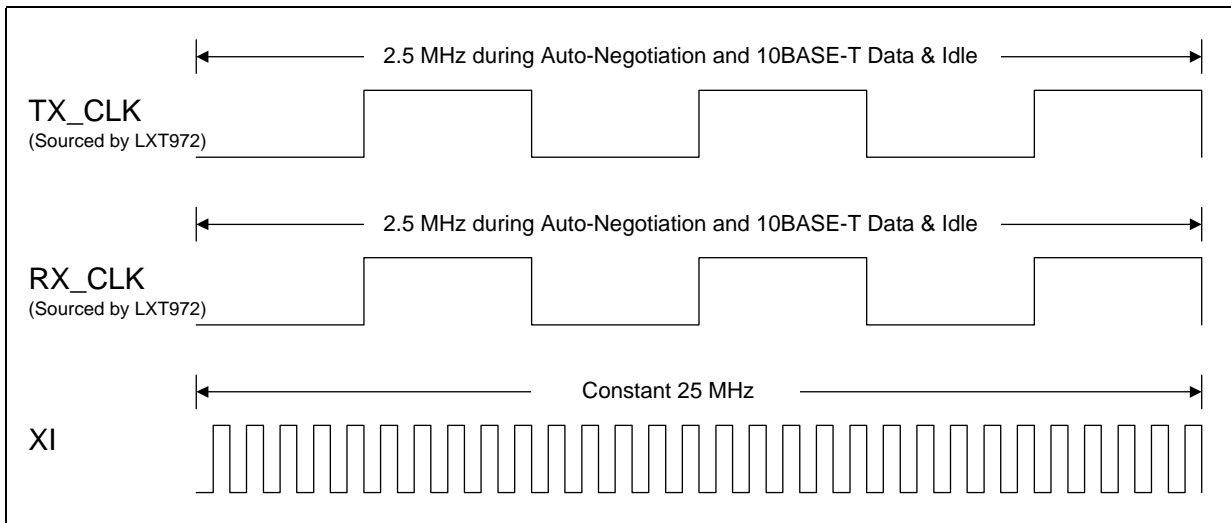

Figure 10. 100BASE-X Clocking

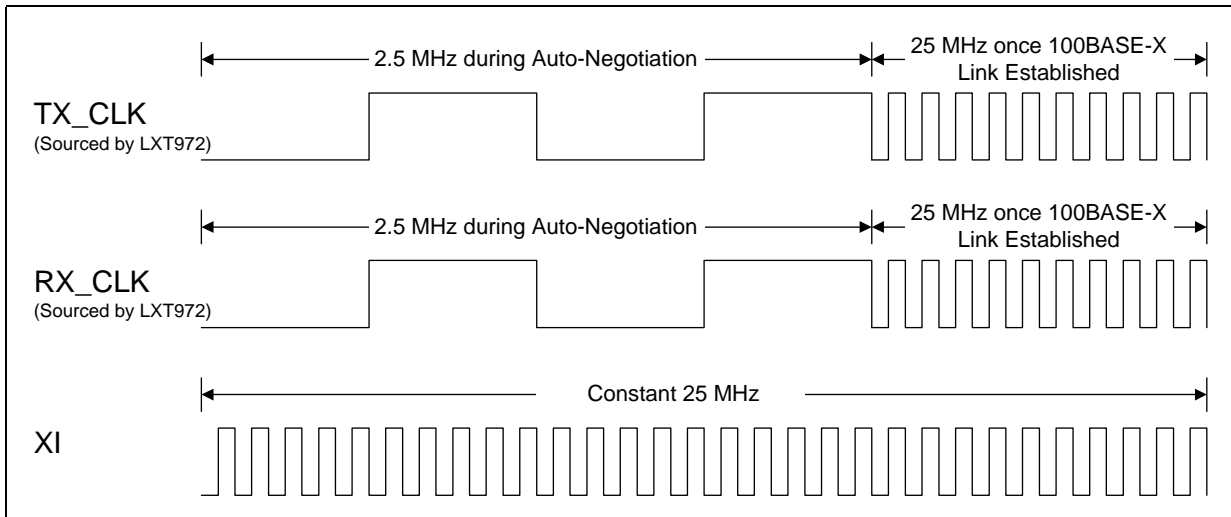
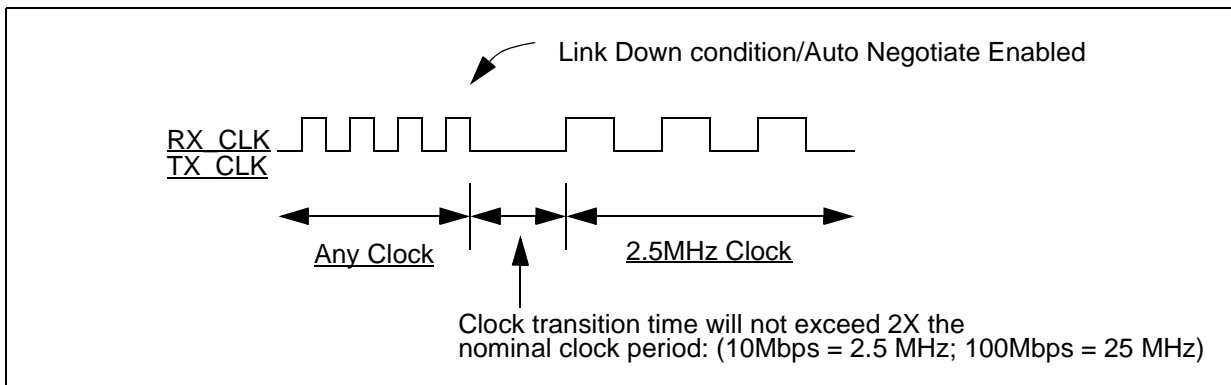

Figure 11. Link Down Clock Transition



3.6.7 Loopback

The LXT972A provides two loopback functions, operational and test (see Table 9). Loopback paths are shown in Figure 12.

3.6.7.1 Operational Loopback

Operational loopback is provided for 10Mbps half-duplex links when bit 16.8 = 0. Data transmitted by the MAC (TXData) is looped back on the receive side of the MII (RXData). Operational loopback is not provided for 100Mbps links, full-duplex links, or when 16.8 = 1.

3.6.7.2 Test Loopback

A test loopback function is provided for diagnostic testing of the LXT972A. During test loopback, the twisted-pair interface is disabled. Data transmitted by the MAC is internally looped back by the LXT972A and returned to the MAC.

Test loopback is available for both 100TX and 10T operation. Test loopback is enabled by setting bits as follows:

- 0.14 = 1
- 0.8 = 1 (full-duplex)
- 0.12 = 0 (disable auto-negotiation).

Figure 12. Loopback Paths

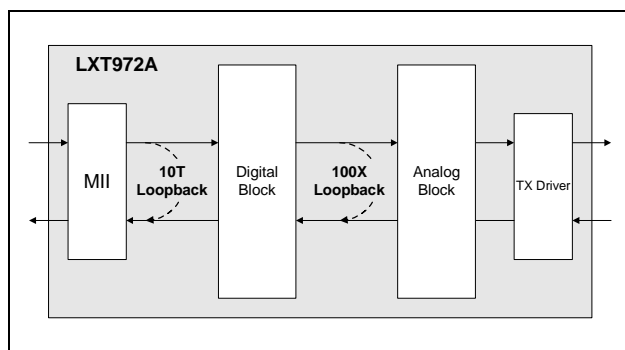

Table 9. Carrier Sense, Loopback, and Collision Conditions

Speed	Duplex Condition	Carrier Sense	Test ¹ Loopback	Operational Loopback	Collision
100Mbps	Full-Duplex	Receive Only	Yes	No	None
	Half-Duplex	Transmit or Receive	No	No	Transmit and Receive
10Mbps	Full-Duplex	Receive Only	Yes	No	None
	Half-Duplex, 16.8 = 0	Transmit or Receive	Yes	Yes	Transmit and Receive
	Half-Duplex, 16.8 = 1	Transmit or Receive	No	No	Transmit and Receive

1. Test Loopback is enabled when 0.14 = 1

3.7 100Mbps Operation

3.7.1 100BASE-X Network Operations

During 100BASE-X operation, the LXT972A transmits and receives 5-bit symbols across the network link. Figure 13 shows the structure of a standard frame packet. When the MAC is not actively transmitting data, the LXT972A sends out Idle symbols on the line.

In 100TX mode, the LXT972A scrambles and transmits the data to the network using MLT-3 line code (Figure 14 on page 29). MLT-3 signals received from the network are descrambled, decoded, and sent across the MII to the MAC.

Figure 13. 100BASE-X Frame Format

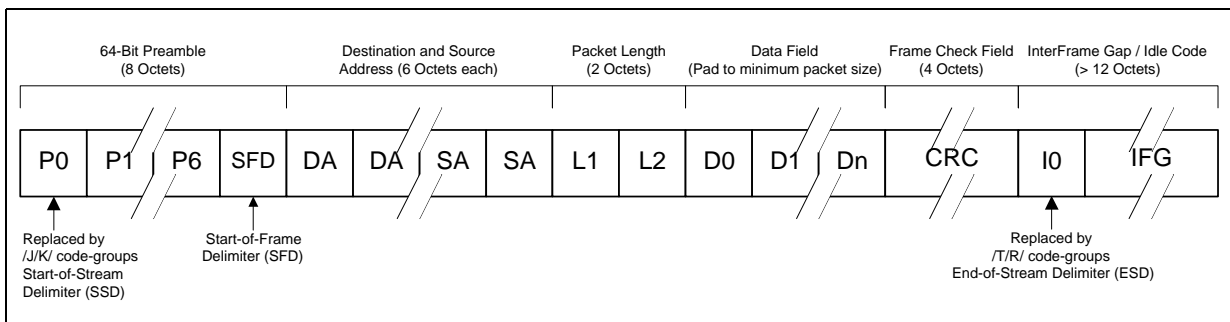
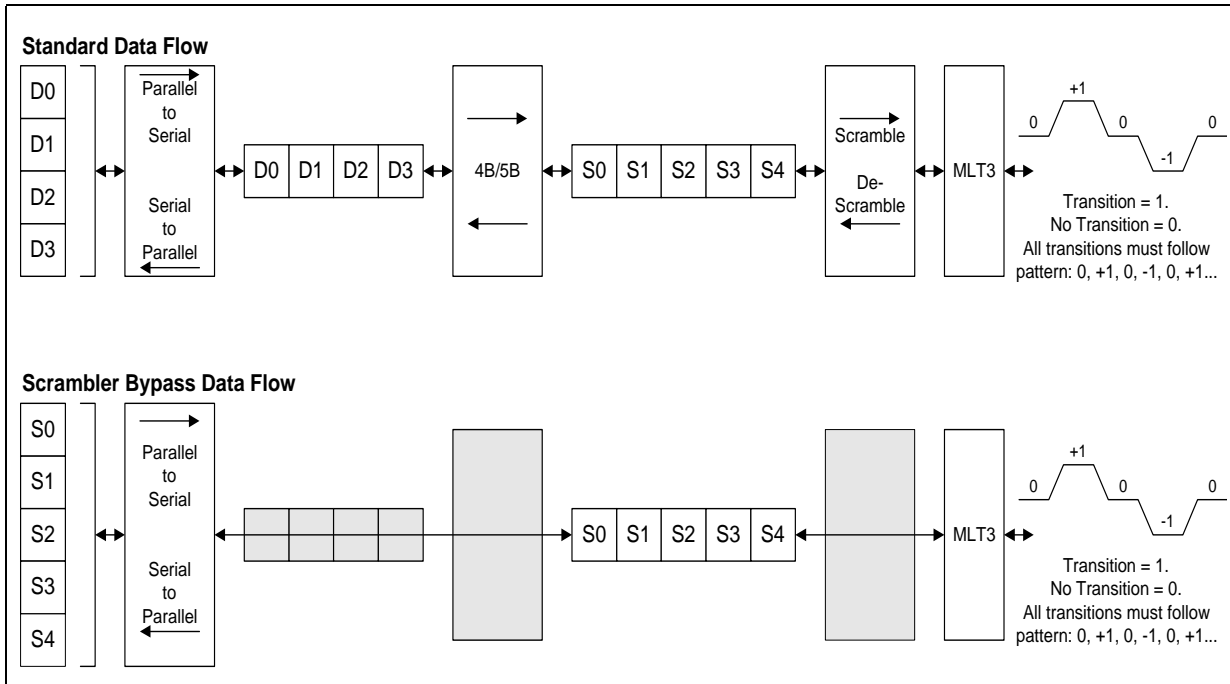

Figure 14. 100BASE-TX Data Path



As shown in [Figure 13 on page 29](#), the MAC starts each transmission with a preamble pattern. As soon as the LXT972A detects the start of preamble, it transmits a Start-of-Stream Delimiter (SSD, symbols J and K) to the network. It then encodes and transmits the rest of the packet, including the balance of the preamble, the SFD, packet data, and CRC.

Once the packet ends, the LXT972A transmits the End-of Stream-Delimiter (ESD, symbols T and R) and then returns to transmitting Idle symbols. 4B/5B coding is shown in [Table 10 on page 33](#).

[Figure 15](#) shows normal reception with no errors. When the LXT972A receives invalid symbols from the line, it asserts `RX_ER` as shown in [Figure 16](#).

Figure 15. 100BASE-TX Reception with no Errors

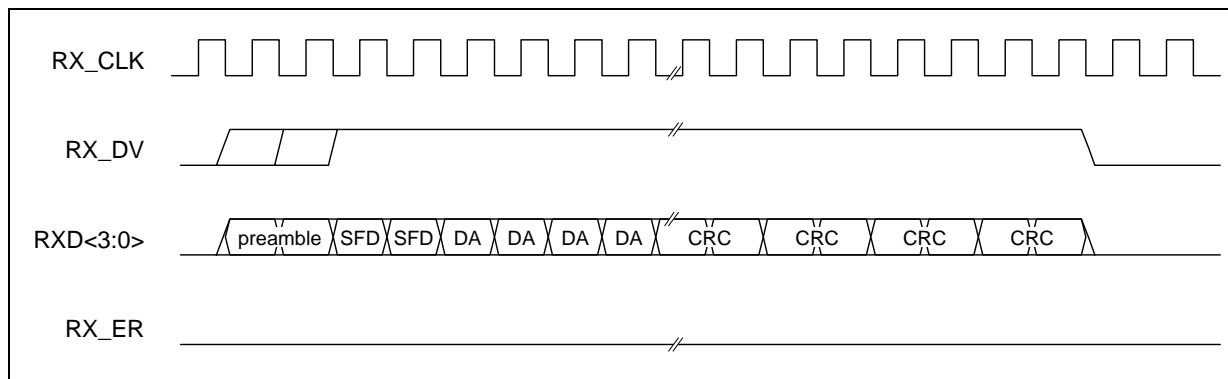
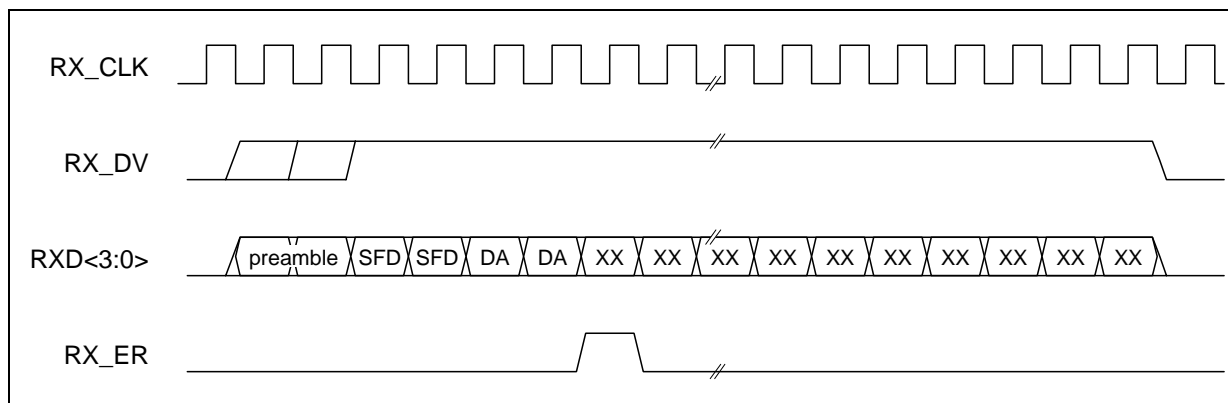

Figure 16. 100BASE-TX Reception with Invalid Symbol



3.7.2 Collision Indication

Figure 17 shows normal transmission. Upon detection of a collision, the COL output is asserted and remains asserted for the duration of the collision as shown in Figure 18.

Figure 17. 100BASE-TX Transmission with no Errors

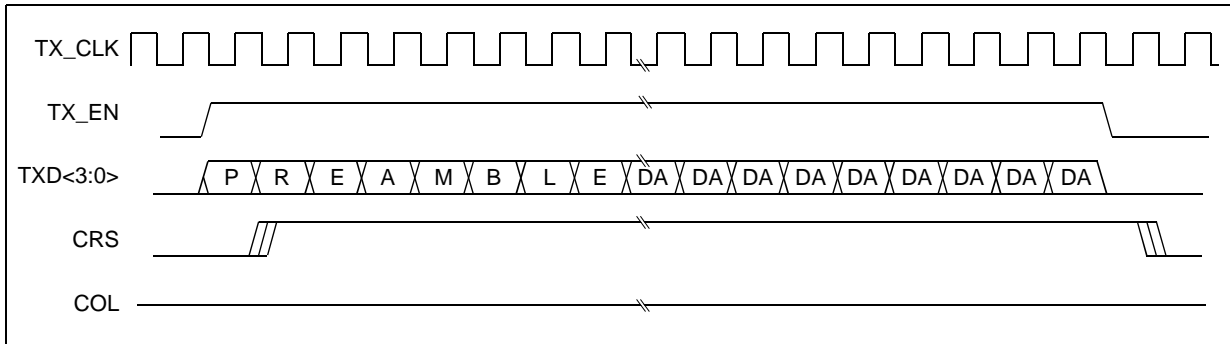
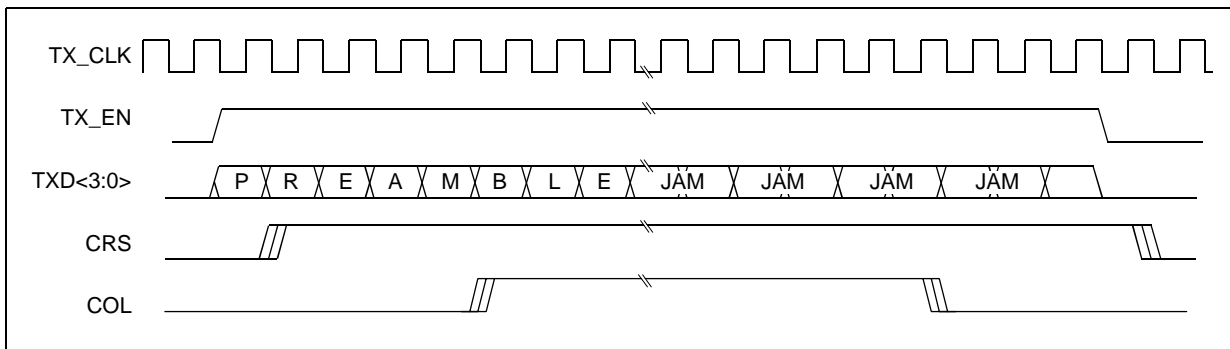

Figure 18. 100BASE-TX Transmission with Collision



3.7.3 100BASE-X Protocol Sublayer Operations

With respect to the 7-layer communications model, the LXT972A is a Physical Layer 1 (PHY) device. The LXT972A implements the Physical Coding Sublayer (PCS), Physical Medium Attachment (PMA), and Physical Medium Dependent (PMD) sublayers of the reference model defined by the IEEE 802.3u standard. The following paragraphs discuss LXT972A operation from the reference model point of view.

3.7.3.1 PCS Sublayer

The Physical Coding Sublayer (PCS) provides the MII interface, as well as the 4B/5B encoding/decoding function.

For 100TX operation, the PCS layer provides IDLE symbols to the PMD-layer line driver as long as TX_EN is de-asserted.

Preamble Handling

When the MAC asserts TX_EN, the PCS substitutes a *J/K* symbol pair, also known as the Start-of-Stream Delimiter (SSD), for the first two nibbles received across the MII. The PCS layer continues to encode the remaining MII data, following the coding in [Table 10 on page 33](#), until TX_EN is de-asserted. It then returns to supplying IDLE symbols to the line driver.

In the receive direction, the PCS layer performs the opposite function, substituting two preamble nibbles for the SSD.

Dribble Bits

The LXT972A handles dribbles bits in all modes. If between one through four dribble bits are received, the nibble is passed across the MII, padded with 1s if necessary. If between five through seven dribble bits are received, the second nibble is not sent onto the MII bus.

Figure 19. Protocol Sublayers

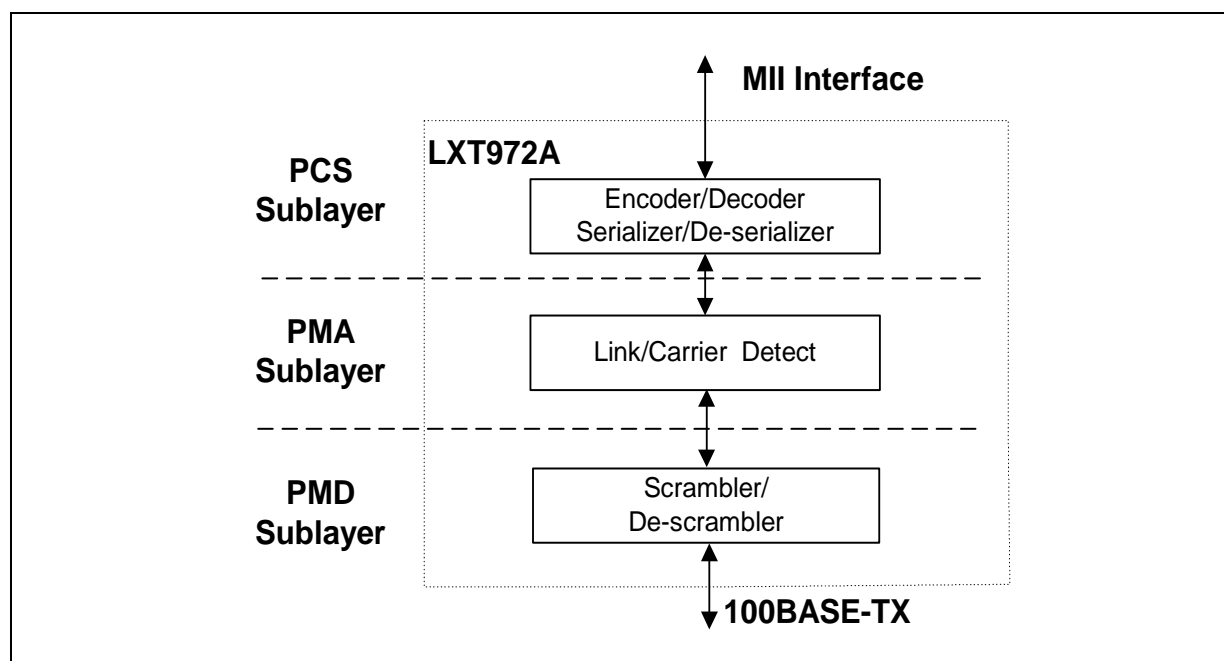

Table 10. 4B/5B Coding

Code Type	4B Code 3 2 1 0	Name	5B Code 4 3 2 1 0	Interpretation
	0 0 0 0	0	1 1 1 1 0	Data 0
	0 0 0 1	1	0 1 0 0 1	Data 1
	0 0 1 0	2	1 0 1 0 0	Data 2
	0 0 1 1	3	1 0 1 0 1	Data 3
	0 1 0 0	4	0 1 0 1 0	Data 4
	0 1 0 1	5	0 1 0 1 1	Data 5
	0 1 1 0	6	0 1 1 1 0	Data 6
DATA	0 1 1 1	7	0 1 1 1 1	Data 7
	1 0 0 0	8	1 0 0 1 0	Data 8
	1 0 0 1	9	1 0 0 1 1	Data 9
	1 0 1 0	A	1 0 1 1 0	Data A
	1 0 1 1	B	1 0 1 1 1	Data B
	1 1 0 0	C	1 1 0 1 0	Data C
	1 1 0 1	D	1 1 0 1 1	Data D
	1 1 1 0	E	1 1 1 0 0	Data E
	1 1 1 1	F	1 1 1 0 1	Data F
IDLE	undefined	I ¹	1 1 1 1 1	Idle. Used as inter-stream fill code
	0 1 0 1	J ²	1 1 0 0 0	Start-of-Stream Delimiter (SSD), part 1 of 2
CONTROL	0 1 0 1	K ²	1 0 0 0 1	Start-of-Stream Delimiter (SSD), part 2 of 2
	undefined	T ³	0 1 1 0 1	End-of-Stream Delimiter (ESD), part 1 of 2
	undefined	R ³	0 0 1 1 1	End-of-Stream Delimiter (ESD), part 2 of 2
	undefined	H ⁴	0 0 1 0 0	Transmit Error. Used to force signaling errors
	undefined	Invalid	0 0 0 0 0	Invalid
	undefined	Invalid	0 0 0 0 1	Invalid
	undefined	Invalid	0 0 0 1 0	Invalid
INVALID	undefined	Invalid	0 0 0 1 1	Invalid
	undefined	Invalid	0 0 1 0 1	Invalid
	undefined	Invalid	0 0 1 1 0	Invalid
	undefined	Invalid	0 1 0 0 0	Invalid
	undefined	Invalid	0 1 1 0 0	Invalid
	undefined	Invalid	1 0 0 0 0	Invalid
	undefined	Invalid	1 1 0 0 1	Invalid

1. The /I/ (Idle) code group is sent continuously between frames.
 2. The /J/ and /K/ (SSD) code groups are always sent in pairs; /K/ follows /J/.
 3. The /T/ and /R/ (ESD) code groups are always sent in pairs; /R/ follows /T/.
 4. An /H/ (Error) code group is used to signal an error condition.

3.7.3.2 PMA Sublayer

Link

In 100Mbps mode, the LXT972A establishes a link whenever the scrambler becomes locked and remains locked for approximately 50ms. Whenever the scrambler loses lock (receiving less than 12 consecutive idle symbols during a 2ms window), the link are taken down. This provides a very robust link, essentially filtering out any small noise hits that may otherwise disrupt the link. Furthermore, 100M idle patterns will not bring up a 10M link.

The LXT972A reports link failure via the MII status bits (1.2 and 17.10) and interrupt functions. If auto-negotiation is enabled, link failure causes the LXT972A to re-negotiate.

Link Failure Override

The LXT972A normally transmits data packets only if it detects the link is up. Setting bit 16.14 = 1 overrides this function, allowing the LXT972A to transmit data packets even when the link is down. This feature is provided as a diagnostic tool. Note that auto-negotiation must be disabled to transmit data packets in the absence of link. If auto-negotiation is enabled, the LXT972A automatically transmits FLP bursts if the link is down.

Carrier Sense

For 100TX links, a start-of-stream delimiter (SSD) or /J/K symbol pair causes assertion of carrier sense (CRS). An end-of-stream delimiter (ESD) or /T/R symbol pair causes de-assertion of CRS. The PMA layer also de-asserts CRS if IDLE symbols are received without /T/R; however, in this case RX_ER is asserted for one clock cycle when CRS is de-asserted.

Usage of CRS for Interframe Gap (IFG) timing is *not* recommended for the following reasons:

- De-assertion time for CRS is slightly longer than assertion time. This causes IFG intervals to appear somewhat shorter to the MAC than it actually is on the wire.
- CRS de-assertion is not aligned with TX_EN de-assertion on transmit loopbacks in half-duplex mode.

Receive Data Valid

The LXT972A asserts RX_DV to indicate that the received data maps to valid symbols. However, RXD outputs zeros until the received data is decoded and available for transfer to the controller.

3.7.3.3 Twisted-Pair PMD Sublayer

The twisted-pair Physical Medium Dependent (PMD) layer provides the signal scrambling and descrambling, line coding and decoding (MLT-3 for 100TX, Manchester for 10T), as well as receiving, polarity correction, and baseline wander correction functions.

Scrambler/Descrambler

The purpose of the scrambler is to spread the signal power spectrum and further reduce EMI using an 11-bit, data-independent polynomial. The receiver automatically decodes the polynomial whenever IDLE symbols are received.

Scrambler Seeding. Once the transmit data (or Idle symbols) are properly encoded, they are scrambled to further reduce EMI and to spread the power spectrum using an 11-bit scrambler seed. Five seed bits are determined by the PHY address, and the remaining bits are hard coded in the design.

Scrambler Bypass. The scrambler/descrambler can be bypassed by setting bit 16.12 = 1. Scrambler bypass is provided for diagnostic and test support.

Baseline Wander Correction

The LXT972A provides a baseline wander correction function which makes the device robust under all network operating conditions. The MLT3 coding scheme used in 100BASE-TX is by definition “unbalanced”. This means that the average value of the signal voltage can “wander” significantly over short time intervals (tenths of seconds). This wander can cause receiver errors at long-line lengths (100 meters) in less robust designs. Exact characteristics of the wander are completely data dependent.

The LXT972A baseline wander correction characteristics allow the device to recover error-free data while receiving worst-case “killer” packets over all cable lengths.

Polarity Correction

The 100BASE-TX descrambler automatically detects and corrects for the condition where the receive signal at TPIP and TPIN is inverted.

Programmable Slew Rate Control

The LXT972A device supports a slew rate mechanism whereby one of four pre-selected slew rates can be used. This allows the designer to optimize the output waveform to match the characteristics of the magnetics. The slew rate is determined by the TxSLEW pins as shown in [Table 4 on page 14](#).

3.8 10Mbps Operation

The LXT972A operates as a standard 10BASE-T transceiver. The LXT972A supports all the standard 10Mbps functions. During 10BASE-T (10T) operation, the LXT972A transmits and receives Manchester-encoded data across the network link. When the MAC is not actively transmitting data, the LXT972A drives link pulses onto the line.

In 10T mode, the polynomial scrambler/descrambler is inactive. Manchester-encoded signals received from the network are decoded by the LXT972A and sent across the MII to the MAC.

3.8.1 10T Preamble Handling

The LXT972A offers two options for preamble handling, selected by bit 16.5. In 10T Mode when 16.5 = 0, the LXT972A strips the entire preamble off of received packets. CRS is asserted coincident with SFD. RX_DV is held Low for the duration of the preamble. When RX_DV is asserted, the very first two nibbles driven by the LXT972A are the SFD “5D” hex followed by the body of the packet.

In 10T mode with $16.5 = 1$, the LXT972A passes the preamble through the MII and asserts RX_DV and CRS simultaneously. In 10T loopback, the LXT972A loops back whatever the MAC transmits to it, including the preamble.

3.8.2 10T Carrier Sense

For 10T links, CRS assertion is based on reception of valid preamble, and de-assertion on reception of an end-of-frame (EOF) marker. Bit 16.7 allows CRS de-assertion to be synchronized with RX_DV de-assertion. Refer to [Table 46 on page 64](#).

3.8.3 10T Dribble Bits

The LXT972A device handles dribbles bits in all modes. If between one through four dribble bits are received, the nibble is passed across the MII, padded with 1s if necessary. If between five through seven dribble bits are received, the second nibble is not sent onto the MII bus.

3.8.4 10T Link Integrity Test

In 10T mode, the LXT972A always transmits link pulses. When the Link Integrity Test function is enabled (the normal configuration), it monitors the connection for link pulses. Once link pulses are detected, data transmission is enabled and remains enabled as long as either the link pulses or data transmission continue. If the link pulses stop, the data transmission is disabled.

If the Link Integrity Test function is disabled, the LXT972A transmits to the connection regardless of detected link pulses. The Link Integrity Test function can be disabled by setting bit $16.14 = 1$.

3.8.4.1 Link Failure

Link failure occurs if Link Integrity Test is enabled and link pulses or packets stop being received. If this condition occurs, the LXT972A returns to the auto-negotiation phase if auto-negotiation is enabled. If the Link Integrity Test function is disabled by setting $16.14 = 1$ in the Configuration Register, the LXT972A transmits packets, regardless of link status.

3.8.5 10T SQE (Heartbeat)

By default, the Signal Quality Error (SQE) or heartbeat function is disabled on the LXT972A. To enable this function, set bit $16.9 = 1$. When this function is enabled, the LXT972A asserts its COL output for 5-15 BT after each packet. See [Figure 29 on page 51](#) for SQE timing parameters.

3.8.6 10T Jabber

If a transmission exceeds the jabber timer, the LXT972A disables the transmit and loopback functions. See [Figure 28 on page 51](#) for jabber timing parameters.

The LXT972A automatically exits jabber mode after the unjabber time has expired. This function can be disabled by setting bit $16.10 = 1$.

3.8.7 10T Polarity Correction

The LXT972A automatically detects and corrects for the condition where the receive signal (TPIP/N) is inverted. Reversed polarity is detected if eight inverted link pulses, or four inverted end-of-frame (EOF) markers, are received consecutively. If link pulses or data are not received by the maximum receive time-out period (96-128 ms), the polarity state is reset to a non-inverted state.

3.9 Monitoring Operations

3.9.1 Monitoring Auto-Negotiation

Auto-negotiation can be monitored as follows:

- Bit 17.7 is set to 1 once the Auto-Negotiation process is completed.
- Bits 1.2 and 17.10 are set to 1 once the link is established.
- Bits 17.14 and 17.9 can be used to determine the link operating conditions (speed and duplex).

3.9.1.1 Monitoring Next Page Exchange

The LXT972A offers an Alternate Next Page mode to simplify the next page exchange process. Normally, bit 6.1 (Page Received) remains set until read. When Alternate Next Page mode is enabled (16.1 = 1), bit 6.1 is automatically cleared whenever a new negotiation process takes place. This prevents the user from reading an old value in 6.1 and assuming that Registers 5 and 8 (Partner Ability) contain valid information. Additionally, the LXT972A uses bit 6.5 to indicate when the current received page is the base page. This information is useful for recognizing when next pages must be resent due to a new negotiation process starting. Bits 6.1 and 6.5 are cleared when read.

3.9.2 LED Functions

The LXT972A incorporates three direct LED drivers. On power up all the drivers are asserted for approximately 1 second after reset de-asserts. Each LED driver can be programmed using the LED Configuration Register (refer to [Table 50 on page 68](#)) to indicate one the following conditions:

- Operating Speed
- Transmit Activity
- Receive Activity
- Collision Condition
- Link Status
- Duplex Mode

The LED drivers can also be programmed to display various combined status conditions. For example, setting bits 20.15:12 = 1101 produces the following combination of Link and Activity indications:

- If Link is down LED is off.
- If Link is up LED is on.

- If Link is up and activity is detected, the LED blinks at the stretch interval selected by bits 20.3:2 and continues to blink as long as activity is present.

The LED driver pins also provide initial configuration settings. The LED pins are sensitive to polarity and automatically pulls up or pulls down to configure for either open drain or open source circuits (10 mA Max current rating) as required by the hardware configuration. Refer to the discussion of “[Hardware Configuration Settings](#)” on page 23 for details.

3.9.2.1 LED Pulse Stretching

The LED Configuration Register also provides optional LED pulse stretching to 30, 60, or 100 ms. If during this pulse stretch period the event occurs again, the pulse stretch time is further extended.

When an event such as receiving a packet occurs, it is edge detected and starts the stretch timer. The LED driver remains asserted until the stretch timer expires. If another event occurs before the stretch timer expires, the stretch timer is reset and the stretch time is extended.

When a long event (such as duplex status) occurs, it is edge detected and starts the stretch timer. When the stretch timer expires the edge detector is reset so that a long event causes another pulse to be generated from the edge detector, which resets the stretch timer and causes the LED driver to remain asserted. [Figure 20](#) shows how the stretch operation functions.

Figure 20. LED Pulse Stretching

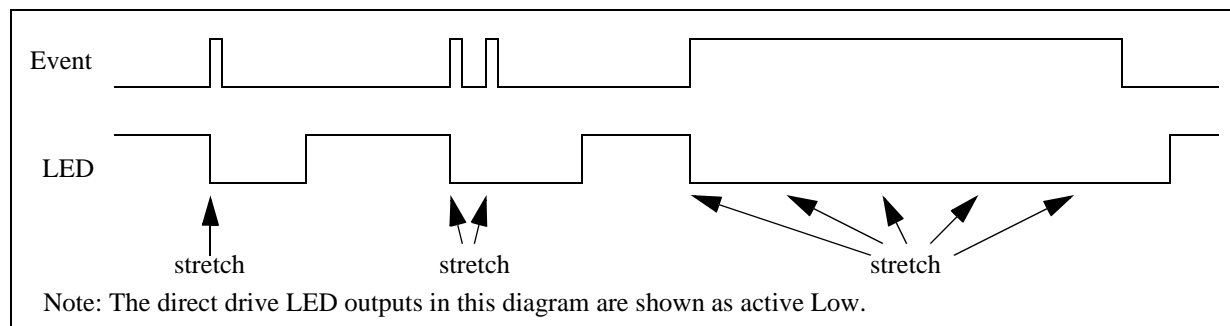

3.10 Boundary Scan (JTAG1149.1) Functions

LXT972A includes a IEEE 1149.1 boundary scan test port for board level testing. All digital input, output, and input/output pins are accessible. *The BSDL file is available by contacting your local sales office (see the back page) or by accessing the Intel web site (developer.intel.com/design/network/).*

3.10.1 Boundary Scan Interface

This interface consists of five pins (TMS, TDI, TDO, $\overline{\text{TRST}}$, and TCK). It includes a state machine, data register array, and instruction register. The TMS and TDI pins are internally pulled up. TCK is internally pulled down. TDO does not have an internal pull-up or pull-down.

3.10.2 State Machine

The TAP controller is a 16 state machine driven by the TCK and TMS pins. Upon reset the TEST_LOGIC_RESET state is entered. The state machine is also reset when TMS and TDI are high for five TCK periods.

3.10.3 Instruction Register

After the state machine resets, the IDCODE instruction is always invoked. The decode logic ensures the correct data flow to the Data registers according to the current instruction. Valid instructions are listed in Table 12.

3.10.4 Boundary Scan Register (BSR)

Each Boundary Scan Register (BSR) cell has two stages. A flip-flop and a latch are used for the serial shift stage and the parallel output stage. There are four modes of operation as listed in Table 11.

Table 11. BSR Mode of Operation

Mode	Description
1	Capture
2	Shift
3	Update
4	System Function

Table 12. Supported JTAG Instructions

Name	Code	Description	Mode	Data Register
EXTEST	0000	External Test	Test	BSR
IDCODE	0001	ID Code Inspection	Normal	ID REG
SAMPLE	0010	Sample Boundary	Normal	BSR
TRIBYP	0011	Force Float	Normal	Bypass
SETBYP	0100	Control Boundary to 1/0	Test	Bypass
BYPASS	1111	Bypass Scan	Normal	Bypass

Table 13. Device ID Register

31:28	27:12	11:8	7:1	0
Version	Part ID (hex)	JeDEC Continuation Characters	JEDEC ID ¹	Reserved
0001	03CB	1110	111 1110	1
1. The JEDEC IS is an 8-bit identifier. The MSB is for parity and is ignored. Intel's JEDEC ID is FE (1111 1110) which becomes 111 1110				

4.0 Application Information

4.1 Magnetics Information

The LXT972A requires a 1:1 ratio for both the receive and transmit transformers. The transformer isolation voltage should be rated at 2kV to protect the circuitry from static voltages across the connectors and cables. Refer to [Table 14](#) for transformer requirements.

A cross-reference list of magnetic manufacturers and part numbers is available in Application Note 073, Magnetic Manufacturers, which can be found on the Intel web site (developer.intel.com/design/network/). Before committing to a specific component, designers should contact the manufacturer for current product specifications, and validate the magnetics for the specific application.

Table 14. Magnetics Requirements

Parameter	Min	Nom	Max	Units	Test Condition
Rx turns ratio	–	1 : 1	–	–	
Tx turns ratio	–	1 : 1	–	–	
Insertion loss	0.0	0.6	1.1	dB	
Primary inductance	350	–	–	μH	
Transformer isolation	–	1.5	–	kV	
Differential to common mode rejection	40	–	–	dB	.1 to 60 MHz
	35	–	–	dB	60 to 100 MHz
Return Loss	-16	–	–	dB	30 MHz
	-10	–	–	dB	80 MHz

4.2 Typical Twisted-Pair Interface

[Table 15](#) provides a comparison of the RJ-45 connections for NIC and switch applications in a typical twisted-pair interface setting.

Table 15. RJ-45 Pin Comparison of NIC and Switch Twisted-Pair Interfaces

Symbol	RJ-45	
	Switch	NIC
TPIP	1	3
TPIN	2	6
TPOP	3	1
TPON	6	2

[Figure 21 on page 41](#) shows a typical twisted-pair interface with the RJ-45 connections crossed over for a switch configuration. [Figure 22 on page 42](#) provides a typical twisted-pair interface with the RJ-45 connections configured for a NIC application.

Figure 21. Typical Twisted-Pair Interface - Switch

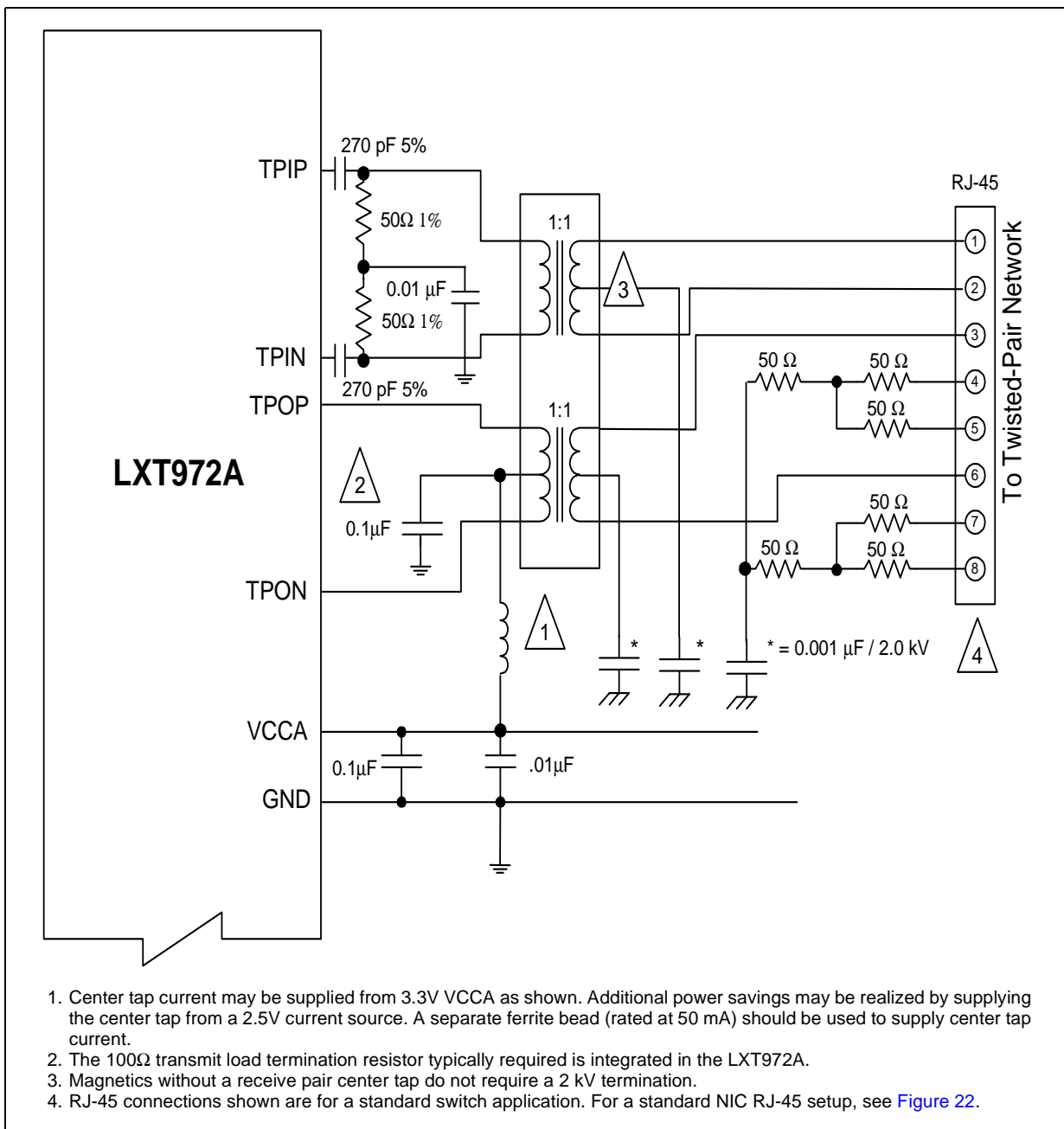

Figure 22. Typical Twisted-Pair Interface - NIC

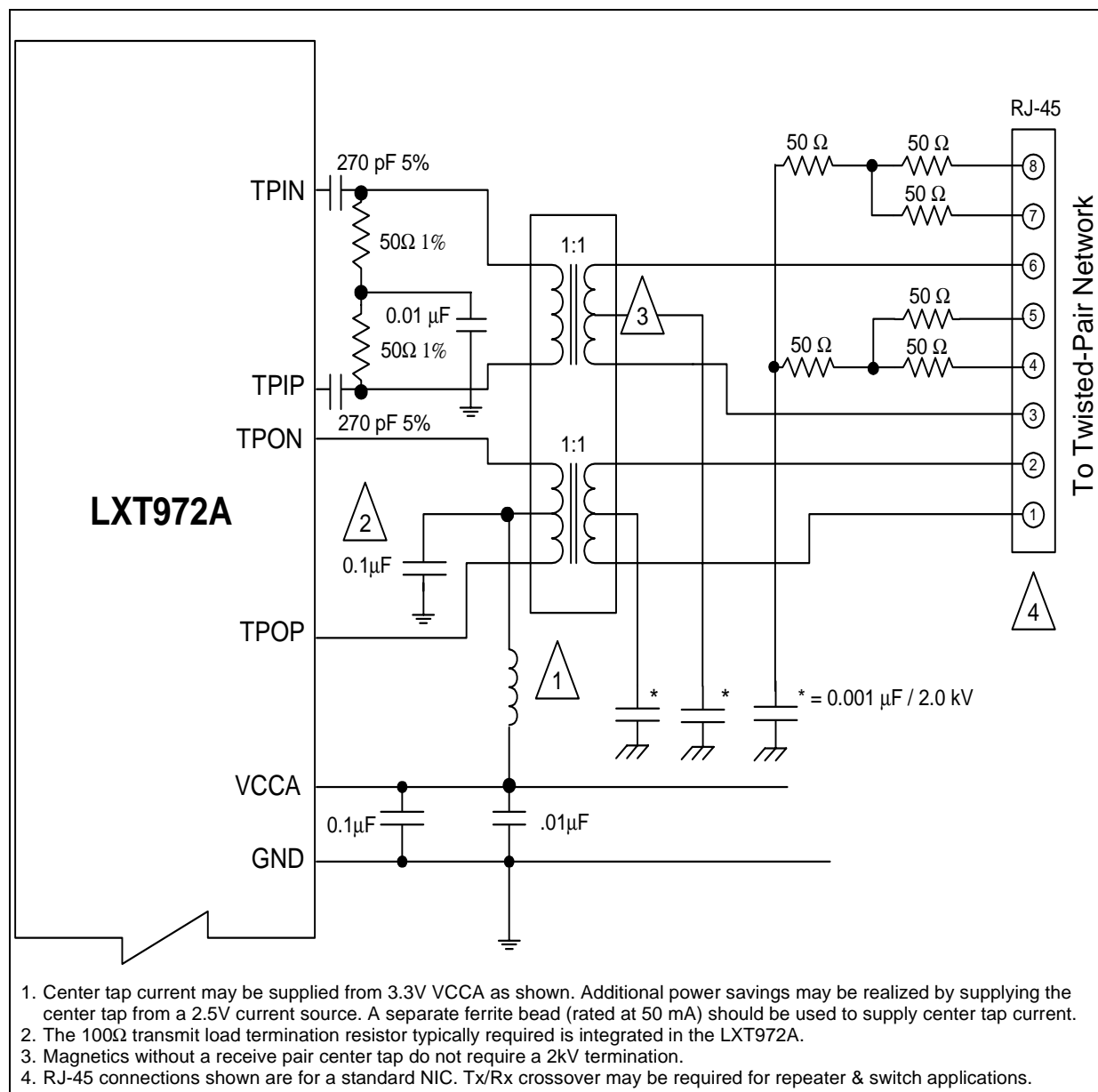
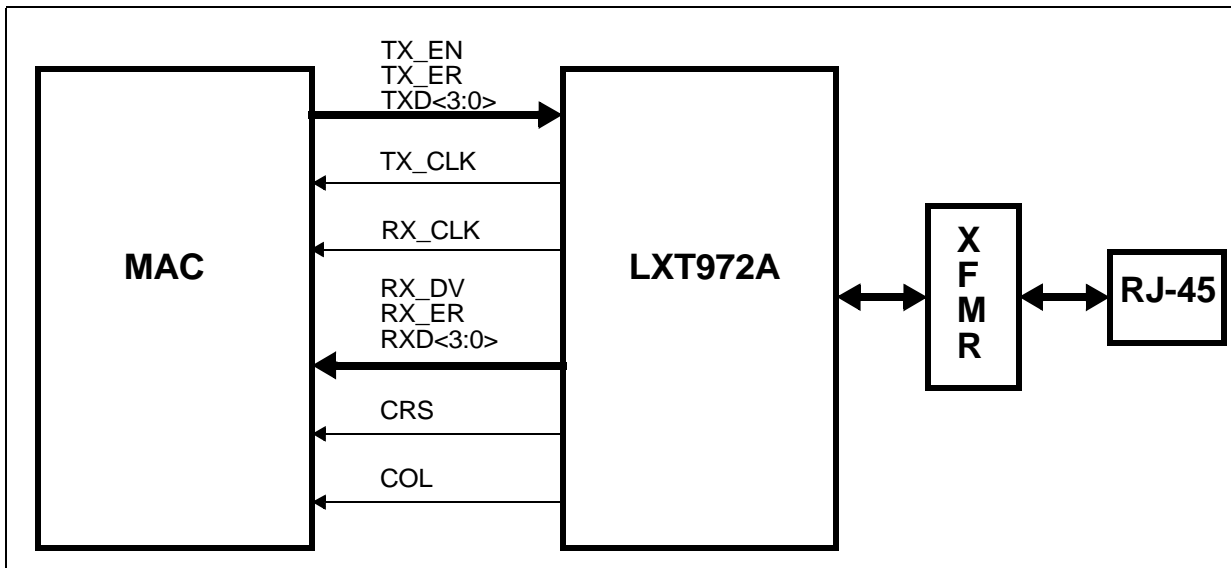

Figure 23. Typical MII Interface



5.0 Test Specifications

Note: Table 16 through Table 34 and Figure 24 through Figure 35 represent the target specifications of the LXT972A. These specifications are guaranteed by test except where noted “by design.” Minimum and maximum values listed in Table 18 through Table 34 apply over the recommended operating conditions specified in Table 17.

5.1 Electrical Parameters

Table 16. Absolute Maximum Ratings

Parameter	Sym	Min	Max	Units
Supply voltage	VCC	-0.3	4.0	V
Operating temperature	TOPA	0	+70	°C
Storage temperature	TST	-65	+150	°C

Caution: Exceeding these values may cause permanent damage.
Functional operation under these conditions is not implied.
Exposure to maximum rating conditions for extended periods may affect device reliability.

Table 17. Operating Conditions

Parameter		Sym	Min	Typ ¹	Max	Units
Recommended operating temperature	LXT972A_C (Commercial)	TOPA	0	–	70	°C
Recommended supply voltage ²	Analog & Digital	Vcca, Vccd	3.14	3.3	3.45	V
	I/O	Vccio	2.35	–	3.45	V
VCC current	100BASE-TX	Icc	–	–	110	mA
	10BASE-T	Icc	–	–	82	mA
	Power Down	Icc	–	–	1	mA
	Auto-Negotiation	Icc	–	–	110	mA

1. Typical values are at 25 °C and are for design aid only; not guaranteed and not subject to production testing.
2. Voltages with respect to ground unless otherwise specified.

Table 18. Digital I/O Characteristics ¹

Parameter	Symbol	Min	Typ ²	Max	Units	Test Conditions
Input Low voltage	V _{IL}	–	–	0.8	V	–
Input High voltage	V _{IH}	2.0	–	–	V	–
Input current	I _I	-10	–	10	μA	0.0 < V _I < V _{CC}
Output Low voltage	V _{OL}	–	–	0.4	V	I _{OL} = 4 mA
Output High voltage	V _{OH}	2.4	–	–	V	I _{OH} = -4 mA

1. Applies to all pins except MII, LED and XI/XO pins. Refer to [Table 19](#) for MII I/O Characteristics, [Table 20](#) for XI/XO and [Table 21](#) for LED Characteristics.
2. Typical values are at 25 °C and are for design aid only; not guaranteed and not subject to production testing.

Table 19. Digital I/O Characteristics - MII Pins

Parameter	Symbol	Min	Typ ¹	Max	Units	Test Conditions
Input Low voltage	V _{IL}	–	–	0.8	V	–
Input High voltage	V _{IH}	2.0	–	–	V	–
Input current	I _I	-10	–	10	μA	0.0 < V _I < V _{CCIO}
Output Low voltage	V _{OL}	–	–	0.4	V	I _{OL} = 4 mA
Output High voltage	V _{OH}	2.2	–	–	V	I _{OH} = -4 mA, V _{CCIO} = 3.3V
	V _{OH}	2.0	–	–	V	I _{OH} = -4 mA, V _{CCIO} = 2.5V
Driver output resistance (Line driver output enabled)	R _{O²}	–	100	–	Ω	V _{CCIO} = 2.5V
	R _{O²}	–	100	–	Ω	V _{CCIO} = 3.3V

1. Typical values are at 25 °C and are for design aid only; not guaranteed and not subject to production testing.
2. Parameter is guaranteed by design; not subject to production testing.

Table 20. I/O Characteristics - REFCLK/XI and XO Pins

Parameter	Sym	Min	Typ ¹	Max	Units	Test Conditions
Input Low Voltage	V _{IL}	–	–	0.8	V	
Input High Voltage	V _{IH}	2.0	–	–	V	
Input Clock Frequency Tolerance ²	Δf	–	–	±100	ppm	
Input Clock Duty Cycle ²	T _{dc}	35	–	65	%	
Input Capacitance	C _{IN}	–	3.0	–	pF	

1. Typical values are at 25 °C and are for design aid only; not guaranteed and not subject to production testing.
2. Parameter is guaranteed by design; not subject to production testing.

Table 21. I/O Characteristics - LED/CFG Pins

Parameter	Sym	Min	Typ	Max	Units	Test Conditions
Output Low Voltage	V _{ol}	–	–	0.4	V	I _{OL} = 10 mA
Output High Voltage	V _{oh}	2.4	–	–	V	I _{OH} = -10 mA
Input Current	I _I	-10	–	10	μA	0 < V _I < V _{CCIO}

Table 22. 100BASE-TX Transceiver Characteristics

Parameter	Sym	Min	Typ ¹	Max	Units	Test Conditions
Peak differential output voltage	VP	0.95	–	1.05	V	Note 2
Signal amplitude symmetry	Vss	98	–	102	%	Note 2
Signal rise/fall time	TRF	3.0	–	5.0	ns	Note 2
Rise/fall time symmetry	TRFS	–	–	0.5	ns	Note 2
Duty cycle distortion	DCD	35	50	65	%	Offset from 16ns pulse width at 50% of pulse peak
Overshoot/Undershoot	VOS	–	–	5	%	–
Jitter (measured differentially)	–	–	–	1.4	ns	–

1. Typical values are at 25 °C and are for design aid only; not guaranteed and not subject to production testing.
2. Measured at the line side of the transformer, line replaced by 100Ω(+/-1%) resistor.

Table 23. 10BASE-T Transceiver Characteristics

Parameter	Sym	Min	Typ	Max	Units	Test Conditions
Transmitter						
Peak differential output voltage	VOP	2.2	2.5	2.8	V	With transformer, line replaced by 100 Ω resistor
Transition timing jitter added by the MAU and PLS sections	-	0	2	11	ns	After line model specified by IEEE 802.3 for 10BASE-T MAU
Receiver						
Receive Input Impedance	ZIN	-	-	22	kΩ	
Differential Squelch Threshold	VDS	300	420	585	mV	

Table 24. 10BASE-T Link Integrity Timing Characteristics

Parameter	Sym	Min	Typ	Max	Units	Test Conditions
Time Link Loss Receive	TLL	50	–	150	ms	–
Link Pulse	TLP	2	–	7	Link Pulses	–
Link Min Receive Timer	TLR MIN	2	–	7	ms	–
Link Max Receive Timer	TLR MAX	50	–	150	ms	–
Link Transmit Period	Tlt	8	–	24	ms	–
Link Pulse Width	Tlpw	60	–	150	ns	–

1. Typical values are at 25 °C and are for design aid only; not guaranteed and not subject to production testing.

5.2 Timing Diagrams

Figure 24. 100BASE-TX Receive Timing - 4B Mode

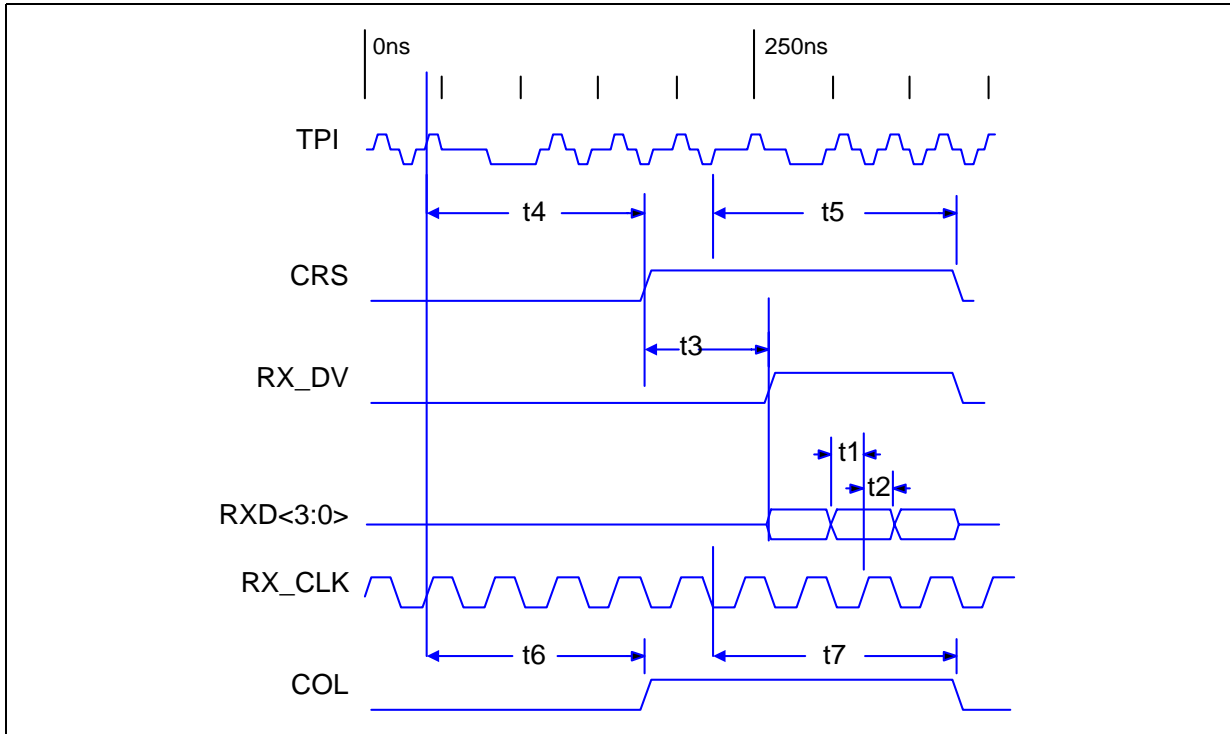

Table 25. 100BASE-TX Receive Timing Parameters - 4B Mode

Parameter	Sym	Min	Typ ¹	Max	Units ²	Test Conditions
RXD<3:0>, RX_DV, RX_ER setup to RX_CLK High	t1	10	–	–	ns	–
RXD<3:0>, RX_DV, RX_ER hold from RX_CLK High	t2	10	–	–	ns	–
CRS asserted to RXD<3:0>, RX_DV	t3	3	–	5	BT	–
Receive start of “J” to CRS asserted	t4	12	–	16	BT	–
Receive start of “T” to CRS de-asserted	t5	10	–	17	BT	–
Receive start of “J” to COL asserted	t6	16	–	22	BT	–
Receive start of “T” to COL de-asserted	t7	17	–	20	BT	–

1. Typical values are at 25 °C and are for design aid only; not guaranteed and not subject to production testing.
 2. BT is the duration of one bit as transferred to and from the MAC and is the reciprocal of the bit rate. 100BASE-T bit time = 10⁻⁸ s or 10 ns.

Figure 25. 100BASE-TX Transmit Timing - 4B Mode

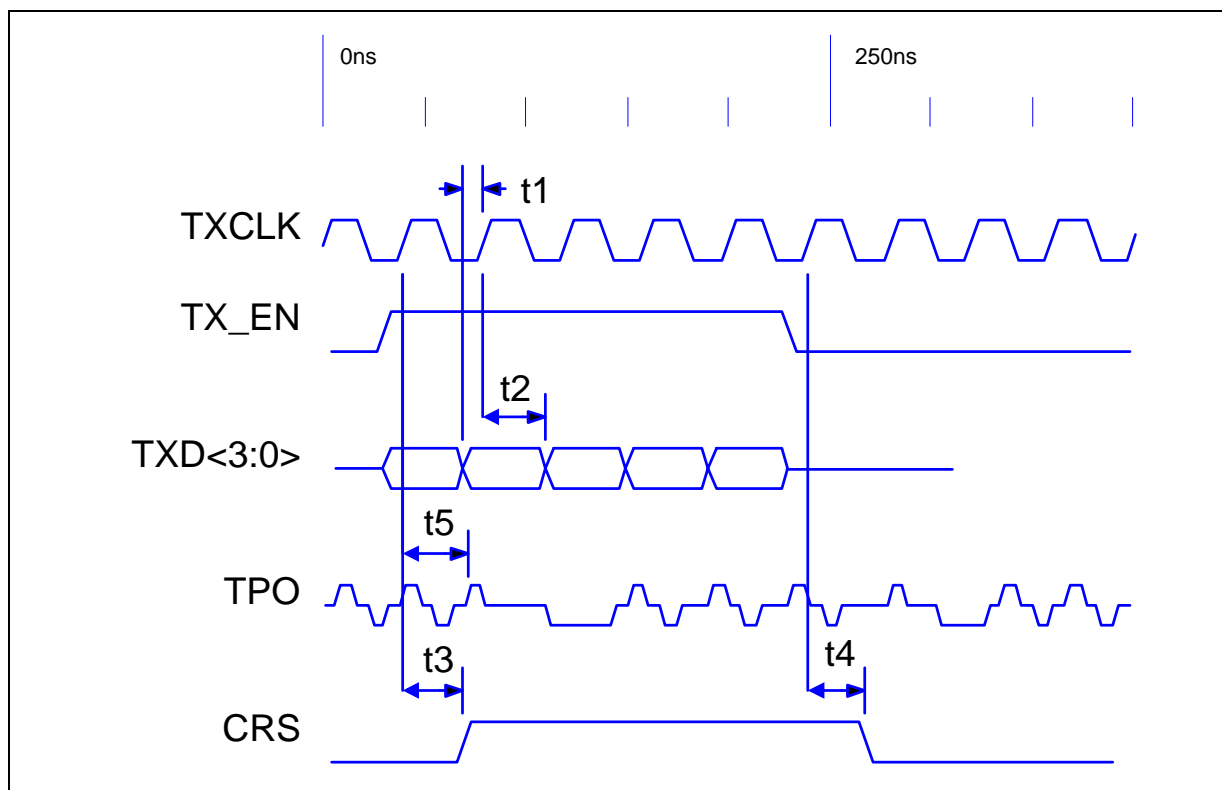

Table 26. 100BASE-TX Transmit Timing Parameters - 4B Mode

Parameter	Sym	Min	Typ ¹	Max	Units ²	Test Conditions
TXD<3:0>, TX_EN, TX_ER setup to TX_CLK High	t1	12	–	–	ns	–
TXD<3:0>, TX_EN, TX_ER hold from TX_CLK High	t2	0	–	–	ns	–
TX_EN sampled to CRS asserted	t3	20	–	24	BT	–
TX_EN sampled to CRS de-asserted	t4	24	–	28	BT	–
TX_EN sampled to TPO out (Tx latency)	t5	5.3	–	5.7	BT	–

1. Typical values are at 25 °C and are for design aid only; not guaranteed and not subject to production testing.
 2. BT is the duration of one bit as transferred to and from the MAC and is the reciprocal of the bit rate. 100BASE-T bit time = 10⁻⁸ s or 10 ns.

Figure 26. 10BASE-T Receive Timing

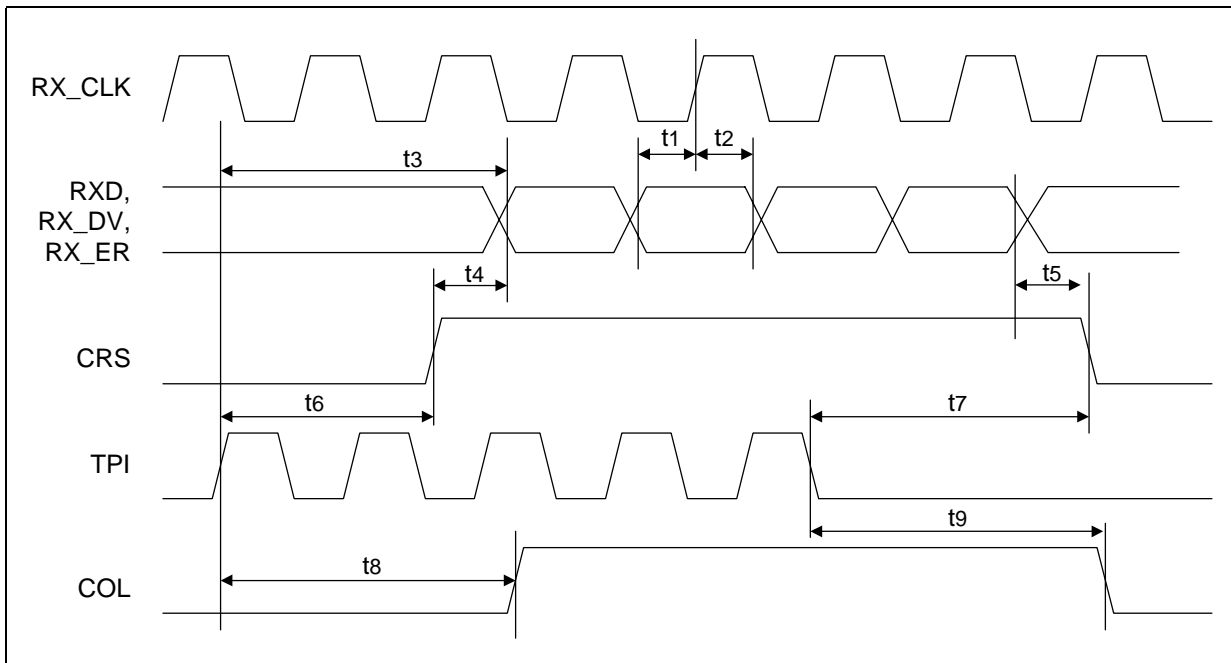

Table 27. 10BASE-T Receive Timing Parameters

Parameter	Sym	Min	Typ ¹	Max	Units ²	Test Conditions
RXD, RX_DV, RX_ER Setup to RX_CLK High	t1	10	–	–	ns	–
RXD, RX_DV, RX_ER Hold from RX_CLK High	t2	10	–	–	ns	–
TPIP/N in to RXD out (Rx latency)	t3	5.8	–	6.0	BT	–
CRS asserted to RXD, RX_DV, RX_ER asserted	t4	5	–	32	BT	–
RXD, RX_DV, RX_ER de-asserted to CRS de-asserted	t5	0.3	–	0.5	BT	–
TPI in to CRS asserted	t6	2	–	28	BT	–
TPI quiet to CRS de-asserted	t7	6	–	10	BT	–
TPI in to COL asserted	t8	1	–	31	BT	–
TPI quiet to COL de-asserted	t9	5	–	10	BT	–

1. Typical values are at 25 °C and are for design aid only; not guaranteed and not subject to production testing.
 2. BT is the duration of one bit as transferred to and from the MAC and is the reciprocal of the bit rate. 10BASE-T bit time = 10⁻⁷ s or 100 ns.

Figure 27. 10BASE-T Transmit Timing

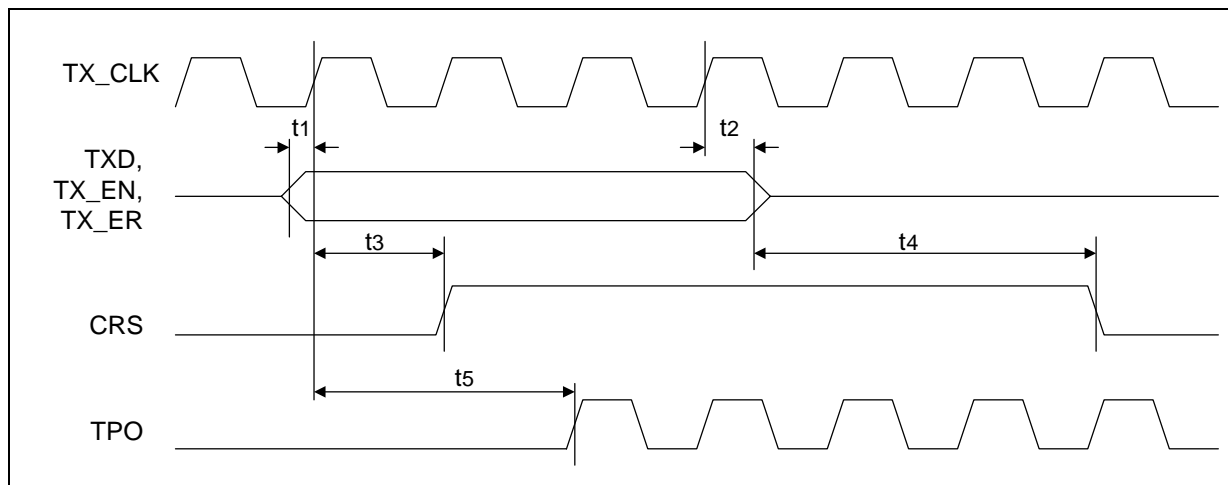

Table 28. 10BASE-T Transmit Timing Parameters

Parameter	Sym	Min	Typ ¹	Max	Units ²	Test Conditions
TXD, TX_EN, TX_ER setup to TX_CLK High	t1	10	–	–	ns	–
TXD, TX_EN, TX_ER hold from TX_CLK High	t2	0	–	–	ns	–
TX_EN sampled to CRS asserted	t3	–	2	–	BT	–
TX_EN sampled to CRS de-asserted	t4	–	1	–	BT	–
TX_EN sampled to TPO out (Tx latency)	t5	–	72.5	–	BT	–

1. Typical values are at 25 °C and are for design aid only; not guaranteed and not subject to production testing.
 2. BT is the duration of one bit as transferred to and from the MAC and is the reciprocal of the bit rate. 10BASE-T bit time = 10^{-7} s or 100 ns.

Figure 28. 10BASE-T Jabber and Unjabber Timing

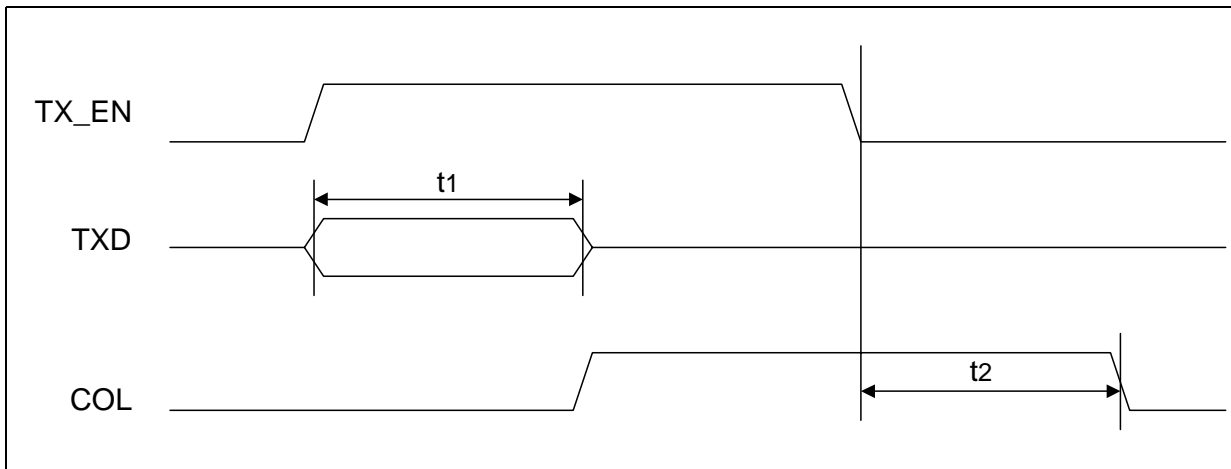

Table 29. 10BASE-T Jabber and Unjabber Timing Parameters

Parameter	Sym	Min	Typ ¹	Max	Units	Test Conditions
Maximum transmit time	t1	20	–	150	ms	–
Unjab time	t2	250	–	750	ms	–

1. Typical values are at 25 °C and are for design aid only; not guaranteed and not subject to production testing.

Figure 29. 10BASE-T SQE (Heartbeat) Timing

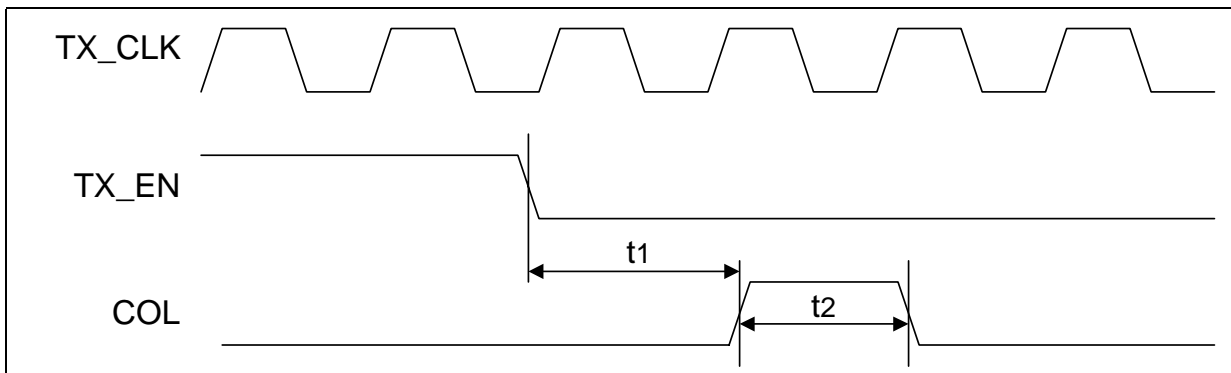

Table 30. 10BASE-T SQE Timing Parameters

Parameter	Sym	Min	Typ ¹	Max	Units	Test Conditions
COL (SQE) Delay after TX_EN off	t1	0.65	–	1.6	us	–
COL (SQE) Pulse duration	t2	0.5	–	1.5	us	–

1. Typical values are at 25 °C and are for design aid only; not guaranteed and not subject to production testing.

Figure 30. Auto Negotiation and Fast Link Pulse Timing

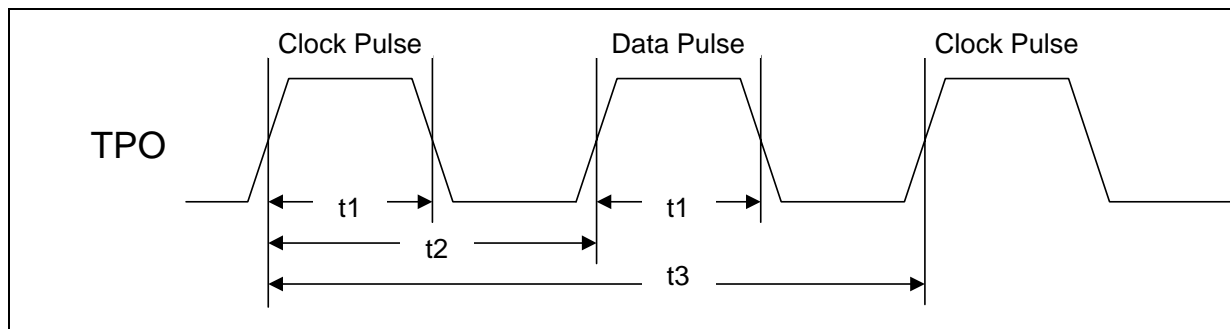

Figure 31. Fast Link Pulse Timing

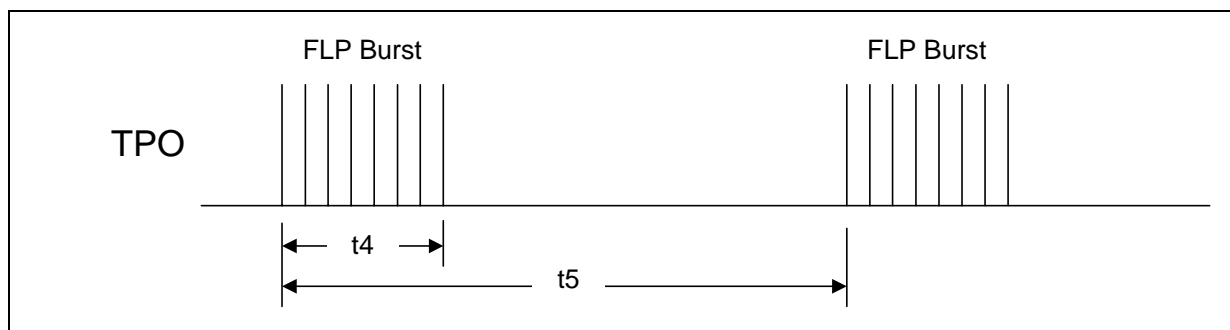

Table 31. Auto Negotiation and Fast Link Pulse Timing Parameters

Parameter	Sym	Min	Typ ¹	Max	Units	Test Conditions
Clock/Data pulse width	t1	–	100	–	ns	–
Clock pulse to Data pulse	t2	55.5	–	63.8	μs	–
Clock pulse to Clock pulse	t3	123	–	127	μs	–
FLP burst width	t4	–	2	–	ms	–
FLP burst to FLP burst	t5	8	12	24	ms	–
Clock/Data pulses per burst	–	17	–	33	ea	–

1. Typical values are at 25 °C and are for design aid only; not guaranteed and not subject to production testing.

Figure 32. MDIO Input Timing

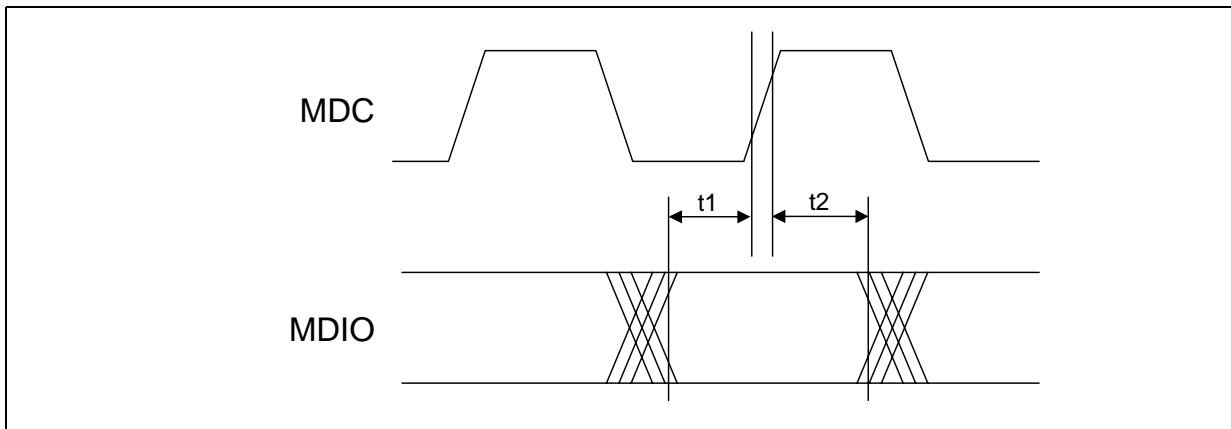

Figure 33. MDIO Output Timing

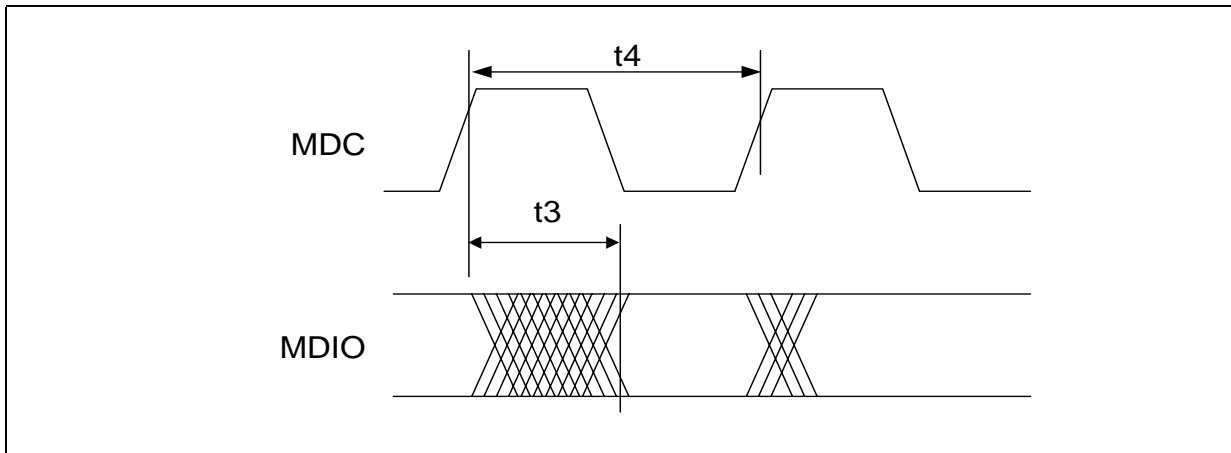

Table 32. MDIO Timing Parameters

Parameter	Sym	Min	Typ ¹	Max	Units	Test Conditions
MDIO setup before MDC, sourced by STA	t1	10	–	–	ns	–
MDIO hold after MDC, sourced by STA	t2	5	–	–	ns	–
MDC to MDIO output delay, source by PHY	t3	–	–	150	ns	–
MDC period	t4	125	–	–	ns	MDC = 8 MHz

1. Typical values are at 25° C and are for design aid only; not guaranteed and not subject to production testing.

Figure 34. Power-Up Timing

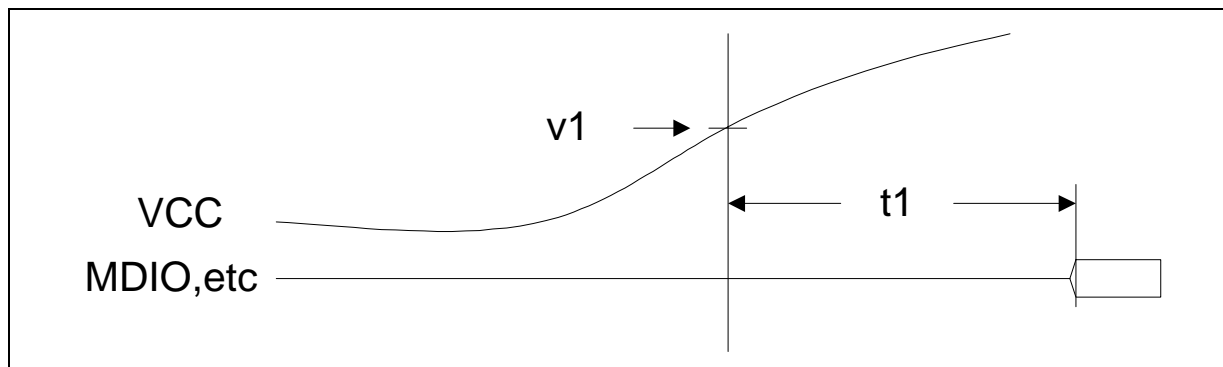

Table 33. Power-Up Timing Parameters

Parameter	Sym	Min	Typ ¹	Max	Units	Test Conditions
Voltage threshold	v1	–	2.9	–	V	–
Power Up delay ²	t1	–	–	300	μs	–

1. Typical values are at 25° C and are for design aid only; not guaranteed and not subject to production testing.
 2. Power Up Delay is specified as a maximum value because it refers to the PHY's guaranteed performance - the PHY comes out of reset after a delay of No MORE Than 300 μs. System designers should consider this as a minimum value - After threshold v1 is reached, the MAC should delay No LESS Than 300 μs before accessing the MDIO port.

Figure 35. RESET Pulse Width and Recovery Timing

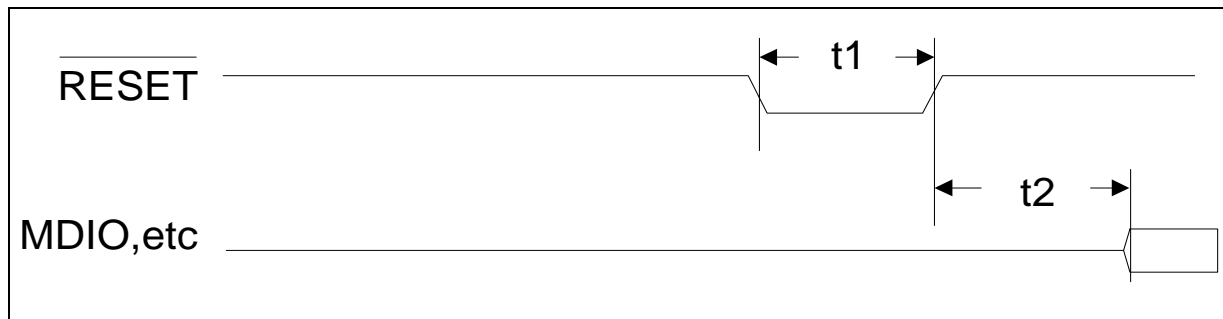

Table 34. RESET Pulse Width and Recovery Timing Parameters

Parameter	Sym	Min	Typ ¹	Max	Units	Test Conditions
RESET pulse width	t1	10	–	–	ns	–
RESET recovery delay ²	t2	–	–	300	μs	–

1. Typical values are at 25° C and are for design aid only; not guaranteed and not subject to production testing.
 2. Reset Recovery Delay is specified as a maximum value because it refers to the PHY's guaranteed performance - the PHY comes out of reset after a delay of No MORE Than 300 μs. System designers should consider this as a minimum value - After de-asserting RESET*, the MAC should delay No LESS Than 300 μs before accessing the MDIO port.

6.0 Register Definitions

The LXT972A register set includes multiple 16-bit registers. Refer to [Table 35](#) for a complete register listing.

- Base registers (0 through 8) are defined in accordance with the “Reconciliation Sublayer and Media Independent Interface” and “Physical Layer Link Signaling for 10/100Mbps Auto-Negotiation” sections of the IEEE 802.3 standard.
- Additional registers are defined in accordance with the IEEE 802.3 standard for adding unique chip functions.

Table 35. Register Set

Address	Register Name	Bit Assignments
0	Control Register	Refer to Table 37 on page 58
1	Status Register #1	Refer to Table 38 on page 58
2	PHY Identification Register 1	Refer to Table 39 on page 59
3	PHY Identification Register 2	Refer to Table 40 on page 60
4	Auto-Negotiation Advertisement Register	Refer to Table 41 on page 61
5	Auto-Negotiation Link Partner Base Page Ability Register	Refer to Table 42 on page 62
6	Auto-Negotiation Expansion Register	Refer to Table 43 on page 63
7	Auto-Negotiation Next Page Transmit Register	Refer to Table 44 on page 63
8	Auto-Negotiation Link Partner Received Next Page Register	Refer to Table 45 on page 64
9	1000BASE-T/100BASE-T2 Control Register	Not Implemented
10	1000BASE-T/100BASE-T2 Status Register	Not Implemented
15	Extended Status Register	Not Implemented
16	Port Configuration Register	Refer to Table 46 on page 64
17	Status Register #2	Refer to Table 47 on page 65
18	Interrupt Enable Register	Refer to Table 48 on page 66
19	Interrupt Status Register	Refer to Table 49 on page 66
20	LED Configuration Register	Refer to Table 50 on page 68
21- 29	Reserved	
30	Transmit Control Register	Refer to Table 51 on page 69

Table 36. Register Bit Map

Reg Title	Bit Fields																Addr
	B15	B14	B13	B12	B11	B10	B9	B8	B7	B6	B5	B4	B3	B2	B1	B0	
Control Register																	
Control	Reset	Loopback	Speed Select	A/N Enable	Power Down	Isolate	Re-start A/N	Duplex Mode	COL Test	Speed Select	Reserved					0	
Status Register																	
Status	100Base-T4	100Base-X Full Duplex	100Base-X Half Duplex	10Mbps Full Duplex	10Mbps Half Duplex	100Base-T2 Full Duplex	100Base-T2 Half Duplex	Extended Status	Reserved	MF Preamble Suppress	A/N Complete	Remote Fault	A/N Ability	Link Status	Jabber Detect	Extended Capability	1
PHY ID Registers																	
PHY ID 1	15	14	13	12	11	10	9	8	7	6	5	4	3	2	1	0	2
PHY ID 2	PHY ID No						MFR Model No						MFR Rev No				3
Auto-Negotiation Advertisement Register																	
A/N Advertise	Next Page	Reserved	Remote Fault	Reserved	Asymm Pause	Pause	100Base-T4	100Base-TX Full Duplex	100Base-TX	10Base-T Full Duplex	10Base-T	IEEE Selector Field				4	
Auto-Negotiation Link Partner Base Page Ability Register																	
A/N Link Ability	Next Page	Ack	Remote Fault	Reserved	Asymm Pause	Pause	100Base-T4	100Base-TX Full Duplex	100Base-TX	10Base-T Full Duplex	10Base-T	IEEE Selector Field				5	
Auto-Negotiation Expansion Register																	
A/N Expansion	Reserved										Base Page	Parallel Detect Fault	Link Partner Next Page Able	Next Page Able	Page Received	Link Partner A/N Able	6
Auto-Negotiation Next Page Transmit Register																	
A/N Next Page Txmit	Next Page	Reserved	Message Page	Ack 2	Toggle	Message / Unformatted Code Field										7	
Auto-Negotiation Link Partner Next Page Receive Register																	
A/N Link Next Page	Next Page	Ack	Message Page	Ack 2	Toggle	Message / Unformatted Code Field										8	
Configuration Register																	
Port Config	Reserved	Force Link Pass	Txmit Disable	Bypass Scrambler (100TX)	Reserved)	Jabber (10T)	SQE (10T)	TP Loopback (10T)	CRS Select (10T)	Reserved	PRE_EN	Reserved	Reserved	Alternate Next Page	Reserved	Reserved	16

Table 36. Register Bit Map (Continued)

Reg Title	Bit Fields																Addr	
	B15	B14	B13	B12	B11	B10	B9	B8	B7	B6	B5	B4	B3	B2	B1	B0		
Status Register #2																		
Status Register #2	Reserved	10/100 Mode	Transmit Status	Receive Status	Collision Status	Link	Duplex Mode	Auto-Neg	Auto-Neg Complete	Reserved	Polarity	Pause	Error	Reserved	Reserved		17	
Interrupt Enable Register																		
Interrupt Enable	Reserved							Reserved	Auto-Neg Mask	Speed Mask	Duplex Mask	Link Mask	Reserved	Reserved	Interrupt Enable	Test Interrupt		18
Interrupt Status Register																		
Interrupt Status	Reserved							Reserved	Auto-Neg Done	Speed Change	Duplex Change	Link Change	Reserved	MD Interrupt	Reserved	Reserved		19
LED Configuration Register																		
LED Config	LED1				LED2				LED3				LED Freq	Pulse Stretch	Reserved		20	
Transmit Control Register																		
Trans. Control	Reserved		Transmit Low Pwr	Port Rise Time Control		Reserved											30	

Table 37. Control Register (Address 0)

Bit	Name	Description	Type ¹	Default		
0.15	Reset	1 = PHY reset 0 = Normal operation	R/W SC	0		
0.14	Loopback	1 = Enable loopback mode 0 = Disable loopback mode	R/W	0		
0.13	Speed Selection	0.6	0.13	Speed Selected	R/W	Note 2
		1	1	Reserved		
		1	0	1000Mbps (not supported)		
		0	1	100Mbps		
		0	0	10Mbps		
0.12	Auto-Negotiation Enable	1 = Enable Auto-Negotiation Process 0 = Disable Auto-Negotiation Process	R/W	Note 2		
0.11	Power-Down	1 = Power-down 0 = Normal operation	R/W	0		
0.10	Isolate	1 = Electrically isolate PHY from MII 0 = Normal operation	R/W	0		
0.9	Restart Auto-Negotiation	1 = Restart Auto-Negotiation Process 0 = Normal operation	R/W SC	0		
0.8	Duplex Mode	1 = Full Duplex 0 = Half Duplex	R/W	Note 2		
0.7	Collision Test	1 = Enable COL signal test 0 = Disable COL signal test	R/W	0		
0.6	Speed Selection	0.6	0.13	Speed Selected	R/W	0
		1	1	Reserved		
		1	0	1000Mbps (not supported)		
		0	1	100Mbps		
		0	0	10Mbps		
0.5:0	Reserved	Write as 0, ignore on Read	R/W	00000		
1. R/W = Read/Write RO = Read Only SC = Self Clearing 2. Default value of bits 0.12, 0.13 and 0.8 are determined by the LED/CFG pins (refer to Table 8 on page 24).						

Table 38. MII Status Register #1 (Address 1)

Bit	Name	Description	Type ¹	Default
1.15	100BASE-T4 Not Supported	1 = PHY able to perform 100BASE-T4 0 = PHY not able to perform 100BASE-T4	RO	0
1.14	100BASE-X Full-Duplex	1 = PHY able to perform full-duplex 100BASE-X 0 = PHY not able to perform full-duplex 100BASE-X	RO	1
1.13	100BASE-X Half-Duplex	1 = PHY able to perform half-duplex 100BASE-X 0 = PHY not able to perform half-duplex 100BASE-X	RO	1
1. RO = Read Only LL = Latching Low LH = Latching High				

Table 38. MII Status Register #1 (Address 1)

Bit	Name	Description	Type ¹	Default
1.12	10Mbps Full-Duplex	1 = PHY able to operate at 10Mbps in full-duplex mode 0 = PHY not able to operate at 10Mbps full-duplex mode	RO	1
1.11	10Mbps Half-Duplex	1 = PHY able to operate at 10Mbps in half-duplex mode 0 = PHY not able to operate at 10Mbps in half-duplex	RO	1
1.10	100BASE-T2 Full-Duplex Not Supported	1 = PHY able to perform full-duplex 100BASE-T2 0 = PHY not able to perform full-duplex 100BASE-T2	RO	0
1.9	100BASE-T2 Half-Duplex Not Supported	1 = PHY able to perform half duplex 100BASE-T2 0 = PHY not able to perform half-duplex 100BASE-T2	RO	0
1.8	Extended Status	1 = Extended status information in register 15 0 = No extended status information in register 15	RO	0
1.7	Reserved	1 = ignore when read	RO	0
1.6	MF Preamble Suppression	1 = PHY accepts management frames with preamble suppressed 0 = PHY will not accept management frames with preamble suppressed	RO	0
1.5	Auto-Negotiation Complete	1 = Auto-negotiation complete 0 = Auto-negotiation not complete	RO	0
1.4	Remote Fault	1 = Remote fault condition detected 0 = No remote fault condition detected	RO/LH	0
1.3	Auto-Negotiation Ability	1 = PHY is able to perform Auto-Negotiation 0 = PHY is not able to perform Auto-Negotiation	RO	1
1.2	Link Status	1 = Link is up 0 = Link is down	RO/LL	0
1.1	Jabber Detect	1 = Jabber condition detected 0 = Jabber condition not detected	RO/LH	0
1.0	Extended Capability	1 = Extended register capabilities 0 = Basic register capabilities	RO	1
1. RO = Read Only LL = Latching Low LH = Latching High				

Table 39. PHY Identification Register 1 (Address 2)

Bit	Name	Description	Type ¹	Default
2.15:0	PHY ID Number	The PHY identifier composed of bits 3 through 18 of the OUI.	RO	0013 hex
1. RO = Read Only				

Table 40. PHY Identification Register 2 (Address 3)

Bit	Name	Description	Type ¹	Default
3.15:10	PHY ID number	The PHY identifier composed of bits 19 through 24 of the OUI.	RO	011110
3.9:4	Manufacturer's model number	6 bits containing manufacturer's part number.	RO	001110
3.3:0	Manufacturer's revision number	4 bits containing manufacturer's revision number.	RO	xxxx (See LXT971A/972A Specification Update)

1. RO = Read Only

Figure 36. PHY Identifier Bit Mapping

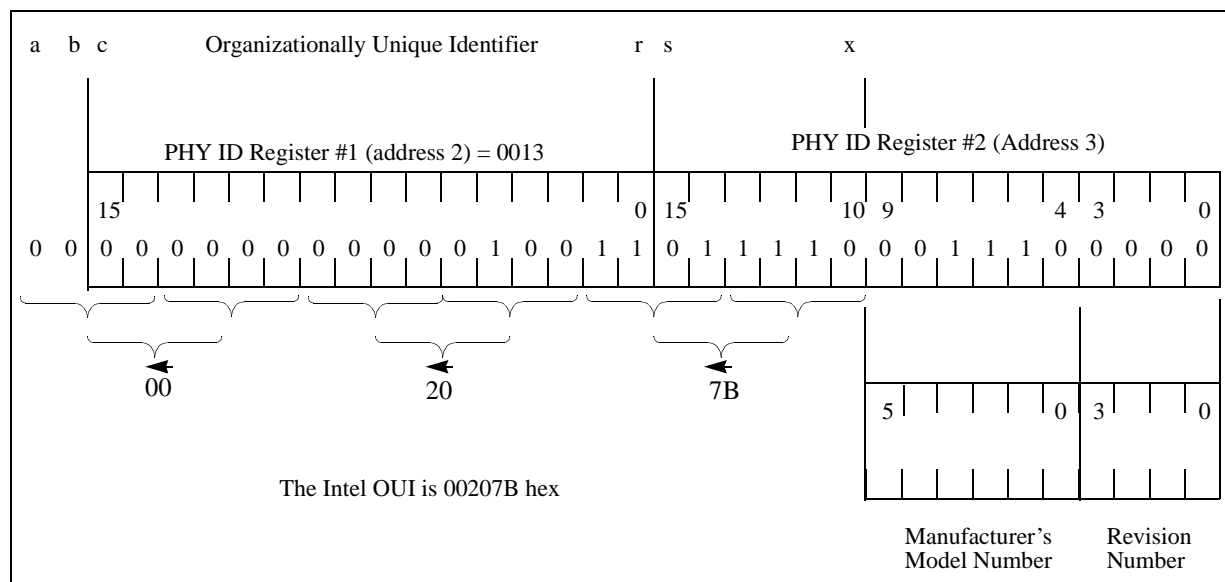

Table 41. Auto Negotiation Advertisement Register (Address 4)

Bit	Name	Description	Type ¹	Default
4.15	Next Page	1 = Port has ability to send multiple pages. 0 = Port has no ability to send multiple pages.	R/W	0
4.14	Reserved	Ignore.	RO	0
4.13	Remote Fault	1 = Remote fault. 0 = No remote fault.	R/W	0
4.12	Reserved	Ignore.	R/W	0
4.11	Asymmetric Pause	Pause operation defined in Clause 40 and 27.	R/W	0
4.10	Pause	1 = Pause operation enabled for full-duplex links. 0 = Pause operation disabled.	R/W	Note 2
4.9	100BASE-T4	1 = 100BASE-T4 capability is available. 0 = 100BASE-T4 capability is not available. (The LXT972A does not support 100BASE-T4 but allows this bit to be set to advertise in the Auto-Negotiation sequence for 100BASE-T4 operation. An external 100BASE-T4 transceiver could be switched in if this capability is desired.)	R/W	0
4.8	100BASE-TX full-duplex	1 = Port is 100BASE-TX full-duplex capable. 0 = Port is not 100BASE-TX full-duplex capable.	R/W	Note 3
4.7	100BASE-TX	1 = Port is 100BASE-TX capable. 0 = Port is not 100BASE-TX capable.	R/W	Note 3
4.6	10BASE-T full-duplex	1 = Port is 10BASE-T full-duplex capable. 0 = Port is not 10BASE-T full-duplex capable.	R/W	Note 3
4.5	10BASE-T	1 = Port is 10BASE-T capable. 0 = Port is not 10BASE-T capable.	R/W	Note 3
4.4:0	Selector Field, S<4:0>	<00001> = IEEE 802.3. <00010> = IEEE 802.9 ISLAN-16T. <00000> = Reserved for future Auto-Negotiation development. <11111> = Reserved for future Auto-Negotiation development. Unspecified or reserved combinations should not be transmitted.	R/W	00001
1. R/W = Read/Write RO = Read Only 2. Default value of bit 4.10 is determined by pin 33/H8. 3. Default values of bits 4.5, 4.6, 4.7, and 4.8 are determined by LED/CFGn pins at reset. Refer to Table 8 for details.				

Table 42. Auto Negotiation Link Partner Base Page Ability Register (Address 5)

Bit	Name	Description	Type ¹	Default
5.15	Next Page	1 = Link Partner has ability to send multiple pages. 0 = Link Partner has no ability to send multiple pages.	RO	N/A
5.14	Acknowledge	1 = Link Partner has received Link Code Word from LXT972A. 0 = Link Partner has not received Link Code Word from the LXT972A.	RO	N/A
5.13	Remote Fault	1 = Remote fault. 0 = No remote fault.	RO	N/A
5.12	Reserved	Ignore.	RO	N/A
5.11	Asymmetric Pause	Pause operation defined in Clause 40 and 27. 1 = Link Partner is Pause capable. 0 = Link Partner is not Pause capable.	RO	N/A
5.10	Pause	1 = Link Partner is Pause capable. 0 = Link Partner is not Pause capable.	RO	N/A
5.9	100BASE-T4	1 = Link Partner is 100BASE-T4 capable. 0 = Link Partner is not 100BASE-T4 capable.	RO	N/A
5.8	100BASE-TX full-duplex	1 = Link Partner is 100BASE-TX full-duplex capable. 0 = Link Partner is not 100BASE-TX full-duplex capable.	RO	N/A
5.7	100BASE-TX	1 = Link Partner is 100BASE-TX capable. 0 = Link Partner is not 100BASE-TX capable.	RO	N/A
5.6	10BASE-T full-duplex	1 = Link Partner is 10BASE-T full-duplex capable. 0 = Link Partner is not 10BASE-T full-duplex capable.	RO	N/A
5.5	10BASE-T	1 = Link Partner is 10BASE-T capable. 0 = Link Partner is not 10BASE-T capable.	RO	N/A
5.4:0	Selector Field S<4:0>	<00001> = IEEE 802.3. <00010> = IEEE 802.9 ISLAN-16T. <00000> = Reserved for future Auto-Negotiation development. <11111> = Reserved for future Auto-Negotiation development. Unspecified or reserved combinations shall not be transmitted.	RO	N/A

1. RO = Read Only

Table 43. Auto Negotiation Expansion (Address 6)

Bit	Name	Description	Type ¹	Default
6.15:6	Reserved	Ignore on read.	RO	0
6.5	Base Page	This bit indicates the status of the Auto-Negotiation variable, base page. It flags synchronization with the Auto-Negotiation state diagram allowing detection of interrupted links. This bit is only used if bit 16.1 (Alternate NP feature) is set. 1 = basepage = true 0 = basepage = false	RO/ LH	0
6.4	Parallel Detection Fault	1 = Parallel detection fault has occurred. 0 = Parallel detection fault has not occurred.	RO/ LH	0
6.3	Link Partner Next Page Able	1 = Link partner is next page able. 0 = Link partner is not next page able.	RO	0
6.2	Next Page Able	1 = Local device is next page able. 0 = Local device is not next page able.	RO	1
6.1	Page Received	1 = Indicates that a new page has been received and the received code word has been loaded into register 5 (base pages) or register 8 (next pages) as specified in clause 28 of 802.3. This bit is cleared on read. If bit 16.1 is set, the Page Received bit is also cleared when mr_page_rx = false or transmit_disable = true.	RO LH	0
6.0	Link Partner A/N Able	1 = Link partner is auto-negotiation able. 0 = Link partner is not auto-negotiation able.	RO	0

1. RO = Read Only LH = Latching High

Table 44. Auto Negotiation Next Page Transmit Register (Address 7)

Bit	Name	Description	Type ¹	Default
7.15	Next Page (NP)	1 = Additional next pages follow 0 = Last page	R/W	0
7.14	Reserved	Write as 0, ignore on read	RO	0
7.13	Message Page (MP)	1 = Message page 0 = Unformatted page	R/W	1
7.12	Acknowledge 2 (ACK2)	1 = Complies with message 0 = Can not comply with message	R/W	0
7.11	Toggle (T)	1 = Previous value of the transmitted Link Code Word equalled logic zero 0 = Previous value of the transmitted Link Code Word equalled logic one	R/W	0
7.10:0	Message/Unformatted Code Field		R/W	00000000 001

1. RO = Read Only. R/W = Read/Write

Table 45. Auto Negotiation Link Partner Next Page Receive Register (Address 8)

Bit	Name	Description	Type ¹	Default
8.15	Next Page (NP)	1 = Link Partner has additional next pages to send 0 = Link Partner has no additional next pages to send	RO	0
8.14	Acknowledge (ACK)	1 = Link Partner has received Link Code Word from LXT972A 0 = Link Partner has not received Link Code Word from LXT972A	RO	0
8.13	Message Page (MP)	1 = Page sent by the Link Partner is a Message Page 0 = Page sent by the Link Partner is an Unformatted Page	RO	0
8.12	Acknowledge 2 (ACK2)	1 = Link Partner complies with the message 0 = Link Partner can not comply with the message	RO	0
8.11	Toggle (T)	1 = Previous value of the transmitted Link Code Word equalled logic zero 0 = Previous value of the transmitted Link Code Word equalled logic one	RO	0
8.10:0	Message/Unformatted Code Field	User definable	RO	0

1. RO = Read Only.

Table 46. Configuration Register (Address 16, Hex 10)

Bit	Name	Description	Type ¹	Default
16.15	Reserved	Write as zero, ignore on read.	R/W	0
16.14	Force Link Pass	1 = Force Link pass 0 = Normal operation	R/W	0
16.13	Transmit Disable	1 = Disable Twisted Pair transmitter 0 = Normal Operation	R/W	0
16.12	Bypass Scrambler (10BASE-TX)	1 = Bypass Scrambler and Descrambler 0 = Normal Operation	R/W	0
16.11	Reserved	Ignore	R/W	0
16.10	Jabber (10BASE-T)	1 = Disable Jabber Correction 0 = Normal operation	R/W	0
16.9	SQE (10BASE-T)	1 = Enable Heart Beat 0 = Disable Heart Beat	R/W	0
16.8	TP Loopback (10BASE-T)	1 = Disable TP loopback during half-duplex operation 0 = Normal Operation	R/W	0
16.7	CRS Select (10BASE-T)	1 = CRS deassert extends to RX_DV deassert 0 = Normal Operation	R/W	1
16.6	Reserved	Write as zero, ignore on read.	R/W	0
16.5	PRE_EN	Preamble Enable. 0 = Set RX_DV high coincident with SFD. 1 = Set RX_DV high and RXD = preamble when CRS is asserted.	R/W	0
16.4:3	Reserved	Write as zero, ignore on read.	R/W	00

1. R/W = Read /Write, LHR = Latches High on Reset

Table 46. Configuration Register (Address 16, Hex 10) (Continued)

Bit	Name	Description	Type ¹	Default
16.2	Reserved	Write as zero, ignore on read.	R/W	0
16.1	Alternate NP feature	1 = Enable alternate auto negotiate next page feature. 0 = Disable alternate auto negotiate next page feature	R/W	0
16.0	Reserved	Write as zero, ignore on read.	R/W	0

1. R/W = Read /Write, LHR = Latches High on Reset

Table 47. Status Register #2 (Address 17)

Bit	Name	Description	Type ¹	Default
17.15	Reserved	Always 0.	RO	0
17.14	10/100 Mode	1 = LXT972A is operating in 100BASE-TX mode. 0 = LXT972A is not operating 100BASE-TX mode.	RO	0
17.13	Transmit Status	1 = LXT972A is transmitting a packet. 0 = LXT972A is not transmitting a packet.	RO	0
17.12	Receive Status	1 = LXT972A is receiving a packet. 0 = LXT972A is not receiving a packet.	RO	0
17.11	Collision Status	1 = Collision is occurring. 0 = No collision.	RO	0
17.10	Link	1 = Link is up. 0 = Link is down.	RO	0
17.9	Duplex Mode	1 = Full-duplex. 0 = Half-duplex.	RO	0
17.8	Auto-Negotiation	1 = LXT972A is in Auto-Negotiation Mode. 0 = LXT972A is in manual mode.	RO	0
17.7	Auto-Negotiation Complete	1 = Auto-negotiation process completed. 0 = Auto-negotiation process not completed. This bit is only valid when auto negotiate is enabled, and is equivalent to bit 1.5.	RO	0
17.6	Reserved	Reserved.	RO	0
17.5	Polarity	1 = Polarity is reversed. 0 = Polarity is not reversed.	RO	0
17.4	Pause	1 = Device Pause capable. 0 = Device Not Pause capable.	RO	0
17:3	Error	1 = Error Occurred (Remote Fault, X,Y,Z). 0 = No error occurred.	RO	0
17:2	Reserved	Always 0.	RO	0
17:1	Reserved	Always 0.	RO	0
17.0	Reserved	Always 0.	RO	0

1. RO = Read Only. R/W = Read/Write

Table 48. Interrupt Enable Register (Address 18)

Bit	Name	Description	Type ¹	Default
18.15:9	Reserved	Write as 0; ignore on read.	R/W	N/A
18.8	Reserved	Write as 0; ignore on read.	R/W	0
18.7	ANMSK	Mask for Auto Negotiate Complete 1 = Enable event to cause interrupt. 0 = Do not allow event to cause interrupt.	R/W	0
18.6	SPEEDMSK	Mask for Speed Interrupt 1 = Enable event to cause interrupt. 0 = Do not allow event to cause interrupt.	R/W	0
18.5	DUPLEXMSK	Mask for Duplex Interrupt 1 = Enable event to cause interrupt. 0 = Do not allow event to cause interrupt.	R/W	0
18.4	LINKMSK	Mask for Link Status Interrupt 1 = Enable event to cause interrupt. 0 = Do not allow event to cause interrupt.	R/W	0
18.3	Reserved	Write as 0, ignore on read.	R/W	0
18.2	Reserved	Write as 0, ignore on read.	R/W	0
18.1	INTEN	1 = Enable interrupts. 0 = Disable interrupts.	R/W	0
18.0	TINT	1 = Force interrupt on $\overline{\text{MDINT}}$. 0 = Normal operation.	R/W	0

1. R/W = Read /Write

Table 49. Interrupt Status Register (Address 19, Hex 13)

Bit	Name	Description	Type ¹	Default
19.15:9	Reserved	Ignore	RO	N/A
19.8	Reserved	Ignore	RO	0
19.7	ANDONE	Auto Negotiation Status 1 = Auto Negotiation has completed. 0 = Auto Negotiation has not completed.	RO/SC	N/A
19.6	SPEEDCHG	Speed Change Status 1 = A Speed Change has occurred since last reading this register. 0 = A Speed Change has not occurred since last reading this register.	RO/SC	0
19.5	DUPLEXCHG	Duplex Change Status 1 = A Duplex Change has occurred since last reading this register. 0 = A Duplex Change has not occurred since last reading this register.	RO/SC	0
19.4	LINKCHG	Link Status Change Status 1 = A Link Change has occurred since last reading this register. 0 = A Link Change has not occurred since last reading this register.	RO/SC	0
19.3	Reserved	Ignore	RO	0

1. R/W = Read/Write, SC = Self Clearing.

Table 49. Interrupt Status Register (Address 19, Hex 13) (Continued)

Bit	Name	Description	Type ¹	Default
19.2	MDINT	1 = MII interrupt pending. 0 = No MII interrupt pending.	RO	
19.1	Reserved	Ignore.	RO	N/A
19.0	Reserved	Ignore	RO	0

1. R/W = Read/Write, SC = Self Clearing.

Table 50. LED Configuration Register (Address 20, Hex 14)

Bit	Name	Description	Type ¹	Default
20.15:12	LED1 Programming bits	0000 = Display Speed Status (Continuous, Default) 0001 = Display Transmit Status (Stretched) 0010 = Display Receive Status (Stretched) 0011 = Display Collision Status (Stretched) 0100 = Display Link Status (Continuous) 0101 = Display Duplex Status (Continuous) 0110 = Unused 0111 = Display Receive or Transmit Activity (Stretched) 1000 = Test mode- turn LED on (Continuous) 1001 = Test mode- turn LED off (Continuous) 1010 = Test mode- blink LED fast (Continuous) 1011 = Test mode- blink LED slow (Continuous) 1100 = Display Link and Receive Status combined ² (Stretched) ³ 1101 = Display Link and Activity Status combined ² (Stretched) ³ 1110 = Display Duplex and Collision Status combined ⁴ (Stretched) ³ 1111 = Unused	R/W	0000
20.11:8	LED2 Programming bits	0000 = Display Speed Status 0001 = Display Transmit Status 0010 = Display Receive Status 0011 = Display Collision Status 0100 = Display Link Status (Default) 0101 = Display Duplex Status 0110 = Unused 0111 = Display Receive or Transmit Activity 1000 = Test mode- turn LED on 1001 = Test mode- turn LED off 1010 = Test mode- blink LED fast 1011 = Test mode- blink LED slow 1100 = Display Link and Receive Status combined ² (Stretched) ³ 1101 = Display Link and Activity Status combined ² (Stretched) ³ 1110 = Display Duplex and Collision Status combined ⁴ (Stretched) ³ 1111 = Unused	R/W	0100
20.7:4	LED3 Programming bits	0000 = Display Speed Status 0001 = Display Transmit Status 0010 = Display Receive Status (Default) 0011 = Display Collision Status 0100 = Display Link Status 0101 = Display Duplex Status 0110 = Unused 0111 = Display Receive or Transmit Activity 1000 = Test mode- turn LED on 1001 = Test mode- turn LED off 1010 = Test mode- blink LED fast 1011 = Test mode- blink LED slow 1100 = Display Link and Receive Status combined ² (Stretched) ³ 1101 = Display Link and Activity Status combined ² (Stretched) ³ 1110 = Display Duplex and Collision Status combined ⁴ (Stretched) ³ 1111 = Unused	R/W	0010
<p>1. R/W = Read /Write RO = Read Only LH = Latching High</p> <p>2. Link status is the primary LED driver. The LED is asserted (solid ON) when the link is up. The secondary LED driver (Receive or Activity) causes the LED to change state (blink).</p> <p>3. Combined event LED settings are not affected by Pulse Stretch bit 20.1. These display settings are stretched regardless of the value of 20.1.</p> <p>4. Duplex status is the primary LED driver. The LED is asserted (solid ON) when the link is full duplex. Collision status is the secondary LED driver. The LED changes state (blinks) when a collision occurs.</p> <p>5. Values are relative approximations. Not guaranteed or production tested.</p>				

Table 50. LED Configuration Register (Address 20, Hex 14) (Continued)

Bit	Name	Description	Type ¹	Default
20.3:2	LEDFREQ ⁵	00 = Stretch LED events to 30 ms. 01 = Stretch LED events to 60 ms. 10 = Stretch LED events to 100 ms. 11 = Reserved.	R/W	00
20.1	PULSE-STRETCH	0 = Disable pulse stretching of all LEDs. 1 = Enable pulse stretching of all LEDs.	R/W	1
20.0	Reserved	Ignore.	R/W	N/A

1. R/W = Read /Write
RO = Read Only
LH = Latching High

2. Link status is the primary LED driver. The LED is asserted (solid ON) when the link is up. The secondary LED driver (Receive or Activity) causes the LED to change state (blink).

3. Combined event LED settings are not affected by Pulse Stretch bit 20.1. These display settings are stretched regardless of the value of 20.1.

4. Duplex status is the primary LED driver. The LED is asserted (solid ON) when the link is full duplex. Collision status is the secondary LED driver. The LED changes state (blinks) when a collision occurs.

5. Values are relative approximations. Not guaranteed or production tested.

Table 51. Transmit Control Register #2 (Address 30)

Bit	Name	Description	Type ²	Default
30.15:11	Reserved	Ignore	R/W	0
30.12	Transmit Low Power	1 = Forces the transmitter into low power mode. Also forces a zero-differential transmission. 0 = Normal transmission.	R/W	0
30.11:10	Port Rise Time Control ¹	00 = 2.7 ns (default is pins TXSLEW<1:0>) 01 = 3.5 ns 10 = 2.3 ns 11 = 2.0 ns	R/W	N/A
30.9:0	Reserved	Ignore	R/W	0

1. Values are relative approximations. Not guaranteed or production tested.

2. R/W = Read/Write

7.0 Package Specification

Figure 37. LXT972A LQFP Package Specifications

