

RF Signal Processing Servo Amplifier for CD players

Description

The CXA1782BQ/BR is a bipolar IC with built-in RF signal processing and various servo ICs. A CD player servo can be configured by using this IC, DSP and driver.

Features

- Low operating voltage ($V_{cc} = 3.0$ to $5.5V$)
- Low power consumption ($39mW$, $V_{cc} = 3.0V$)
- Supports pickup of either current output, voltage output
- Automatic adjustment comparator for tracking balance and gain
- Single power supply operation

Applications

- RF I-V amplifier, RF amplifier
- Focus and tracking error amplifier
- APC circuit
- Mirror detection circuit
- Defect detection and prevention circuits
- Focus servo control
- Tracking servo control
- Sled servo control
- Comparators of tracking adjustment for balance and gain

Structure

Bipolar silicon monolithic IC

CXA1782BQ
48 pin QFP (Plastic)

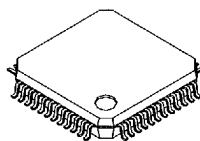

CXA1782BR
48 pin LQFP (Plastic)

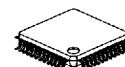
**Absolute Maximum Ratings** ($T_a = 25^\circ C$)

- Supply voltage V_{cc} 7 V
- Operating temperature T_{opr} -20 to $+75$ $^\circ C$
- Storage temperature T_{stg} -65 to $+150$ $^\circ C$
- Allowable power dissipation

P_D	833 (CXA1782BQ)	mW
	457 (CXA1782BR)	mW

Recommended Operating Condition

Operating supply voltage

V_{cc}	3.0 to 5.5	V
----------	------------	---

Sony reserves the right to change products and specifications without prior notice. This information does not convey any license by any implication or otherwise under any patents or other right. Application circuits shown, if any, are typical examples illustrating the operation of the devices. Sony cannot assume responsibility for any problems arising out of the use of these circuits.

Block Diagram

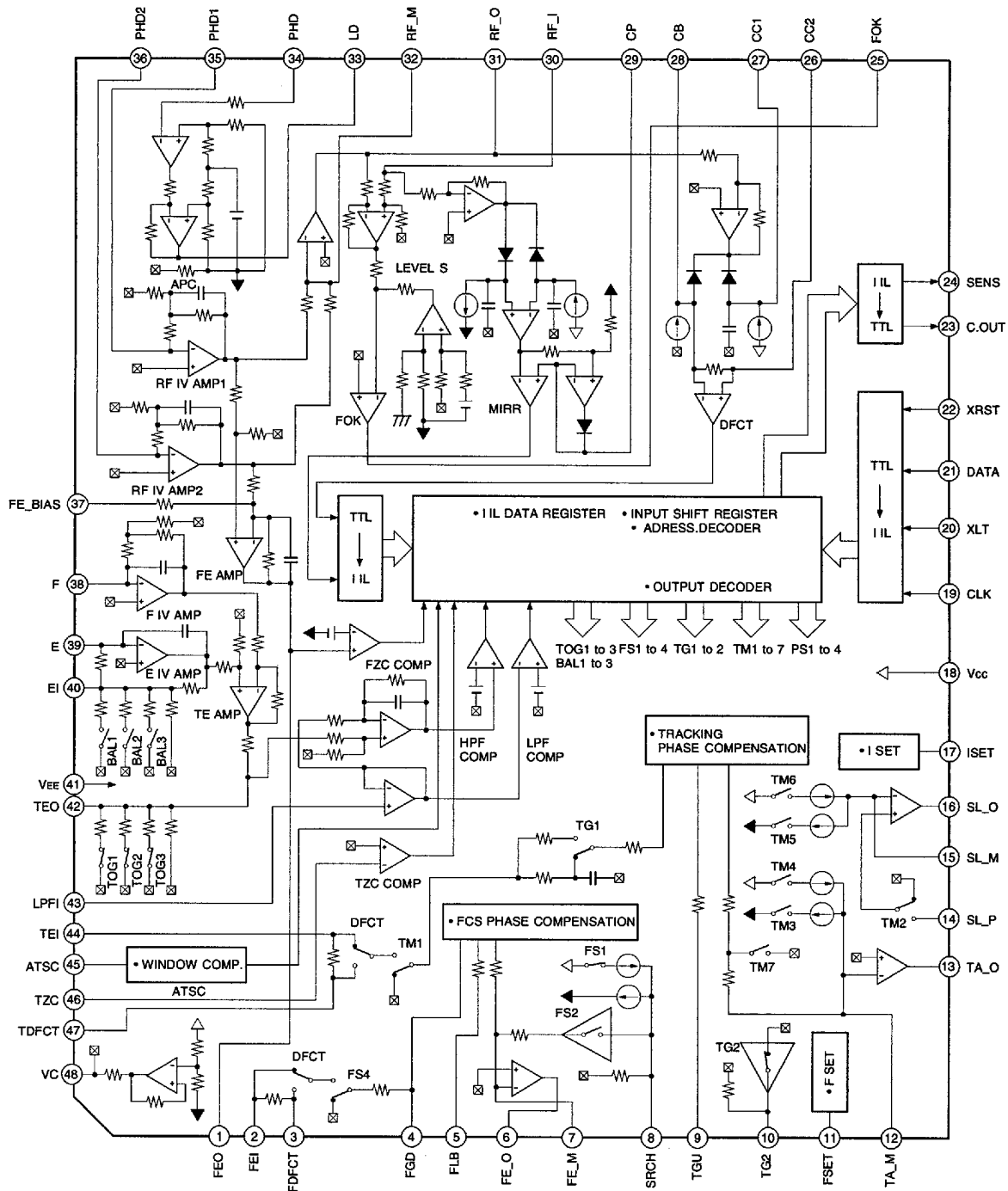

- The switch state in Block Diagram is for initial resetting.
- Switch turns to ○ side for 1 and to ● side for 0 in Serial Data Truth Table on pages 28 and 29.
- DFCT switch turns to ○ side when defect signal generates for DEFECT = E in Serial Data Truth Table.
- TG1 switch turns to ○ side and TG2 switch is left open when TG1 and TG2 (address 1 : D3) is 1.

Pin Description

Pin No.	Symbol	I/O	Equivalent circuit	Description
1	FEO	O		Focus error amplifier output. Connected internally to the FZC comparator input.
2	FEI	I		Focus error input.
3	FDFCT	I		Capacitor connection pin for defect time constant.
4	FGD	I		Ground this pin through a capacitor when decreasing the focus servo high-frequency gain.
5	FLB	I		External time constant setting pin for increasing the focus servo low frequency.
6	FE_O	O		Focus drive output.
13	TA_O	O		Tracking drive output.
16	SL_O	O		Sled drive output.
7	FE_M	I		Focus amplifier negative input pin.

Pin No.	Symbol	I/O	Equivalent circuit	Description
8	SRCH	I		External time constant setting pin for generating focus servo waveform.
9	TGU	I		External time constant setting pin for switching tracking high-frequency gain.
10	TG2	I		External time constant setting pin for switching tracking high-frequency gain.
11	FSET	I		High cut-off frequency setting pin for focus and tracking phase compensation amplifier.
12	TA_M	I		Tracking amplifier negative input.
14	SL_P	I		Sled amplifier non-inversed input.
15	SL_M	I		Sled amplifier negative input pin.

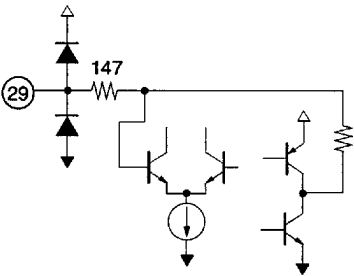
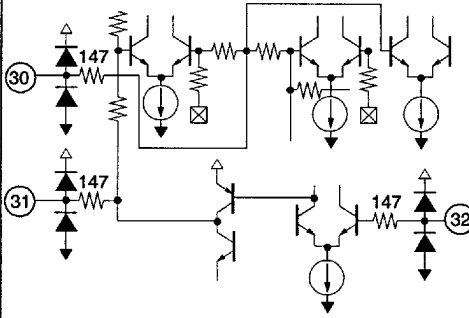
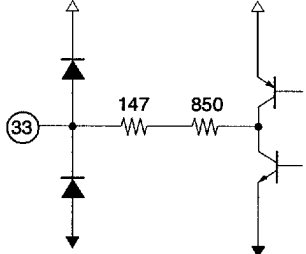
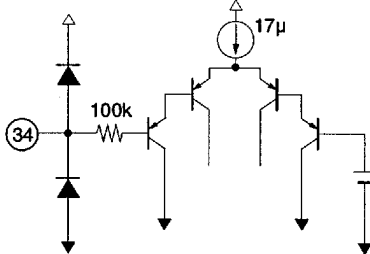
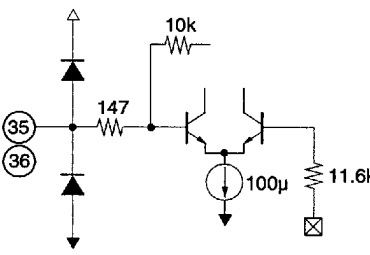
Pin No.	Symbol	I/O	Equivalent circuit	Description
29	CP	I		Connection pin for MIRR hold capacitor. MIRR comparator non-inversed input.
30	RF_I	I		Input pin for the RF summing amplifier output capacitance-coupled.
31	RF_O	O		RF summing amplifier output. Eye-pattern check point.
32	RF_M	I		RF summing amplifier inversed input. The RF amplifier gain is determined by the resistance connected between this pin and RFO pin.
33	LD	O		APC amplifier output.
34	PHD	I		APC amplifier input.
35 36	PHD1 PHD2	I I		RF I-V amplifier inversed input. Connect these pins to the photo diode A + C and B + D pins.

Pin No.	Symbol	I/O	Equivalent circuit	Description
37	FE_BIAS	I		Bias adjustment of focus error amplifier.
38 39	F E	I I		F I-V and E I-V amplifier inversed input. Connect these pins to photo diodes F and E.
40	EI	—		I-V amplifier E gain adjustment. (When not using automatic balance adjustment)
42	TEO	O		Tracking error amplifier output. E-F signal is output is input.
43	LPFI	I		Comparator input for balance adjustment. (Input from TEO through LPF.)

Pin No.	Symbol	I/O	Equivalent circuit	Description
44	TEI	I		Tracking error input.
47	TDFCT	I		Capacitor connection pin for defect time constant.
45	ATSC	I		Window comparator input for ATSC detection.
46	TZC	I		Tracking zero-cross comparator input.
48	VC	O		$(V_{CC} + V_{EE})/2$ DC voltage output.

(VCC = 1.5V, VEE = -1.5V, Ta = 25°C)

Electrical Characteristics

Item	SW conditions																Measurement conditions	Ratings		Unit					
	1	2	3	4	5	6	7	8	9	10	11	12	13	14	15	16		17	18		Min.	Typ.	Max.		
T1																			18	RST		10	14	20	mA
T2																			41			-20	-14	-10	mA
T3																			31			-50	0	50	mV
T4																						25.1	28.1	31.1	dB
T5																						1.2	1.3	—	V
T6																						—	-0.9	-0.3	V
T7																			1			-120	0	120	mV
T8																						27.0	30.0	33.0	dB
T9																						27.0	30.0	33.0	dB
T10																						-3.0	0	3.0	dB
T11																						1.0	1.3	—	V
T12																						—	-1.3	-1.0	V
T13																			42			-25	0	25	mV
T14																			3F			0.5	3.5	6.5	dB
T15																			3E			-2.33	-1.83	-1.33	dB
T16																			3D			-3.93	-3.43	-2.93	dB
T17																			3B			-6.69	-6.19	-5.69	dB
T18																			37			-0.6	2.4	5.4	dB
T19																			36			0.1	0.4	0.7	dB
T20																			35			0.4	0.7	1.0	dB

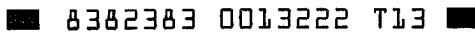

8382383 001012222 113

Item	SW conditions																Measurement conditions	Ratings		Unit			
	1	2	3	4	5	6	7	8	9	10	11	12	13	14	15	16		17	18		Min.	Typ.	Max.
T21				○														33	42	1.08	1.38	1.68	dB
T22			○															3F		0.5	0.6	—	V
T23				○																—	-0.6	-0.5	V
T24																○		33	V2 = 120mV	-900		-300	mV
T25															○				V2 = 145mV	-400		900	mV
T26															○				V2 = 170mV	350		1500	mV
T27															○				0.8mA sink			500	mV
T28								○										48		-100		100	mV
T29									○									08		18	21.0	24	dB
T30																			T29 + T8 (or T9)	49	51	53	dB
T31										○								00	Output gain difference between SD = 00 and SD = 08.			-35	dB
T32									○	○								08	V1 = 200mVdc	1.0	1.3	—	V
T33									○	○								08	V1 = -200mVdc	—	-1.3	-1.0	V
T34																		02		-640	-500	-360	mV
T35																		03		360	500	640	mV
T36																		00	Pin 1 threshold (preliminary)	185	225	265	mV
T37						○												25		12.25	14.6	17.6	dB
T38																			T37 + T14	16.1	18.1	20.1	dB
T39																○			Output gain difference between SD = 00 and SD = 08.			-39	dB
T40																○			V1 = -0.5Vdc	1.0	1.3		V



Item	SW conditions																		Measurement conditions	Ratings		Unit			
	1	2	3	4	5	6	7	8	9	10	11	12	13	14	15	16	17	18		Min.	Typ.		Max.		
T41						O						O							25	13	-1.3	-1.0	V		
T42																			2C		-500	-360	mV		
T43																			28		500	640	mV		
T44						O													25	10	-15	-7	mV		
T45						O													25		7	15	25	mV	
T46							O												25	24	-20	0	20	mV	
T47					O														30		12	17	22	mV	
T48																	O		38		120	130	140	mV	
T49														O						25	-400	-356	-330	mV	
T50														O					25	16	50			dB	
T51																			20					dB	
T52																			25		1.0	1.3		V	
T53																						-1.3	-1.0	V	
T54																			23		-750	-600	-450	mV	
T55																			22		450	600	750	mV	
T56							O								O				14	23				kHz	
T57								O																Vp-p	
T58									O												1.8			Vp-p	
T59																			10	24				1	kHz
T60																									kHz
T61																									Vp-p
T62																									Vp-p

Electrical Characteristics Measurement Circuit

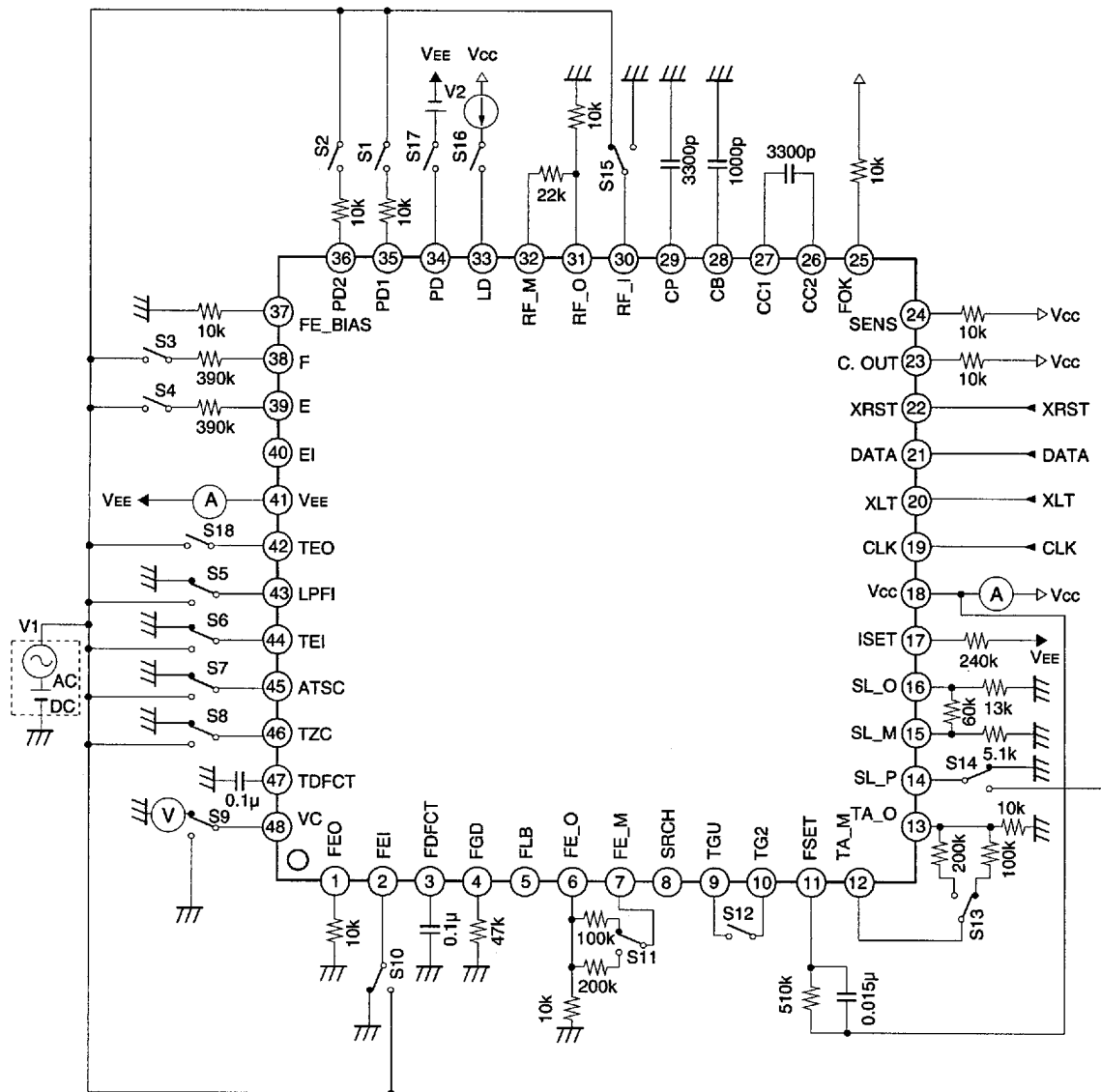

Description of Functions

RF Amplifier

The photo diode currents input to the input pins (PD1 and PD2) are each I-V converted across a 58k equivalent resistor at the PD IV amplifiers. The current is added at the RF summing amplifier, and the photo diode (A + B + C + D) current-voltage converted voltage is output to the RFO pin. An eye-pattern check can be performed at this pin.

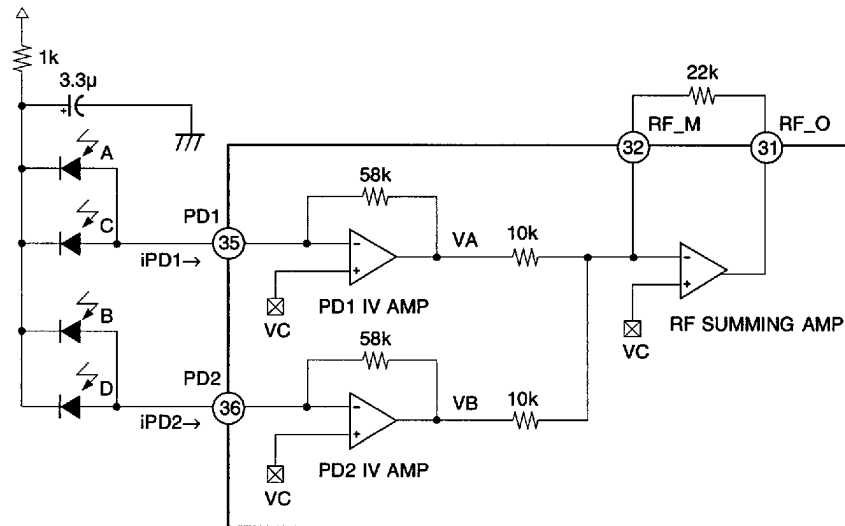

The low frequency component of the RFO output voltage is $V_{RFO} = 2.2 \times (V_A + V_B) = 127.6k\Omega \times (iPD1 + iPD2)$.

Focus Error Amplifier

The focus error amplifier calculates the difference between output VA and VB of the RF I-V amplifier, and output current-voltage converted voltage of the photo diode (A + C - B - D).

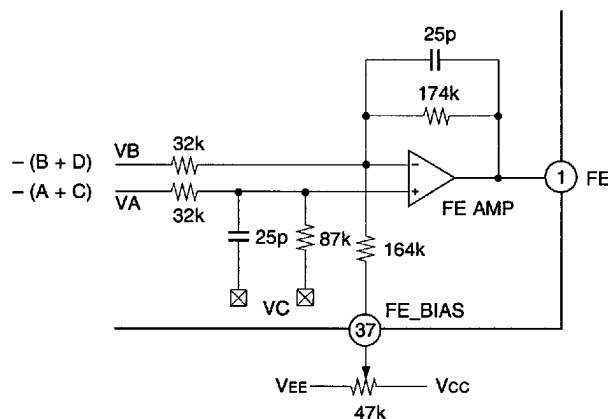

The FE output voltage (low frequency) is $V_{FE} = 5.4 \times (V_A - V_B) = (iPD2 - iPD1) \times 315k\Omega$.

Be aware that the rotation of the focus bias volume has reversed for the usual CD RF IC.

Tracking Error Amplifier

The photo diode currents input at E and F pins are each current-voltage converted by the E I-V and F I-V amplifiers.

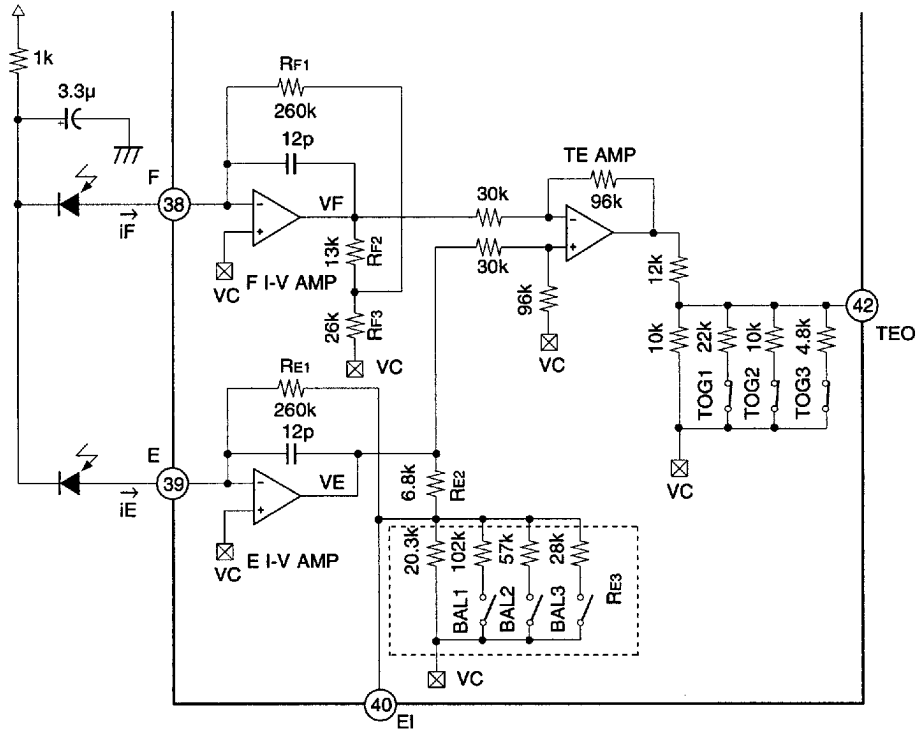

The CXA1782B tracking block has built-in circuits for balance and gain adjustments to enable software-based automatic adjustment.

The balance adjustment is performed by varying the combined resistance value of the T-configured feedback resistance at E I-V AMP.

$$\text{F I-V AMP feedback resistance} = R_{F1} + R_{F2} + \frac{R_{F1} \times R_{F2}}{R_{F3}} = 403k\Omega$$

$$\text{E I-V AMP feedback resistance} = R_{E1} + R_{E2} + \frac{R_{E1} \times R_{E2}}{R_{E3}}$$

Vary the value of RE3 in the formula above by using the balance adjustment switches (BAL1 to BAL3).

For the gain adjustment, resistance divide the TE AMP output with the gain adjustment switches (TOG1 to TOG3), and output at Pin 42.

These balance and gain adjustment switches are controlled through software commands.

Tracking Automatic Adjustment for Gain/Balance

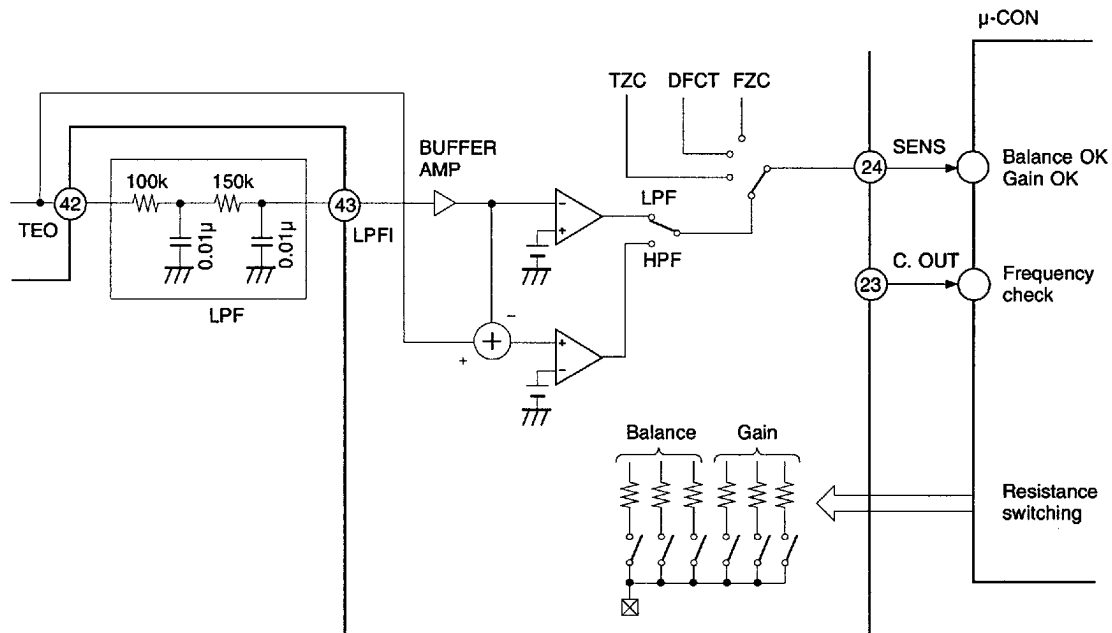

The CXA1782B has balance control, gain control, and comparator circuits required to perform tracking automatic adjustment. LPF is set externally at approximately 100Hz.

• Balance adjustment

This adjustment is performed by routing the tracking error signal (TE signal) through the LPF, extracting the offset DC, and comparing it to the reference level.

However, the TE signal frequency distribution ranges from DC to 2kHz. Merely sending the signal through the LPF leaves lower frequency components, and the complete DC offset can not be extracted. To extract it, monitor the TE signal frequency at all times, and perform adjustment only when, at minimum, a frequency that can lower a sufficient gain appears on the LPF. Use the C. OUT output to check this frequency.

• Gain adjustment

This adjustment is performed by routing the TE signal through the HPF and comparing the AC component to the reference level. The HPF is implemented by taking the difference between the TE signal and the LPF component input to Pin 43.

The comparison signal is output from Pin 24 (SENS). Address 3 selects the automatic adjustment comparator output, and HPF for data (D3) = "1" or LPF for data (D3) = "0" is selected.

• The anti-shock circuit always operates in the CXA1782B so that TG1 and TG2 (address 1 : D3) should be set to "1" for tracking adjustment to prevent this effect.

When the anti-shock function is not used, Pin 45 (ATSC) should be fixed to VC.

Center Voltage Generation Circuit

Maximum current is approximately $\pm 3\text{mA}$. Output impedance is approximately 50Ω

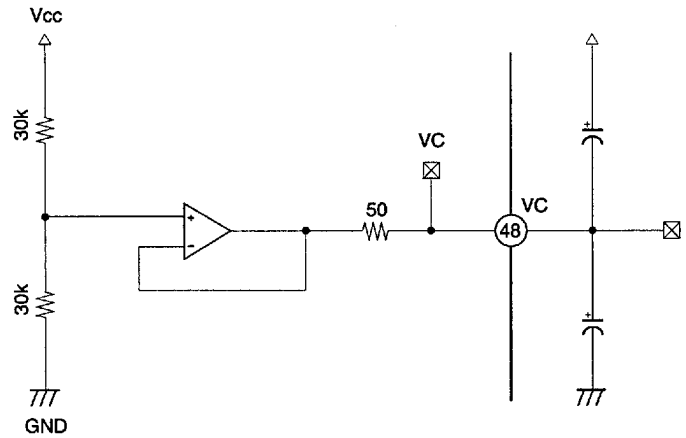

APC Circuit

When driving a constant current, the optical output by the laser diode possesses large negative temperature characteristics. Therefore, the current must be controlled with the monitor photo diode to ensure the output remains constant.

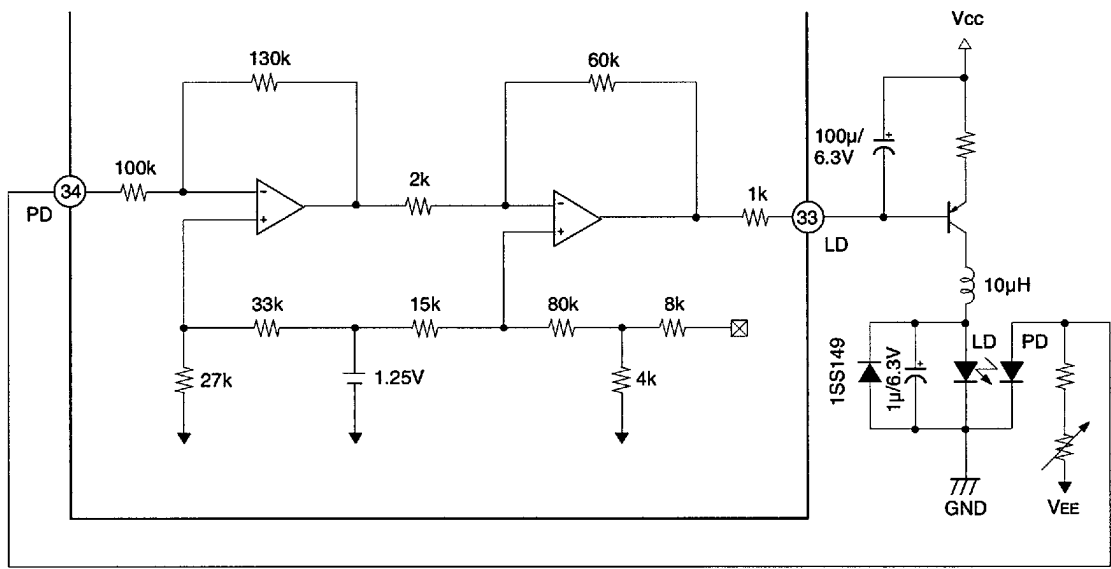

Focus Servo

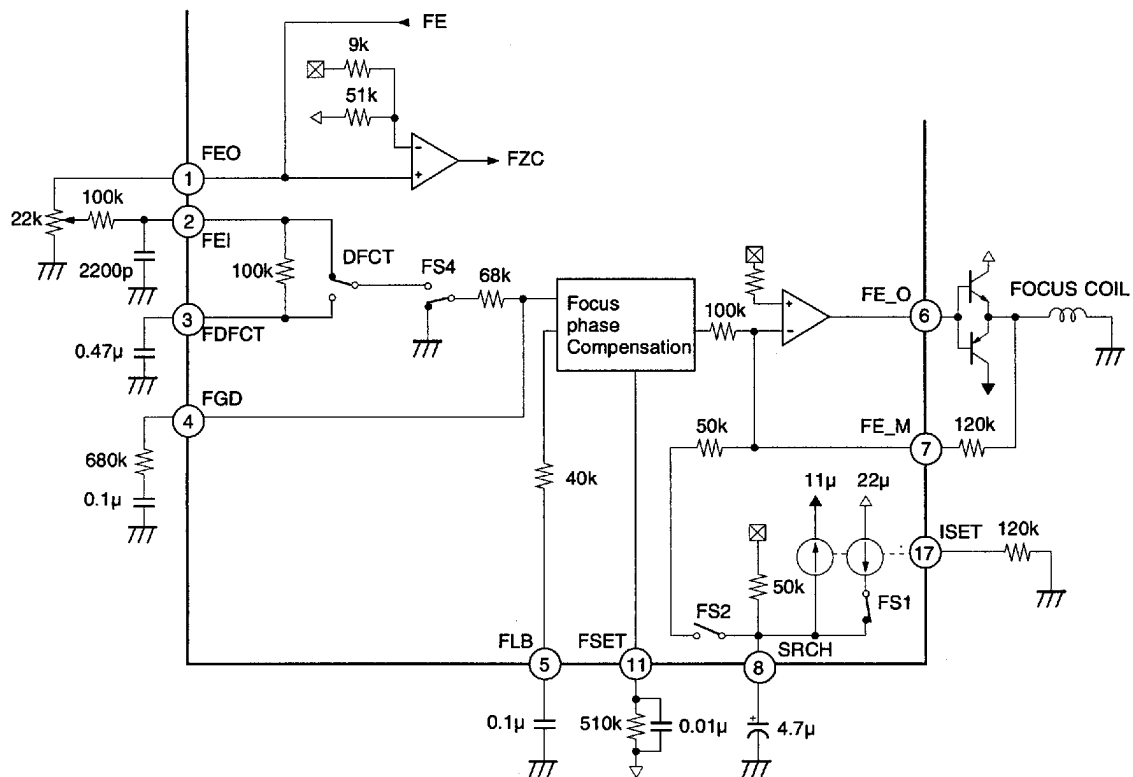

The above figure shows a block diagram of the focus servo.

Ordinarily the FE signal is input to the focus phase compensation circuit through a ~~68k~~ resistance; however, when DFCT is detected, the FE signal is switched to pass through a low-pass filter formed by the internal 100kΩ resistance and the capacitance connected to Pin 3. When this DFCT prevention circuit is not used, leave Pin 3 open. An additional note, defect switch operation can be enabled and disabled with command.

The capacitor connected between Pin 5 and GND is a time constant to raise the low frequency in the normal playback state.

The peak frequency of the focus phase compensation is approximately 1.2kHz when a resistance of ~~510k~~ is connected to Pin 11.

The focus search height is approximately $\pm 1.1V_{p-p}$ when using the constants indicated in the above figure. This height is inversely proportional to the resistance connected between Pin 17 and GND. However, changing this resistance also changes the height of the track jump and sled kick as well.

The FZC comparator inverted input is set to 15% of V_{CC} and V_C (Pin 48); $(V_{CC} - V_C) \times 15\%$.

Note 510kΩ resistance is recommended for Pin 11.

Tracking Sled Servo

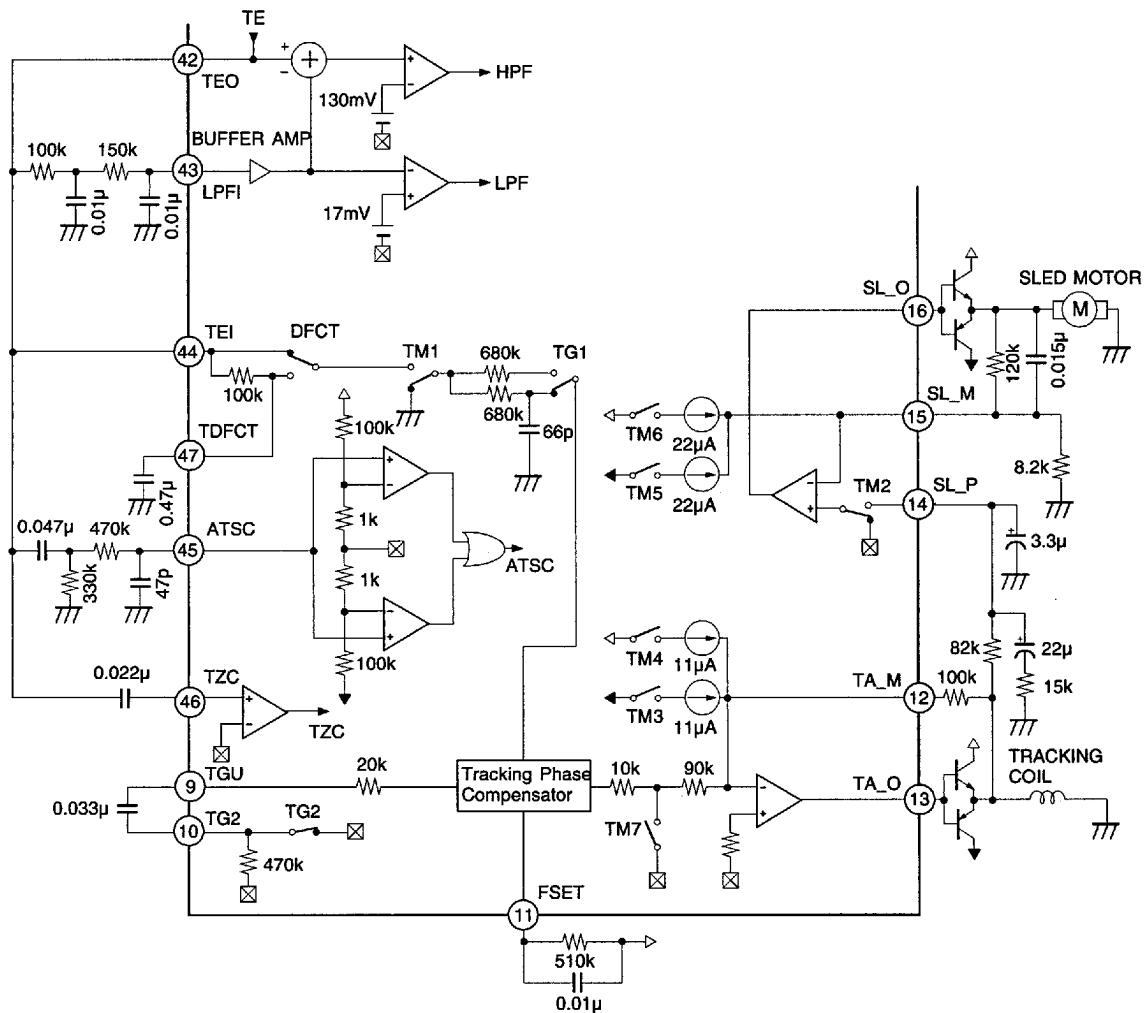

The above figure shows a block diagram of the tracking and sled servo.

The capacitor connected between Pins 9 and 10 is a time constant to decrease the high-frequency gain when TG2 is off. The peak frequency of the tracking phase compensation is approximately 1.2kHz when a 510k resistance connected to Pin 11. In the CXA1782B, TG1 and TG2 are inter-linked switches.

To jump tracks in FWD and REV directions, turn TM3 or TM4 on. During this time, the peak voltage applied to the tracking coil is determined by the TM3 or TM4 current and the feedback resistance from Pin 12. To be more specific,

$$\text{Track jump peak voltage} = \text{TM3 (or TM4) current} \times \text{feedback resistance value}$$

The FWD and REV sled kick is performed by turning TM5 or TM6 on. During this time, the peak voltage applied to the sled motor is determined by the TM5 or TM6 current and the feedback resistance from Pin 15;

$$\text{Sled jump peak voltage} = \text{TM5 (or TM6) current} \times \text{feedback resistance}$$

The values of the current for each switch are determined by the resistance connected between Pin 17 and GND. When this resistance is 120k:

$$\text{TM3 (or TM4)} = \pm 11\mu\text{A}, \text{ and TM5 (or TM6)} = \pm 22\mu\text{A}.$$

As is the case with the FE signal, the TE signal is switched to pass through a low-pass filter formed by the internal resistance (100k) and the capacitance connected to Pin 47.

Focus OK Circuit

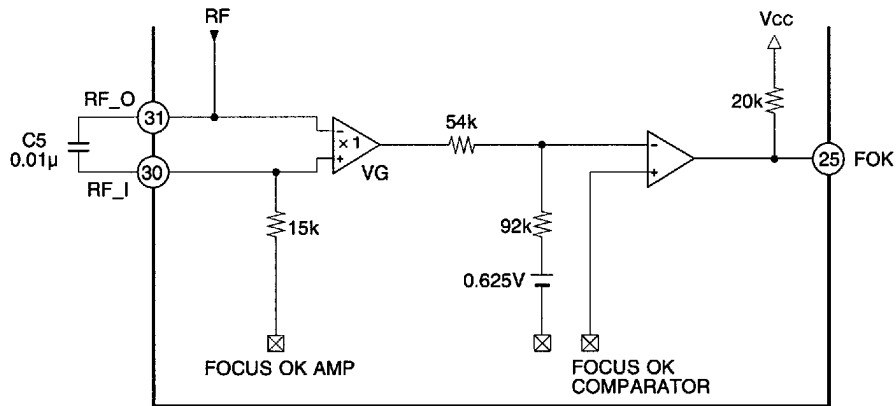

The focus OK circuit creates the timing window okaying the focus servo from the focus search state. The HPF output is obtained at Pin 30 from Pin 31 (RF signal), and the LPF output (opposite phase) of the focus OK amplifier output is also obtained. The focus OK output reverses when $V_{FI} - V_{RFO} \approx -0.37V$. Note that, C5 determines the time constant of the HPF for the EFM comparator and mirror circuit and the LPF of the focus OK amplifier. Ordinarily, with a C5 equal to 0.01µF selected, the f_c is equal to 1kHz, and block error rate degradation brought about by RF envelope defects caused by scratched discs can be prevented.

DEFECT Circuit

After the RFI signal is reversed, two time constants, long and short, are held at bottom. The short time constant bottom hold responds to 0.1ms or greater disc mirror defects, and the long time constant bottom hold holds the pre-defect mirror level. By differentiating and level shifting these constants with C coupling and comparing both signals, the mirror defect detection signal is generated.

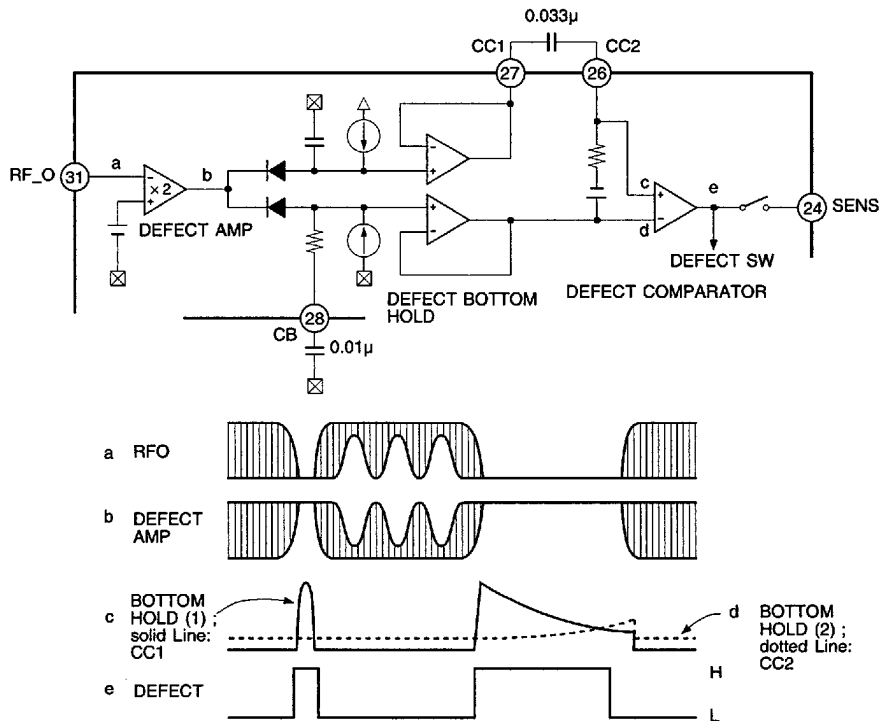

Mirror Circuit

The mirror circuit performs peak and bottom hold after the RFI signal has been amplified.

The peak and bottom holds are both held through the use of a time constant. For the peak hold, a time constant can follow a 30kHz traverse, and, for the bottom hold, one can follow the rotation cycle envelope fluctuation.

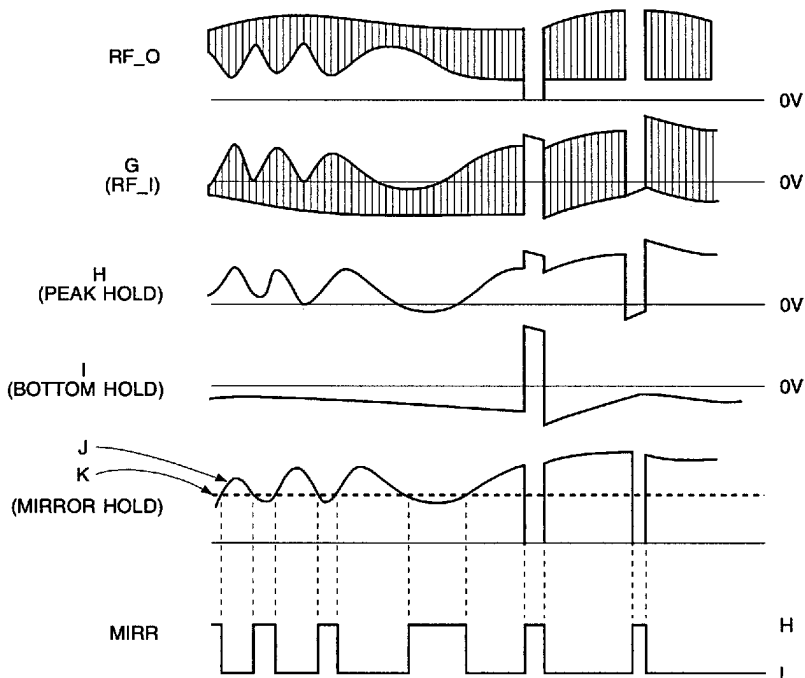
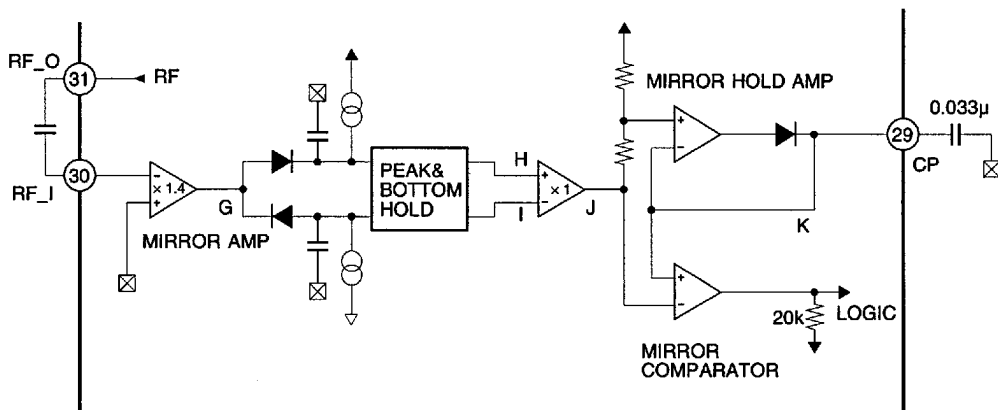

The DC playback envelope signal J is obtained by amplifying the difference between the peak and bottom hold signals H and I. Signal J has a large time constant of 2/3 its peak value, and the mirror output is obtained by comparing it to the peak hold signal K. Accordingly, when on the disc track, the mirror output is Low; when between tracks (mirrored portion), it is High; and when a defect is detected, it is High. The mirror hold time constant must be sufficiently large compared with the traverse signal.

In the CXA1782B, this mirror output is used only during braking operations, and no external output pin is attached. Accordingly, when connecting DSP such as the CXD2500 with MIRR input pin, input the C. OUT output to the MIRR input of the DSP.

Commands

The input data to operate this IC is configured as 8-bit data; however, below, this input data is represented by 2-digit hexadecimal numerals in the form \$XX, where X is a hexadecimal numeral between 0 and F. Commands for the CXA1782B can be broadly divided into four groups ranging in value from \$0X to \$3X.

1. \$0X ("FZC" at SENS pin (Pin 24))

These commands are related to focus servo control. The bit configuration is as shown below.

D7	D6	D5	D4	D3	D2	D1	D0
0	0	0	0	FS4	DEFECT	FS2	FS1

Four focus-servo related switches exist: FS1, FS2, FS4, and DEFECT corresponding to D0 to D3, respectively.

\$00 When FS1 = 0, Pin 8 is charged to $(22\mu\text{A} - 11\mu\text{A}) \times 50\text{k}\Omega = 0.55\text{V}$.

If, in addition, FS2 = 0, this voltage is no longer transferred, and the output at Pin 6 becomes 0V.

\$02 From the state described above, the only FS2 becomes 1. When this occurs, a negative output is output at Pin 6. This voltage level is obtained by equation 1 below.

$$(22\mu\text{A} - 11\mu\text{A}) \times 50\text{k}\Omega \times \frac{\text{resistance between Pins 6 and 7}}{50\text{k}\Omega} \dots\dots\dots \text{Equation 1}$$

\$03 From the state described above, FS1 becomes 1, and a current source of +22μA is split off. Then, a CR charge/discharge circuit is formed, and the voltage at Pin 8 decreases with the time as shown in Fig. 1 below.

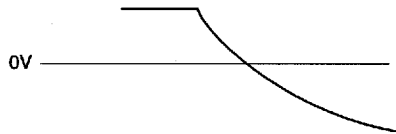

Fig. 1. Voltage at Pin 8 when FS1 goes from 0 → 1

This time constant is obtained with the 50kΩ resistance and an external capacitor.

By alternating the commands between \$02 and \$03, the focus search voltage can be constructed. (Fig. 2)

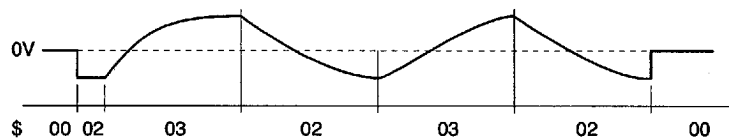

Fig. 2. Constructing the search voltage by alternating between \$02 and \$03. (Voltage at Pin 6)

\$04 When the fact that the RF signal is missing is detected and scratches on the disc are detected with DEFECT = 0, DFCT (FS3) is turned ON.

1-1. FS4

This switch is existed between the focus error input (Pin 2) and the focus phase compensation, and is in charge of turning the focus servo on and off.

\$00 → \$08
 Focus off ← Focus on

1-2. Procedure of focus activation

For description, suppose that the polarity is as described below.

- a) The lens is searching the disc from far to near;
- b) The output voltage (Pin 6) is changing from negative to positive; and
- c) The focus S-curve is varying as shown below.

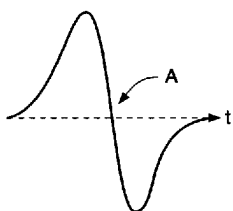

Fig. 3. S-curve

The focus servo is activated at the operating point indicated by A in Fig. 3. Ordinarily, focus searching and the turning the focus servo switch on are performed during the focus S-curve transits the point A indicated in Fig. 3. To prevent misoperation furthermore, this signal is ANDed with the focus OK signal.

In this IC, FZC (Focus Zero Cross) signal is output from the SENS pin (Pin 24) as the point A transit signal. In addition, focus OK is output as a signal indicating that the signal is in focus (can be in focus in this case).

Following the line of the above description, focusing can be well obtained by observing the following timing chart.

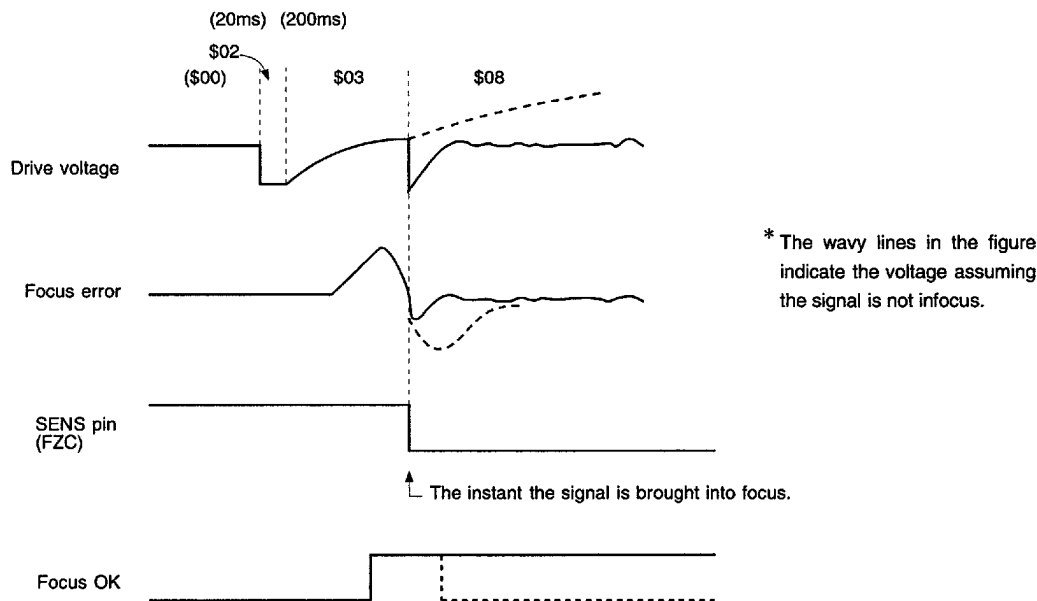

Fig. 4. Focus ON timing chart

Note that the time from the High to Low transition of FZC to the time command \$08 is asserted must be minimized. To do this, the software sequence shown in B is better than the sequence shown in A.

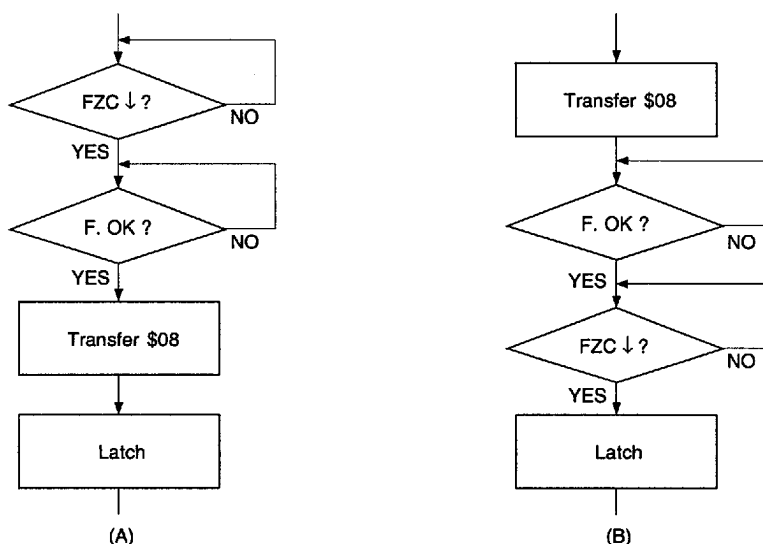

Fig. 5. Poor and good software command sequences

1-3. SENS pin (Pin 24)

The output of the SENS pin differs depending on the input data as shown below.

- \$0X: FZC
- \$1X: DEFECT
- \$2X: TZC
- \$3X: Automatic adjustment comparator output
- \$4X to 7X: HIGH-Z

2. \$1X ("DEFECT" at SENS pin (Pin 24))

These commands deal with switching TG1/TG2, brake circuit ON/OFF, and the sled kick output.

The bit configuration is as follows

D7	D6	D5	D4	D3	D2	D1	D0
0	0	0	1	TG1, TG2	Break circuit	Sled kick height	
				ON/OFF	ON/OFF		

Sled kick height		Relative value
D1 (PS1)	D0 (PS0)	
0	0	±1
0	1	±2
1	0	Don't use
1	1	

TG1, TG2

The purpose of these switches is to switch the tracking servo gain Up/Normal. TG1 and TG2 are interlinked switches. The brake circuit (TM7) is to prevent the occurrence of such frequently occurring phenomena as extremely degraded actuator settling due to the servo motor exceeding the linear range causing what should be a 100-track jump to fall back down to a 10-track jump after a 100 or 10-track jump has been performed. To do this, when the actuator travels radially; that is, when it traverses from the inner track to the outer track of the disc and vice versa, the brake circuit utilizes the fact that the phase relationship between the RF envelope and the tracking error is 180° out-of-phase to cut the unneeded portion of the tracking error and apply braking.

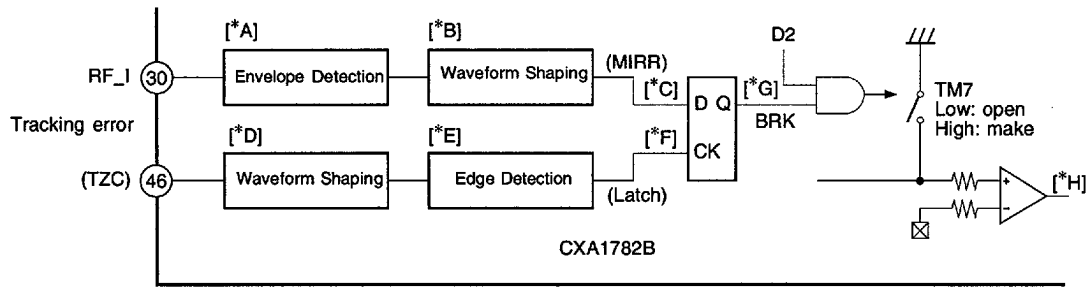

Fig. 6. TMI movement during braking operation

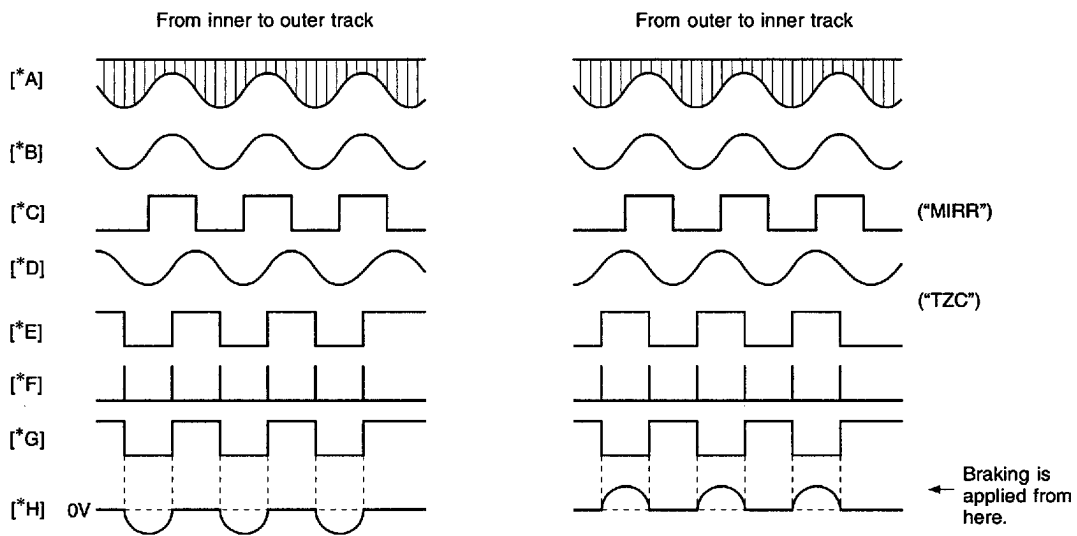

Fig. 7. Internal waveform

3. \$2X ("TZC" at SENS pin (Pin 24))

These commands deal with turning the tracking servo and sled servo ON/OFF, and creating the jump pulse and fast forward pulse during access operations.

D7	D6	D5	D4	D3	D2	D1	D0
0	0	1	0	Tracking control		Sled control	
				00: OFF		00: OFF	
				01: Servo ON		01: Servo ON	
				10: F-JUMP		10: F-FAST FORWARD	
				11: R-JUMP		11: R-FAST FORWARD	
				↓		↓	
				TM1, TM3, TM4		TM2, TM5, TM6	

4. \$3X

These commands control the balance and gain control circuit switches used during automatic tracking adjustment.

All these switches in the initial resetting state aer ON.

• Balance adjustment

The balance adjustment switches BAL1 to BAL3 can be controlled by setting D3 = 0. The switches are set using D0 to D2.

At this time, the balance adjustment LPF comparator output is selected at the SENS pin.

Data is D3 = 0 and it is set by specifying switch conditions D0 to D2 and sending a latch pulse.

Sending a latch pulse when D3 = 1 does not change the balance switch settings.

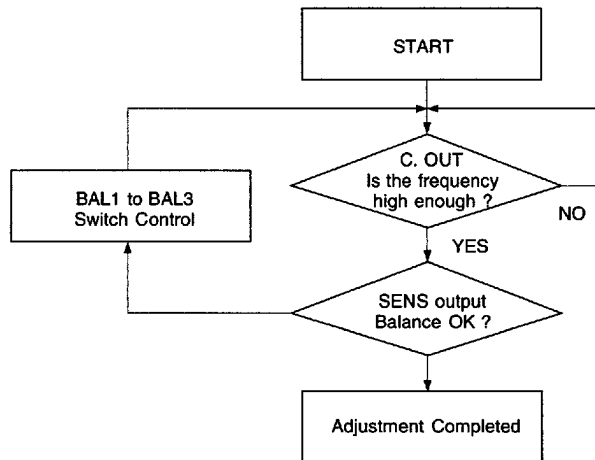

Balance adjustment

• Gain adjustment

The gain adjustment switches TOG1 to TOG3 can be controlled by setting D3 = 1. These switches are set using D0 to D2. At this time, the balance adjustment HPF comparator output is selected for SENS pin.

In a fashion similar to the method used with the balance adjustment, set the data by sending a latch pulse with D3 = 1, specifying the switch conditions D0 to D2.

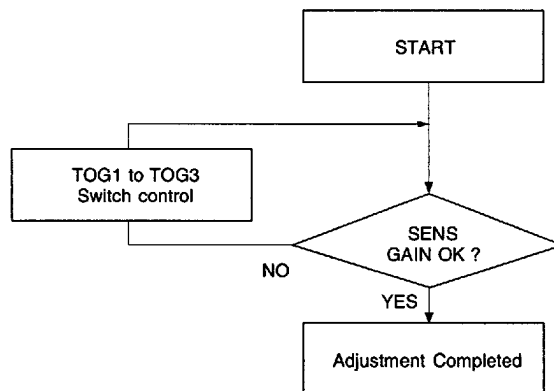

Gain adjustment

CPU Serial Interface Timing Chart

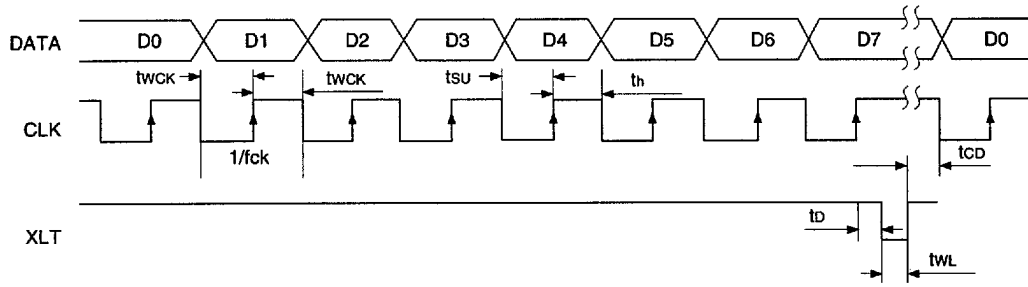

(Vcc = 3.0V)

Item	Symbol	Min.	Type.	Max.	Unit
Clock frequency	fck			1	MHz
Clock pulse width	fwck	500			ns
Setup time	tsu	500			ns
Hold time	th	500			ns
Delay time	td	500			ns
Latch pulse width	twl	1000			ns
Data transfer interval	tcd	1000			ns

System Control

Item	ADDRESS				DATA				SENS output
	D7	D6	D5	D4	D3	D2	D1	D0	
Focus Control	0	0	0	0	FS4 Focus ON = 1, OFF = 0	DEFECT (FS3) Disable = 1 Enable = 0	FS2 Search ON = 1, OFF = 0	FS1 Search Up = 1, Down = 0	FZC
Tracking Control	0	0	0	1	TG1, TG2 ON = 1, OFF = 0	Brake ON = 1, OFF = 0	Sled Kick + 2	Sled Kick + 1	DEFECT
Tracking Mode	0	0	1	0	Tracking Mode *1		Sled Mode *2		TZC
Select	0	0	1	1	Automatic tracking adjustment mode				Gain/Bal

*1 TRACKING MODE

	D3	D2
OFF	0	0
ON	0	1
FWD JUMP	1	0
REV JUMP	1	1

*2 SLED MODE

	D1	D0
OFF	0	0
ON	0	1
FWD MOVE	1	0
REV MOVE	1	1

Serial Data Truth Table

Serial Data	Hex	Functions			
FOCUS CONTROL		FS = 4321			
		FS4	DEFECT	FS2	FS1
0 0 0 0 0 0 0 0	\$00	0	E	0	0
0 0 0 0 0 0 0 1	\$01	0	E	0	1
0 0 0 0 0 0 1 0	\$02	0	E	1	0
0 0 0 0 0 0 1 1	\$03	0	E	1	1
0 0 0 0 0 1 0 0	\$04	0	D	0	0
0 0 0 0 0 1 0 1	\$05	0	D	0	1
0 0 0 0 0 1 1 0	\$06	0	D	1	0
0 0 0 0 0 1 1 1	\$07	0	D	1	1
0 0 0 0 1 0 0 0	\$08	1	E	0	0
0 0 0 0 1 0 0 1	\$09	1	E	0	1
0 0 0 0 1 0 1 0	\$0A	1	E	1	0
0 0 0 0 1 0 1 1	\$0B	1	E	1	1
0 0 0 0 1 1 0 0	\$0C	1	D	0	0
0 0 0 0 1 1 0 1	\$0D	1	D	0	1
0 0 0 0 1 1 1 0	\$0E	1	D	1	0
0 0 0 0 1 1 1 1	\$0F	1	D	1	1

DEFECT
E: enable
D: disable

TRACKING MODE	Hex	TM = 6 5 4 3 2 1
0 0 1 0 0 0 0 0	\$20	0 0 0 0 0 0
0 0 1 0 0 0 0 1	\$21	0 0 0 0 1 0
0 0 1 0 0 0 1 0	\$22	0 1 0 0 0 0
0 0 1 0 0 0 1 1	\$23	1 0 0 0 0 0
0 0 1 0 0 1 0 0	\$24	0 0 0 0 0 1
0 0 1 0 0 1 0 1	\$25	0 0 0 0 1 1
0 0 1 0 0 1 1 0	\$26	0 1 0 0 0 1
0 0 1 0 0 1 1 1	\$27	1 0 0 0 0 1
0 0 1 0 1 0 0 0	\$28	0 0 0 1 0 0
0 0 1 0 1 0 0 1	\$29	0 0 0 1 1 0
0 0 1 0 1 0 1 0	\$2A	0 1 0 1 0 0
0 0 1 0 1 0 1 1	\$2B	1 0 0 1 0 0
0 0 1 0 1 1 0 0	\$2C	0 0 1 0 0 0
0 0 1 0 1 1 0 1	\$2D	0 0 1 0 1 0
0 0 1 0 1 1 1 0	\$2E	0 1 1 0 0 0
0 0 1 0 1 1 1 1	\$2F	1 0 1 0 0 0

Automatic adjustment mode		TOG SW	BAL SW
	Hex	3 2 1	3 2 1
0 0 1 1 0 0 0 0	\$30	---	1 1 1
0 0 1 1 0 0 0 1	\$31	---	1 1 0
0 0 1 1 0 0 1 0	\$32	---	1 0 1
0 0 1 1 0 0 1 1	\$33	---	1 0 0
0 0 1 1 0 1 0 0	\$34	---	0 1 1
0 0 1 1 0 1 0 1	\$35	---	0 1 0
0 0 1 1 0 1 1 0	\$36	---	0 0 1
0 0 1 1 0 1 1 1	\$37	---	0 0 0
0 0 1 1 1 0 0 0	\$38	1 1 1	---
0 0 1 1 1 0 0 1	\$39	1 1 0	---
0 0 1 1 1 0 1 0	\$3A	1 0 1	---
0 0 1 1 1 0 1 1	\$3B	1 0 0	---
0 0 1 1 1 1 0 0	\$3C	0 1 1	---
0 0 1 1 1 1 0 1	\$3D	0 1 0	---
0 0 1 1 1 1 1 0	\$3E	0 0 1	---
0 0 1 1 1 1 1 1	\$3F	0 0 0	---

DATA D3 = 0: Balance switch setting
 DATA D3 = 1: Gain switch setting

Note) 0 means OFF and 1 means ON for TOG SW and BAL SW. These are not equal to the setting values of each bit for serial data.

Notes on Operation

1. FSET pin

The FSET pin determines the f_c for the focus and tracking high-frequency phase compensation.

2. ISET pin

ISET current = $1.27V/R$
 = Focus search current
 = Tracking jump current
 = Sled kick current (\$1X: PS1 = PS0 = 0) $\times \frac{1}{2}$

Use the setting resistance within the range of 120k Ω to 240k Ω . As for sled kick current, ± 2 or less is used for the relative value.

3. FE/TE gain changing method

- 1) High gain : Resistance between FE Pins (Pin 6 and 7) 100k Ω \rightarrow Large
 Resistance between TE Pins (Pin 12 and 13) 100k Ω \rightarrow Large
- 2) Low gain : A signal, whose resistance is divided between Pins 1 and 2, is input to FE. The internal gain adjustment circuit is used for TE.

4. Input voltage at Pins 19 to 22 of the microcomputer interface:

Apply
 $V_{IH} V_{CC} \times 90\%$ or more
 $V_{IL} V_{CC} \times 10\%$ or less

5. Focus OK circuit

- 1) Refer to the "Description of Operation" for the time constant setting of the focus OK amplifier LPF and the mirror amplifier HPF.
- 2) The equivalent circuit of the focus OK output pin (FOK) is as shown below.

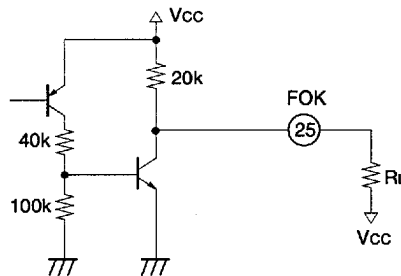

The FOK and comparator output are as follows:

Output voltage High: $V_{FOKH} \approx \text{nearly } V_{CC}$
 Output voltage Low: $V_{FOKL} \approx V_{sat}$ (NPN)

6. Sled amplifier

The sled amplifier may oscillate when used by the buffer amplifier. Use with a gain of approximately 20dB.

Focus/Tracking internal phase compensation and reference design material

	Item	SD	Measurement pin	Conditions	Typ.	Unit
FCS	1.2kHz gain	08	6	$C_{FLB} = 0.1\mu F$ $C_{FGD} = 0.1\mu F$	21.5	dB
	1.2kHz phase	08			63	deg
TRK	1.2kHz gain	25	13	$C_{TGU} = 0.1\mu F$	13	dB
	1.2kHz phase	25			-125	deg
	2.7kHz gain	25 \rightarrow 13			26.5	dB
	2.7kHz phase	25 \rightarrow 13			-130	deg

Package Outline Unit: mm

CXA1782BQ

48PIN QFP (PLASTIC)

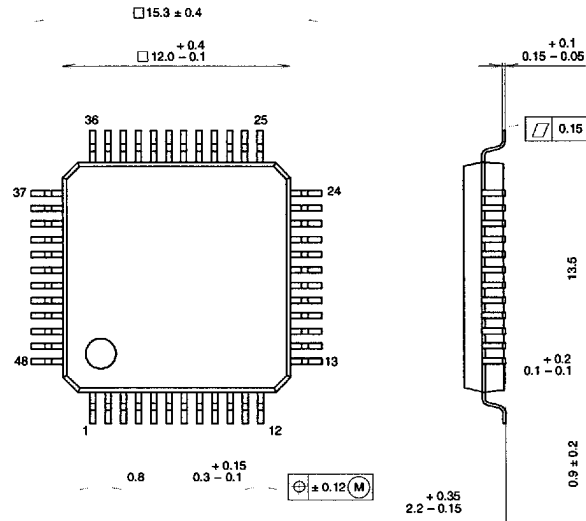

PACKAGE STRUCTURE

SONY CODE	QFP-48P-L04
EIAJ CODE	*QFP048-P-1212-B
JEDEC CODE	

PACKAGE MATERIAL	EPOXY RESIN
LEAD TREATMENT	SOLDER / PALLADIUM PLATING
LEAD MATERIAL	COPPER / 42 ALLOY
PACKAGE WEIGHT	0.7g

CXA1782BR

48PIN LQFP (PLASTIC)

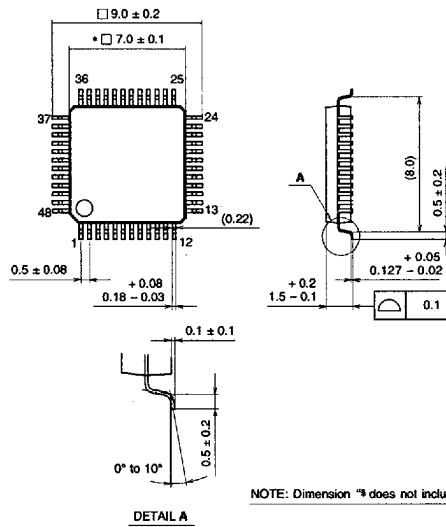

NOTE: Dimension "A" does not include mold protrusion.

PACKAGE STRUCTURE

SONY CODE	LQFP-48P-L01
EIAJ CODE	*QFP048-P-0707-A
JEDEC CODE	

PACKAGE MATERIAL	EPOXY / PHENOL RESIN
LEAD TREATMENT	SOLDER PLATING
LEAD MATERIAL	42 ALLOY
PACKAGE WEIGHT	0.2g