

**Stereo Pre-Amplifier/Power-Amplifier with 3V Governor****For the availability of this product, please contact the sales office.****Description**

The CXA1635S/M is an IC designed for 3V headphone stereo, and provides all functions required for a headphone stereo on a single chip.

**Features**

- Output capacitors are not required
- Built-in bass boost function (10dB at 125Hz Typ.)
- Built-in motor speed controller
- Few external parts
- Wide operating supply voltage range (1.8 to 4.5V)

**Absolute Maximum Ratings (Ta=25°C)**

- Supply voltage Vcc 7 V
- Operating temperature Topr -20 to +75 °C
- Storage temperature Tstg -65 to +150 °C
- Allowable power dissipation
 

P <sub>D</sub> (CXA1635S)	880	mW
(CXA1635M)	570	mW

**Operating Conditions**

- Supply voltage Vcc 1.8 to 4.5 V

CXA1635S  
22 pin SDIP (Plastic)

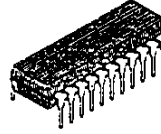

CXA1635M  
24 pin SOP (Plastic)

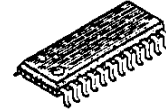
**Applications**

3V headphone stereos

**Structure**

Bipolar silicon monolithic IC

Sony reserves the right to change products and specifications without prior notice. This information does not convey any license by any implication or otherwise under any patents or other right. Application circuits shown, if any, are typical examples illustrating the operation of the devices. Sony cannot assume responsibility for any problems arising out of the use of these circuits.

Block Diagram

CXA1635S

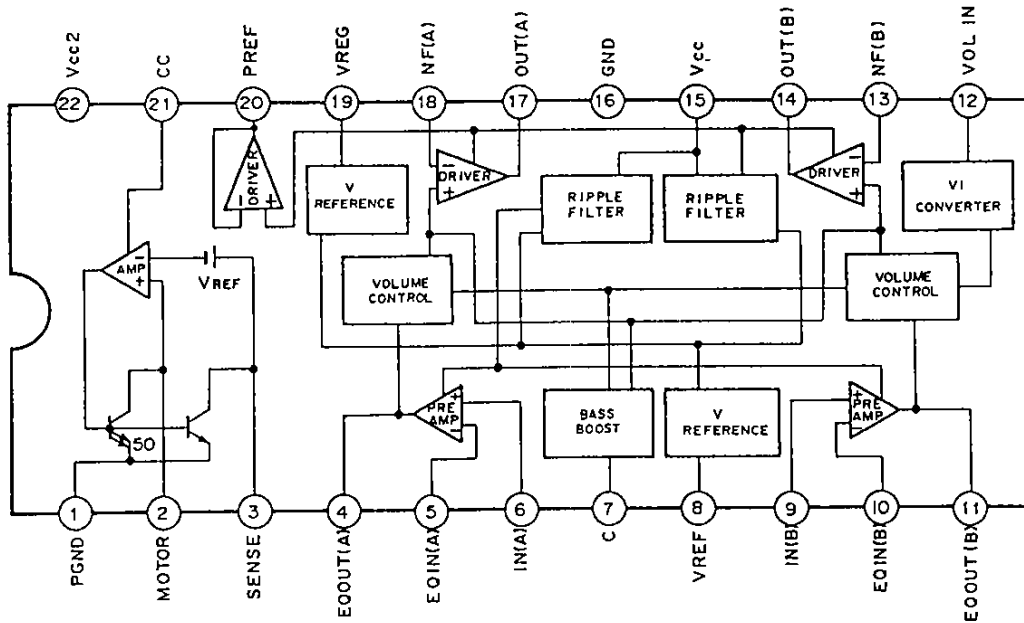

CXA1635M

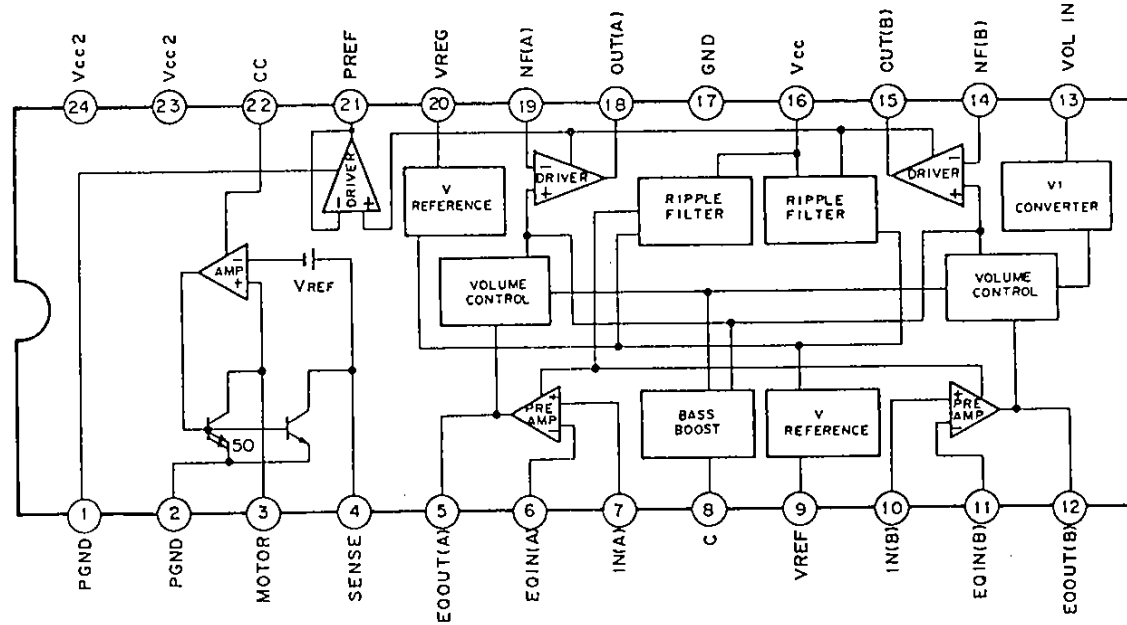

Pin Description

(Vcc=3V at no signal; pin numbers in brackets are for the CXA1635M.)

Pin No.	Symbol	Pin voltage	Equivalent circuit	Description
1 (1, 2)	PGND	0V		GND for governor block.
2 (3)	MOTOR			Motor connection.
3 (4)	SENSE			Sense resistance connection.
4 (5) 11 (12)	EQOUT (A) EQOUT (B)	1.5V		Pre-amplifier output/equalizer element connection.
5 (6) 10 (11)	EQIN (A) EQIN (B)	1.5V		Equalizer element connection.

Pin No.	Symbol	Pin voltage	Equivalent circuit	Description
6 (7) 9 (10)	IN (A) IN (B)	1.5V		Pre-amplifier input.
7 (8)	C	1.5V		Bass boost capacitance connection.
8 (9)	VREF	1.5V		Reference bias voltage output.
12 (13)	VOLIN			Volume control voltage input.

Pin No.	Symbol	Pin voltage	Equivalent circuit	Description
13 (14) 18 (19)	NF (A) NF (B)	1.5V		Filter capacitance connection for headphone driver.
14 (15) 17 (18) 20 (21)	OUT (A) OUT (B) PREF	1.5V		Headphone driver output.  (The pin voltages of OUT (A) and OUT (B) vary to approximately 1.6V, depending on the control voltage of Pin 12.)
15 (16)	Vcc	3.0V		Power supply.
16 (17)	GND	0.0V		GND
19 (20)	VREG	2.76V		Power supply filter.
21 (22)	CC	2.3V		Phase compensation capacitance connection for motor speed controller.
22 (23, 24)	Vcc2	3V		Power supply for governor block.

## Electrical Characteristics

(Ta=25°C, Vcc=3.0V, RL=32Ω; for switch settings, refer to the switch status table.)

	Item	Symbol	Measurement conditions	Min.	Typ.	Max.	Unit
Audio block							
1	Current consumption	I <sub>CC</sub>	No signal	6	11	15	mA
2	Voltage gain 1	G <sub>V1</sub>	V <sub>IN</sub> =-75dBm	62	64	68	dB
3	Voltage gain 2	G <sub>V2</sub>	V <sub>IN</sub> =-75dBm, vol=50%	51	55	58	dB
4	Voltage gain 3	G <sub>V3</sub>	V <sub>IN</sub> =-75dBm, BB ON	62	65	69	dB
5	Channel balance 1	Δ G <sub>V1</sub>	(G <sub>V1</sub> channel differential)	-1.5	0	1.5	dB
6	Channel balance 2	Δ G <sub>V2</sub>	(G <sub>V2</sub> channel differential)	-1.5	0	1.5	dB
7	Channel balance 3	Δ G <sub>V3</sub>	(G <sub>V3</sub> channel differential)	-1.5	0	1.5	dB
8	Maximum volume attenuation	V <sub>MIN</sub>	V <sub>IN</sub> =-65dBm	51	64	—	dB
9	Maximum output	P <sub>OMAX</sub>	THD=10%	24	35	—	mW
10	Distortion factor 1	THD1	V <sub>IN</sub> =-70dBm	—	0.7	1.2	%
11	Distortion factor 2	THD2	V <sub>IN</sub> =-60dBm, vol=50%	—	0.5	1.0	%
12	Noise output	V <sub>ND</sub>	V <sub>IN</sub> : R <sub>g</sub> =2kΩ termination A-weight filter	—	-56	-47	dBm
13	Ripple output	V <sub>R</sub>	V <sub>CC</sub> =2.5V, Δ V <sub>R</sub> =-30dBm	—	-53	-44	dBm
14	Cross talk between channels (A ↔ B)	V <sub>CT</sub>	A (B): V <sub>IN</sub> =-65dBm B (A): V <sub>IN</sub> =R <sub>g</sub> =2kΩ termination	—	-45	-40	dBm
Governor block							
15	Internal reference voltage for governor block	Δ V	I <sub>m</sub> =100mA		1.00		V
16	Proportional constant	K	I <sub>m</sub> =100mA ± 10mA		50		—

**Notes:** The input levels (V<sub>IN</sub>) indicated in the measurement conditions are specified for each input pin.

The input signal frequencies are all 1kHz and vol=100% is assumed when no conditions was specified.

## Switch Statuses (When not specified, the switch is off.)

		1	2	3	4	5	6	7	8	9	10	11	Input pins	Test pins
Item	Switch name	V c c	A C V	I c c	V R	B B	I N (A)	I N (B)	R L	C C	M O T O R	A f f i l t		
Audio block														
1	Current consumption	1	1		1	2	2	1		ON				V1
2	Voltage gain 1	1	1 2	ON	1	2	1 2	1 2	ON	ON			IN (A) IN (B)	OUT (A) OUT (B)
3	Voltage gain 2	1	1 2	ON	2	2	1 2	1 2	ON	ON			IN (A) IN (B)	OUT (A) OUT (B)
4	Voltage gain 3	1	1 2	ON	1	1	1 2	1 2	ON	ON			IN (A) IN (B)	OUT (A) OUT (B)
5	Channel balance 1													
6	Channel balance 2													
7	Channel balance 3													
8	Maximum volume attenuation	1	1 2	ON	3	2	1 2	1 2	ON	ON			IN (A) IN (B)	OUT (A) OUT (B)
9	Maximum output	1	1 2	ON	1	2	1 2	1 2	ON	ON			IN (A) IN (B)	OUT (A) OUT (B)
10	Distortion factor 1	1	1 2	ON	1	2	1 2	1 2	ON	ON			IN (A) IN (B)	OUT (A) OUT (B)
11	Distortion factor 2	1	1 2	ON	2	2	1 2	1 2	ON	ON			IN (A) IN (B)	OUT (A) OUT (B)
12	Noise output	1	1 2	ON	1	2	1 2	1 2	ON	ON		ON		OUT (A) OUT (B)
13	Ripple output	2	1 2	ON	1	2	1 2	1 2	ON	ON			Vcc	OUT (A) OUT (B)
14	Cross talk between channels A → B B → A	1	2 1	ON	1	2	1 2	1 2	ON	ON			IN (A) IN (B)	OUT (A) OUT (B)
Governor block														
15	Internal reference voltage for governor block	1	1	ON	3	1	2	1	ON		1			
16	Proportional constant	1	1		ON	1	2	1	ON		2 3			





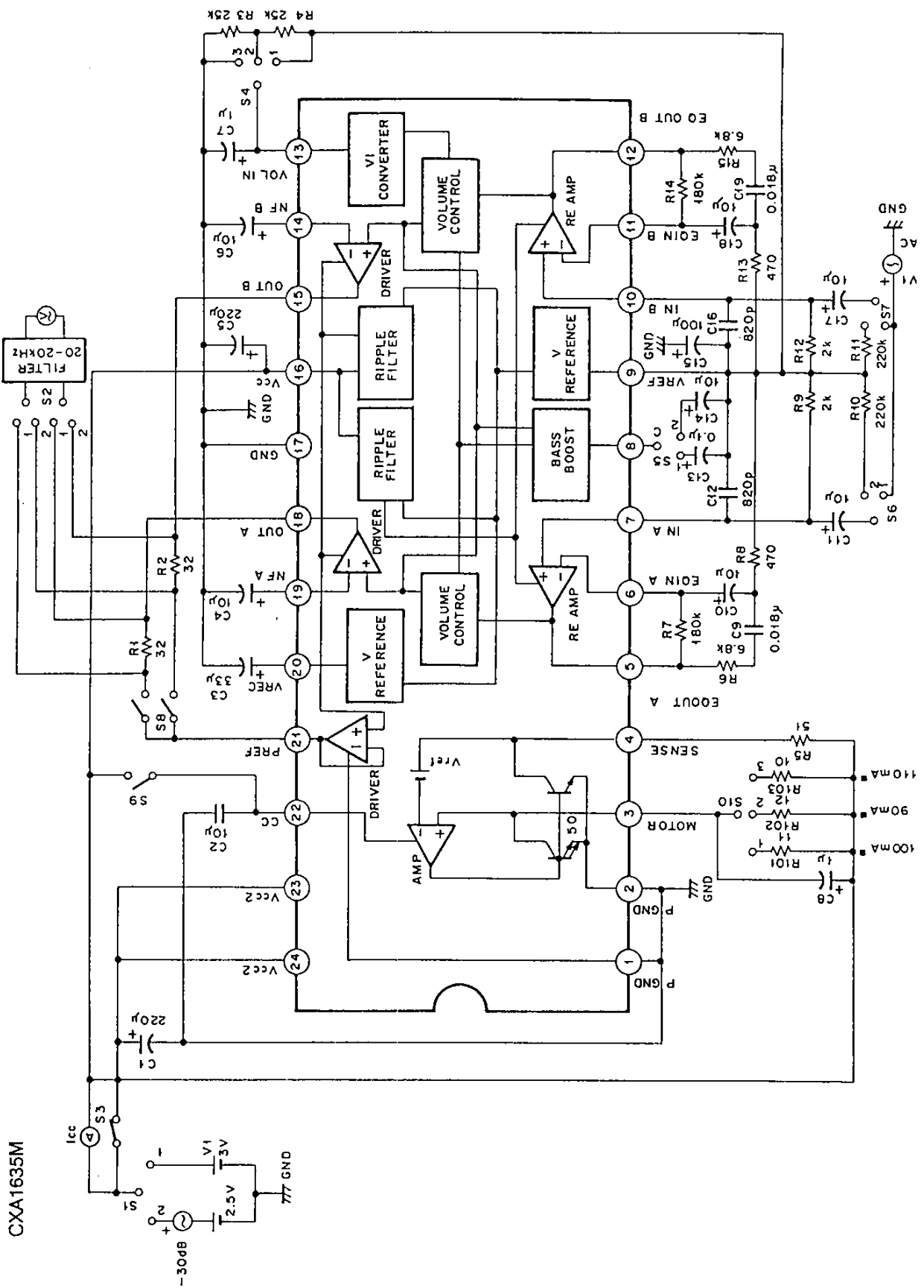

CXA1635M

Application Circuit

Pocketable headphone stereo player with radio

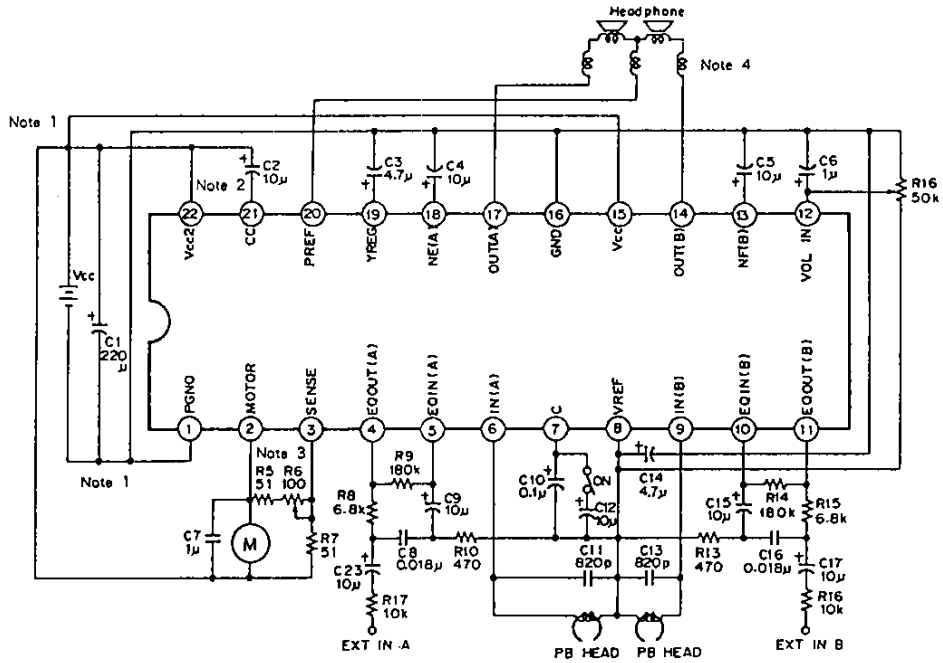

Pocketable headphone stereo player

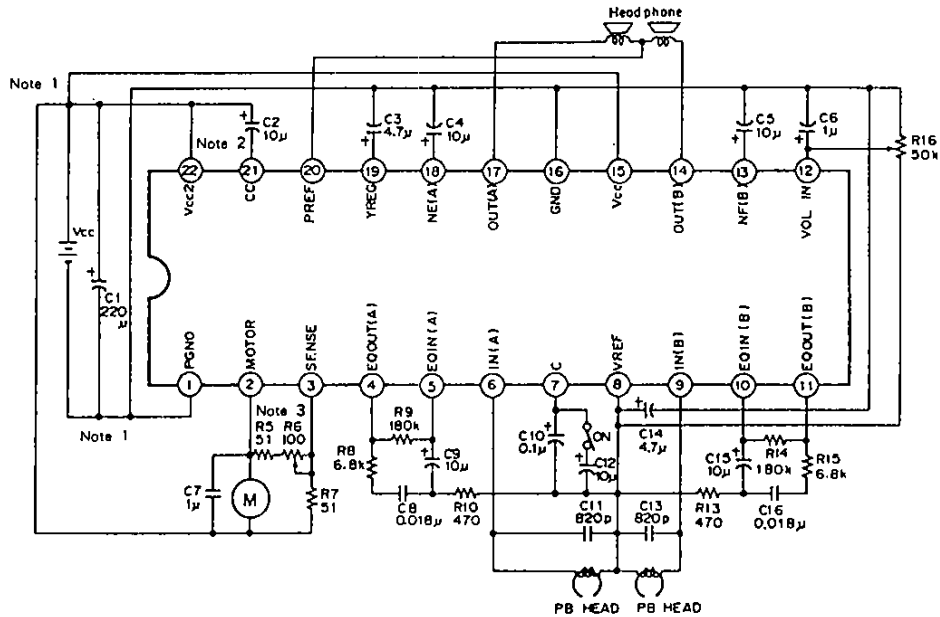

Stereo cassette player with 8 Ω speaker

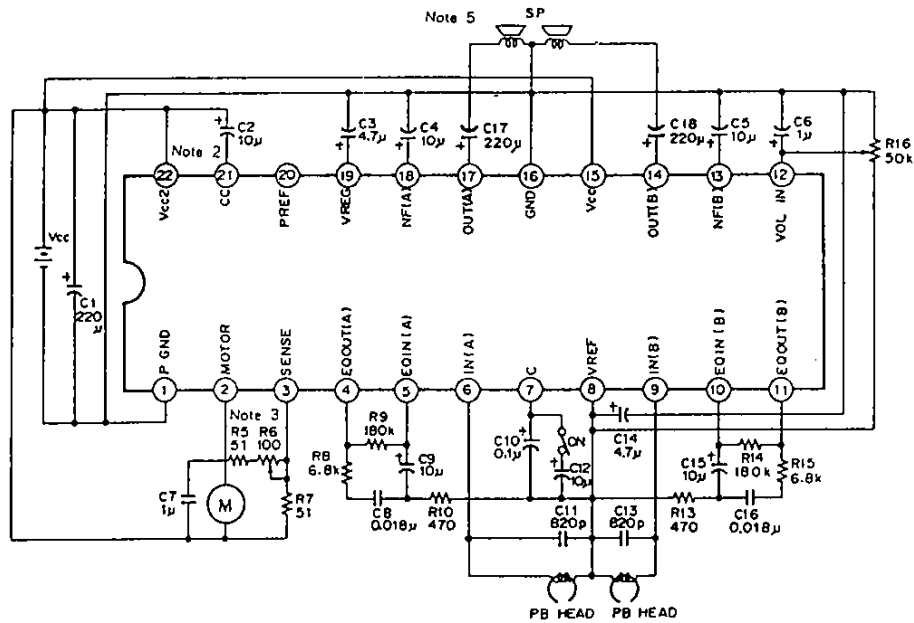

Note 1) The pattern layout of Vcc and GND, should be separated audio and motor speed controller blocks independently and then be connected at one point.

Note 2) Select a capacitor for phase compensation of the motor control circuit that makes ripple to a minimum.

Note 3) Select a resistor for motor speed control according to the motor.

Note 4) Connect coils when radiation countermeasures are required.

Note 5) Capacitor should be coupled as shown in the diagram when using 8 Ω speaker.

Application circuits shown are typical examples illustrating the operation of the devices. Sony cannot assume responsibility for any problems arising out of the use of these circuits or for any infringement of third party patent and other right due to same.

Examples of Representative Characteristics

Maximum output vs. Vcc characteristics (8 Ω load)  
( $f_o=1\text{kHz}$ , THD=10%,  $R_L=8\ \Omega$ )

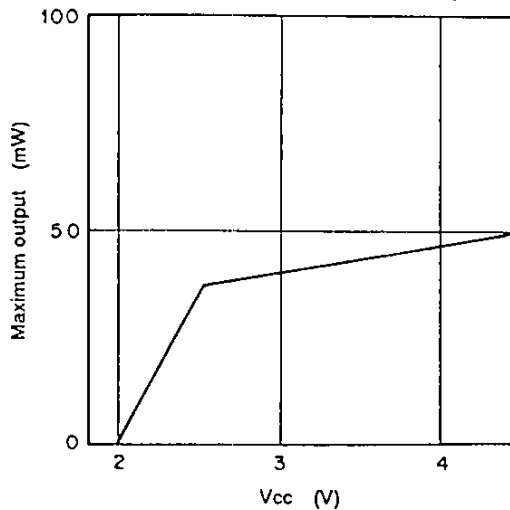

Examples of Representative Characteristics

Circuit current (at no signal)

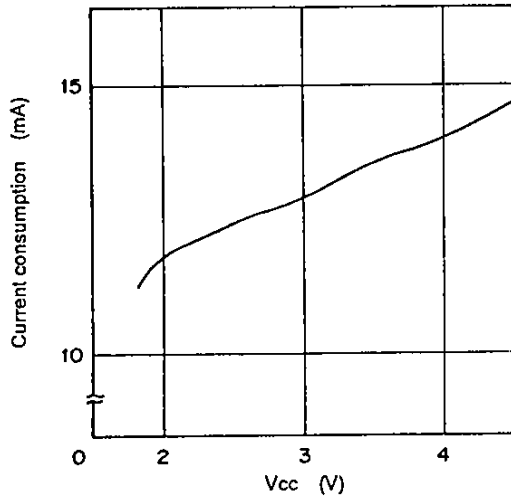

Volume attenuation vs. Control voltage characteristics

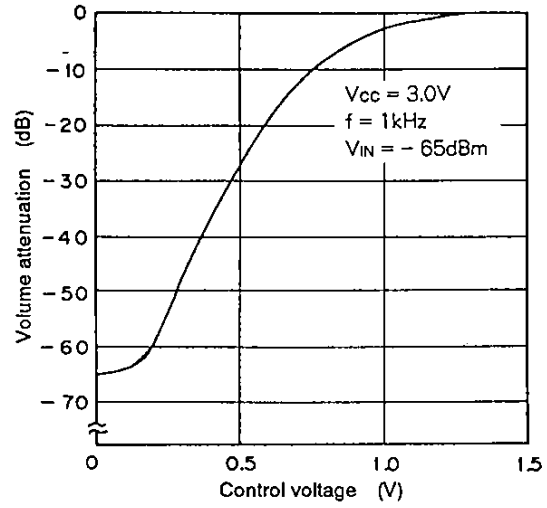

Gain vs. Vcc characteristics (VIN=-75dBm, f=1kHz)

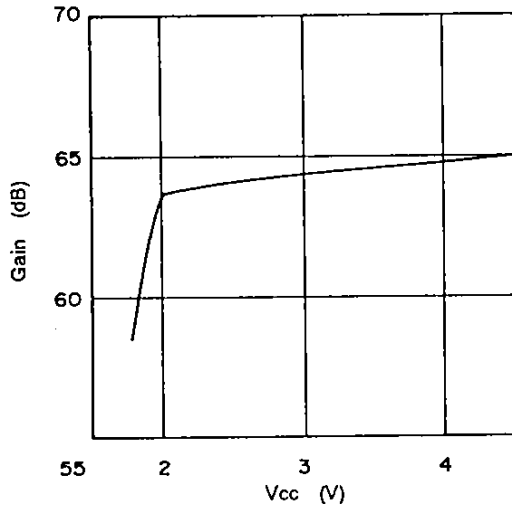

Distortion factor vs. Input characteristics (Vcc=3V, f=1kHz)

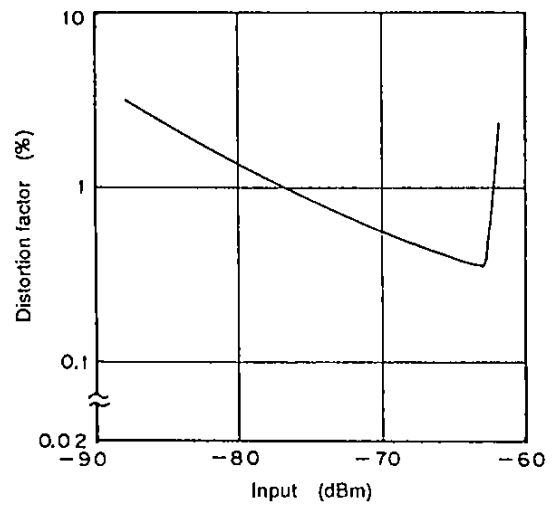

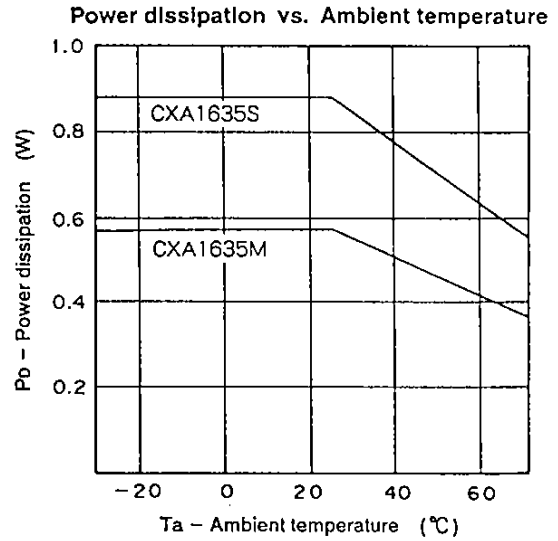
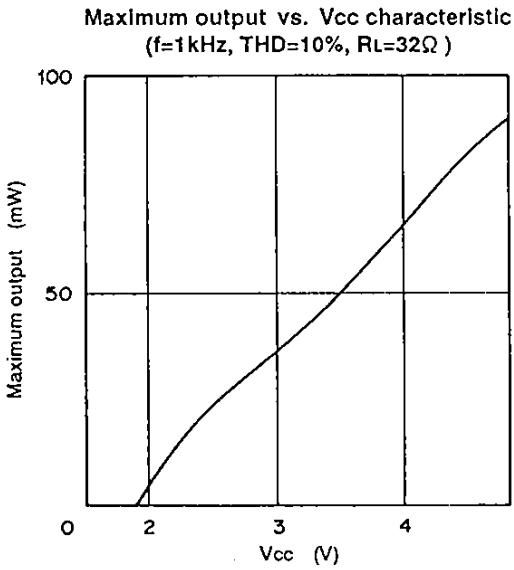
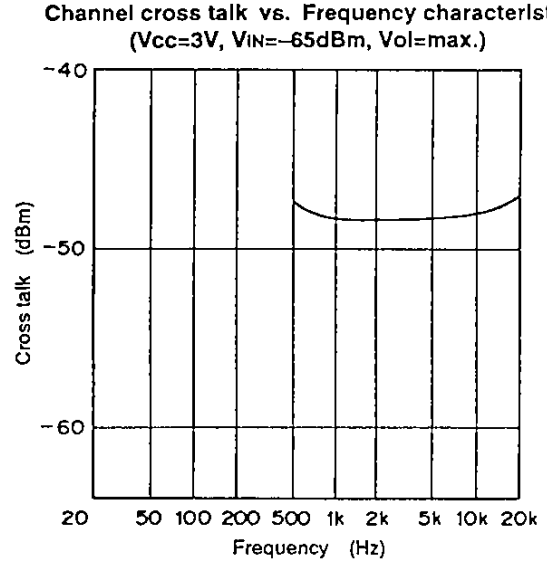
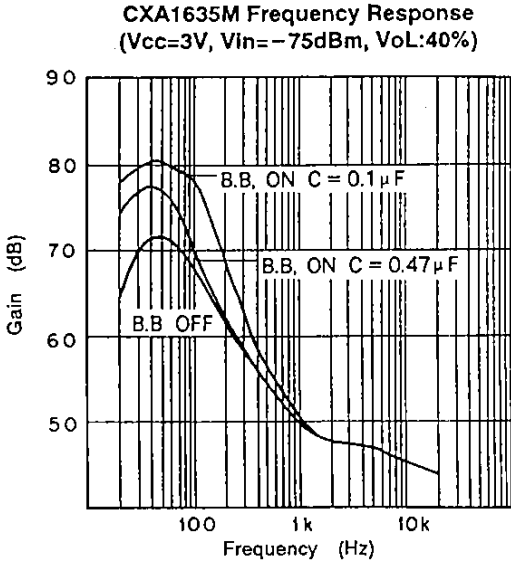

Package Outline Unit : mm

CXA1635S 22pin SDIP (Plastic) 300mil

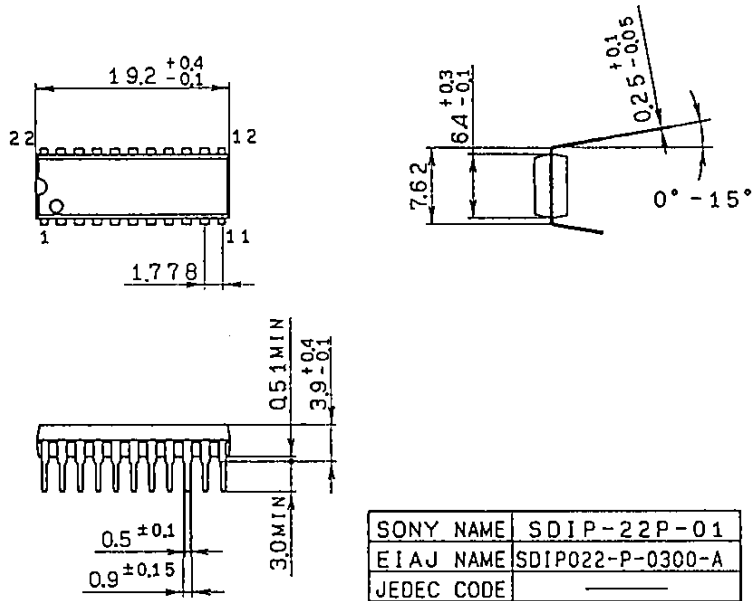

CXA1635M 24pin SOP (Plastic) 300mil 0.3g

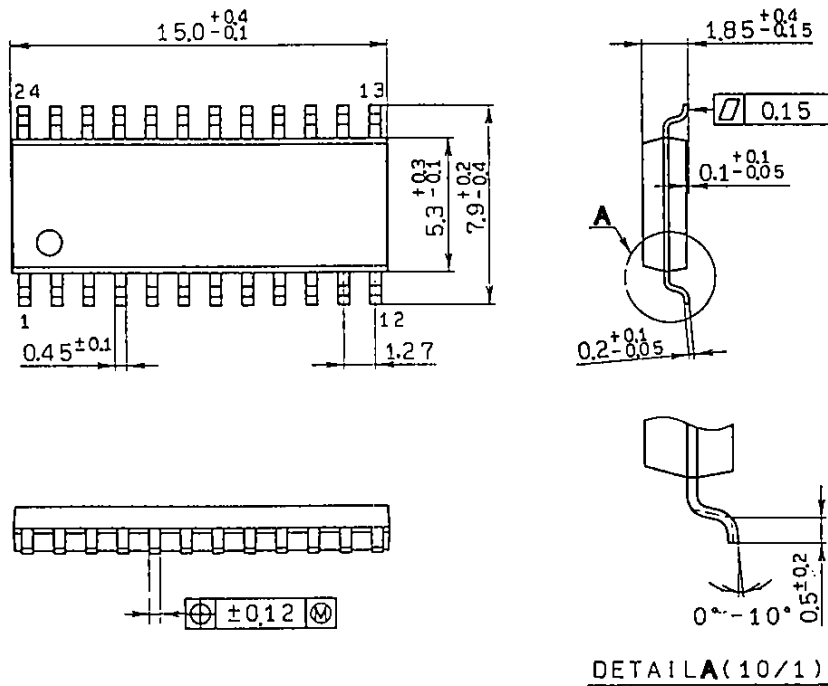

SONY NAME	SOP-24P-L01
EIAJ NAME	*SOP024-P-0300-A
JEDEC CODE	