

# AN5352N

## Character and Pattern Interface IC

### Overview

The AN5352N is an integrated circuit designed for interface between the color output stage and the teletext system decoder output, or external analog input signal.

### Features

- The AN5352N provides analog signal processing for character signal input
- High speed switching  
Rise and Fall time...35ns, Delay time...20ns
- Including DC controller of Brightness, Contrast, R-adjustment and B-adjustment for character signal input
- Y amplifier linear area's bottom...2.0V

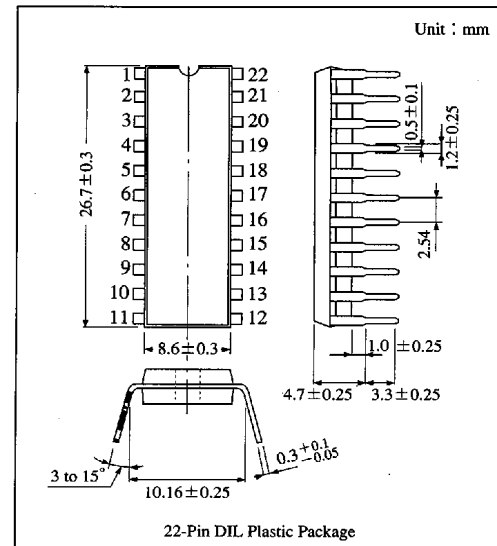

### Block Diagram

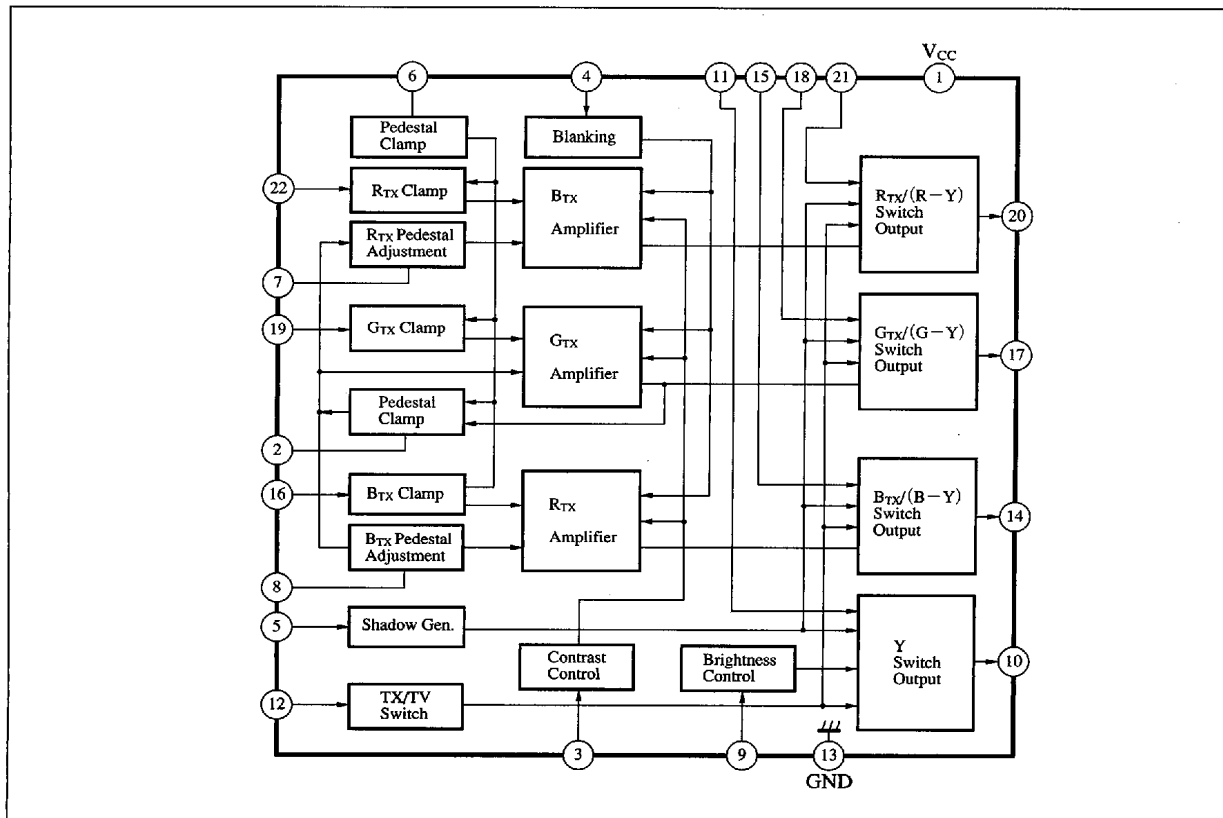

6932852 0014285 OTT

Panasonic

### ■ Absolute Maximum Ratings (Ta=25°C)

| Parameter                   |                            | Symbol                      | Rating                   |                          | Unit |
|-----------------------------|----------------------------|-----------------------------|--------------------------|--------------------------|------|
| Voltage                     | Supply voltage             | V <sub>CC</sub>             | 14.4                     |                          | V    |
|                             | Circuit voltage            | V <sub>1-13</sub>           | 0                        | 14.4                     | V    |
|                             |                            | V <sub>3, 6, 8, 9-13</sub>  | 0                        | V <sub>1-13</sub>        | V    |
|                             |                            | V <sub>11-13</sub>          | 2                        | (V <sub>1-13</sub> ) - 1 | V    |
|                             | V <sub>15, 18, 21-13</sub> | 0                           | (V <sub>1-13</sub> ) - 1 | V                        |      |
| Current                     | Circuit current            | I <sub>10, 14, 17, 20</sub> | -30                      | 10                       | mA   |
|                             |                            | I <sub>16, 19, 22</sub>     | -1                       | 3                        | mA   |
| Power dissipation (Ta=70°C) |                            | P <sub>D</sub>              | 1040                     |                          | mW   |
| Temperature                 | Ambient temperature        | T <sub>opr</sub>            | -20 to +70               |                          | °C   |
|                             | Storage temperature        | T <sub>sig</sub>            | -55 to +150              |                          | °C   |

### ■ Electrical Characteristics (V<sub>CC</sub>=12V, Ta=25°C)

| Parameter  | Symbol                                  | Condition  | min  | typ  | max  | Unit             |
|--|---|--|------|------|------|------------------|
| Total circuit current  | I <sub>tot</sub>                        | V <sub>CC</sub> =12V   | 32   | 47   | 62   | mA               |
| Circuit voltage  | V <sub>10,14,17,20-13</sub>             | V <sub>CC</sub> =12V   | 7.7  | 8.0  | 8.3  | V                |
|  | V <sub>16,19,22-13</sub>                |  | 3.0  | 3.5  | 4.0  | V                |
| TV signal voltage amplification  | A <sub>V1</sub>                         | f=500kHz, Sine wave signal 1 V <sub>P-P</sub>  | 0.95 | 0.98 | 1.00 | times            |
| AV <sub>1</sub> relative voltage amplification                                 | ΔA <sub>V1</sub>                        | f=500kHz, Sine wave signal 1 V <sub>P-P</sub>  | 0.95 | 1.00 | 1.05 | times            |
| TV signal frequency characteristics  | f <sub>V</sub>                          | Sine wave signal 1 V <sub>P-P</sub> , Frequency in which A <sub>V1</sub> becomes -3dB                      | 20   | —    | —    | MHz              |
| Character signal voltage amplifications  | A <sub>V2</sub>                         | Character input 1 V <sub>P-P</sub> , Contrast max.   | 3.0  | 3.4  | 3.8  | times            |
| AV <sub>2</sub> relative voltage amplifications                                | ΔA <sub>V2</sub>                        | Character input 1 V <sub>P-P</sub> , Relative output voltage   | 0.85 | 1.00 | 1.15 | times            |
| Character signal contrast ratio  | Δe <sub>0</sub>                         | Contrast max./min.   | 3.0  | 3.5  | 4.0  | times            |
| Character signal rise/fall time  | t <sub>r(TX)</sub> , t <sub>f(TX)</sub> | V <sub>3</sub> =V <sub>9</sub> =6V   | —    | 35   | 60   | ns               |
| Character signal rise delay time   | t <sub>d-r(TX)</sub>                    | V <sub>3</sub> =V <sub>9</sub> =6V   | —    | 25   | 60   | ns               |
| Character signal fall delay time   | t <sub>d-f(TX)</sub>                    | V <sub>3</sub> =V <sub>9</sub> =6V   | —    | 30   | 60   | ns               |
| Character signal t <sub>dr</sub> , t <sub>df</sub> 3-channel mutual difference | Δt <sub>d(TX)</sub>                     | V <sub>3</sub> =V <sub>9</sub> =6V   | —    | —    | 20   | ns               |
| TX-TV changeover rise delay time   | t <sub>d-r(TX/TV)</sub>                 | V <sub>3</sub> =V <sub>9</sub> =6V   | —    | 60   | 80   | ns               |
| TX-TV changeover fall delay time   | t <sub>d-f(TX/TV)</sub>                 | V <sub>3</sub> =V <sub>9</sub> =6V   | —    | 50   | 70   | ns               |
| TX-TV changeover t <sub>dr</sub> , t <sub>df</sub> mutual difference           | Δt <sub>d(TX/TV)</sub>                  | V <sub>3</sub> =V <sub>9</sub> =6V   | —    | —    | 20   | ns               |
| TX-TV discrimination level   | V <sub>i(TX/TV)</sub>                   |  | 0.50 | 0.65 | 0.70 | V                |
| Crosstalk between TV signal channels   | CT <sub>TV</sub>                        |  | 40   | 45   | —    | dB               |
| Crosstalk between TV signal channels   | CT <sub>TX</sub>                        |  | 40   | 45   | —    | dB               |
| TV-to-character changeover crosstalk   | CT <sub>TX/TV</sub>                     |  | 40   | 45   | —    | dB               |
| Pedestal deviation by character signal contrast change                         | ΔE <sub>TP-C</sub>                      | Brightness typ., Contrast min. to max.   | —    | 0    | ±150 | mV               |
| TV signal input DC level standard  | TV <sub>1</sub>                         | TV input signal level [(R-Y) <sub>TV</sub> , (G-Y) <sub>TV</sub> , (B-Y) <sub>TV</sub> , Y <sub>TV</sub> ] | 2.0  | —    | 10.5 | V                |
| Character signal input level standard  | TX <sub>1</sub>                         | Character input signal level [R <sub>TX</sub> , G <sub>TX</sub> , B <sub>TX</sub> ]                        | —    | 1.0  | 1.2  | V <sub>P-P</sub> |
| TX-TV signal input level standard  | TX/TV <sub>1</sub>                      |  | 0    | —    | 6.0  | V                |



■ 6932852 0014286 T36 ■

Panasonic

**Input/Output Pulse Waveform**

- The rise/fall time of P.G ① to ⑤ should not exceed 5ns.
- Rise/fall time is enlarged in the period corresponding to P.G ① and P.G ⑤ output waveforms.

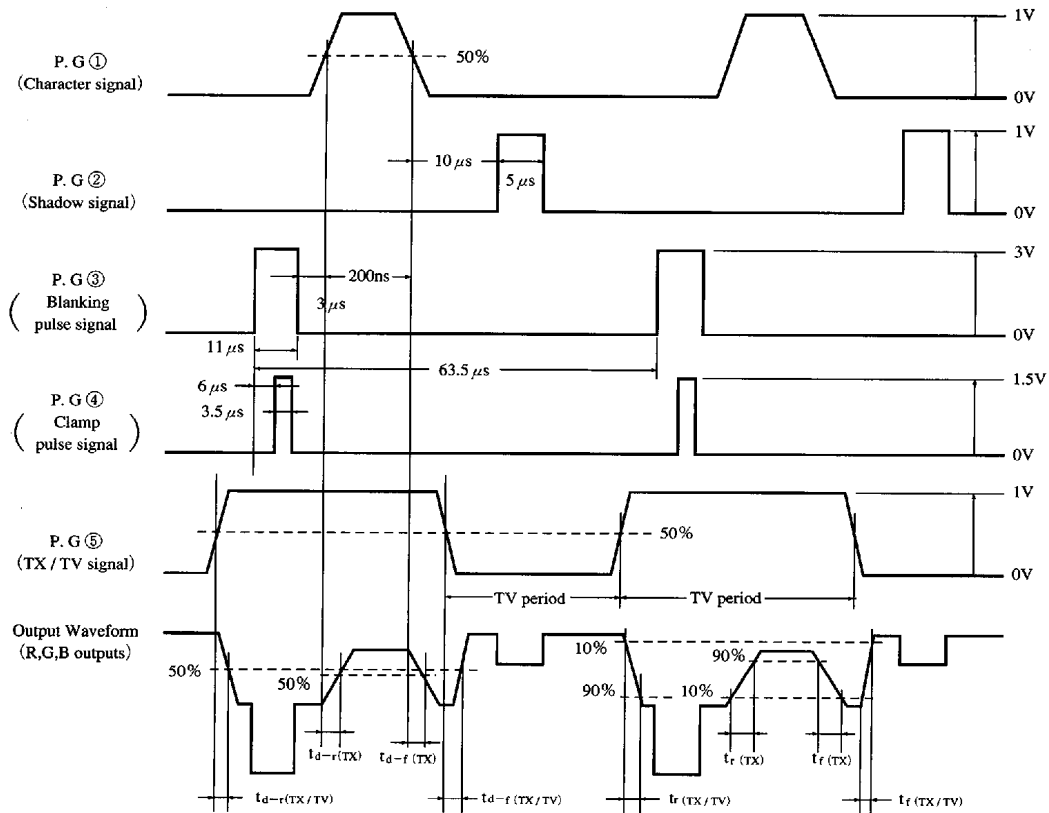

**Application Circuit**

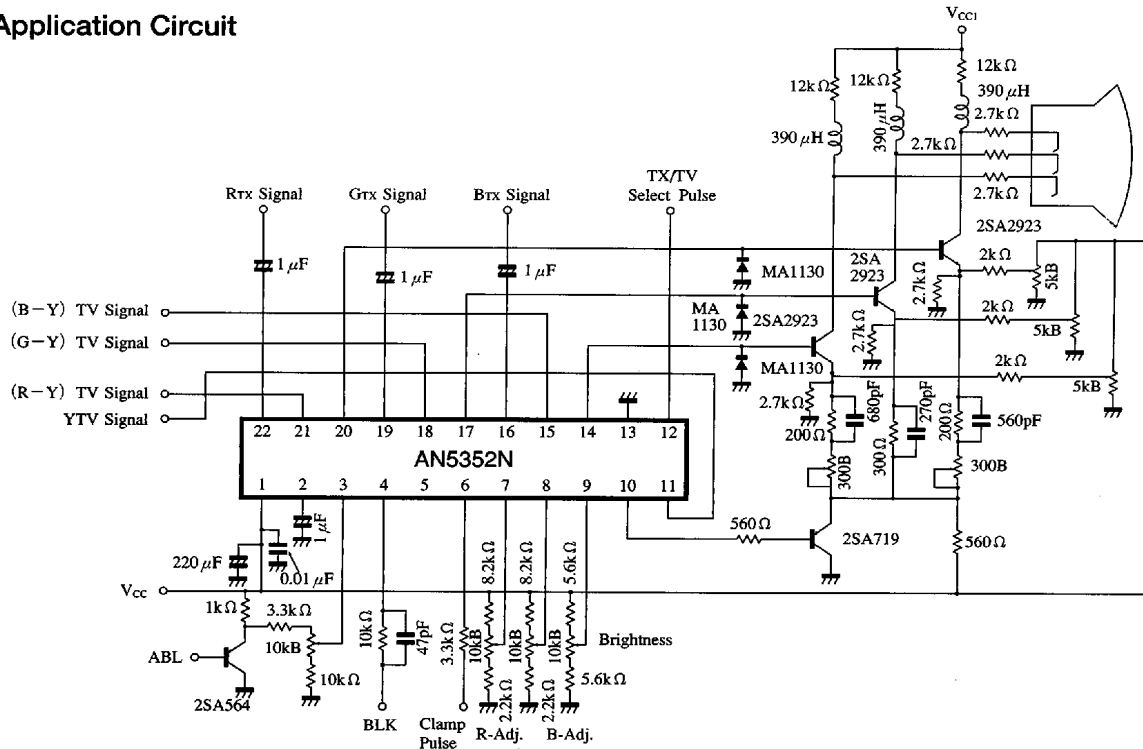

6932852 0014287 972

Panasonic