

SIGNAL PATH PRODUCTS

Real Time Clocks
Switches/Multiplexers
Interface
Digital Potentiometers
Data Converters
High Speed Op Amps
Precision Op Amps
Precision Instrumentation Amplifiers
Precision Voltage References
Power Management

intersil[™]



SIMPLY SMARTER[™]

Intersil Signal Path Products

Providing high-performance solutions for every link in the signal chain.

Intersil Signal Path Products are creating a state of the art product portfolio built on the latest technology. We offer a wide portfolio of general purpose analog building blocks targeted at precision signal chain design.

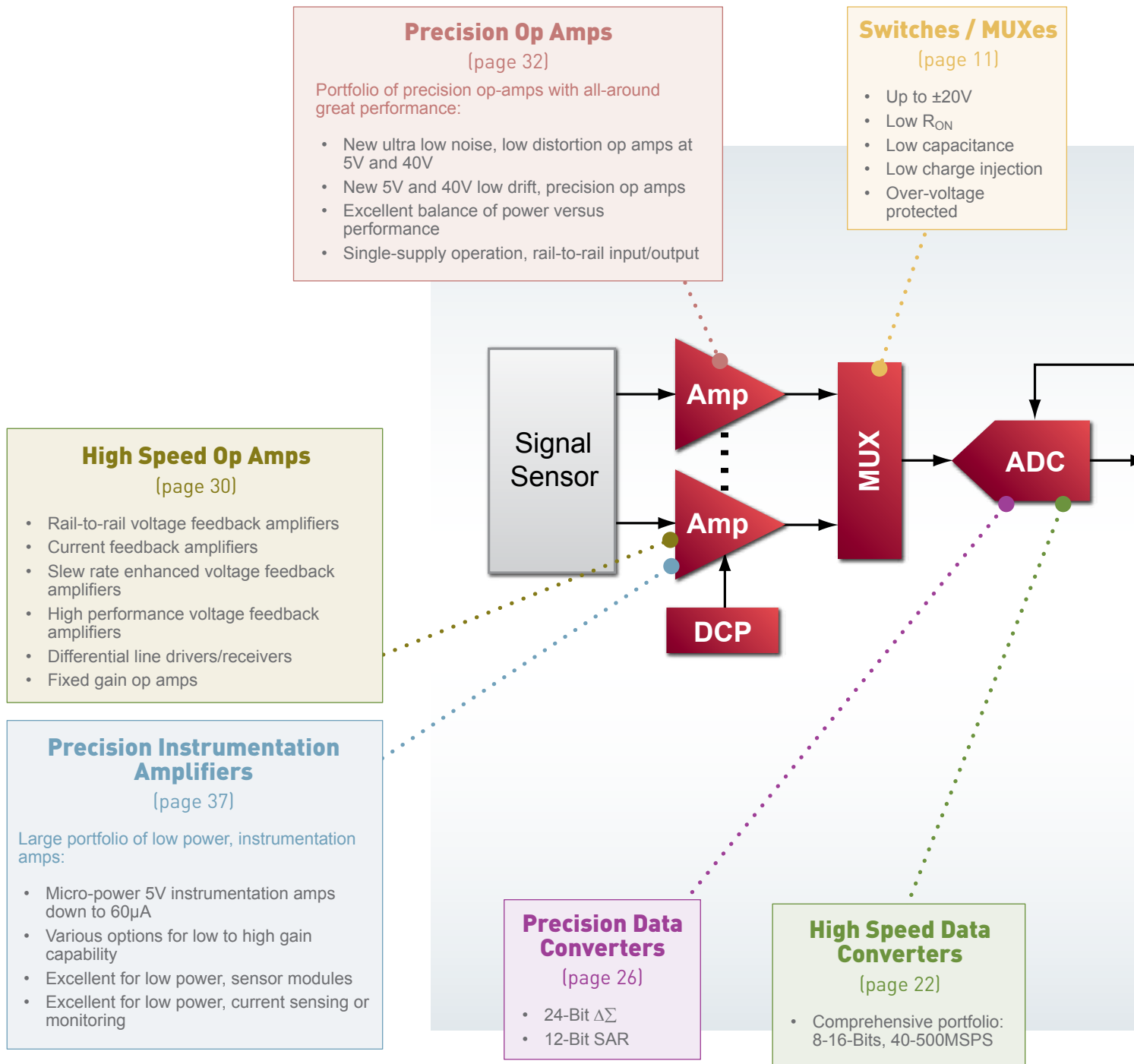



Process Control (page 4)



Weigh Scale (page 5)



Data Acquisition System (page 6)



Patient Monitors (page 7)

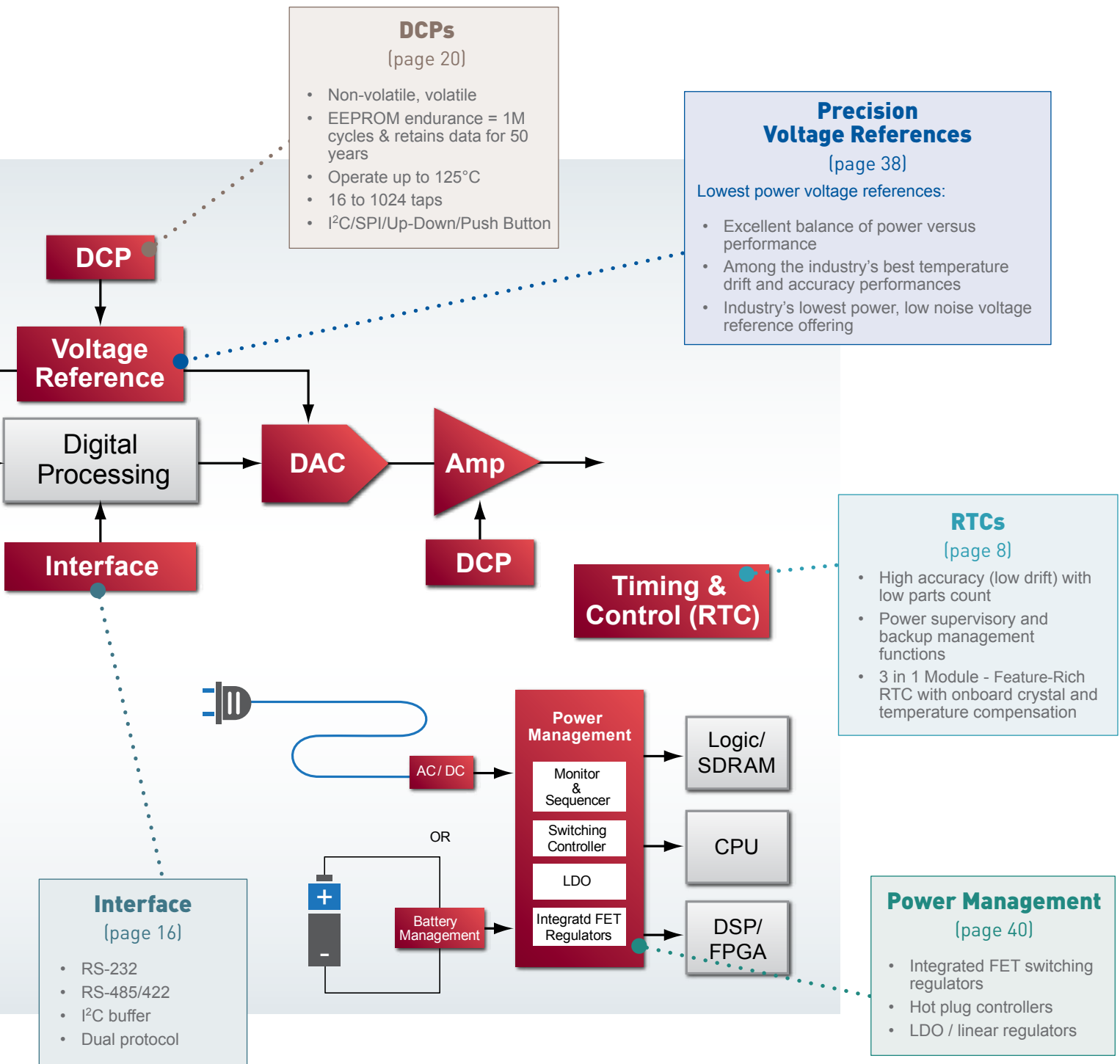

Intersil's Solutions For Process Control

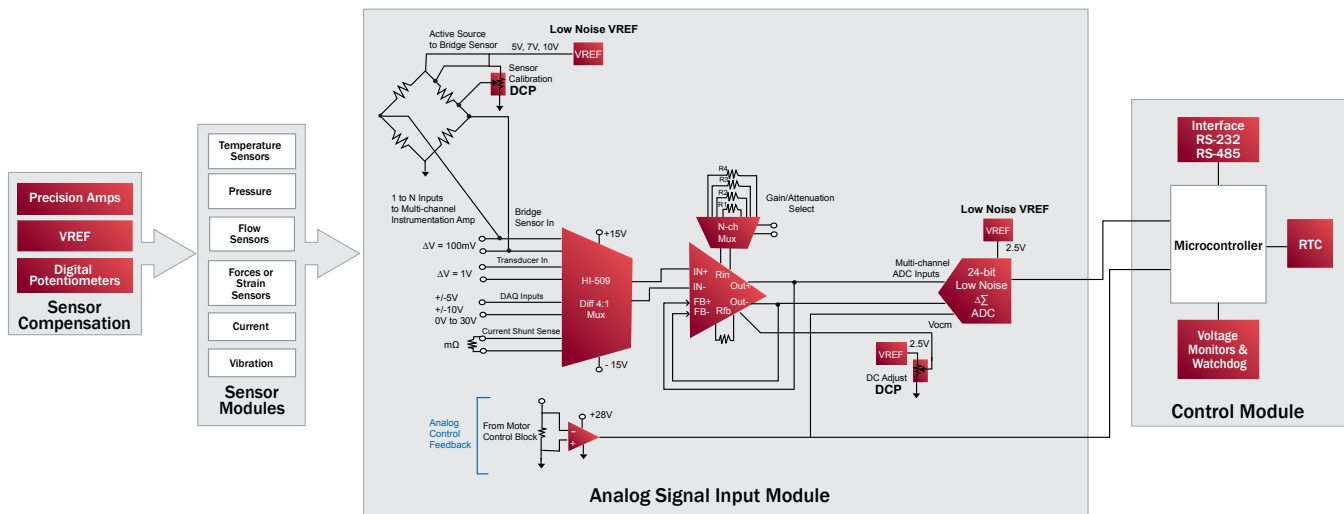

Key Products

Product Type	Part Number	Where Used in Process Control	Key Features / Benefits
Precision Amplifiers	40V ISL28127/227, ISL28117/217/417, ISL28107/207/407, ISL28108/208/408, ISL28118/218, ISL28110/210	<ul style="list-style-type: none"> In analog input modules to signal condition incoming signals In analog output modules for driving signals to the outside world 	<ul style="list-style-type: none"> Wide operating voltage range Single or dual supply Low offset & drift
	Low Drift 5V ISL28134, ISL28133/233/433, ISL28148/248, ISL28136/236, EL8176		
Digital Potentiometers	Dual Supply Non-volatile 256-tap ISL223x3 (I ² C), ISL224x4 (SPI)	<ul style="list-style-type: none"> Sensor compensation 	<ul style="list-style-type: none"> Non-volatile settings Digitally settable resistance or voltage 1st DCP with memory to operate up to 125°C Ideal for Industrial applications
	Single Supply Non-volatile 128-tap ISL223x6 (I ² C), ISL224x6 (SPI)		
Instrumentation Amplifiers	Low Power, Integrated Solution EL8172/73		
	40V Precision, Low Noise In-Amp, Integrated Solution ISL28617	<ul style="list-style-type: none"> Sensor front ends 	<ul style="list-style-type: none"> Low noise Low power High CMRR Low drift
	Ultra Low Power 5V, Customize (Roll Your Own) ISL28194		
	Low Cost 5V Customize (Roll Your Own) ISL28230		
Voltage References	Low Noise ISL21009, ISL21090, ISL21400	<ul style="list-style-type: none"> Used as active sources for sensors 	<ul style="list-style-type: none"> Low tempco Low drift Low power
	Low Cost ISL21070, ISL21080, ISL60002, ISL21010	<ul style="list-style-type: none"> Accurate voltage sources for data conversion 	
Switches / MUXes	HI-509A, HI-546, DG408, DG409	<ul style="list-style-type: none"> Direct sensor interface In front of actuator buffer amps 	<ul style="list-style-type: none"> Over-voltage protected Latch-up free Low leakage
Interface	RS-232 ISL4221E, ISL3232E, ISL4243E RS-485 ISL317xE, ISL315xE, ISL3249xE	<ul style="list-style-type: none"> System and control 	<ul style="list-style-type: none"> High ESD protection Small packages Over voltage protected
RTCs	ISL12024, ISL12025, ISL12026	<ul style="list-style-type: none"> Standalone controllers Remote monitors Data recorders System monitors 	<ul style="list-style-type: none"> System power supervision with watchdog and power-on reset Onboard 512-bit EEPROM storage 64-bit Factory-programmed Unique ID IRQ, frequency outputs
Analog-Digital Converters	24-bit Delta-Sigma ADCs ISL26132, ISL26134	<ul style="list-style-type: none"> Low-cost load, pressure/temperature sensing 	<ul style="list-style-type: none"> Lowest noise/high accuracy at low cost Complete solution Easy to use
	ISL26102, ISL26104	<ul style="list-style-type: none"> Precision weigh scales, dynamic weighing, pressure sensing, safety monitors 	<ul style="list-style-type: none"> Industry-leading low noise up to 4000SPS Integrated PGA ensures measurement accuracy Cost-effective high-performance solution
	10, 12-bit SAR ADCs ISL263xx Multichannel Family 125kSPS, 250kSPS	<ul style="list-style-type: none"> Temperature pressure, flow/vibration sensors Multichannel modules and systems 	<ul style="list-style-type: none"> Cost-effective multiple-channel monitoring Buffered inputs reduce board space, solution cost Low power, low cost

Intersil's Solutions For Weigh Scale

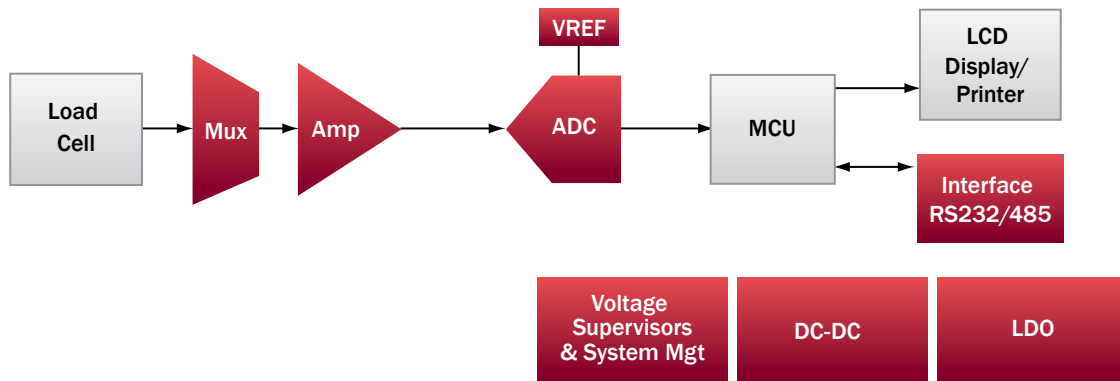

Key Products

Product Type	Part Number	Where Used in Weigh Scale	Key Features / Benefits
Precision Amplifier	Low Noise 5V ISL28190, ISL28191	Strain gauge sense amps	<ul style="list-style-type: none"> · Low offset · Low drift · High CMRR / PSRR
	40V ISL28117/217/417, ISL28118/218		
	Low Drift, Precision, 5V ISL28133, EL8176, ISL28134, ISL28133/233/433, ISL28136/236	Voltage reference buffer circuits	
Instrumentation Amplifiers	Low Cost Op Amps ISL28113/213/413 ISL28114/214/414 ISL28130/230/430	Strain gauge sense amp	<ul style="list-style-type: none"> · Low power
	Low Power In-Amps 5V EL8170, EL8172/72, ISL28274	Bridge front ends	<ul style="list-style-type: none"> · Low power
40V Precision, Low Noise In-Amp ISL28617			
Voltage References	Low Noise References ISL21009, ISL21090	Used as active sources for sensors	<ul style="list-style-type: none"> · Low noise · Low power
	Low Cost References ISL21070, ISL21080, ISL60002	Accurate voltage sources for data conversion	
Interface	RS-232 ISL4221E, ISL3232E	Serial communication between the system slave and master	<ul style="list-style-type: none"> · IEC61000 ESD · Small packages · Enhanced V_{OD} (ISL315XE)
	RS-485 ISL317XE, ISL315XE		
Switches/ MUXes	ISL43741 ISL84052 ISL84582	Sensor signal multiplexing between load cell and signal conditioning amplifier, allows very accurate ADC to be shared between load cells	<ul style="list-style-type: none"> · Low R_{ON} for low signal loss and higher accuracy · Usually differential connections to keep noise low · Small size
Analog-Digital Converters	24-bit Delta-Sigma ADCs ISL26132, ISL26134	Low-cost counter/trade/commercial/retail scales	<ul style="list-style-type: none"> · Lowest noise/high accuracy at low cost · Complete solution · Easy to use
	ISL26102, ISL26104	Precision scales, counting scales, trade scales, dynamic weighing, pressure sensing, safety monitors	<ul style="list-style-type: none"> · Industry-leading low noise up to 4000SPS · Integrated PGA ensures measurement accuracy · Cost-effective high-performance solution

Intersil's Solutions For Data Acquisition System

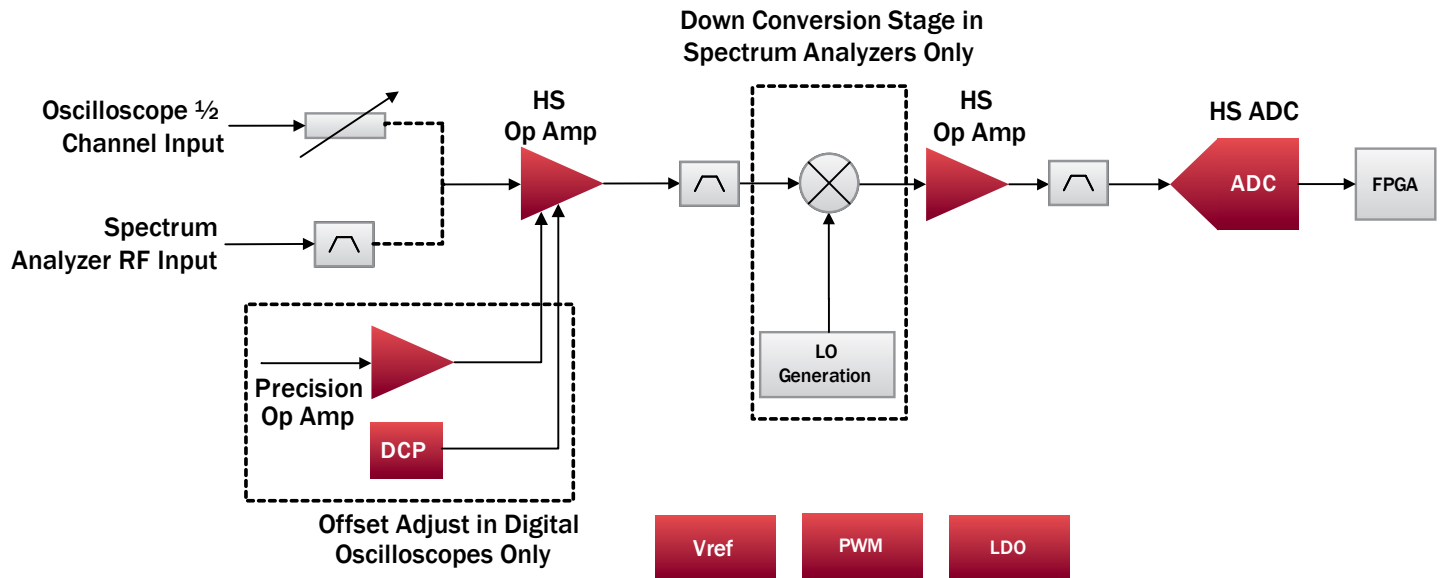

Key Products

Product Type	Part Number	Target Applications	Differentiator
Lowest Power, High Performance HS ADCs	12 Bit 500MSPS HS ADC ISLA112P50, KAD5512P-50	<ul style="list-style-type: none"> High speed data acquisition Spectrum analyzers Communication analyzers Digital oscilloscopes 	<ul style="list-style-type: none"> Much lower power enables compact design Enables portable designs (battery operation) Highest dynamic range improves measurement accuracy
High Linearity, Low Power DACs	14-Bit 270MSPS HS DAC ISL5957	<ul style="list-style-type: none"> Arbitrary waveform generator (AWG) RF signal generators Automatic test equipment (ATE) 	<ul style="list-style-type: none"> Excellent SFDR eases filtering requirements Low power eases thermal design Dual available for multi-channel applications
Fastest and Lowest Power HS Op Amps	1.4GHz Current Feedback Amplifier (AC-coupled) EL5166 500MHz Rail-to-Rail Op Amp (DC-coupled) EL8102	<ul style="list-style-type: none"> Same applications as those of HS ADCs and DACs 	<ul style="list-style-type: none"> Best-in-class speed, linearity, and power for driving/ buffering HS ADCs/DACs in data acquisition systems
DCPs	ISL95811, ISL22316 (I ² C), ISL22416 (SPI)	<ul style="list-style-type: none"> Adjusts the offset of the high speed op amp in data acquisition products 	<ul style="list-style-type: none"> World's largest offering of nonvolatile DCPs "Set and Forget" with EEPROM in DCPs
Precision Op Amps	ISL28110/210, ISL28127/227, ISL28136/236, ISL28118/218, ISL28134, ISL28117/217/417	<ul style="list-style-type: none"> Data acquisition DSO 	<ul style="list-style-type: none"> Low noise, high voltage, rail-to-rail output, high input impedance, robust inputs
Voltage References	Low Noise References ISL21009, ISL21090 Low Cost References ISL21070, ISL21080, ISL60002, ISL21010	<ul style="list-style-type: none"> Used as active sources for sensors Accurate voltage sources for data conversion 	<ul style="list-style-type: none"> Low noise Low power
Instrumentation Amp	Low Noise, High Voltage, Rail-to-Rail Output, Integrated ADC Driver ISL28617	<ul style="list-style-type: none"> Data acquisition 	<ul style="list-style-type: none"> Low noise High voltage Rail-to-rail output Integrated ADC driver

Intersil's Solutions For Patient Monitors

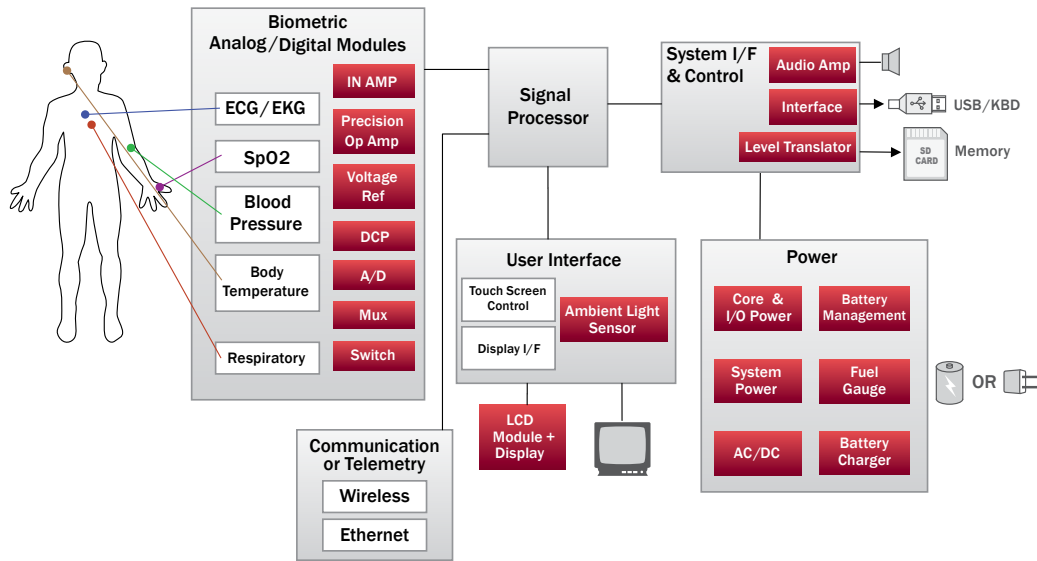

Key Products

Product Type	Part Number	Target Applications/Where used	Key Features / Benefits
Precision Amplifiers	Low Noise (0.1 to 10Hz) ISL28127/227, ISL28134, ISL28117/217/417, ISL28118/218, ISL28107/207/407, ISL28136/236, ISL28110/210, ISL28133/233/433, EL8176	ECG, EEG Imaging Body probe front-ends, RF rectification, secondary stage, gain/filtering, right leg drive. Required for accuracy of signal conditioning. Blood Pressure and Body Temperature Low noise gain frontends for thermocouple. Precision amps required for accuracy of signal conditioning.	<ul style="list-style-type: none"> High impedance inputs Low noise (0.1 to 10Hz) Low noise gain amplification Low offset and low drift
	Low Cost Op Amps ISL28113/213/413 ISL28114/214/414 ISL28130/230/430	Pulse Oximeters Transimpedance front end. High impedance, charge amps Respiratory/anesthesia Sensor front end, high impedance, low noise, low drift	
	Low Power In-Amps EL8172/72, ISL28273	ECG, EEG Imaging Portable, 5V body potential probe gain amp Blood Pressure and Body Temperature Sensor amp front end	<ul style="list-style-type: none"> High CMRR Low offset drift Multiple channel In-Amps
Digital Potentiometers (DCPs)	Precision DCP ISL22317	End-user Adjustment Controlling display contrast or backlight, drip rate, dosage, etc	<ul style="list-style-type: none"> 1st low voltage 1% accurate DCP to reduce additional calibration
	Low Voltage, Volatile DCPs ISL233x5/ISL234x5	Sensor Front ends (Blood Pressure, Pulse Oximeters, Respiratory/anesthesia, ECG) Compensate and gain small signal from the sensor.	<ul style="list-style-type: none"> Industry's lowest operating voltage DCP
Interface	RS-232 ISL4221E, ISL3232E, ISL4243E RS-485 ISL317xE, ISL315xE, ISL3249xE	System and Control Serial communication port	<ul style="list-style-type: none"> High ESD protection Small packages Over voltage protected
Voltage Level Translators	ISL303xE	SD Memory Card & Other Applications Used to interface mixed voltage devices VL as low as 1.5V up to 3.3V VCC	<ul style="list-style-type: none"> Highest ESD protection Small leadless packages
Switches/ MUXes	ISL43640, ISL43681, HI-509A, HI-546, DG408, DG409	Front-end multiplexing	<ul style="list-style-type: none"> Low power Small size Low leakage
Voltage Reference	High Precision: ISL21009, ISL21090, ISL60002, X60003, ISL21060	Reference for converters, micro-controllers	<ul style="list-style-type: none"> Low noise, low drift, low long term drift, low power
	Low Cost: ISL21070, ISL21080, ISL21010		
Analog-Digital Converters	24-bit Delta-Sigma ADCs ISL26132, ISL26134	Temperature Sensing Body/Fluid Temperature	<ul style="list-style-type: none"> Low noise/high accuracy Low cost Complete solution
	ISL26102, ISL26104	Diagnostic ECG Precision wide-bandwidth ECG	<ul style="list-style-type: none"> Low noise up to 4000SPS Integrated PGA ensures measurement accuracy Complete cost-effective solution
	10, 12-bit SAR ADCs ISL263xx Multichannel Family 125kSPS, 250kSPS	Blood Pressure, Fluid Flow Sensing	<ul style="list-style-type: none"> Cost-effective multiple-channel monitoring Buffered inputs reduce board space, solution cost Low power, low cost
	ISL267xx Low-Cost Family 20kSPS to 1MSPS	Blood Pressure, Fluid Pressure, Fluid Flow Sensing Compact Packages for Remote Sensors	<ul style="list-style-type: none"> High accuracy, low-distortion measurement Low power, low cost Compact packages including 3x3mm TDFN

Real Time Clocks

Intersil's family of Real Time Clock products offer a wide variety of useful industry-standard functions and features including clocks and calendars, programmable alarms with event recording, non-volatile memory for system personality data and unique device IDs, and power supervision including backup battery and system shutdown management. The 3-in-1 Module products feature an integrated 32kHz crystal with onboard temperature sensor, to maintain high accuracy over the rated temperature range without user calibration.

Target Applications

- Handheld / Portable Devices
- Industrial / Communications / Specialty
- High Volume Consumer
- Residential / Industrial Power Meter

High-Accuracy RTC Modules

3 in 1 RTC Module (RTC + Embedded Crystal + Temp Sensor) Achieves Better than +5ppm Accuracy

Key Features

- **±5ppm Accuracy (-40°C to +85°C)**
 - Factory programmed RTC for optimal accuracy
 - Onboard temperature sensor
 - Embedded crystal
- **Reliable Timekeeping & Power Management**
 - Backup battery management
 - V_{DD} and battery status monitors and switchover timestamp
 - Battery ReSeal™ function extends battery shelf life
- **User Programmability**
 - I²C Interface
 - 128 bytes battery-backed user SRAM
- **See also**
 - ISL12020M (DFN 3 in 1); ISL12022 and ISL12023 standalone RTCs

RTC Modules with Embedded Crystal and Temp Comp: ISL12022M

Block Diagram

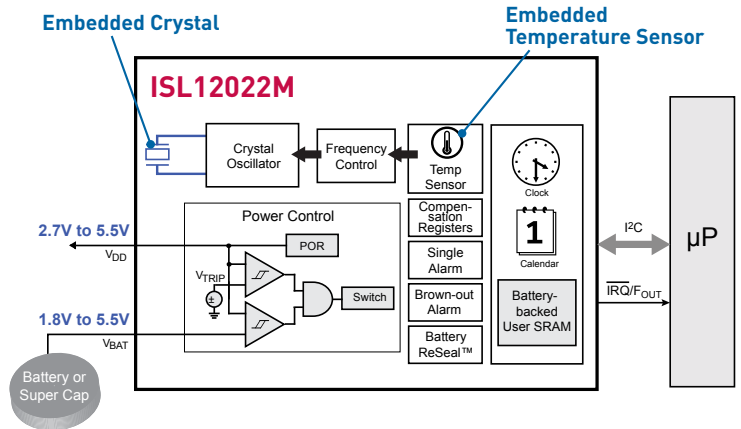

High Accuracy Even in Extreme Temperature Conditions

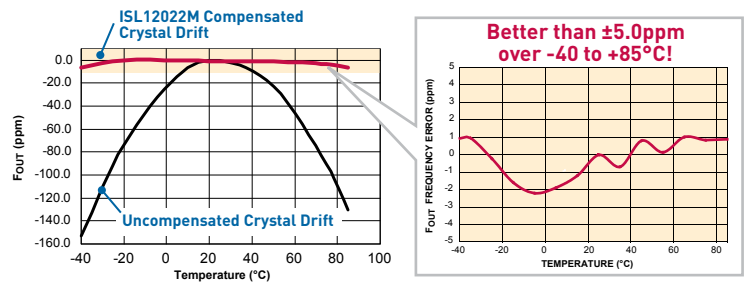

Device	I _{BAT} (nA)	Alarms	Selectable Frequency Output	CPU Supervisory Function		Battery		IRQ	F _{OUT}	SRAM	Other Functions	Package
				POR	Watch-dog Timer	Seal	Backup					
ISL12020M	1000	1	15	N	N	Y	Y	Shared Pin	128 Bytes	• Battery Switchover Time Stamp • Battery Status Monitor	20 Ld DFN	
ISL12022M	1000	1	15	N	N	Y	Y	Shared Pin	128 Bytes	• Battery Switchover Time Stamp • Battery Status Monitor	20 Ld SOIC	
ISL12022MA	1000	1	15	N	N	Y	Y	Shared Pin	128 Bytes	• Enhanced Environmental Moisture Tolerance • 100% Pin Compatible with ISL12022M • Firmware Compatible with ISL12020M and ISL12022M	Enhanced 20 Ld SOIC	
ISL12022M-R5421	1000	1	15	N	N	Y	Y	Shared Pin	128 Bytes	• Enhanced ESD Performance • 100% Pin Compatible with ISL12022M • Firmware Compatible with ISL12020M and ISL12022M	Enhanced 20 Ld SOIC	

Low Power RTC with Battery Backed SRAM and 50/60 Cycle AC Input and Xtal Back-up

Feature-Rich RTC with 50/60 Cycle AC Input

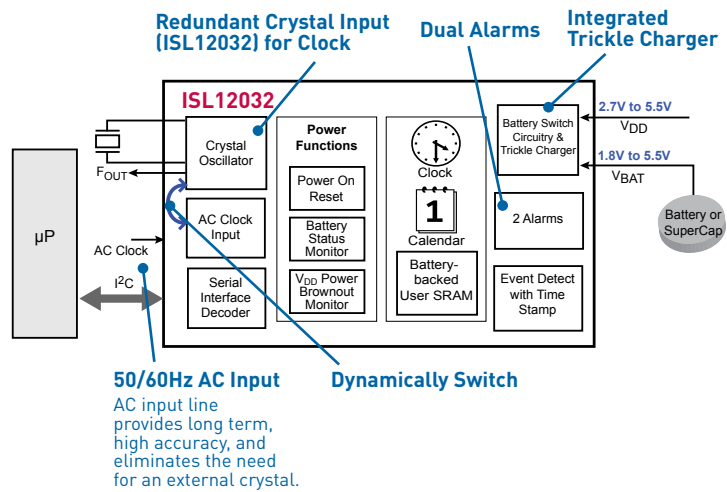

Key Features

- **Longer Super Capacitor Life**
 - Integrated trickle charger
 - Four selectable charging rates
- **Power Failure Safety Feature**
 - Dynamically switch from AC clock input to crystal
- **Security and Event Functions**
 - Stores first and last three event time stamps
- **User Programmability**
 - I²C interface
 - 128 bytes battery- backed user SRAM
- **See Also**
 - ISL12030 (Industry-Standard 8-lead SOIC package)

Device	I _{BAT} (nA)	Alarms	Selectable Frequency Output	CPU Supervisory Function		Battery		IRQ	F _{OUT}	SRAM	Other Functions	Package
				POR	Watch-dog Timer	Seal	Backup					
With 50/60 Cycle AC Input												
ISL12030	N/A	2	N	N	N	N	N	Y	N	128 Bytes	• AC Input	8 Ld SOIC
ISL12032	800	2	7	Y	Y	N	Y	Y	Y	128 Bytes	• AC Input • Crystal Backup • Trickle Charger	14 Ld TSSOP
High Precision RTC with On-Chip Temperature Sensor												
ISL12022	1000	1	15	N	N	Y	Y	Shared Pin		128 Bytes	• Battery Switchover Time Stamp • Battery Status Monitor	8 Ld SOIC
ISL12023	1000	1	15	N	N	Y	Y	Dedicated Pin	Dedicated Pin	128 Bytes	• Battery Switchover Time Stamp • Battery Status Monitor	14 Ld TSSOP
With Embedded Unique ID												
ISL12024	850	2	3	N	N	Y	Y	Shared Pin		512x8-Bit EEPROM	• 64-bit Unique ID	8 Ld SOIC, 8 Ld TSSOP
ISL12024IRTCZ	850	2	3	N	N	Y	Y	Shared Pin		512x8-Bit EEPROM	• 64-bit Unique ID	8 Ld TDFN
ISL12025	850	2		Y	Y	Y	Y	-	-	512x8-Bit EEPROM	• 64-bit Unique ID • CPU Supervisor	8 Ld SOIC, 8 Ld TSSOP
With Integrated EEPROM and CPU Supervisory Functions												
ISL12026	850	2	3	N	N	Y	Y	Shared Pin		512x8-Bit EEPROM		8 Ld SOIC, 8 Ld TSSOP
ISL12026A	850	2	3	N	N	Y	Y	Shared Pin		512x8-Bit EEPROM		8 Ld SOIC, 8 Ld TSSOP
ISL12027	850	2		Y	Y	Y	Y	-	-	512x8-Bit EEPROM		8 Ld SOIC, 8 Ld TSSOP
ISL12028	850	2	3	Y	Y	Y	Y	Shared Pin		512x8-Bit EEPROM		14 Ld SOIC, 14 Ld TSSOP
ISL12029												

World's Smallest, Low Cost and Low Power RTC

Key Features

- **Low Power**
 - Time keeping current = 650nA max @ 1.8V
- **Ideal for Portable Applications**
 - Operates over 1.4V to 3.6V supplies
- **56% Smaller than Competitive Solutions**
 - 8- μ TDFN (2x2x0.55mm)
- **Easy to Design-in**
 - Pin-to-pin replacement: 8-tDFN (3x3mm), 8-MSOP, 8-SOIC
- **User Programmability**
 - I²C interface
 - Selectable frequency outputs and alarms
- **See Also:**
 - ISL12057 (uses crystal: 6pF || load capacitance)
 - ISL12059 (F_{OUT} = 512Hz, no alarm)



Add Battery Backup to a Low Cost RTC Without a V_{BAT} Input

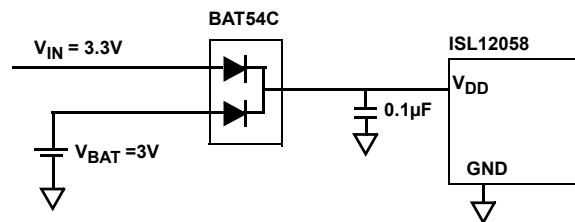

Device	I _{BAT} (nA)	Alarms	Selectable Frequency Output	CPU Supervisory Function		Battery		IRQ	F _{OUT}	SRAM	Other Functions	Package
				POR	Watchdog Timer	Seal	Backup					
With Battery Backup												
ISL12008	800	1	1	N	N	Y	Y	-	Dedicated Pin			8 Ld SOIC
With Battery Backed SRAM												
ISL1208	400	1	15	N	N	Y	Y	Shared Pin		2 Bytes		8 Ld MSOP, 8 Ld SOIC, 8 Ld TDFN
ISL1218	400	1	15	N	N	Y	Y	Shared Pin		8 Bytes		8 Ld MSOP, 8 Ld SOIC
ISL1220	400	1	15	N	N	Y	Y	Dedicated Pin	Dedicated Pin	8 Bytes		10 Ld MSOP
With Battery Backed SRAM and Event Detection												
ISL1209	400	1	15	N	N	Y	Y	Shared Pin		2 Bytes	• Event Detect	10 Ld MSOP
ISL1219	400	1	15	N	N	Y	Y	Shared Pin		2 Bytes	• Event Detect • Time Stamp	10 Ld MSOP
ISL1221	400	1	15	N	N	Y	Y	Dedicated Pin	Dedicated Pin	2 Bytes	• Event Detect • Time Stamp	10 Ld MSOP
With IRQs, Alarm and Timer												
ISL12057	400	2	4	N	N	N	N	Shared Pin		N	• 3V	8 Ld SOIC, 8 Ld MSOP, 8 Ld TDFN
ISL12058	400	2	4	N	N	N	N	Shared Pin		N	• 3V	8 Ld SOIC, 8 Ld MSOP, 8 Ld TDFN, 8 Ld μ TDFN
ISL12059	400	0	1	N	N	N	N	Shared Pin		N	• 3V	8 Ld SOIC
ISL12082	800	1	4	N	N	Y	Y	Dedicated Pin	Dedicated Pin	N	• Alarm • Timer	10 Ld MSOP, 8 Ld SOIC

Switches/MUXes

- USB Switch
- High Voltage ($\pm 15V$) MUXes
- Medium Voltage ($\pm 6V$, +3 to +12V) Switches/MUXes
- Low Voltage ($< 6V$) Switches/MUXes
- USB/Audio Switch

► USB Switch

High-Speed USB 2.0 (480Mbps) Multiplexer: ISL54222A

USB Switches with Charge Pump for High Speed Data Transfer

Key Features

- USB 2.0 High Speed Compliant
- Charge Pump Design
- Low R_{ON} and Capacitance
- Low Leakage During Power Down
- Low Supply Current Power Down Mode
- Tiny μ TQFN Packaging

Applications

- Photo Mini-Printers
- MP3 and Other Personal Media Players
- Cellular/Mobile Phones
- PDAs
- Audio/USB Switching Applications

Low Supply Voltage

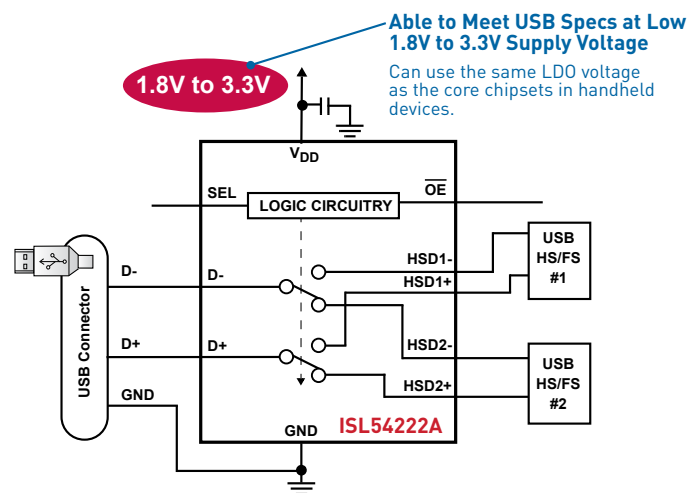

USB Switches

Device	Device Description	Configuration	R_{ON} (Ω)	Con (pF)	V_{DD} (V)	I_s (μ A)	Package
ISL54200	USB 2.0 High/Full Speed Multiplexer	HS/FS	7	12 @ 1MHz	2.7 to 5.5	0.02	10 Ld TDFN, 10 Ld μ TQFN
ISL54216	USB 2.0 High-Speed/UART Dual SP3T (Dual 3 to 1 Multiplexer)	HS/HS/HS	5.6	2.75 @ 240MHz	2.7 to 4.6	6.5	12 Ld TQFN, 12 Ld μ TQFN
ISL54220	High-Speed USB 2.0 (480Mbps) Multiplexer	HS/HS	6.7	4.2 @ 240MHz	2.7 to 5.5	0.03	10 Ld MSOP, 10 Ld TDFN, 10 Ld μ TQFN
ISL54221	High-Speed USB 2.0 (480Mbps) Multiplexer	HS/HS	6.7	4.2 @ 240MHz	2.0 to 5.5	1	10 Ld μ TQFN
ISL54222A	High-Speed USB 2.0 (480Mbps) Multiplexer	HS/HS	4.4	4.2 @ 240MHz	1.8 to 3.3	5.8	10 Ld MSOP, 10 Ld TDFN, 10 Ld μ TQFN
ISL54224	High-Speed USB 2.0 (480Mbps) Multiplexer with Overvoltage Protection (OVP) and Overvoltage Indicator Output	HS/HS	6.5	3.3 @ 240MHz	2.7 to 5.25	23	10 Ld TDFN, 10 Ld μ TQFN
ISL54225	High-Speed USB 2.0 (480Mbps) Multiplexer with Overvoltage Protection (OVP)	HS/HS	6.5	3.3 @ 240MHz	2.7 to 5.25	23	10 Ld TDFN, 10 Ld μ TQFN
ISL54226	High-Speed USB 2.0 (480Mbps) DPST Switch with Overvoltage Protection (OVP) and Dedicated Charger Port Detection	HS	3.5	2.0 @ 240MHz	2.7 to 5.25	23	8 Ld TDFN, 8 Ld μ TQFN
ISL54227	High-Speed USB 2.0 (480Mbps) DPST Switch with Overvoltage Protection (OVP) and Dedicated Charger Port Detection	HS	3.5	2.0 @ 240MHz	2.7 to 5.25	23	10 Ld TDFN, 10 Ld μ TQFN
ISL54228	High-Speed USB 2.0 (480Mbps) DPST Switch with Overvoltage Protection (OVP)	HS	3.5	2.0 @ 240MHz	2.7 to 5.25	23	8 Ld TDFN, 8 Ld μ TQFN
ISL54230	Octal Multiprotocol Switch	HS/HS/FS/UART	1.26/8	8.3 @ 1MHz	2.0 to 5.5	1	32 Ld TQFN, 36 Ld WLCSP
ISL54233	Wideband Differential 3:1 Multiplexer	HS/HS/HS	5.6	2.75 @ 240MHz	2.7 to 4.6	6.5	12 Ld TQFN, 12 Ld μ TQFN
ISL76120	Automotive Grade USB 2.0 High/Full Speed Multiplexer	HS/FS	7	12 @ 1MHz	2.7 to 5.5	0.02	10 Ld TDFN

► High Voltage ($\pm 15V$) MUXes with OVP

Programmable Logic Controller (PLC)

Intersil has a broad portfolio of industrial multiplexers and switch's to meet the requirements of most signal path applications. From Over Voltage Protected, $\pm 15V$ to medium voltage families in a wide variety of configurations, we have a part to fit your application.

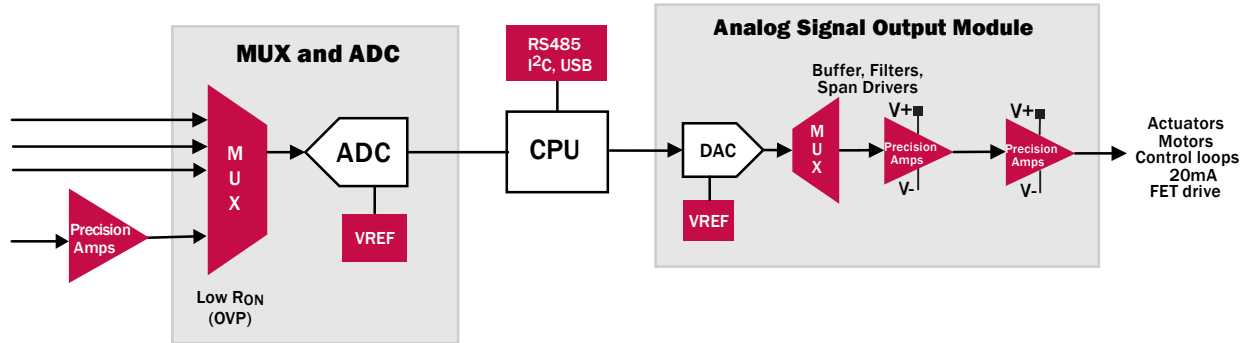

$\pm 15V$ MUXes with OVP

	Device	Switches	Configuration		Ron	Con	Package	Notes
Duals	HI-5042	2	DPST	Mix	50	22	16 CDIP	
	HI-200	2	SPST	NC	55	11	14 CDIP, PDIP	
	HI-0303	2	DPST	MIX	35	35	14 CDIP, PDIP, SOIC	
	HI-390	2	DPST	Mix	35	35	16 CDIP, PDIP	
	HI-5043	2	DPST	Mix	50	22	16 CDIP, PDIP, SOIC	
	HI-5051	2	DPST	Mix	25	22	16 CDIP, PDIP, SOIC	
	DG401	2	SPST	NO	20	39	16 PDIP, SOIC, TSSOP	Logic Supply Pin
Quads	DG403	2	SPST	NC	20	39	16 PDIP, SOIC, TSSOP	Logic Supply Pin
	HI-0201	4	SPST	NC	55	11	16 CDIP, PDIP, SOIC, 20 PLCC	
	HI-0201HS	4	SPST	NC	30	30	16 CDIP, PDIP, SOIC	
	DG411	4	SPST	NC	25	35	16 PDIP, SOIC, TSSOP	Logic Supply Pin
	DG412	4	SPST	NO	25	35	16 PDIP, SOIC, TSSOP	Logic Supply Pin
	DG413	4	SPST	MIX	25	35	16 PDIP, SOIC, TSSOP	Logic Supply Pin
	DG441	4	SPST	NC	50	16	16 PDIP, SOIC, TSSOP	Logic Supply Pin
	DG442	4	SPST	NO	50	16	16 PDIP, SOIC, TSSOP	Logic Supply Pin
4:1	DG444	4	SPST	NC	50	16	16 PDIP, SOIC, TSSOP	
	DG445	4	SPST	NO	50	16	16 PDIP, SOIC, TSSOP	
	HI-509	8	Diff	4:1	180	12	16 CDIP, PDIP, SOIC, 20 PLCC	
	HI-509A	8	Diff	4:1	1200	12	16 CDIP, PDIP	
8:1	HI-549	8	Diff	4:1	1200	12	16 CDIP, PDIP, SOIC, 20 PLCC	Over-Voltage Protected Matched Ron
	DG409	8	Diff	4:1	180	12	16 PDIP, SOIC, TSSOP	
	HI-508	8	Single	8:1	180	17	16 CDIP, PDIP, SOIC, 20 PLCC	
	HI-508A	8	Single	8:1	1200	25	16 CDIP, PDIP	Over-Voltage Protected
	HI-548	8	Single	8:1	1200	25	16 CDIP, PDIP, SOIC, 20 PLCC	Over-Voltage Protected Matched Ron
	HI-518	8	8:1	2x4:1	480	10	18 PDIP	Programmable
	HI-507	16	Diff	8:1	180	30	28 CDIP, PDIP, PLCC	
	HI-507A	16	Diff	8:1	1200	30	28 PDIP	Over-Voltage Protected
16:1	DG407	16	Diff	8:1	180	17	28 PDIP, PLCC, SOIC	
	DG408	8	Single	8:1	480	10	16 CDIP, PDIP, SOIC, TSSOP	
	HI-547	16	Single	16:1	1200	30	28 CDIP, PDIP, SOIC, PLCC	Over-Voltage Protected Matched Ron
	HI-506	16	Single	16:1	180	52	28 CDIP, PDIP, SOIC, PLCC	
	HI-506A	16	Single	16:1	1200	52	28 CDIP, PDIP, PLCC	Over-Voltage Protected
	HI-546	16	Single	16:1	1200	52	28 CDIP, PDIP, SOIC, PLCC	Over-Voltage Protected Matched Ron
	HI-516	16	16:1	2x8:1	620	25	28 PDIP	Programmable
	DG406	16	Single	16:1	1200	30	28 PDIP, SOIC	

► Medium Voltage ($\pm 6V$, +3 to +12V) Switches/MUXes

$\pm 6V$, +3 to +12V Switches/MUXes

	Device	Switches	Configuration		Ron	Con	Package	Notes
Single	ISL43110	1	SPST	NO	7	40	5 SOT23, 8 SOIC	
	ISL43111	1	SPST	NC	7	40	5 SOT23, 8 SOIC	
	ISL43112	1	SPST	NO	15	30	5 SOT23, 8 SOIC	
	ISL43113	1	SPST	NC	15	30	5 SOT23, 8 SOIC	
	ISL84514	1	SPST	NO	10	30	5 SOT23, 8 SOIC	
	ISL84515	1	SPST	NC	10	30	5 SOT23, 8 SOIC	
	ISL84516	1	SPST	NO	13	22	5 SOT23, 8 SOIC	
	ISL84517	1	SPST	NC	13	22	5 SOT23, 8 SOIC	
	ISL43210	2	SPDT	2:1	11	28	6 SOT23	
	ISL43210A	2	SPDT	2:1	11	28	6 SOT23	15V Extended Supply Range
	ISL5123	2	SPDT	2:1	11	28	8 SOIC	
ISL84544	2	SPDT	2:1	30	20	6 SOT23, 8 SOIC		
Duals	ISL43120	2	SPST	NO	11	21	8 SOT23	
	ISL43121	2	SPST	NC	11	21	8 SOT23	
	ISL43122	2	SPST	MIX	11	21	8 SOT23	
	ISL5120	2	SPST	NO	11	21	8 SOIC, SOT23	
	ISL5121	2	SPST	NC	11	21	8 SOIC, SOT23	
	ISL5122	2	SPST	MIX	11	21	8 SOIC, SOT23	
	ISL8323	2	SPST	NO	60	22	8 SOIC	
	ISL8324	2	SPST	NC	60	22	8 SOIC	
	ISL8325	2	SPST	MIX	60	22	8 SOIC	
	ISL84541	2	SPST	NO	30	13	8 MSOP, PDIP, SOIC, SOT23	
	ISL84542	2	SPST	NC	30	13	8 PDIP, SOIC, SOT23	
	ISL84543	2	SPST	MIX	30	13	8 PDIP, SOIC, SOT23	
	ISL43410	4	DPDT	2:1	45	12	16 QFN, SOIC, TSSOP	
ISL84525	4	DPDT	2:1	92	12	10 MSOP		
Triples	ISL43231	6	SPDT	2:1	44	14	20 QFN	
	ISL84053	6	SPDT	2:1	60	14	16 QSOP, SOIC, TSSOP	
Quads	ISL43140	4	SPST	NC	50	14	16 QFN, SOIC, TSSOP	
	ISL43141	4	SPST	NO	50	14	16 QFN, SOIC, TSSOP	
	ISL43142	4	SPST	MIX	50	14	16 QFN, SOIC, TSSOP	
	ISL43143	4	SPST	NC	18	34	16 QFN, TSSOP	
	ISL43144	4	SPST	NO	18	34	16 QFN, TSSOP	
	ISL43145	4	SPST	MIX	18	34	16 QFN, TSSOP	
	ISL8391	4	SPST	NC	20	34	16 SOIC	
	ISL8392	4	SPST	NO	20	34	16 SOIC	
	ISL8393	4	SPST	MIX	20	34	16 SOIC	
	ISL84521	4	SPST	NC	65	5	16 QFN, SOIC, TSSOP	
	ISL84522	4	SPST	NO	65	5	16 QFN, SOIC, TSSOP	
	ISL84523	4	SPST	MIX	65	5	16 QFN, SOIC, TSSOP	
	ISL54302	4	SPST	NO	1.5	100	20 QFN	Latched Parallel Interface
	ISL43240	4	SPDT	2:1	18	30	20 QFN, SSOP	
ISL8394	4	SPDT	2:1	17	39	20 SOIC		
4:1	ISL43640	4	Single	4:1	39	18	16 MSOP, QFN	
	ISL84524	4	Single	4:1	92	20	10 MSOP	
	ISL43741	8	Diff	4:1	39	18	20 QFN	
	ISL43840	8	Dual	4:1	39	18	20 QFN	
	ISL84052	8	Diff	4:1	60	18	16 QSOP, SOIC, TSSOP	
	ISL84582	8	Diff	4:1	44	18	16 TSSOP	
8:1	ISL84051	8	Single	8:1	60	26	16 QSOP, SOIC, TSSOP	
	ISL84581	8	Single	8:1	39	26	16 QSOP, TSSOP	

► Low Voltage(<6V) Switches/MUXes

+1.1V to 4.5V, Sub Ω Switches/MUXes

	Device	Switches	Configuration		Ron	Con	Package	Notes
Single	ISL43L110	1	SPST	NO	0.24	160	5 SC70	
	ISL43L111	1	SPST	NC	0.24	160	5 SC70	
	ISL84715	1	SPST	NO	0.26	160	5 SC70	
	ISL84716	1	SPST	NC	0.26	160	5 SC70	
	ISL43L210	2	SPDT	2:1	0.38	110	6 SC70	
	ISL84714	2	SPDT	2:1	0.44	100	6 SC70	
Dual	ISL43L120	2	SPST	NO	0.16	290	8 MSOP, TDFN	
	ISL43L121	2	SPST	NC	0.16	290	8 MSOP, TDFN	
	ISL43L122	2	SPST	MIX	0.16	290	8 MSOP, TDFN	
	ISL43L710	2	DPST	NO	0.17	290	8 MSOP, TDFN	
	ISL43L712	2	DPST	MIX	0.17	290	8 MSOP, TDFN	
	ISL54047	2	DPST	NO	0.45	233	10 μ TQFN	T-Switch. High Off Isolation
	ISL54048	2	DPST	NO	0.29	176	10 μ TQFN	
	ISL54049	2	DPST	NC	0.29	176	10 μ TQFN	
	ISL43L220	4	SPDT	2:1	0.22	224	10 TDFN	
	ISL43L410	4	DPDT	2:1	0.25	224	10 MSOP, TDFN	
	ISL54049	4	SPDT	2:1	0.29	176	10 μ TQFN	
	ISL54050	4	SPDT	2:1	0.3	176	10 μ TQFN	
	ISL84684	4	SPDT	2:1	0.29	224	10 MSOP, TDFN	
	ISL84684II	4	SPDT	2:1	0.27	355	10 CSP	
ISL84762	4	SPDT	2:1	0.35	224	10 MSOP, TDFN		
ISL8484	4	SPDT	2:1	0.3	176	10 MSOP, TDFN		
Quads	ISL43L420	8	DPDT	2:1	0.25	212	16 QFN	
	ISL54056	8	DPDT	2:1	0.4	102	16 μ TQFN	
	ISL83699	8	DPDT	2:1	0.3	212	16 TQFN, TSSOP	
	ISL84467	8	DPDT	2:1	0.4	102	16 TQFN, TSSOP	
	ISL84780	8	DPDT	2:1	0.4	125	16 QFN, TSSOP	
	ISL8499	8	DPDT	2:1	0.26	212	16 QFN, TQFN, TSSOP	
4:1	ISL43L840	8	Dual	4:1	0.5	232	16 QFN, TSSOP	
	ISL43L841	8	Diff	4:1	0.47	232	16 QFN	
	ISL54057	8	Diff	4:1	0.45	233	16 μ TQFN	
	ISL54058	8	Dual	4:1	0.29	176	16 μ TQFN	
	ISL84782	8	Diff	4:1	0.29	176	16 QFN, TSSOP	
8:1	ISL84781	8	Single	8:1	0.41	485	16 QFN, TSSOP	

+1.8V to 6.5V Switches/MUXes

	Device	Switches	Configuration		Ron	Con	Package	Notes
Single	ISL54051	1	SPST	NO	0.86	48	6 SOT23, μ TDFN	
	ISL54052	1	SPST	NC	0.86	48	6 SOT23, μ TDFN	
	ISL54054	1	SPST	NO	0.36	62	6 SOT23, μ TDFN	
	ISL54055	1	SPST	NC	0.36	62	6 μ TDFN	
	ISL54501	1	SPST	NO	5	12	6 SOT23, μ TDFN	
	ISL54502	1	SPST	NC	5	12	6 SOT23, μ TDFN	
	ISL54504	1	SPST	NO	2.5	18	6 SOT23, μ TDFN	
	ISL54505	1	SPST	NC	2.5	18	6 SOT23, μ TDFN	
	ISL54053	2	SPDT	2:1	0.86	48	6 SOT23, μ TDFN	
	ISL54500	2	SPDT	2:1	5	12	6 SOT23, μ TDFN	
	ISL54503	2	SPDT	2:1	2.5	18	6 SOT23, μ TDFN	
Duals with Negative Signal Swing	ISL54059	4	SPDT	2:1	0.52	100	10 TDFN, μ TQFN	
	ISL54060	2	SPST	NO	0.52	100	10 TDFN, μ TQFN	
	ISL54061	2	SPST	NC	0.52	100	10 TDFN, μ TQFN	
	ISL54062	4	SPDT	2:1	0.55	88	10 TDFN, μ TQFN	Click & Pop Elimination
	ISL54063	2	SPST	NO	0.55	88	10 TDFN, μ TQFN	Click & Pop Elimination
	ISL54064	2	SPST	NC	0.55	88	10 TDFN, μ TQFN	Click & Pop Elimination
	ISL54065	4	SPDT	2:1	0.52	88	12 μ TQFN	Selectable Click & Pop Elimination. All switches open mode
	ISL54066	2	SPST	NO	1	124	10 TDFN, μ TQFN	T-Switch. High Off Isolation
	ISL54405	4	DPDT	2:1	1.9	27	16 TQFN, TSSOP, μ TQFN	Very Low THD, Click & Pop Elimination

Compact, Single Pole/Triple Throw Switches Eliminate Handheld Device Connector Congestion

- Negative Input Signal Handling
 - Compatible with single supply capacitor coupled portable devices
- High Off-Isolation Mute Mode
 - Eliminates click and pop during power up and down
- Tiny 2.2x1.4mm μ TQFN Packaging
 - Significant reduction in space occupied compared to discrete solutions

Applications

- Cellphones
- Smartphones
- PDAs
- MP3/4 Players

Two High Speed USB Ports and a Low Distortion 'Click and Pop' Free Audio Port

Dual USB 2.0 High Speed (480Mbps) Data Paths

- Allows multiple chips to share a High Speed USB port
- 2nd USB port can be used for UART data

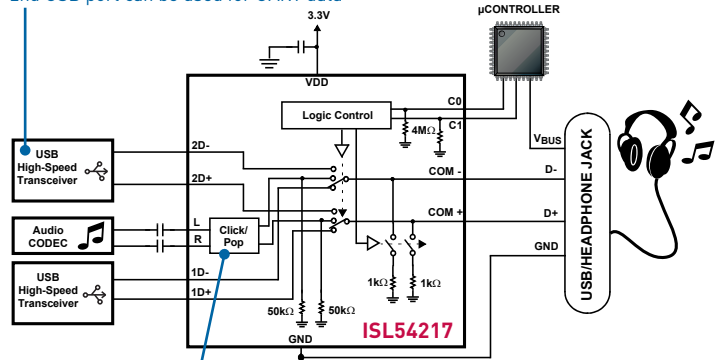

Audio Click and Pop Elimination

Removes annoying audio artifacts from the listening experience.

Ultra Low Distortion (<0.03% THD+N)

Ultra Low Distortion Audio Signal Switching

Allows switching and muting of MP3 quality audio sources.

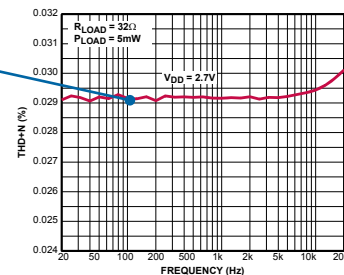

USB/Audio Switches

	Device	Switches	Configuration	Ron (audio)	Ron (USB)	Con @ 1MHz	Package	Notes
USB 2.0 Full Speed	ISL54400	4	DPDT 2:1	1	5	46	10 TDFN, μ TQFN	
	ISL54401	4	DPDT 2:1	1	5	46	10 TDFN, μ TQFN	
	ISL54402	4	DPDT 2:1	1	5	46	10 TDFN, μ TQFN	
	ISL54415	4	DPDT 2:1	1	5	46	10 μ TQFN	Video Capability
	ISL54416	4	DPDT 2:1	1	5	46	10 μ TQFN	Video Capability
	ISL54417	4	DPDT 2:1	1	7.5	46	10 μ TQFN	Video Capability
USB 2.0 High Speed	ISL54409	2	DPST NO	2.4	5.4	4.2*	8 TDFN, μ TQFN	
	ISL54410	2	DPST NO	2.4	5.4	4.2*	8 TDFN, μ TQFN	Click & Pop Elimination
	ISL54205B	4	DPDT 2:1	2.65	4.6	10	10 TDFN, μ TQFN	
	ISL54206A	4	DPDT 2:1	2.65	4.6	10	10 TDFN, μ TQFN	
	ISL54207	4	DPDT 2:1	2.65	4.6	10	10 TDFN, μ TQFN	Video Capability
	ISL54208	4	DPDT 2:1	2.65	4.6	10	10 TDFN, μ TQFN	Video Capability
	ISL54209	4	DPDT 2:1	2.5	5	8	10 TDFN, μ TQFN	
	ISL54210	4	DPDT 2:1	2.4	5.4	4.2*	10 TDFN, μ TQFN	Click & Pop Elimination
	ISL54211	4	DPDT 2:1	2.4	5.4	4.2*	10 TDFN, μ TQFN	Click & Pop Elimination
	ISL54212	4	DPDT 2:1	2.65	4.6	10	10 TDFN, μ TQFN	
	ISL54213	4	DPDT 2:1	2.5	5.5	8	10 TDFN, μ TQFN	
	ISL54215	4	DPDT 2:1	2.5	5	7	10 μ TQFN	
	ISL54214	6	DP3T 3:1	2.3	6.2	8	12 TDFN, μ TQFN	
ISL54217	6	DP3T 3:1	2.3	6.2	8	12 TDFN, μ TQFN	Click & Pop Elimination	

* @ 240MHz

Interface

► RS-232

Intersil offers a broad portfolio of robust, wide operating voltage range, RS-232 transceivers. There are many transmitter and receiver combinations in standard inline packages plus space saving QFN package options as well. Most operate over a wide 2.7V to 5.5V supply range with a variety of power down modes.

RS-232 Transceiver in Ultra Small QFN Package

Key Features

- Wide Power Supply Range: +2.7V to +5.5V
- Very Low, 300µA Supply Current
- Meets EIA/TIA-232 Specifications Down to $V_{CC} = 3.0V$
- Ultra Small QFN Package
 - 40% smaller package than 20-lead TSSOP

Typical Operating Circuits

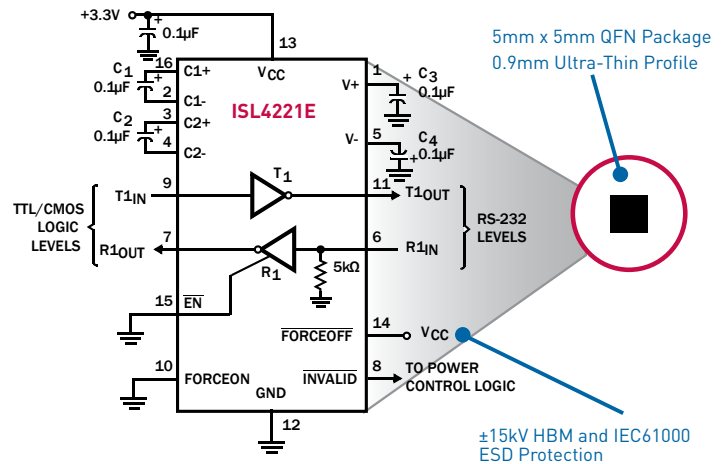

+3V to +5V, RS-232 IEC-61000 ESD-Protected Transceivers in QFN Package

Device	No. of Tx.	No. of Rx.	Data Rate (kbps)	Rx. Enable Function?	Manual Power-down?	Automatic Power-down?	V_L
ISL4221E	1	1	250	Yes	Yes	Yes	No
ISL3232E	2	2	250	No	No	No	No
ISL4223E	2	2	250	Yes	Yes	Yes	No
ISL4260E	3	2	250	No	Yes	Yes	No
ISL4270E	3	3	250	No	Yes	Yes	No
ISL4238E	5	3	250	No	Yes	Yes	No
ISL4243E	3	5	250	No	Yes	Yes	No
ISL3241E	3	5	250	Yes	Yes	No	Yes
ISL3243E	3	5	250	No	Yes	No	Yes

+3V to +5.5V, ESD-Protected Transmitters/Receivers

Device	# of Tx	# of Rx	High ESD	Manual Shutdown	Auto Shutdown	Rx Disable	Data Rate (Mbps)	Cap. Value (µF)	I_S Enabled (mA)	I_S Disabled (µA)	V_{CC} Range (V)	Package
ICL3207E	5	3	Yes	No	No	No	0.3	0.1	0.3	N/A	3 to 5.5	24 Ld SOIC, 24 Ld SSOP
ICL3217E	5	3	Yes	No	Basic	No	0.3	0.1	0.3	1	3 to 5.5	24 Ld SOIC, 24 Ld SSOP
ICL3221E	1	1	Yes	Yes	Basic	Yes	0.5	0.1	0.3	1	3 to 5.5	16 Ld SSOP, 16 Ld TSSOP
ICL3221EM	1	1	Yes	Yes	Basic	Yes	0.5	0.1	0.3	1	0 to 3.6	16 Ld TSSOP
ICL3222E	2	2	Yes	Yes	No	Yes	0.5	0.1	0.3	1	3 to 5.5	18 Ld SOIC, 20 Ld SSOP, 20 Ld TSSOP
ICL3223E	2	2	Yes	Yes	Basic	Yes	0.5	0.1	0.3	1	3 to 5.5	20 Ld SSOP, 20 Ld TSSOP
ICL3224E	2	2	Yes	Yes	Enhanced	No	0.5	0.1	0.3	1	3 to 5.5	20 Ld SSOP
ICL3225E	2	2	Yes	Yes	Enhanced	No	1	0.1	0.3	1	3 to 5.5	20 Ld PDIP, 20 Ld SSOP
ICL3226E	1	1	Yes	Yes	Enhanced	No	0.5	0.1	0.3	1	3 to 5.5	16 Ld SSOP
ICL3227E	1	1	Yes	Yes	Enhanced	No	1	0.1	0.3	1	3 to 5.5	16 Ld SSOP
ICL3232E	2	2	Yes	No	No	No	0.5	0.1	0.3	N/A	3 to 5.5	16 Ld SOIC, 16 Ld SSOP, 16 Ld TSSOP, 20 Ld TSSOP
ICL3237E	5	3	Yes	Yes	No	Yes	0.5/1.0	0.1	0.3	0.01	3 to 5.5	28 Ld SSOP
ICL3238E	5	3	Yes	Yes	Enhanced	No	0.5	0.1	0.3	0.01	3 to 5.5	28 Ld SSOP, 28 Ld TSSOP
ICL3241E	3	5	Yes	Yes	No	Yes	0.5	0.1	0.3	1	3 to 5.5	28 Ld SOIC, 28 Ld SSOP, 28 Ld TSSOP
ICL3243E	3	5	Yes	Yes	Basic	No	0.5	0.1	0.3	1	3 to 5.5	28 Ld SOIC, 28 Ld SSOP, 28 Ld TSSOP
ICL3244E	3	5	Yes	Yes	Enhanced	No	0.5	0.1	0.3	1	3 to 5.5	28 Ld SSOP
ICL3245E	3	5	Yes	Yes	Enhanced	No	1	0.1	0.3	1	3 to 5.5	28 Ld SOIC, 28 Ld SSOP, 28 Ld TSSOP

► RS-485/422

Intersil offers a broad portfolio of robust RS-485/422 devices that have the basic 485 protocol features or enhanced features that add to product reliability. With supply voltage ranges from 1.8V to 5.5V you can find about any kind of differential solution to fit your application.

1.8V, Micro Power Single Tx, Rx and Transceivers RS-485/422

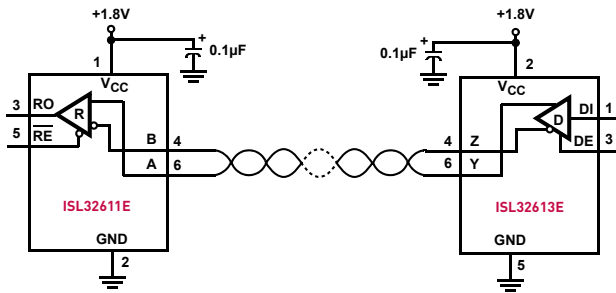

1.8V RS-485/422 Tx, Rx, and Transceivers with Ultra Low Supply Current for Remote or Solar Powered Sensor Communication

Device	Tx	Rx	Supply Range	Data Rate kbps	I_{CC} (μ A) max	Shut-down Current (μ A) max	ESD rating	Pkg
ISL32610E	0	1	1.8-3.6V	256/500	110	7	IEC61000	SOT23
ISL32611E	0	1	1.8-3.6V	256/500	110	7	IEC61000	SOT23
ISL32612E	0	1	1.8-3.6V	256/500	110	7	IEC61000	SOT23
ISL32613E	1	0	1.8-3.6V	256/500	80	2	IEC61000	SOT23
ISL32614E	1	0	1.8-3.6V	256/500	80	2	IEC61000	SOT23
ISL3260xE (coming soon)	1	1	1.8-3.6V	128/460	85	1	IEC61000	SOIC/MSOP

+3V to +5V, RS-485/422 Transceivers, Transmitters, Receivers

Basic Features

Device	5V	3V	Dr	Rec	Half Dup	Full Dup	SRL kbps	Hi Speed Mbps	125C temp	FailSafe Open	Fract UL	High ESD
ISL848x	Y		1	1	Y	Y	250	5		Y	32	
ISL848xE	Y		1	1	Y	Y	250	5	8485E	Y	32	15kV HBM
ISL4485E	Y		1	1	Y			20		Y	32	15kV HBM
ISL4489/91E	Y		1	1		Y	250	15		Y	256	15kV HBM
ISL8x487	Y		1	1	Y		250	5		Y	256	
ISL8348x		Y	1	1	Y	Y	250	10		Y	32	
ISL43485		Y	1	1	Y			30		Y	32	
ISL81485/86	Y		1	1	Y			30		Y	32	
ISL4486	Y		1	1	Y			40		Y	32	

Enhanced Features

Device	5V	3V	Dr	Rec	Half Dup	Full Dup	SRL kbps	Hi Speed Mbps	125C temp	Full Fail Safe	Fract UL	High ESD	Hot Plug
ISL8308xE	Y		1	1	Y	Y	115/ 500	10		Y	256	15kV HBM	Y
ISL8307xE		Y	1	1	Y	Y	250/500	20		Y	256	15kV HBM	Y
ISL315xE	Y		1	1	Y	Y	115/1M	20/40	3159	Y	256	IEC61000	Y
ISL317xE		Y	1	1	Y	Y	250/500	20/40	3179	Y	256	IEC61000	Y
ISL328xE	Y	Y		1				20	Y	Y	256	IEC61000	
ISL329xE	Y	Y	1				250/500	20	Y		256	IEC61000	Y
ISL32x73/5/7E	Y	Y		4				80	Y		128	IEC61000	
ISL32x72/4E	Y	Y	4				460	10/32	Y		256	IEC61000	Y
ISL3259E	Y		1	1	Y			100	Y	Y	160	IEC61000	Y

Over Voltage Protected to 60V

Device	5V	3V	Dr	Rec	Half Dup	Full Dup	SRL kbps	Hi Speed Mbps	Wide Vcm	Full Fail Safe	Fract UL	High ESD	Hot Plug
ISL3149xE	Y		1	1	Y	Y	250/1000	15	\pm 25	Y	128		Y
ISL3148xE	Y		1	1	Y	Y	1000		\pm 25/ Polarity reversal	Y	128		Y
ISL3147xE	Y		1	1	Y	Y	250/1000	15	\pm 15	Y	128		Y
ISL3245xE*		Y	1	1	Y	Y	250/1000		\pm 20	Y	128	15kV HBM	
ISL3249x	Y		1	1	Y	Y	250/1000	15	\pm 25	Y	128	15kV HBM	Y
ISL3248x	Y		1	1	Y	Y	1000		\pm 25/ Polarity reversal	Y	128	15kV HBM	Y
ISL3247x	Y		1	1	Y	Y	250/1000	15	\pm 15	Y	128	15kV HBM	Y

* Coming soon.

Transceiver Family with the Highest Noise Immunity and ESD Protection in Small Packages

Enhanced Noise Immunity

60% Higher Output Voltage (ISL315xE)

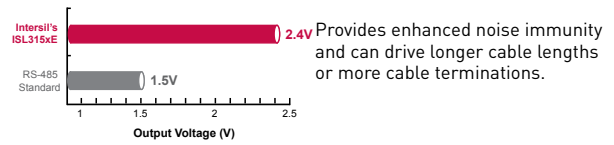

Key Features

- 60% Higher Output Voltage. 2.4V min vs. typical 1.5V min
- IEC61000 ESD Protected I/O Pins
- True 1/8 Unit Load

Applications

- Electronic Utility Meter Reading Systems, E-meter
- Industrial Air Conditioning Systems
- PROFIBUS and Factory Automation

Space-saving Small Package

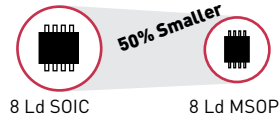

Typical Operating Circuit

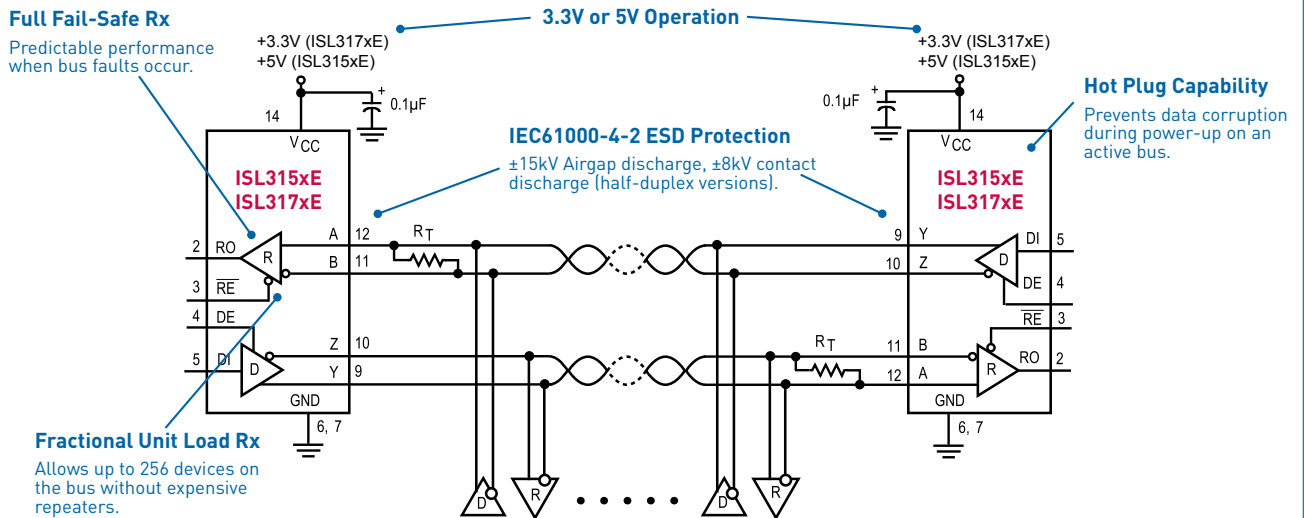

Device	Devices Allowed on Bus	Half/Full Duplex	Hot Plug	Data Rate (Mbps)	Slew Rate Limited	Tx/Rx Enable	I _S EN/DIS (µA)	SHDN I _{CC} (µA)	V _{CC} Range (+V)	Package
5.5V, Fractional UL, 15kV ESD, Full Failsafe										
ISL3150E	256	Full	Yes	0.115	Yes	Yes	800/700	0.07	4.5 to 5.5	10 Ld MSOP, 14 Ld SOIC
ISL3152E	256	Half	Yes	0.115	Yes	Yes	800/700	0.07	4.5 to 5.5	8 Ld MSOP, 8 Ld PDIP, 8 Ld SOIC
ISL3153E	256	Full	Yes	1	Yes	Yes	800/700	0.07	4.5 to 5.5	10 Ld MSOP, 14 Ld SOIC
ISL3155E	256	Half	Yes	1	Yes	Yes	800/700	0.07	4.5 to 5.5	8 Ld MSOP, 8 Ld SOIC
ISL3156E	256	Full	Yes	20	No	Yes	800/700	0.07	4.5 to 5.5	10 Ld MSOP, 14 Ld SOIC
ISL3158E	256	Half	Yes	20	No	Yes	800/700	0.07	4.5 to 5.5	8 Ld MSOP, 8 Ld SOIC
3.3V, Fractional UL, 15kV ESD, Full Failsafe										
ISL3170E	256	Full	Yes	0.25	Yes	Yes	510/480	0.01	3.0 to 3.6	10 Ld MSOP, 14 Ld SOIC
ISL3172E	256	Half	Yes	0.25	Yes	Yes	510/480	0.01	3.0 to 3.6	8 Ld MSOP, 8 Ld SOIC
ISL3173E	256	Full	Yes	0.5	Yes	Yes	510/480	0.01	3.0 to 3.6	10 Ld MSOP, 14 Ld SOIC
ISL3175E	256	Half	Yes	0.5	Yes	Yes	510/480	0.01	3.0 to 3.6	8 Ld MSOP, 8 Ld SOIC
ISL3176E	256	Full	Yes	20	No	Yes	510/480	0.01	3.0 to 3.6	10 Ld MSOP, 14 Ld SOIC
ISL3178E	256	Half	Yes	20	No	Yes	510/480	0.01	3.0 to 3.6	8 Ld MSOP, 8 Ld SOIC

► Other Interface Products

Single Tx and Rx RS-485/422

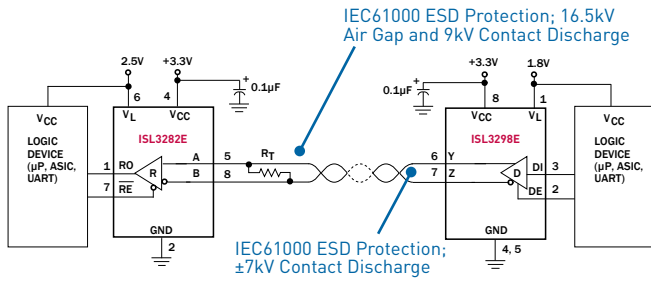

3.3V to 5.0V - Rx Only or Tx Only

Device	# of Tx / # of Rx	Devices Allowed on Bus	Hot Plug	Data Rate (Mbps)	V _{CC} Range (+V)	Package
ISL3280E	1 Rx	256	No	20	3.0 to 5.5	5 Ld SOT-23
ISL3282E	1 Rx with V _L Pin	256	No	20	3.0 to 5.5	8 Ld TDFN
ISL3283E	1 Rx	256	No	20	3.0 to 5.5	6 Ld SOT-23
ISL3296E	1 Tx with V _L Pin	256	Yes	0.25	3.0 to 5.5	8 Ld TDFN
ISL3297E	1 Tx with V _L Pin	256	Yes	0.5	3.0 to 5.5	8 Ld TDFN
ISL3298E	1 Tx with V _L Pin	256	Yes	20	3.0 to 5.5	8 Ld TDFN

Quad Tx and Rx RS-485/422

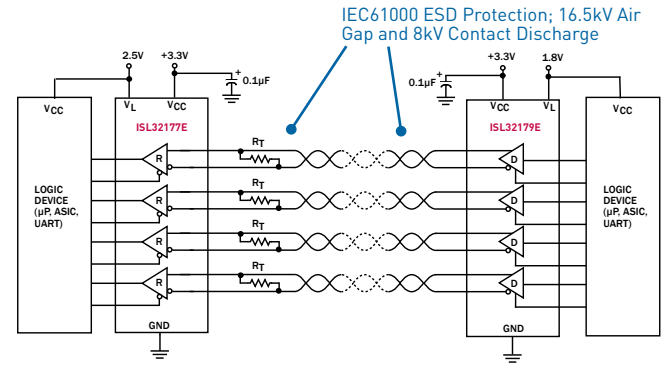

3.3V to 5.0V - Rx Only or Tx Only

Device	Function	Data Rate (Mbps)	Rx Enable Type
ISL32177E	4 Rx	80	Individual and group enables
ISL32273E	4 Rx	20	EN, EN
ISL32277E	4 Rx	20	Individual and group enables
ISL32172E	4 Tx	32	EN, EN
ISL32372E	4 Tx	0.46	EN, EN
ISL32179E	4 Tx	32, 10, 0.46	Individual and group enables

Dual Protocol Transceivers

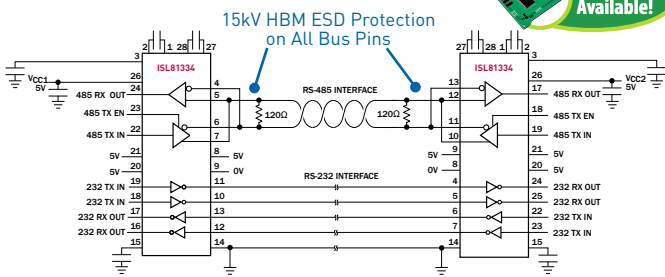

Multi-Protocol - RS-232 and RS-485

Device	Supported Protocols	# of Ports	# of Tx/Rx per Port	Data Rate RS-485/RS-232 (Mbps)	V _{CC} (V)	Package
ISL41334	RS-232, RS-422, RS-485	2	1/1 RS-485, RS-422; 2/2 RS-232	20, 0.46, 0.115/0.5	5, 3.3	40 Ld QFN
ISL41387	RS-232, RS-422, RS-485	1	1/1 RS-485, RS-422; 2/2 RS-232	20, 0.46, 0.115/0.5	5, 3.3	40 Ld QFN
ISL81334	RS-232, RS-422, RS-485	2	1/1 RS-485, RS-422; 2/2 RS-232	20/0.5	5, 3.3	28 Ld SOIC, 28 Ld SSOP
ISL81387	RS-232, RS-422, RS-485	1	1/1 RS-485, RS-422; 2/2 RS-232	20, 0.46/0.5	5, 3.3	20 Ld SOIC, 20 Ld SSOP

OVP RS-485

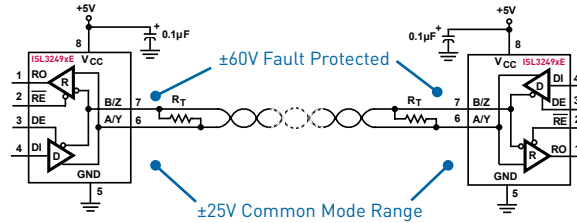

5V, RS-485/RS-422 Transceivers

Device	Half/Full Duplex	Data Rate (Mbps)	Half/Full Duplex	EN Pins?	Hot Plug?	Quiescent ICC (mA)	Low Power SHDN?	Pin Count
ISL32490E	Full	0.25	Yes	Yes	Yes	2.3	Yes	10, 14
ISL32492E	Half	0.25	Yes	Yes	Yes	2.3	Yes	8
ISL32493E	Full	1	Yes	Yes	Yes	2.3	Yes	10, 14
ISL32495E	Half	1	Yes	Yes	Yes	2.3	Yes	8
ISL32498E	Half	15	No	Yes	Yes	2.3	Yes	8

I²C Buffers

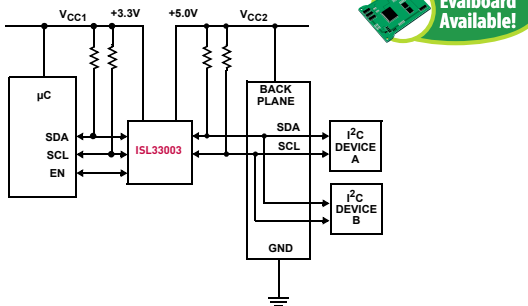

Device	Level Translation	EN Pin	Ready Pin	Accelerator Disable
ISL33001	No	Yes	Yes	No
ISL33002	Yes	No	No	Yes
ISL33003	Yes	Yes	No	No

Voltage Level Translators

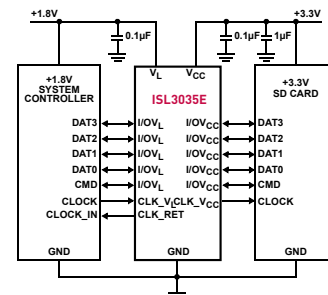

Device	Data Rate (Mbps)	Number Of Channels	EN Pin	I/OV _L SHDN State	I/OV _{CC} SHDN State
ISL3034E	100	6	YES	16.5kΩ to V _L	16.5kΩ to V _{CC}
ISL3035E	100	6	NO	75kΩ to V _L	High Impedance
ISL3036E	100	4	YES	16.5kΩ to V _L	16.5kΩ to V _{CC}

Digital Potentiometers

DCPs Enable Digitally Controlled Analog Signal Processing

DCPs allow for digital flexibility in an analog circuit. DCPs provide a link between the digital and analog domains in the system, allowing repeatable control and configuration of analog circuitry. This approach is typically more power-efficient than computationally intensive digital signal processing. For more information, please see AN133.

Digitally Programmable

- Voltage Amplifier
- Filter
- Voltage Reference
- Voltage Regulator

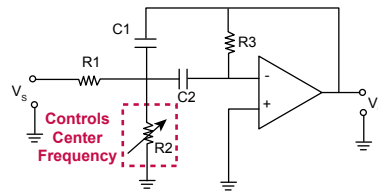

Tunable Bandpass Filter IGMF Model

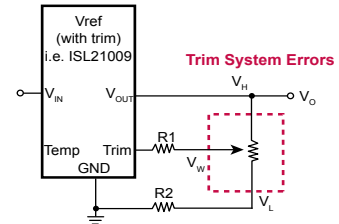

Trimmable Voltage Reference

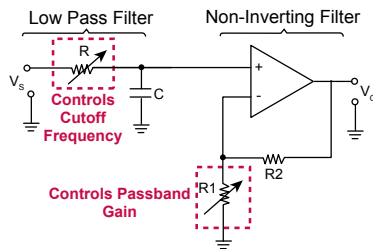

Programmable Filter and Gain Block

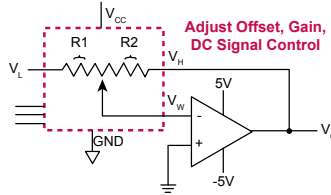

Programmable Inverting Amplifier

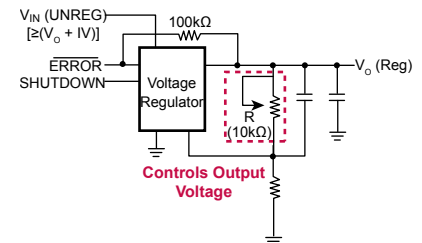

Programmable Voltage Regulator

Volatile: ISL233x5, ISL234x5, ISL233x8, ISL234x8

128-tap and 256-tap I²C and SPI Volatile Digital Potentiometers

Lowest Voltage

Specification	Intersil	Competition	Benefit
Analog Voltage	1.7V to 5.5V	1.8V to 5.5V 2.7V to 5.5V	Operational when battery starts draining.
Digital Voltage	1.2V to 5.5V	Same as analog voltage, lowest is 1.8V	Eliminate level shifter for I ² C/SPI when μ C has low voltage I/O pins.
Low Current Consumption	2.5 μ A - 1CH 3 μ A - 2CH 5 μ A - 4CH	Up to 2x more power consumption	Drains up to 50% less battery power.

Smaller Package

Type	Part #	Intersil	Competition	Benefit
Single	ISL23315, ISL23415, ISL23318, ISL23418	μ TQFN (2.1x1.6mm)	SC-70 (2x2.1mm)	20% Smaller
Dual	ISL23325, ISL23425, ISL23328, ISL23428	μ TQFN (2.6x1.8mm)	QFN (4x4mm)	48% Smaller
Quad	ISL23345, ISL23445, ISL23348, ISL23448	QFN (3x4mm)	QFN (4x4mm)	25% Smaller

Also offered in leaded packages for easy design-in

Vref Adjustment

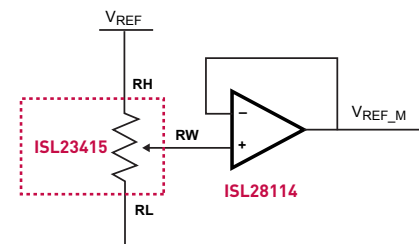

Adjust Both Charge Current and Input Current on Portable Devices

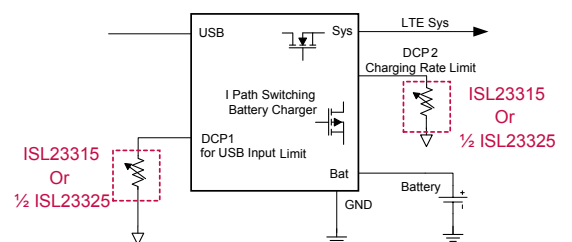

Intersil DCP Quick Reference

Non-Volatile (EEPROM Memory)

<ul style="list-style-type: none"> → Single 16-Tap (4-Bits) X9116 - 10kΩ, Up-Down ISL22512 - 10kΩ, Push Button → Single 32-Tap (5-Bits) ☐ X9313 - 1kΩ / 10kΩ / 50kΩ, Up-Down ☐ X9314 - 10kΩ, Log Taper, Up-Down X9315 - 10kΩ / 50kΩ / 100kΩ, Up-Down X93154 - 50kΩ, Up-Down, 2-Terminal X93155 - 50kΩ, Up-Down, 2-Terminal X93156 - 12.5kΩ / 50kΩ, Up-Down ☐ X9511 - 10kΩ, Push Button ISL22511 - 10kΩ / 50kΩ, Push Button → Single 64-Tap (6-Bits) X9429 - 2.5kΩ / 10kΩ, 2-Wire → Single 100-Tap (~6.65-Bits) X9317 - 1kΩ / 10kΩ / 50kΩ / 100kΩ, Up-Down ☐ X9318 - 10kΩ, Up-Down ☐ X9319 - 10kΩ / 50kΩ / 100kΩ, Up-Down ☐ X9C102 - 1kΩ, Up-Down ☐ X9C103 - 10kΩ, Up-Down ☐ X9C104 - 100kΩ, Up-Down ☐ X9C503 - 50kΩ, Up-Down ☐ X9C303 - 32kΩ, Log Taper, Up-Down → Single 128-Tap (7-Bits) ISL22316 - 10kΩ / 50kΩ, I²C ISL22317 - 10kΩ / 50kΩ / 100kΩ, 1% Tolerance, I²C ISL22319 - 10kΩ / 50kΩ, I²C, Wiper Only ☐ ISL95311 - 10kΩ / 50kΩ, I²C ☐ ISL95711 - 10kΩ / 50kΩ, I²C ISL96017 - 10kΩ / 50kΩ, I²C (16kbits extra EEPROM) ISL22416 - 10kΩ / 50kΩ, SPI ISL22419 - 10kΩ / 50kΩ, SPI, Wiper Only ☐ ISL95310 - 10kΩ / 50kΩ, Up-Down ☐ ISL95710 - 10kΩ / 50kΩ, Up-Down → Single 256-Tap (8-Bits) ISL95810 - 10kΩ / 50kΩ, I²C ISL95811 - 10kΩ / 50kΩ, I²C ☐ ISL22313 - 10kΩ / 50kΩ / 100kΩ, I²C ☐ ISL22414 - 10kΩ / 50kΩ / 100kΩ, SPI → Single 1024-Tap (10-Bits) ☐ X9110 - 100kΩ, SPI X9111 - 100kΩ, SPI ☐ X9118 - 100kΩ, 2-Wire X9119 - 100kΩ, 2-Wire 	<ul style="list-style-type: none"> → Dual 32-Tap (5-Bits) X93254 - 50kΩ, Up-Down, 2-Terminal X93255 - 50kΩ, Up-Down, 2-Terminal X93256 - 50kΩ, Up-Down → Dual 64-Tap (6-Bits) ☐ X9410 - 10kΩ, SPI ☐ X9221A - 2kΩ / 10kΩ / 50kΩ, 2-Wire ☐ X9418 - 2.5kΩ / 10kΩ, 2-Wire → Dual 128-Tap (7-Bits) ISL22326 - 10kΩ / 50kΩ, I²C ISL22329 - 10kΩ / 50kΩ, I²C, Wiper Only ISL22426 - 10kΩ / 50kΩ, SPI ISL22429 - 10kΩ / 50kΩ, SPI, Wiper Only → Dual 256-Tap (8-Bits) X95820 - 10kΩ / 50kΩ, I²C ☐ X9260 - 50kΩ / 100kΩ, SPI X9261 - 50kΩ / 100kΩ, SPI ☐ X9268 - 50kΩ / 100kΩ, 2-Wire ☐ ISL22323 - 10kΩ / 50kΩ / 100kΩ, I²C ☐ ISL22424 - 10kΩ / 50kΩ / 100kΩ, SPI 	<ul style="list-style-type: none"> → Quad 64-Tap (6-Bits) ☐ X9400 - 2.5kΩ / 10kΩ, SPI X9401 - 10kΩ, SPI ☐ X9241A - 2kΩ / 10kΩ / 50kΩ, 2-Wire ☐ X9408 - 2.5kΩ / 10kΩ, 2-Wire X9409 - 2.5kΩ / 10kΩ, 2-Wire → Quad 128-Tap (7-Bits) ISL22346 - 10kΩ / 50kΩ, I²C ISL22349 - 10kΩ / 50kΩ, I²C, Wiper Only ISL22446 - 10kΩ / 50kΩ, SPI ISL22449 - 10kΩ / 50kΩ, SPI, Wiper Only → Quad 256-Tap (8-Bits) X95840 - 10kΩ / 50kΩ, I²C ☐ X9250 - 50kΩ / 100kΩ, SPI X9251 - 50kΩ / 100kΩ, SPI X9252 - 2kΩ / 10kΩ / 50kΩ / 100kΩ, 2-Wire ☐ X9258 - 50kΩ / 100kΩ, 2-Wire X9259 - 50kΩ / 100kΩ, 2-Wire ☐ ISL22343 - 10kΩ / 50kΩ / 100kΩ, I²C ☐ ISL22444 - 10kΩ / 50kΩ / 100kΩ, SPI
<h3>Special Function DCPs</h3> <ul style="list-style-type: none"> → Dual Audio DCP - Integrated Output Buffer Amps and Audio Detect ISL22102 - 32kΩ, Log Taper, Push Button, 0 to -72dB Dynamic Range → Low Voltage 1% Tolerant Precision DCP & Low Temperature Coefficient ISL22317 - 10kΩ / 50kΩ / 100kΩ, I²C → Programmable Voltage Reference X60250 - Micro-power, 8-bit Adjustable, 0 to 1.25V ISL21400 - Programmable Gain and Temperature Slope → Sensor Conditioners with ADC, E²PROM Look-Up Tables, and DACs X96010 - Dual, 2-Wire X96011 - Single with Temperature Sensor, 2-Wire X96012 - Dual with Temperature Sensor, 2-Wire → Single 128-Tap DCP with 16kbits General Purpose E²PROM ISL96017 - 10kΩ / 50kΩ, I²C → TFT/LCD Programmable V_{COM} Calibrator (128 Step) ISL45041 - I²C ISL45042 - Up-Down 		

Volatile (No EEPROM Memory)

<ul style="list-style-type: none"> → Single 16-Tap (4-Bits) ISL23512 - 10kΩ, Push Button → Single 32-Tap (5-Bits) X9015 - 10kΩ / 50kΩ / 100kΩ, Up-Down ISL23511 - 10kΩ / 50kΩ, Push Button ISL90460 - 10kΩ / 50kΩ / 100kΩ, Up-Down, Rheostat ISL90461 - 10kΩ / 50kΩ / 100kΩ, Up-Down, 2-Terminal ISL90462 - 10kΩ / 50kΩ / 100kΩ, Up-Down, 2-Terminal → Single 128-Tap (7-Bits) ISL90726 - 10kΩ / 50kΩ, I²C, 2-Terminal ISL90727/28 - 10kΩ / 50kΩ, I²C, 2-Terminal NEW ISL23318 - 10kΩ / 50kΩ / 100kΩ, I²C, Low Voltage NEW ISL23418 - 10kΩ / 50kΩ / 100kΩ, SPI, Low Voltage ☐ ISL23711 - 10kΩ / 50kΩ, I²C ☐ ISL23710 - 10kΩ / 50kΩ, Up-Down → Single 256-Tap (8-Bits) ISL90810 - 10kΩ / 50kΩ, I²C ISL23315 - 10kΩ / 50kΩ / 100kΩ, I²C, Low Voltage ISL23415 - 10kΩ / 50kΩ / 100kΩ, SPI, Low Voltage 	<ul style="list-style-type: none"> → Dual 32-Tap (5-Bits) ☐ X9460 - 32kΩ, Log Taper, 2-Wire ISL22102 - 32kΩ, Log Taper, Audio Detect, Push Button → Dual 128-Tap (7-Bits) NEW ISL23328 - 10kΩ / 50kΩ / 100kΩ, I²C, Low Voltage NEW ISL23428 - 10kΩ / 50kΩ / 100kΩ, SPI, Low Voltage → Dual 256-Tap (8-Bits) ISL23325 - 10kΩ / 50kΩ / 100kΩ, I²C, Low Voltage ISL23425 - 10kΩ / 50kΩ / 100kΩ, SPI, Low Voltage 	<ul style="list-style-type: none"> → Quad 128-Tap (7-Bits) NEW ISL23348 - 10kΩ / 50kΩ / 100kΩ, I²C, Low Voltage NEW ISL23448 - 10kΩ / 50kΩ / 100kΩ, SPI, Low Voltage → Quad 256-Tap (8-Bits) ISL23345 - 10kΩ / 50kΩ / 100kΩ, I²C, Low Voltage ISL23445 - 10kΩ / 50kΩ / 100kΩ, SPI, Low Voltage ISL90840 - 10kΩ / 50kΩ, I²C ISL90841 - 10kΩ / 50kΩ, I²C, 2-Terminal ISL90842 - 10kΩ / 50kΩ, I²C, 2-Terminal
<p>☐ Extended positive terminal voltage ☐ Positive and negative terminal voltage</p>		

High Speed Data Converter

► World's Lowest Power High-Performance ADCs

Intersil offers a complete portfolio of low-power, high-speed ADCs unmatched in size and power. Our innovative Femtocharge CMOS technology enables ultra-high performance at a fraction of the power of the competition.

Key Features

- **Comprehensive Portfolio: 8-16-Bits, 40-500MSPS**
 - 16-Bits: Lowest power 200 & 250MSPS ADCs
 - 14-Bits: Industry's first 14-Bit 500MSPS ADC
 - 12-Bits: Lowest power dual 12-Bit 250MSPS ADC
 - 10-Bits: Lowest power single and dual 250MSPS ADCs
 - 8-Bits: Highest performance 500MSPS ADC
- **Widest Breadth of Resolution/Sample Rate Amongst Pin-Compatible Families**
- **Superior Wideband Capabilities with High Input Bandwidth and Ultra-Low Clock Jitter**
- **Compact Footprint: All ADCs Offered in 7x7mm or 10x10mm QFNs**

Applications

- **Communications**
- **Networking**
- **Instrumentation**
- **Industrial**
- **Video and imaging**
- **Military**

High Speed ADCs

Part Number	Resolution (bits)	No. of Channels	Speed (MSPS)	SNR (dBfs)	Power* (mW)	Package Options (all QFN)	Interface
ISLA216P25	16	1	250	75.0	785	72 Ld	LVDS/CMOS
ISLA216S25	16	1	250	75.8	887	48 Ld	JESD204B
ISLA216P20	16	1	200	76.6	720	72 Ld	LVDS/CMOS
ISLA216S20	16	1	200	77.2	815	48 Ld	JESD204B
ISLA216P13	16	1	130	77.5	615	72 Ld	LVDS/CMOS
ISLA216S13	16	1	130	78.0	751	48 Ld	JESD204B
ISLA224P25	14	2	250	72.7	810	72 Ld	LVDS/CMOS
ISLA224S25	14	2	250	73.1	989	48 Ld	JESD204B
ISLA224P20	14	2	200	73.9	745	72 Ld	LVDS/CMOS
ISLA224S20	14	2	200	73.8	910	48 Ld	JESD204B
ISLA224P13	14	2	130	74.7	650	72 Ld	LVDS/CMOS
ISLA224P12	14	2	125	74.7	590	72 Ld	LVDS/CMOS
ISLA224P12	14	2	125	75.1	731	48 Ld	JESD204B
ISLA214P50	14	1	500	72.7	835	72 Ld	LVDS/CMOS
ISLA214S50	14	1	500	73.1	1060	48 Ld	JESD204B
ISLA214P25	14	1	250	73.0	450	72 Ld	LVDS/CMOS
KAD5514P-25	14	1	250	69.5	390	48 Ld, 72 Ld	LVDS/CMOS
KAD5514P-21	14	1	210	70.2	365	48 Ld, 72 Ld	LVDS/CMOS
ISLA214P20	14	1	200	73.8	410	72 Ld	LVDS/CMOS
KAD5514P-17	14	1	170	70.6	340	48 Ld, 72 Ld	LVDS/CMOS
ISLA214P13	14	1	130	74.9	360	72 Ld	LVDS/CMOS
ISLA214P12	14	1	125	74.9	310	72 Ld	LVDS/CMOS
KAD5514P-12	14	1	125	70.9	310	48 Ld, 72 Ld	LVDS/CMOS
ISLA222P25	12	2	250	70.3	795	72 Ld	LVDS/CMOS
ISLA222S25	12	2	250	70.6	989	48 Ld	JESD204B
KAD5612P-25	12	2	250	66.1	430	72 Ld	LVDS/CMOS
KAD5612P-21	12	2	210	66.6	405	72 Ld	LVDS/CMOS
ISLA222P20	12	2	200	71.0	730	72 Ld	LVDS/CMOS
ISLA222S20	12	2	200	71.2	910	48 Ld	JESD204B
KAD5612P-17	12	2	170	66.9	370	72 Ld	LVDS/CMOS
ISLA222P13	12	2	130	71.3	635	72 Ld	LVDS/CMOS
KAD5612P-12	12	2	125	67.2	340	72 Ld	LVDS/CMOS
ISLA222S12	12	2	125	71.7	731	48 Ld	JESD204B
ISLA212P50	12	1	500	70.3	820	72 Ld	LVDS/CMOS
ISLA112P50**	12	1	500	65.9	455	72 Ld	LVDS/CMOS
KAD5512P-50	12	1	500	65.9	430	72 Ld	LVDS/CMOS
ISLA212P25	12	1	250	70.5	440	72 Ld	LVDS/CMOS
KAD5512HP-25	12	1	250	68.3	390	48 Ld, 72 Ld	LVDS/CMOS

Part Number	Resolution (bits)	No. of Channels	Speed (MSPS)	SNR (dBfs)	Power* (mW)	Package Options (all QFN)	Interface
KAD5512P-25	12	1	250	66.1	235	48 Ld, 72 Ld	LVDS/CMOS
KAD5512HP-21	12	1	210	68.8	365	48 Ld, 72 Ld	LVDS/CMOS
KAD5512P-21	12	1	210	66.6	220	48 Ld, 72 Ld	LVDS/CMOS
ISLA212P20	12	1	200	71.0	405	72 Ld	LVDS/CMOS
KAD5512HP-17	12	1	170	69.1	340	48 Ld, 72 Ld	LVDS/CMOS
KAD5512P-17	12	1	170	66.9	205	48 Ld, 72 Ld	LVDS/CMOS
ISLA212P13	12	1	130	71.3	355	72 Ld	LVDS/CMOS
KAD5512HP-12	12	1	125	69.3	310	48 Ld, 72 Ld	LVDS/CMOS
KAD5512P-12	12	1	125	67.1	190	48 Ld, 72 Ld	LVDS/CMOS
KAD5610P-25	10	2	250	60.8	410	72 Ld	LVDS/CMOS
KAD5610P-21	10	2	210	60.8	385	72 Ld	LVDS/CMOS
KAD5610P-17	10	2	170	61.0	355	72 Ld	LVDS/CMOS
KAD5610P-12	10	2	125	60.8	325	72 Ld	LVDS/CMOS
ISLA110P50**	10	1	500	60.7	440	72 Ld	LVDS/CMOS
KAD5510P-50	10	1	500	60.7	415	72 Ld	LVDS/CMOS
KAD2710C-27	10	1	275	55.7	260	68 Ld	CMOS
KAD2710L-27	10	1	275	55.7	280	68 Ld	LVDS
KAD5510P-25	10	1	250	60.8	235	48 Ld	LVDS/CMOS
KAD5510P-21	10	1	210	60.8	220	48 Ld	LVDS/CMOS
KAD2710C-21	10	1	210	56.4	220	68 Ld	CMOS
KAD2710L-21	10	1	210	56.4	240	68 Ld	LVDS
KAD5510P-17	10	1	170	61.0	205	48 Ld	LVDS/CMOS
KAD2710C-17	10	1	170	56.6	200	68 Ld	CMOS
KAD2710L-17	10	1	170	56.6	215	68 Ld	LVDS
KAD5510P-12	10	1	125	61.0	190	48 Ld	LVDS/CMOS
KAD2710C-10	10	1	105	56.6	165	68 Ld	CMOS
KAD2710L-10	10	1	105	56.6	180	68 Ld	LVDS
ISLA118P50**	8	1	500	49.9	430	72 Ld	LVDS/CMOS
KAD2708L-35	8	1	350	49.0	325	68 Ld	LVDS
KAD2708C-27	8	1	275	49.5	260	68 Ld	CMOS
KAD2708L-27	8	1	275	49.5	275	68 Ld	LVDS
KAD2708C-21	8	1	210	49.5	220	68 Ld	CMOS
KAD2708L-21	8	1	210	49.5	235	68 Ld	LVDS
KAD2708C-17	8	1	170	49.5	200	68 Ld	CMOS
KAD2708L-17	8	1	170	49.5	210	68 Ld	LVDS
KAD2708C-10	8	1	105	49.5	165	68 Ld	CMOS
KAD2708L-10	8	1	105	49.5	170	68 Ld	LVDS

*3mA DDR LVDS Mode unless Specified for CMOS or Serial outputs.

**The ILSA11XXP50 family features internal interleaving calibration and is pin-similar to the KAD55XX family.



Industry's Fastest 14-Bit ADC

The ISLA214P50 is a 14-bit, 500MSPS ADC that consumes 63% less power while sampling at a rate 25% higher than any other 14-Bit ADC. The ISLA214P50 was designed using Intersil's proprietary FemtoCharge™ technology and operates from a 1.8V power supply. The converter's ultra-high sample rate and resolution improve sensitivity and accuracy, while the decrease in power consumption allows simplified thermal and power system design. This ADC also combines breakthrough performance with extensive configurability, making it one of the most flexible and easy-to-use ADCs on the market.

Key Features

- Highest Sample Rate 14-bit ADC
- Facilitating Design Re-Use and Reducing Time-to-Market, Pin-Compatible with Family of High Performance ADC:
 - ISLA216P – 16-Bit, 130/200/250MSPS
 - ISLA214P – 14-Bit, 130/200/250MSPS
 - ISLA212P50 – 12-Bit, 500MSPS
 - ISLA212P – 12-Bit 130/200/250MSPS
- Support for Multi-Channel Systems:
 - Fine gain/offset adjust for channel matching
 - Clock divider synchronous reset for channel synchronization
 - Optimized output timing for multi-channel system reliability
- Support for Under-sampling/High-IF Applications
 - 700MHz analog input bandwidth
 - 75fs clock jitter
 - Dynamic performance specified to 600MHz
- Industry-Leading Dynamic Performance

63% Less Power Consumption, 25% Higher Sampling Rate than Any Other 14-Bit ADC

Device	Sample Rate (MSPS)	SNR (dBFS)	Power (mW)
ISLA214P50	500	72.7	835
Nearest Competitor	400	70.3	2500

High SNR

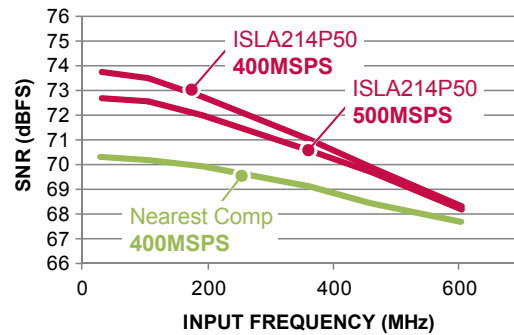

SNR vs. Input Frequency



Industry's Lowest Power 16-Bit, 250MSPS ADC

The ISLA216P is a series of low power, high performance 16-bit analog-to-digital converters. Designed with Intersil's proprietary FemtoCharge™ technology on a standard CMOS process, the series is the only pin-compatible family of 16-bit ADCs that support sampling rates from 40 to 250MSPS. The ISLA216P is part of a pin-compatible family of 12- to 16-bit ADCs with maximum sample rates ranging from 130 to 500MSPS.

The ISLA216P also provides multi-channel support so multiple ADCs can be matched precisely and aligned in time, simplifying the design of multi-channel systems. For advanced applications that benefit from multi-channel design, including data acquisition systems, radar array processing, broadband communications, software defined radios, and communications test equipment, the ISLA216P is an ideal choice.

Device	Sample Rate (MSPS)	SNR (dBFS)	SFDR (dBc)	ENOB (bits)	Power (mW)
ISLA216P25	250	75.0	87	12.1	786
ISLA216P20	200	76.6	91	12.4	706
ISLA216P13	130	77.5	96	12.6	603

Key Features

- Sample Rates from 40 to 250MSPS
- Designed for Ultra-Low Power
 - Single supply 1.8V operation
 - Total power consumption:
 - At 250MSPS = 786mW (40% less than competition)
 - At 200MSPS = 720mW (40% less than competition)
 - Nap and sleep modes
 - 200µs sleep wake-up time
- Designed for Ease of Use
 - SPI-programmable
 - Clock duty cycle stabilizer
 - Programmable 1/2/4x clock divider
 - Programmable built-in test patterns
 - User-accessible analog and digital temperature monitors
 - DDR LVDS-compatible or LVCMOS outputs
 - Two's complement, gray code, binary output data format
 - Data output clock provided
 - Pin-compatible devices for sample rates from 40 to 250MSPS



8-, 10-, 12-Bit, 500MSPS: ISLA118P50, ISLA110P50, ISLA112P50

Lowest Power, Highest Performance 8-, 10-, 12-Bit 500MSPS ADCs

The ISLA11xP50 are a series of low-power, high-performance 8-, 10-, and 12-Bit 500MSPS analog-to-digital converters designed with Intersil's proprietary FemtoCharge™ technology on a standard CMOS process. These devices are an upgrade of the KAD551XP-50 product family and are pin similar.

Device	SNR (dBFS)	SFDR (dBc)	ENOB (bits)	Power (mW)
ISLA112P50	65.9	86	10.7	455
ISLA110P50	60.7	86	9.8	441
ISLA118P50	49.9	68	8.0	428

Key Features

- Highest Performance 8-, 10-, and 12-Bit 500MSPS ADCs
- Lowest Power 10- & 12-Bit 500MSPS ADCs
- Only Pin-Compatible 8-, 10-, and 12-Bit 500MSPS ADCs
- Support for Multi-Channel Systems:
 - Fine gain/offset adjust for channel matching
 - Clock divider synchronous reset for channel synchronization
 - Optimized output timing for multi-channel system reliability
- Support for Under-sampling/High IF Applications
 - 1.15GHz analog input bandwidth
 - 60fs clock jitter
 - Dynamic performance specified to 1GHz

High SNR

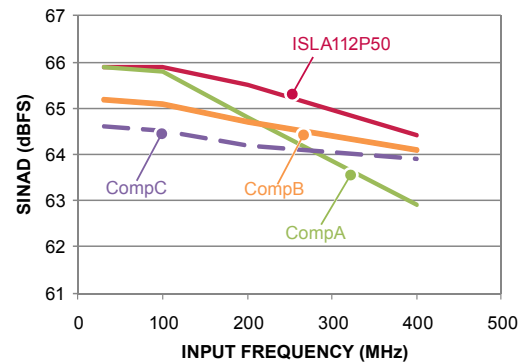

Lowest Power

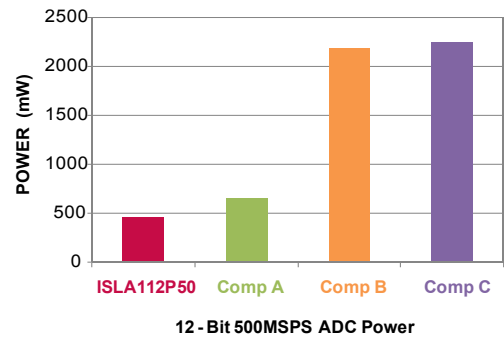

10- & 12-Bit, 250MSPS: KAD551xP, KAD561xP

Single and Dual-Channel, Highest Performance, Lowest Power 10-, 12-Bit 250MSPS ADCs

The KAD551xP and KAD561xP are a series of low-power, high-performance, single & dual-channel, 10- & 12-Bit, analog-to-digital converters. Designed with FemtoCharge™ technology on a standard CMOS process, the series supports sampling rates of up to 250MSPS. The KAD5x1xP-25 is the fastest member of this pin-compatible family, which also features sample rates of 210MSPS (KAD561xP-21/KAD551xP-21), 170MSPS (KAD561xP-17/KAD551xP-17) and 125MSPS (KAD561xP-12/KAD551xP-12).

Device	Channels	SNR (dBFS)	SFDR (dBc)	ENOB (bits)	Power (mW)
KAD5612P-25	2	66.0	86	10.7	429
KAD5512P-25	1	66.1	87	10.6	235
KAD5610P-25	2	60.7	86	9.8	411
KAD5510P-25	1	60.7	86	9.8	235

Key Features

- Lowest Power 10- & 12-Bit 250MSPS Single & Dual ADCs
- Highest Performance 10-Bit 250MSPS Single & Dual ADC
- Only Pin-Compatible 10- & 12-Bit Dual 250MSPS ADCs
- Programmable Gain, Offset and Skew for Channel-to-Channel Matching
- Support for Under-sampling/High IF Applications
 - 1.3GHz analog input bandwidth
 - 60fs clock jitter
 - Dynamic performance specified to 1GHz

Applications

- Portable Instrumentation
- High Performance Data Acquisition
- Power Amplifier Linearization
- Radar and Satellite Antenna Array Processing
- Broadband Communications
- Communications Test Equipment
- WiMAX and Microwave Receivers

► High Speed DACs

Intersil offers a broad portfolio of low-power, high-speed DACs, with sample rates from 60 to 260MSPS and resolutions from 8 to 14 bits. With excellent spurious free dynamic range and multi-tone intermodulation distortion, these D/A converters are ideal for today's demanding communications applications.

Key Features

- Excellent Dynamic Performance (ISL5957):
- Nyquist SFDR at 10MHz = 75dBc
- UMTS ACPR at 19.2MHz = 71dB
- GSM SFDR at 11MHz (20MHz window) = 94dBc
 - +3.3V supply, low power 103mW @130MSPS
 - Adjustable full-scale output current (2 to 20mA)
 - Pin compatible family of single & duals

Applications

- Wireless Communications
- Broadband Microwave Repeaters
- Military & SDR Radios

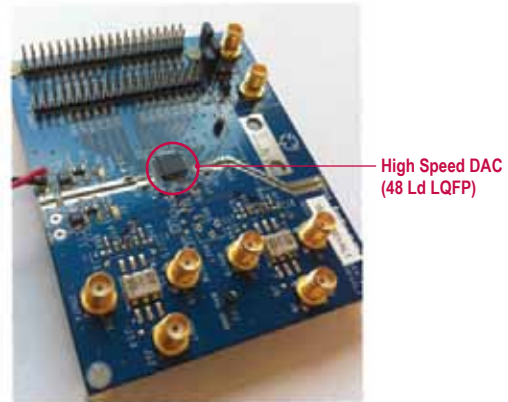

ISL5x27 Evaluation Kit

High Speed Digital to Analog Converters (DACs) (≥60MSPS)

Device	Resolution (Bits)	Conv. Rate (MSPS)	Power Supply V_s (Range) (V)	INL (max) (\pm LSB)	DNL (max) (\pm LSB)	SFDR (typ) to Nyquist F_{OUT} @ Sample Rate	Power (mW)	V_{REF}	Package
14-Bit - 1-Channel									
ISL5957	14	260	3.3	5	3	75dBc 10MHz@130MSPS	157mW at 260MSPS	Int/Ext	28 Ld SOIC, 28 Ld TSSOP
ISL5961	14	210, 130	3.3	5	3	75dBc 10MHz@130MSPS	110mW at 200MSPS	Int/Ext	28 Ld SOIC, 28 Ld TSSOP
HI5960	14	130	+3 to +5	5	3	77dBc 2.5MHz@50MSPS	84mW at 130MSPS (3V)	Int/Ext	28 Ld SOIC, 28 Ld TSSOP
HI5741	14	100	5, -5.2	1.5	1	74dBc 5.1MHz@50MSPS	650mW at 100MSPS	Int	28 Ld SOIC
14-Bit - 2-Channel									
ISL5927	14x2	260	3.3	5	3	75dBc 10MHz@130MSPS	275mW at 260MSPS	Int/Ext	48 Ld LQFP
ISL5929	14x2	210, 130	3.3	5	3	75dBc 10MHz@130MSPS	253mW at 200MSPS	Int/Ext	48 Ld LQFP
12-Bit - 1-Channel									
ISL5857	12	260	3.3	1.25	1	73dBc 10MHz@130MSPS	157mW at 260MSPS	Int/Ext	28 Ld SOIC, 28 Ld TSSOP
ISL5861	12	210, 130	3.3	1.25	1	73dBc 10MHz@130MSPS	110mW at 200MSPS	Int/Ext	28 Ld SOIC, 28 Ld TSSOP
HI5860	12	130	+3 to +5	2	1	76dBc 2.5MHz@50MSPS	32mW at 100MSPS (3V)	Int/Ext	28 Ld SOIC
HI5731	12	100	5, -5.2	1.5	1	69dBc 2MHz@100MSPS	650mW at 100MSPS	Int/Ext	28 Ld PDIP, 28 Ld SOIC
HI5735	12	80	5, -5.2	1.5	1	70dBc 2MHz@80MSPS	650mW at 80MSPS	Int/Ext	28 Ld SOIC
12-Bit - 2-Channel									
ISL5827	12x2	260	3.3	1.25	1	73dBc 10MHz@130MSPS	275mW at 260MSPS	Int/Ext	48 Ld LQFP
ISL5829	12x2	210, 130	3.3	1.25	1	73dBc 10MHz@130MSPS	253mW at 200MSPS	Int/Ext	48 Ld LQFP
10-Bit - 1-Channel									
ISL5757	10	260	3.3	0.5	0.5	71dBc 10MHz@130MSPS	157mW at 260MSPS	Int/Ext	28 Ld SOIC, 28 Ld TSSOP
ISL5761	10	210, 130	3.3	0.5	0.5	71dBc 10MHz@130MSPS	110mW at 200MSPS	Int/Ext	28 Ld SOIC, 28 Ld TSSOP
HI5760	10	60, 125	+3 to +5	1	0.5	68dBc 5MHz@100MSPS	27mW at 100MSPS (3V)	Int/Ext	28 Ld SOIC, 28 Ld TSSOP
10-Bit - 2-Channel									
ISL5727	10x2	260	3.3	0.5	0.5	70dBc 10MHz@130MSPS	275mW at 260MSPS	Int/Ext	48 Ld LQFP
ISL5729	10x2	130, 210	3.3	0.5	0.5	70dBc 10MHz@130MSPS	253mW at 200MSPS	Int/Ext	48 Ld LQFP
8-Bit - 1-Channel									
HI5660	8	125, 60	+3 to +5	0.5	0.5	61dBc 10.1MHz@125MSPS	27mW at 100MSPS (3V)	Int	28 Ld SOIC, 28 Ld TSSOP
8-Bit - 2-Channel									
ISL5627	8x2	260	3.3	0.5	0.5	67dBc 10MHz@130MSPS	275mW at 260MSPS	Int/Ext	48 Ld LQFP
ISL5629	8x2	210, 130	3.3	0.5	0.5	67dBc 10MHz@130MSPS	253mW at 200MSPS	Int/Ext	48 Ld LQFP
HI5628	8x2	125, 60	+3 to +5	0.5	0.5	61dBc 10.1MHz@125MSPS	54mW at 100MSPS (3V)	Int/Ext	48 Ld LQFP

Precision Data Converters

Following a long legacy of popular high-performance products, Intersil's precision data converter product offerings for Industrial and Instrumentation applications are expanding rapidly. All utilize robust state-of-the-art submicron mixed-signal processes which allow us to offer industry-leading performance and cost-effective feature sets, with competitive specifications which ensure measurement accuracy and longevity in the industrial environment.

24-bit Delta-Sigma Converters

- Weigh scales
- Dynamic weighing
- Manufacturing systems
- Temperature and load sensors
- Load safety systems
- Scientific instrumentation

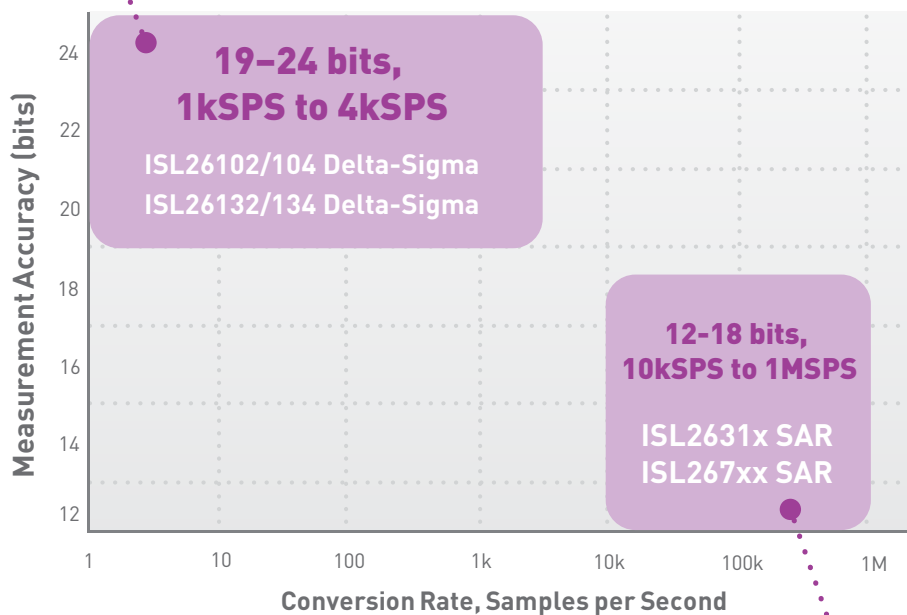

SAR Converters

- Process controllers
- Human-machine interface devices
- Pressure and flow sensors
- Switchgear
- Safety monitors
- Robotic controls
- Automotive systems



Coming Soon!

Industry-Leading Noise Performance Up to 4000SPS with Full Firmware Programmability

Key Features

- Best-in-Class Performance
- Lowest Noise over 2.5SPS-4000SPS
- Low Noise PGA with Buffer
 - Just 5.6nV/√Hz at 1Hz
- Simultaneous 50/60 Hz Noise Rejection
- 2 & 4 Ch Differential Input Multiplexer
 - AVDD Monitor, Onboard Temperature Sensor
- Low Power
 - 5V Analog, 5.5V / 2.7V Digital Supplies
 - 50mW power dissipation, 1µA Shutdown mode
 - Low Side Power Switch manages Load Cell Power
- SPI Compatible Serial Interface
 - Access to Calibration Registers
- 24 / 28 Pin TSSOP Package
- Extended Industrial Temp Range (-40°C - 105°C)
- Robust ESD Rating - 8kV HBM

Low Noise

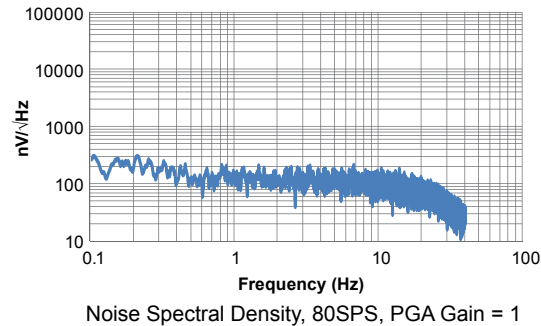

Highly Integrated

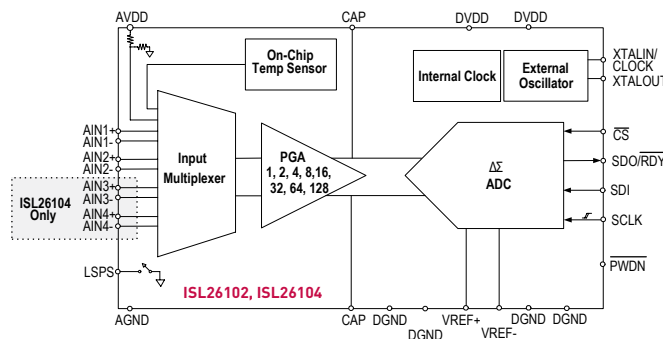

Easy to Use ADC with Excellent Noise Performance at Low Cost

Key Features

- Drop-In Compatible with ADS1232/34
 - Improved Performance with no change in circuitry
- 10SPS, 80SPS Operation
- Best in Class Performance – 21.6 Bits noise-free (Gain = 1)
- Low Noise PGA with Buffer
- Simultaneous 50/60 Hz Noise Rejection
- 2 & 4 Channel, Differential-input Multiplexer
- All Functions Pin-programmed
- Low Power: 53mW (max), 1µA in Shutdown mode
 - 5V Analog, 5.5V / 2.7V Digital Supplies
- Easy-to-Use SPI-compatible Serial Interface
- 24 / 28 Pin TSSOP Package
- Extended Industrial Temp Range (-40°C - 105°C)
- Robust ESD Rating – 7.5kV HBM
- Samples and Evaluation Board available

Low Noise

- At 10SPS, 128x Gain ISL26134 noise is 5.6nV/√Hz
- Competitor A shows 10.2nV/√Hz

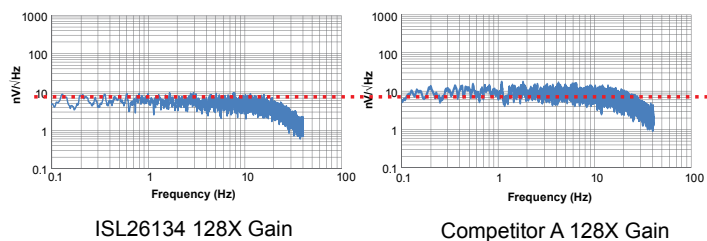

Highly Integrated

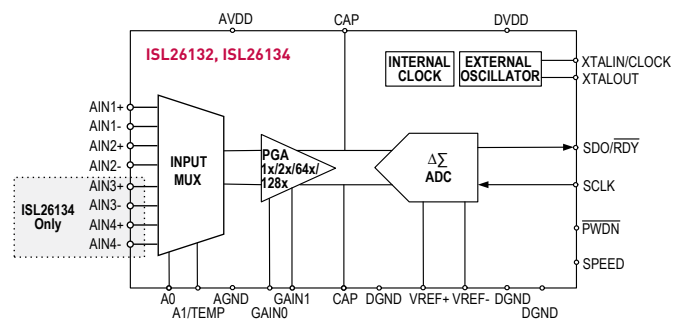

► 12-bit SAR

12-bit, 125kSPS – 250kSPS SAR: ISL2631x, ISL2632x

Easy to Use, Cost Effective SAR ADCs with 1, 2, 4, and 8-channel Inputs

The new ISL263xx family of multichannel-input SAR ADCs from Intersil offer a new level of cost-effectiveness and ease of use for all types of Industrial Process Control, Instrumentation, and related measurement applications. Input buffers that simplify input drive requirements and pin—compatibility across the entire product family make the family easy to design, and re-use across multiple platforms and product families.

Key Features

- Single, 2, 4, and 8-channel Multiplexed Inputs
- Single-Ended and Differential Input Versions
- Excellent Linearity: ± 0.7 LSB DNL, ± 0.7 LSB INL at 12 bits (max)
- Buffered Inputs Ease Input Drive Requirements, Reduce Solution Cost
- Pin-compatible Family Simplifies Re-use of Proven Designs
- Robust 5kV ESD Rating Perfect for Industrial Environments
- SPI Interface Connects to Popular Micros and FPGAs
- Specified for 2.7V to 5.5V Operation - Only 8mW at 3V
- Popular TSSOP and SOIC Packages
- Competitively Priced

Highly Integrated

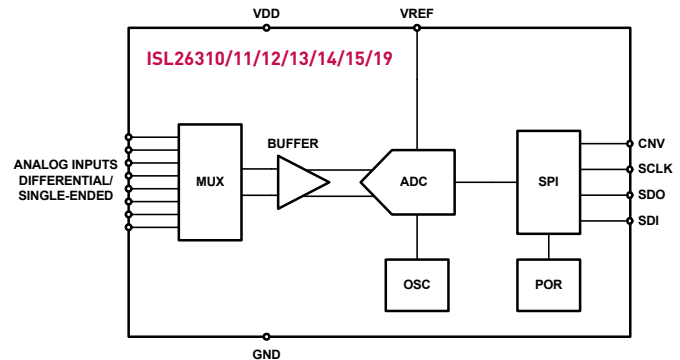

Superior Linearity Specifications

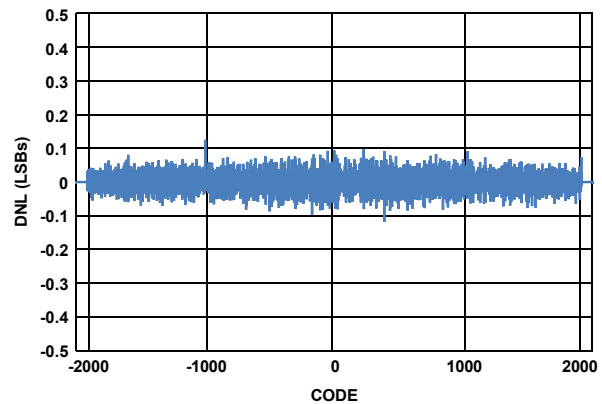

DIFFERENTIAL NONLINEARITY (DNL) vs CODE

	Single channel		2-channel		4-channel		8-channel
	Differential	Single-Ended	Differential	Single-ended	Differential	Single-ended	Single-ended
	8L SOIC	8L SOIC	16L TSSOP	8L SOIC	16L TSSOP	16L TSSOP	16L TSSOP
125ksps	ISL26310FBZ	ISL26311FBZ	ISL26312FVZ	ISL26313FBZ	ISL26314FVZ	ISL26315FVZ	ISL26319FVZ
250ksps	ISL26320FBZ	ISL26321FBZ	ISL26322FVZ	ISL26323FBZ	ISL26324FVZ	ISL26325FVZ	ISL26329FVZ

A Perfect SAR A/D Converter for Low-Cost Industrial Applications

The new ISL267xx family of 1MSPS SAR ADCs offer users of popular single-channel 10 and 12-bit ADCs from ADI and TI a 100% compatibility drop-in alternative, featuring improved performance with a rugged 8kV ESD rating and a competitive price, in all popular 8-lead packages. This family also includes proprietary 8, 10, and 12-bit devices in industry-leading microTDFN packages, resulting in a unique combination of performance and compact size.

Key Features

- Upgrade to Popular ADI, TI Products
- 100% Drop-In Compatible with Performance Equal or Better Than Highest Grades
- 10 and 12-bit Resolution
- All Single-Channel Inputs
- 20kSPS to 1MSPS Conversion Rates
- Robust Design for Industrial Applications with 8kV ESD Rating
- Popular 8-lead MSOP, SOIC, and SOT-23 Packages
- Specified for Operation Over Industrial Temperature Range (-40°C-85°C)
- Competitively Priced
 - 1K resale \$3.99, 16% lower than competitors*
- Also Proprietary 8, 10, 12-bit 1MSPS Devices in 3x3mm μ TDFN

* at time of publication

Ultra Small Package

- 3x3mm 8 Ld μ TDFN



Superior ± 0.3 LSB (typ) Differential Non-Linearity

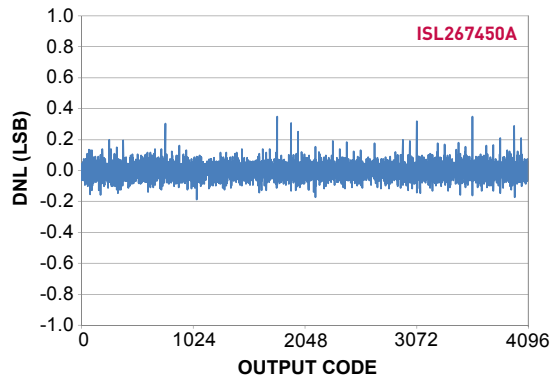

Block Diagram

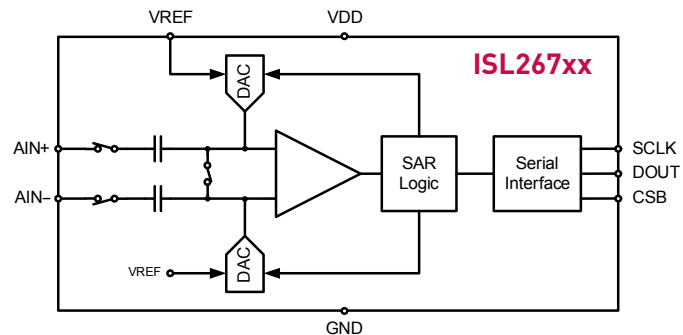

Intersil P/N	Competitor's P/N	Resolution (bits)	Conversion Rate (kSPS)	Packages (all 8 lead)
ISL267440	AD7440 (ADI)	10	1000	SOT-23, MSOP
ISL267450	AD7450 (ADI)	12	1000	SOIC, MSOP
ISL267450A	AD7450A (ADI)	12	1000	SOT-23, MSOP
ISL267452	AD7452 (ADI)	12	555	SOT-23
ISL2671286	ADS1286 (TI)	12	20	SOIC
ISL267817	ADS7817 (TI)	12	200	SOIC, MSOP
ISL26708	Upgrade	8	1000	3x3 μ TDFN, SOT-23
ISL26710	Upgrade	10	1000	3x3 μ TDFN, SOT-23
ISL26712	Upgrade	12	1000	3x3 μ TDFN, SOT-23

High Speed Op Amps

Intersil's high speed op amp portfolio delivers best in class performance-to-power ratio with superior drive and slew rate performance at full bandwidths. This makes our operational amplifiers the perfect choice for video and high speed data transmission, A/D buffering, and high frequency filtering.

Rail-to-Rail VFAs	Slew Rate Enhanced VFAs	Current Feedback Amplifiers	High Performance VFAs	Differential Line Drivers/Receivers	Fixed Gain Op Amps
Single Channel EL8100 200MHz, 200V/μs, EN EL8101 200MHz, 200V/μs	Single Channel EL5104 700MHz, 4,000V/μs, EN EL5105 700MHz, 4,000V/μs	Single Channel EL5160 200MHz, 1,700V/μs, EN EL5161 200MHz, 1,700V/μs EL5162 500MHz, 4,000V/μs, EN EL5163 500MHz, 4,000V/μs EL5164 600MHz, 4,700V/μs, EN EL5165 600MHz, 4,700V/μs EL5166 1400MHz, 6,000V/μs, EN EL5167 1400MHz, 6,000V/μs	High Supply Voltage Single Channel ISL55001 220MHz, 300V/μs ±2.5V to ±15V Dual Channel ISL55002 220MHz, 300V/μs ±2.5V to ±15V Quad Channel ISL55004 220MHz, 300V/μs ±2.5V to ±8V	Differential Line Drivers Single Channel EL5170 100MHz, 1,100V/μs Gain = 2, EN EL5171 250MHz, 800V/μs EL5173 400MHz, 900V/μs Gain = 2, EN EL5174 550MHz, 1,100V/μs, EN EL5176 250MHz, 800V/μs, EN EL5177 550MHz, 1,100V/μs EL5178 700MHz, 1,000V/μs	Single Channel EL5106 1.5mA supply current 350MHz, 4,500V/μs, ±1, 2 (Fixed Gain), EN EL5108 3.5mA supply current 450MHz, 4,500V/μs, ±1, 2 (Fixed Gain), EN
Dual Channel EL8200 200MHz, 200V/μs, EN EL8201 200MHz, 200V/μs EL8202 500MHz, 600V/μs, EN EL8203 500MHz, 600V/μs	Dual Channel EL5202 400MHz, 3,500V/μs, EN EL5203 400MHz, 3,500V/μs EL5204 700MHz, 4,000V/μs, EN EL5205 700MHz, 4,000V/μs	Dual Channel EL5260 200MHz, 2,000V/μs, EN EL5261 200MHz, 2,000V/μs EL5262 500MHz, 2,500V/μs, EN EL5263 500MHz, 2,500V/μs EL8108 300MHz, I _{OUT} = 450mA	High Gain Bandwidth Low Noise Single Channel EL5131 900MHz, 1.9nV/VHz ISL55190 800MHz, 1.2nV/VHz Dual Channel ISL55290 800MHz, 1.2nV/VHz EL5236 250MHz, 1.5nV/VHz Min Gain 2 EL5237 250MHz, 1.5nV/VHz Min Gain 2, EN	Triple Channel EL5370 100MHz, 1,200V/μs Gain = 2, EN EL5371 250MHz, 700V/μs, EN EL5373 450MHz, 1,100V/μs Gain = 2, EN EL5374 550MHz, 850V/μs, EN EL5378 700MHz, 1,000V/μs, EN	Triple Channel EL5306 1.5mA/ch supply current 350MHz, 4,500V/μs, ±1, 2 (Fixed Gain), EN EL5308 3.5mA/ch supply current 450MHz, 4,500V/μs, ±1, 2 (Fixed Gain), EN
Quad Channel EL8401 200MHz, 200V/μs EL8403 500MHz, 600V/μs	Triple Channel EL5302 400MHz, 3,500V/μs, EN EL5304 700MHz, 4,000V/μs, EN	Triple Channel EL5360 200MHz, 1,700V/μs, EN EL5362 500MHz, 2,500V/μs, EN EL5364 600MHz, 4,200V/μs, EN	Fully Differential Amplifier Single Channel ISL55210 2.2GHz, 0.85nV/VHz Min Gain 4 ISL55211 1.2GHz, 0.85nV/VHz Gains 2, 4, 5	Differential Line Receivers Single Channel EL5172 250MHz, 800V/μs, EN EL5175 550MHz, 900V/μs, EN Triple Channel EL5372 250MHz, 800V/μs, EN EL5375 550MHz, 900V/μs, EN	RF Gain Block/Amps Single Channel ISL55012 Z _{in} = 75Ω, Z _{out} = 50Ω, Gain = 18dB, NF = 4.7dB, I _s = 63.5mA ISL55014 Z _{in} = 50Ω, Z _{out} = 50Ω, Gain = 17.2dB, NF = 4.3dB, I _s = 63mA ISL55015 Z _{in} = 75Ω, Z _{out} = 50Ω, Gain = 13.5dB, NF = 4.8dB, I _s = 63.5mA
		Quad Channel EL5462 500MHz, 4,000V/μs			Differential Single Channel ISL55016 Z _{in} = 75Ω, Z _{out} = 100Ω NF = 5.4dB, I _s = 104mA

*EN = Enable feature

iSimTM
iSim Active Filter Designer
 Advanced design tool for
 creating complex solutions in 4
 easy steps.
www.intersil.com/isim

World's Best SFDR at Lowest Power ADC Driver



The ISL55210 is a very wide band, voltage feedback, fully differential amplifier (FDA) intended for high dynamic range ADC input interface applications. This voltage feedback FDA design includes an independent output common mode voltage control.

Intended for very high dynamic range ADC interface applications at the lowest quiescent power (115mW), the ISL55210 offers a 4.0GHz Gain Bandwidth Product with a very low input noise of 0.85nV/√(Hz). In a balanced differential I/O configuration, with 2V_{p-p} output into a 200Ω load configured for a gain of 15dB, the IM3 terms are <-109dBc through 110MHz. With a minimum operating gain of 2V/V (6dB), the ISL55210 supports a wide range of higher gains with minimal BW or SFDR degradation. Its ultra high differential slew rate of 5,600V/μs ensures clean large signal SFDR performance or a fast settling step response.

Key Features

- Gain Bandwidth Product..... 4.0GHzZ
- Input Voltage Noise.....0.85nV/√(Hz)
- Differential Slew Rate 5,600V/μs
- 2V_{p-p}, 2-tone IM3 (200Ω) 100MHz -109dBc
- Supply Voltage Range3.0V to 4.2V
- Quiescent Power (3.3V supply)..... 115mW

Applications

- Low Power, High Dynamic Range ADC Interface
- Differential Mixer Output Amplifier
- SAW Filter Pre/Post Driver
- Differential Comms-DAC Output Driver

Ultra-low Distortion

Suitable for driving high speed ADCs in 1st and higher Nyquist zone applications

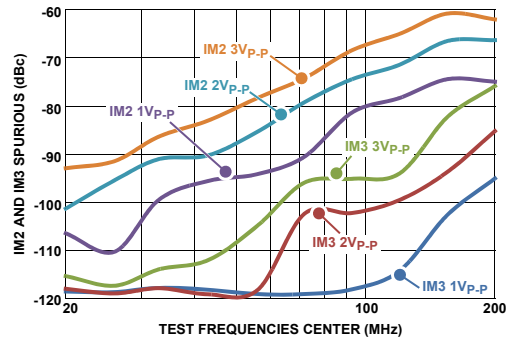

World Best SFDR at Lowest Power

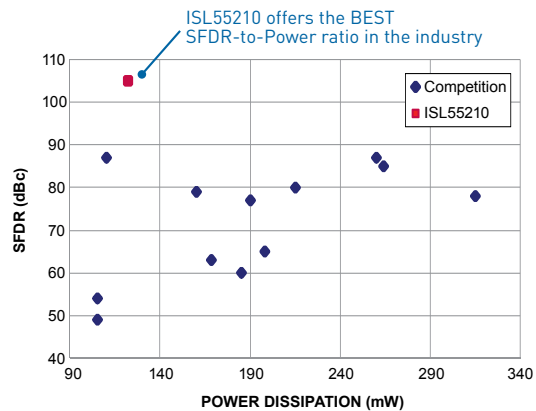

Typical Application Circuit

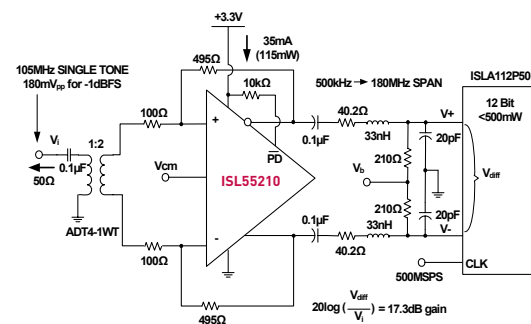

Device	# of Channels	Topology	V _S Min (V)	V _S Max (V)	BW (MHz)	G _{MIN} (V/V)	Slew Rate (V/μsec)	Noise (nV/√Hz)	I _S Max (mA)	I _{OUT} (mA)	V _{OS} Max (mV)	I _B Max (μA)	RR In	RR Out	Headroom (V)	Shutdown
ISL55210	1	FDA	3	4.2	2200	4	5600	0.85	38.5	30	1.2	90	No	No	1	Yes
ISL55211	1	FDA	3	4.2	1400	2	5600	0.85	38.5	30	1.2	91	No	No	1	Yes

Precision Op Amps

Ultra Precision

Low Voltage (5V)

Single	Dual	Quad
ISL28133	ISL28233	ISL28433

- Low Offset - 6 μ V max
- Micro-power - 25 μ A max
- Low Drift - 50nV/°C
- Chopper Stabilized

ISL28134

- Low Offset - 2.5 μ V max
- Low Drift - 15nV/°C max
- Low Noise - 250nVpp
- Chopper Stabilized

High Voltage (40V)

Single	Dual	Quad
ISL28117B	ISL28217B	ISL28417

- Low Offset - 50 μ V max
- Low Power - 0.53 μ A max

ISL28127 ISL28227

- Low Offset - 70 μ V max
- Low Noise - 2.5nV/VHz

ISL28107 ISL28207 ISL28407

- Low Offset - 75 μ V max
- Low Power - 290 μ A max

ISL28118 ISL28218

- Low Offset - 230 μ V max
- Single Supply - RRO

ISL28110 ISL28210

- Low Offset - 300 μ V max
- Low Ib - 2pA max

ISL28108 ISL28208 ISL28408

- Low Offset - 230 μ V max
- Single Supply - RRO
- Low Power - 250 μ A

ISL28177

- Low Offset - 150 μ V
- Low Cost

Low Noise

Low Voltage (5V)

Single	Dual
ISL28190	ISL28290

- Low Noise - 1nV/VHz
- Low THD+N

ISL28191 ISL28291

- Low Noise - 1.7nV/VHz
- Low THD+N

ISL28134

- Low Noise - 250nVpp (0.1 to 10Hz)

High Voltage (40V)

Single	Dual
ISL28127	ISL28227

- Low Noise - 2.5nV/VHz
- Low Offset - 70 μ V max

ISL28118 ISL28218

- Low Noise - 5.6nV/VHz
- Low Offset - 230 μ V max
- Single Supply - RRO

ISL28110 ISL28210

- Low Noise - 6nV/VHz
- Low Offset - 300 μ V max
- Low Ib - 2pA max

Low Power

Low Voltage (5V)

Single	Dual	Quad
ISL28194		

- Micro-Power - 450nA max

ISL28133 ISL28233 ISL28433

- Micro-power - 25 μ A max
- Low Offset - 6 μ V max
- Low Drift - 50nV/°C
- Chopper Stabilized

High Voltage (40V)

Single	Dual	Quad
ISL28108	ISL28208	ISL28408

- Low Offset - 230 μ V max
- Low Power - 250 μ V max

ISL28107 ISL28207 ISL28407

- Low Offset - 75 μ V max
- Low Power - 290 μ A max

ISL28117B ISL28217B ISL28417B

- Low Offset - 50 μ V max
- Low Power - 0.53 μ A max

Low Input Bias Current

Low Voltage (5V)

Single	Dual	Quad
ISL28113	ISL28213	ISL28413

- Low Ib - 20pA max

ISL28114 ISL28214 ISL28414

- Low Ib - 20pA max

ISL28158 ISL28258

- Low Ib - 30pA max

High Voltage (40V)

Single	Dual	Quad
ISL28110	ISL28210	

- Low Noise - 6nV/VHz
- Low Offset - 300 μ V max
- Low Ib - 2pA max

ISL28107 ISL28207 ISL28407

- Low Offset - 75 μ V max
- Low Power - 290 μ A max
- Low Ib - 300pA max



iSim Active Filter Designer
Advanced design tool for creating complex solutions in 4 easy steps.
www.intersil.com/isim

Other Special Categories of Performance

Precision Amps with Low Distortion

ISL28x27	0.00005% THD+N, 10MHz, 40V
ISL28x90	0.000017% THD+N, 170MHz, 5V
ISL28x91	0.000017% THD+N, 61MHz, 5V

Precision Amps with Low Current Noise (1kHz)

ISL28x33	70fA/ \sqrt Hz, 300pA I _{BIAS} , low V _{OS} drift, 5V
ISL28x07	20fA/ \sqrt Hz, 300pA I _{BIAS} , 300 μ A ISY, 40V
ISL28x88	9fA/ \sqrt Hz, 30pA I _{BIAS} , 78 μ A ISY, 5V
ISL28x10	9fA/ \sqrt Hz, 2pA I _{BIAS} , 50V
ISL28x13	5fA/ \sqrt Hz, 20pA I _{BIAS} , 5V
ISL28x14	8fA/ \sqrt Hz, 20pA I _{BIAS} , 5V
ISL28x48	16fA/ \sqrt Hz, 30pA I _{BIAS} , 5V

Precision Amps with Higher Bandwidth and Speed

ISL28x27	10MHz, 3.6V/ μ s, 70 μ V V _{OS} , low noise 40V
ISL28x34	3.5MHz, 1.5V/ μ V, 2.5 μ V, low noise 5V, Chopper Stabilized
ISL28x18	4MHz, 1.2V/ μ s, 230 μ V, 40V single supply
ISL28x36	5MHz, 1.9V/ μ s, 150 μ V V _{OS} , low noise 5V
ISL28x38	4.5MHz, 4.8V/ μ s, 300 μ V V _{OS} , 5V
ISL28x10	40V JFET-input 2pA, 10MHz, 20V/ μ s, low noise precision
ISL28x90	170MHz, 50V/ μ s, 700 μ V V _{OS} , low noise 5V
ISL28x91	61MHz, 17V/ μ s, 700 μ V V _{OS} , low noise 5V

Precision Amps in Tiny Packages

ISL28194, ISL28x90, ISL28x91, ISL28x33	μ TDFN package
--	--------------------

Precision Amps with Shutdown Capability for Low Power

ISL28194	Nano-power
EL8176, ISL28x30, ISL28x33, ISL28x36, ISL28x38, ISL28x91, ISL28x90, ISL28x48	Micro-power

General Purpose/Cost Sensitive Amps

ISL28x30 ISL28x13 ISL28x14 ISL28x77, ISL28325/345
--

x = 1 - Single, 2 - Dual, 4 - Quad

► Low Voltage Ultra Precision



Chopper-stabilized Amplifiers : ISL28x33, ISL28x34

Zero Drift Amplifiers (Low Voltage Precision Op Amps)

Chopper-stabilized amplifiers (Zero Drift Amplifiers) offer one of the best solutions, for the lowest offset voltage and drift. These amplifiers achieve high DC precision through a continuously running calibration mechanism that is implemented on-chip.

Features and Benefits

- Low Drift / Reduced Offset Voltage Over Temperature (typically $0.5\text{nV}/^\circ\text{C}$) [Figure 1]
- Low Drift /Reduced Offset Voltage Over Time [Figure 2]
- Low Offset Voltage / Reduced Offset Voltage (typically $1\mu\text{V}$) [Figure 3]
- Low Offset Voltage Over the Common Mode Range and Power Supply (CMRR & PSRR typically > 125dB) [Figure 4]
- Eliminates or No 1/f Noise [Figure 5]
- Very High Open Loop Gain
- Precision Signal Amplifications

Precision Amps by DC Offset and Drift Over Temperature

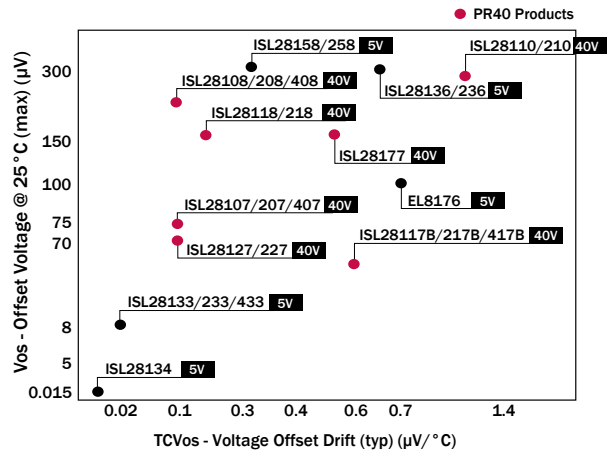

Low Drift Over Temperature

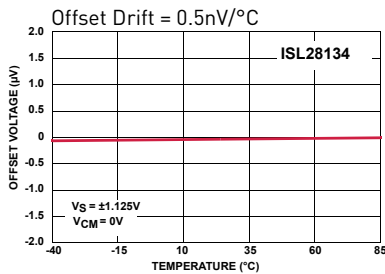

Figure 1. V_{OS} vs Temperature

Low Noise

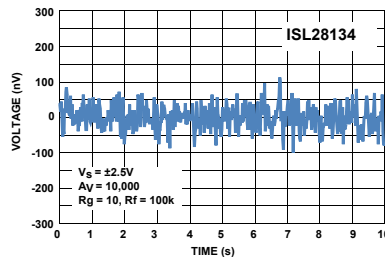

Figure 2. Input Noise Voltage 0.1Hz to 10Hz

Low Offset Voltage

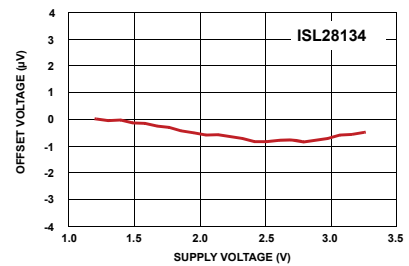

Figure 3. V_{OS} vs Supply Voltage

High CMRR/PSRR

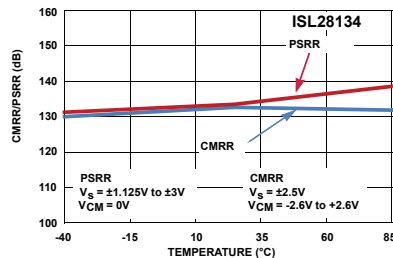

Figure 4. CMRR vs Temperature

No 1/f Noise

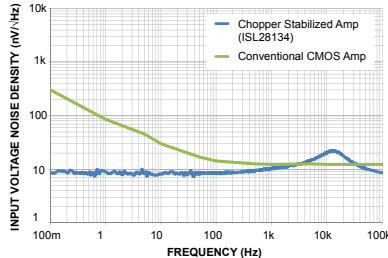

Figure 5. 5V CMOS ISL28134 vs CMOS Amp Noise Voltage Density Comparison

Part Number			Supply Voltage (V)		Rail-To-Rail		Vos Max @ 25°C	TCvos Max	Ib Max @ 25°C	CMRR min @ 25°C	PSRR min @ 25°C	Is Max @ 25°C	GBW	Slew Rate	Noise 0.1 to 10Hz	Voltage Noise @ 1kHz	Package		
Single	Dual	Quad	Min	Max	In	Out	μV	$\mu\text{V}/^\circ\text{C}$	nA	dB	dB	mA	MHz	V/ μs	μVpp	nV/ $\sqrt{\text{Hz}}$	Single	Dual	Quad
ISL28133*	ISL28233	ISL28433	1.65	5.5	Yes	Yes	6	0.05	0.18	118	110	0.025	0.4	0.2	1	65	SC70, SOT23, TDFN	MSOP, SOIC, TDFN	SOIC, TSSOP
ISL28134			2.25	6	Yes	Yes	0.0025	0.0005	0.3	120	120	0.900	3.5	1.5	0.25	10	SOIC, SOT23		

*Some specifications will differ, please check data sheet for actual parameters and/or conditions

► High Voltage Ultra Precision

Precision High Voltage Op Amps were Developed on Intersil's New PR40 Process

Precision high voltage op amps were developed on Intersil's new PR40 process. PR40 is a new precision process that enables Intersil to develop competitive precision high voltage amplifiers. Key features of the new process are full DI, complementary bipolar, low noise, well-matched Super-beta transistors, P-channel JFET, high breakdown voltage (>44V), high density capacitors, Thin Film resistors, fuse-link trim cells, and high ESD cells. (Figure 1)

Features and benefits

- Full dielectric isolation (DI) and high ESD cells (>4kV ESD HBM) provide highly robust inputs compared to older process amplifiers.
- Thin film resistors and fuse-link trim cells offer very low offset voltages (Figure 2)

PR40 Process

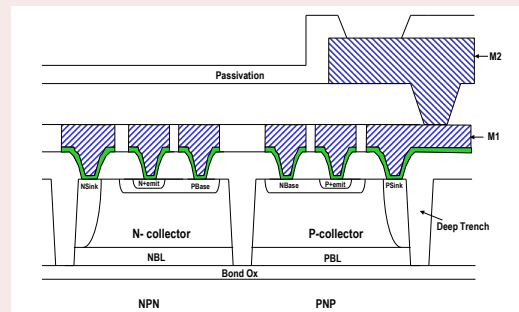

Figure 1 Cross-section drawing of PR40 NPN and PNP devices

Low Offset Voltage

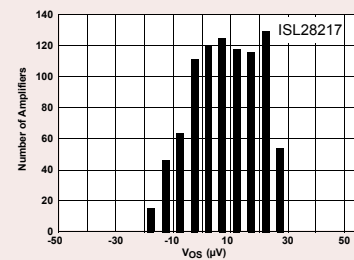

Figure 2



New Wave of Amplifiers From PR40-Precision-SOI Advance Bipolar Process

Intersil's ISL28127 is a high voltage precision op amp, delivering low frequency noise, low distortion, ultra low offset and low drift offset.

Features

- Very Low Voltage Noise.....2.5nV/√Hz
- Low Input Offset.....70µV, Max.
- Superb Offset Drift0.5µV/°C, Max.
- Wide Supply Range.....4.5V to 40V
- Gain-bandwidth Product.....10MHz Unity Gain Stable
- Outstanding ESD Performance
 - Human Body Model: 4.0kV

40V Low Noise, Precision Bipolar Op Amp: ISL28127

20% Lower Noise at 30% Less Power Than Competition

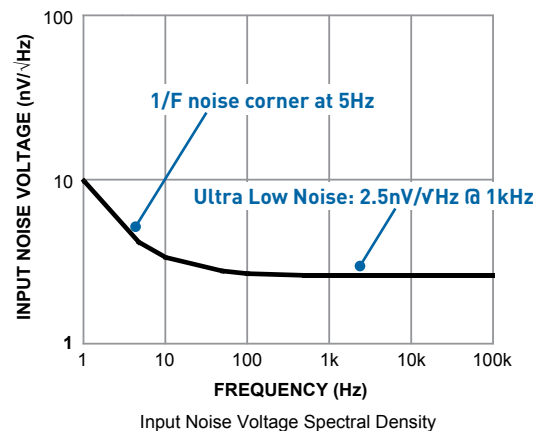

Part Number			Supply Voltage (V)		Rail-To-Rail		Vos Max @ 25°C	TCVos Typ	Ib Max @ 25°C	CMRR min @ 25°C	PSRR min @ 25°C	Av min @ 25°C	Is Max @ 25°C	GBW	Slew Rate	Noise 0.1 to 10Hz	Voltage Noise @ 1kHz	Current Noise @ 1kHz
Single	Dual	Quad	Min	Max	In	Out	µV	µV/°C	nA	dB	dB	dB	mA	MHz	V/µs	µVpp	nV/√Hz	fA/√Hz
ISL28117B	ISL28217B	ISL28417B	4.5	40	No	No	50	0.14	1	120	120	129.5	0.53	1.5	0.5	0.25	8	100
ISL28127	ISL28227		4.5	40	No	No	70	0.1	10	115	115	120	2.8	10	3.6	0.085	2.5	400
ISL28107	ISL28207	ISL28407	4.5	40	No	No	75	0.1	0.3	115	115	129.5	0.29	1	0.32	0.34	13	53
ISL28117C	ISL28217C	ISL28417C	4.5	40	No	No	100	0.14	1	120	120	129.5	0.53	1.5	0.5	0.25	8	100
ISL28118	ISL28218		3	40	Single Supply	Yes	230	0.3	575	103	109	124.7	1.1	4	1.2	0.3	5.6	355
ISL28177			4.5	40	No	No	150	0.5	1	120	115	120	1.4	0.6	0.2	0.38	9.5	87
ISL28108	ISL28208	ISL28408	3	40	Single Supply	Yes	250	0.1	43	105	110	117	0.25	1.2	0.45	0.58	15.8	80
ISL28110	ISL28210		9	40	No	No	300	1	0.002	88	102	104	2.9	12.5	23	0.6	6	9
	ISL28325	ISL28345	5	40	No	No	1000	4	5	80	80	100	0.7	1.2	0.4	0.4	9	100

► Low Noise

Low Noise Precision Op Amps

Precision Amps by Lowest Noise

It is critical to have an amplifier having very low background noise when the desired signal is weak or absent. Intersil's high voltage low noise op amps are developed on dielectrically isolated PR40 to offer low noise and improved THD.

Key Specifications

- Low Frequency Noise (0.1 to 10Hz)
- Wideband Voltage Noise (@ 1kHz)
- Wideband Current Noise (@ 1kHz)
- THD+N (in dB or %)

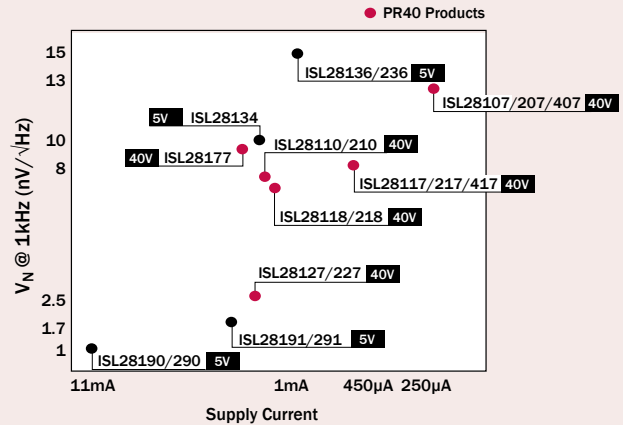

Part Number		Supply Voltage (V)		Rail-To-Rail		Vos Max @ 25°C	Vos Max Temp	TCVos Typ	Ib Max @ 25°C	CMRR min @ 25°C	PSRR min @ 25°C	Av min @ 25°C	Is Max @ 25°C	GBW	Slew Rate	Noise 0.1 to 10Hz	Voltage Noise @ 1kHz	Current Noise @ 1kHz
Single	Dual	Min	Max	In	Out	µV	µV	µV/°C	nA	dB	dB	dB	mA	MHz	V/µs	µVpp	nV/√Hz	fA/√Hz
ISL28190	ISL28290	3	5.5	Single Supply	Yes	700	900	1.9	16,000	78	74	94	11	170	50		1	2,100
ISL28191	ISL28291	3	5.5	Single Supply	Yes	630	840	3.1	6,000	78	74	99	3.5	61	17		1.7	1,800
ISL28127	ISL28227	4.5	40	No	No	70	120	0.1	10	115	115	120	2.8	10	3.6	0.085	2.5	400
ISL28118	ISL28218	3	40	Single Supply	Yes	230	290	0.3	575	103	109	124.7	1.1	4	1.2	0.300	5.6	355
ISL28110	ISL28210	9	40	No	No	300	1300	1	0.002	88	102	104	2.9	12.5	23	0.600	6	9
ISL28117B	ISL28217B	4.5	40	No	No	50	110	0.14	1	120	120	129.5	0.53	1.5	0.5	0.250	8	100
ISL28117C	ISL28217C	4.5	40	No	No	100	190	0.14	1	120	120	129.5	0.53	1.5	0.5	0.250	8	100
ISL28134		2.25	6	Yes	Yes	2.5	3.4	0.0005	0.3	120	120	174	0.900	3.5	1.5	0.25	10	200
ISL28177		4.5	40	No	No	150	350	0.5	1	120	115	120	1.4	0.6	0.2	0.38	9.5	87
ISL28107	ISL28207	4.5	40	No	No	75	140	0.1	0.3	115	115	129.5	0.29	1	0.32	0.340	13	53

► LowPower

Low Power Precision Op Amps

Nano-Power

Intersil offers wide range of low power amplifiers from lowest 'nano-power' to 'high performance' amplifiers depending on the application need.

Key Specifications

- Quiescent or Supply Current (I_s)
- Enable / Disable (Turn off amplifier to save power)
- Low Operating Voltages

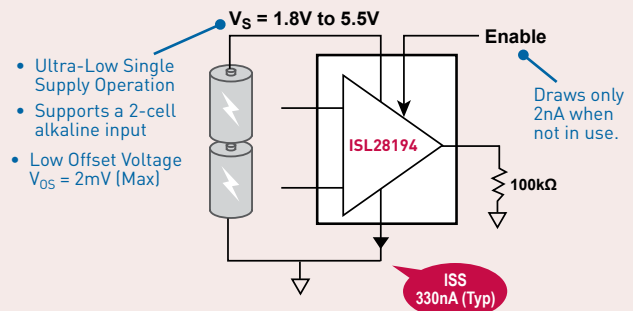

Nano-power

Part Number			Supply Voltage (V)		Rail-To-Rail		Vos Max @ 25°C	TCVos Typ	Ib Max @ 25°C	CMRR min @ 25°C	PSRR min @ 25°C	Av min @ 25°C	Is Max @ 25°C	GBW	Slew Rate	Enable
Single	Dual	Quad	Min	Max	In	Out	mV	µV/°C	nA	dB	dB	dB	µA	MHz	V/µs	
ISL28194			1.8	5.5	Yes	Yes	2	1.5	0.08	70	70	97.5	0.45	0.0035	0.0012	Yes
ISL28130*	ISL28230*	ISL28430*	1.65	5.5	Yes	Yes	0.04	0.02	0.25	110	105	150	25	0.4	0.2	No
ISL28133*	ISL28233*	ISL28433*	1.65	5.5	Yes	Yes	0.006	0.05	0.18	118	110	175	25	0.4	0.2	No
ISL28158	ISL28258		2.4	5.5	Yes	Yes	0.3	0.3	0.03	75	80	100	43	0.2	0.1	Yes
EL8176			2.4	5.5	Yes	Yes	0.1	2.4	2	90	90	106	75	0.4	0.13	Yes
ISL28176	ISL28276	ISL28476	2.4	5.5	Yes	Yes	0.1	0.5	2	90	90	106	75	0.4	0.13	No
	ISL28288 (EN)	ISL28488	2.4	5.5	Yes	Yes	1.5	0.9	0.03	80	85	106	78	0.3	0.14	

* Some specifications will differ, please check data sheet for actual parameters and/or conditions

► Low Input Bias Current

Precision Low Input Bias Current Operational Amplifier

In an ideal amplifier, there should be no current flow into the input terminals of an op amp. In general, there are always two input bias currents, I_{B+} and I_{B-} .

- I_B can vary from few fA to many μA , depending on the input device.
- Some input structures have well-matched I_B .
- FET op amp's I_B doubles with every 10°C rise in temperature.
- Some structures have I_B which may flow in either direction.
 - Usually CMOS/JFET amplifiers.
- Intersil's new JFET amplifier (ISL28210) employs bias cancelling structure to offer low bias current over temperatures.
- Low I_B amplifiers are ideal for photodiode, high impedance type applications.

Typical Application

ISL28210 is ideal for Flow Sensors and other high impedance applications.

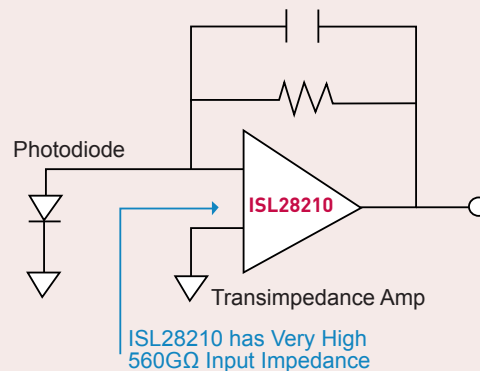

JFET Input

Part Number			Supply Voltage (V)		Rail-To-Rail		Vos Max @ 25°C	TCVos Typ	Ib Max @ 25°C	CMRR min @ 25°C	PSRR min @ 25°C	Is Max @ 25°C	GBW	Slew Rate	Noise 0.1 to 10Hz	Voltage Noise @ 1kHz
Single	Dual	Quad	Min	Max	In	Out	mV	$\mu V/^\circ C$	nA	dB	dB	mA	MHz	V/ μs	μV_{pp}	nV/ \sqrt{Hz}
ISL28110	ISL28210		9	40	No	No	0.300	1	0.002	88	102	2.9	12.5	23	0.6	6
ISL28113*	ISL28213*	ISL28413*	1.8	5.5	Yes	Yes	5	2	0.02	72	71	0.13	2	1	14	55
ISL28114*	ISL28214*	ISL28414*	1.8	5.5	Yes	Yes	5	2	0.02	72	71	0.36	5	2.5	12	40
ISL28158	ISL28258		2.4	5.5	Yes	Yes	0.3	0.3	0.03	75	80	0.043	0.2	0.1	1.4	64
	ISL28288	ISL28488	2.4	5.5	Yes	Yes	1.5	0.9	0.03	80	85	0.156	0.3	0.14	3	48
ISL28148	ISL28248		2.4	5.5	Yes	Yes	1.8	0.03	0.03	75	80	1.25	4.5	4	2	28
ISL28194*			1.8	5.5	Yes	Yes	2	1.5	0.08	70	70	0.00045	0.0035	0.0012	10	265
ISL28133*	ISL28233	ISL28433	1.65	5.5	Yes	Yes	0.006	0.05	0.18	118	110	0.025	0.4	0.2	1	65
ISL28130	ISL28230	ISL28430	1.65	5.5	Yes	Yes	0.04	0.02	0.25	110	105	0.025	0.4	0.2	1.1	65
ISL28107	ISL28207	ISL28407	4.5	40	No	No	0.075	0.1	0.3	115	115	0.29	1	0.32	0.34	13
ISL28134			2.25	6	Yes	Yes	0.0025	0.0005	0.3	120	120	0.900	3.5	1.5	0.25	10

* Some specifications will differ, please check data sheet for actual parameters and/or conditions

► Current Sense Amplifier



28V Micro-power, Precision High Side and Low Side Current Sense Amplifiers

Key Features

- Supply Independent of Input
 - 2.7V to 28V Supply
 - 0V to 28V V_{CM}
- Max. 250 μV Input V_{OS}
- Gain Accuracy Max:
 - 0.5% 25°C
- Four Gain Options
 - 20V/V, 50V/V, 100V/V, & ADJ
- -40°C to +125°C Operation

Applications

- Low Ohmic Shunt Sense
- Battery Management
- High-precision Voltage and Current Measurement
- Power Management in Communications, Networking, Industrial
- Computing and Display Power Management
- Alternative Energy (wind, power, solar)

Current Sense Amplifiers: ISL28005, ISL28006

Only 50 μA Current Consumption

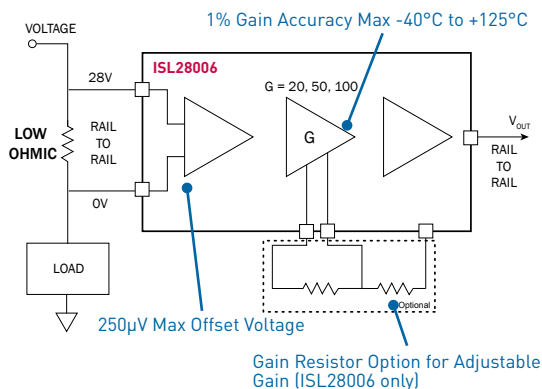

Part Number	Supply Voltage Range V	Input Common Mode Range V	Vos Max @ 25°C μV	Vos Max Temp μV	CMRR min Temp dB	PSRR min Temp dB	Gain Range V/V	Gain Accuracy @ 25°C %	Gain Accuracy Temp %	Is Max @ 25°C μA	Is Max Temp μA	GBW kHz	Temp Range °C	Package
ISL28005	2.7 to 28	0 to 28	500	500	105	90	20, 50, 100	2	3	59	59	180	-40 to 125	SOT23
ISL28006	2.7 to 28	0 to 28	250	300	105	90	20, 50, 100, Adj (20-100)	0.7	1	62	62	180	-40 to 125	SOT23

Precision Instrumentation Amplifiers

► High Voltage Instrumentation Amplifier

Instrumentation Amplifiers: ISL28617

40V Precision Instrumentation Amplifier with Differential ADC Driver

The ISL28617 is a high performance, differential input, differential output instrumentation amplifier designed for precision analog to digital applications. It can operate over a supply range of 8V ($\pm 4V$) to 40V ($\pm 20V$) and features a differential input voltage range up to $\pm 34V$. The output stage has rail-to-rail output drive capability optimized for differential ADC driver applications.

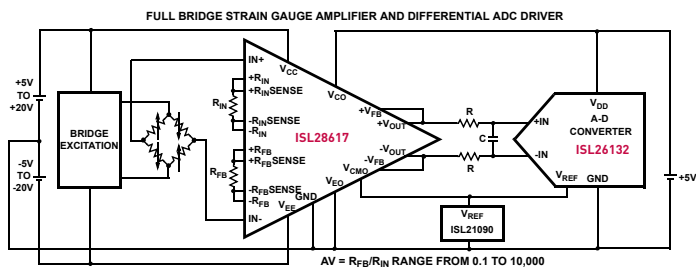

Excellent CMRR

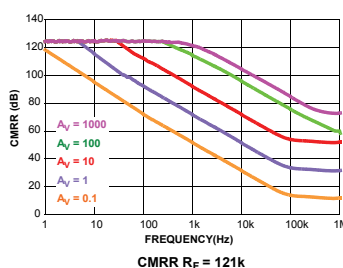

Very Low Input Noise

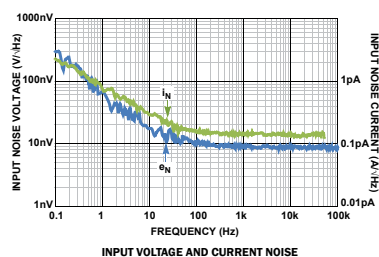

Part Number	Supply Voltage (V)		Rail-To-Rail		Min Gain (V/V)	Vos Max @ 25°C (mV)	TCVos Typ ($\mu V/^\circ C$)	Ib Max @ 25°C (nA)	CMRR min @ 25°C (dB)	PSRR min @ 25°C (dB)	Gain Error Typ (%)	Isc Typ (mA)	Is Max @ 25°C (mA)	-3dB BW (MHz)	Slew Rate (V/ μs)	Noise 0.1 to 10Hz (μV_{pp})	Voltage Noise @ 1kHz (nV/ \sqrt{Hz})	Current Noise @ 1kHz (fA/ \sqrt{Hz})	Temp Range (°C)
	Min	Max	In	Out															
ISL28617	8	40	No	Yes	0.1	0.1	0.5	1	130	123	0.0005	45	4.8	4	4	0.085	8.6	150	-40 to 125

► Low Voltage, Low Power Instrumentation Amplifier

Instrumentation Amplifiers: EL817x, ISL2827x

Micro-power Instrumentation Amps

Key Features

- Extremely Low Supply Currents
 - <156 μA Max. Supply Current
- Single Supply 2.4V to 5.0V Operation
- Rail-to-rail Input and Output (RRIO)
 - Operate above and below the rails
 - Ground sensing option

Excellent CMRR

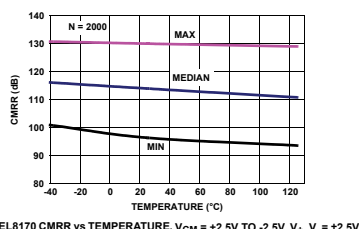

EL8170 CMRR vs TEMPERATURE, $V_{CM} = +2.5V$ TO $-2.5V$, V_+ , $V_- = \pm 2.5V$

Low Supply Current

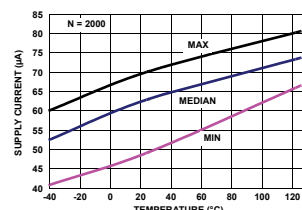

EL8170 SUPPLY CURRENT vs TEMPERATURE, V_+ , $V_- = \pm 2.5V$, $V_{IN} = 0V$

Part Number	Supply Voltage (V)		Rail-To-Rail		Min Gain (V/V)	Vos Max @ 25°C (mV)	TCVos Typ ($\mu V/^\circ C$)	Ib Max @ 25°C (nA)	CMRR min @ 25°C (dB)	PSRR min @ 25°C (dB)	Gain Error Typ (%)	Isc Typ (mA)	Is Max @ 25°C (μA)	-3dB BW @ Lowest Gain (kHz)	Slew Rate (V/ μs)	Noise 0.1 to 10Hz (μV_{pp})	Voltage Noise @ 1kHz (nV/ \sqrt{Hz})	Current Noise @ 1kHz (fA/ \sqrt{Hz})	Temp Range (°C)	Package	
	Min	Max	In	Out																8-SOIC	16-QSOP
EL8170	2.4	5	Yes	Yes	100	0.2	0.24	3	90	85	0.35	26	95	450	0.55	3.5	58	380	-40 to 125	Single	
EL8171	2.4	5	Yes	Yes	10	1.5	1.5	0.05	75	75	0.15	26	95	450	0.55	14	220	900	-40 to 125	Single	
EL8172	2.4	5	Yes	Yes	100	0.3	0.14	0.05	75	75	0.2	26	95	170	0.55	10	80	200	-40 to 125	Single	
EL8173	2.4	5	Yes	Yes	10	1	2.5	3	85	75	0.1	26	95	170	0.55	3.6	220	800	-40 to 125	Single	
ISL28270	2.4	5	Yes	Yes	100	0.15	0.7	2	90	90	0.5	29	156	0.24	0.5	3.5	60	370	-40 to 125		Dual
ISL28271	2.4	5	Yes	Yes	10	0.6	0.7	0.03	80	80	0.081	26	156	0.18	0.5	10	240	920	-40 to 125		Dual
ISL28272	2.4	5	Yes	Yes	100	0.5	0.7	0.03	80	80	0.19	26	156	0.1	0.5	6	78	200	-40 to 125		Dual
ISL28273	2.4	5	Yes	Yes	10	0.6	0.7	2.5	85	80	0.12	29	156	0.265	0.6	3.5	210	750	-40 to 125		Dual

Precision Voltage References

Ultra Precision	Ultra Low Power	Precision V_{REF} with Kelvin Sense	Low Cost	Adjustable/ Programmable	V_{REF} with Comparator
ISL21009 <ul style="list-style-type: none"> 3ppm/°C 4.5µVpp noise 5V - 16V input 180µA max 	ISL60002 <ul style="list-style-type: none"> 700nA max 	ISL21060 <ul style="list-style-type: none"> Stable for cap load drive 40µA max 10µVpp noise 	ISL60002 D-grade <ul style="list-style-type: none"> 900nA max 	ISL21400 <ul style="list-style-type: none"> Active temperature compensation 	ISL21440 <ul style="list-style-type: none"> 0.7µA max 1.182V voltage reference
ISL21090 <ul style="list-style-type: none"> 7ppm/°C 1µVpp noise 3.7V to 36V Input 	X60003 <ul style="list-style-type: none"> 900nA max 4.5V to 9V input 		ISL21080 <ul style="list-style-type: none"> 1.5µA max 		
ISL21060 <ul style="list-style-type: none"> 10ppm/°C 40µA max 10µVpp noise 	ISL21080 <ul style="list-style-type: none"> 1.5µA max 		ISL21070 <ul style="list-style-type: none"> 25µA max 		
	ISL21070 <ul style="list-style-type: none"> 25µA max 		ISL21010 <ul style="list-style-type: none"> 46µA typ 		
	ISL21060 <ul style="list-style-type: none"> 40µA max 10µVpp noise 		ISL21007 D-grade <ul style="list-style-type: none"> 150µA max 		
			ISL21009 D-grade <ul style="list-style-type: none"> 180µA max 		

Precision Voltage References

Device Number	Vout													Temp Co	Initial Acc	Temp Range	I _{sy} Max	V _{sy} Range	Noise Low Freq	Noise High Freq	Line Reg	Load Reg	I _{out} Source/Sink	Hyst	LTD	Pkg			
	0.6V	0.9V	1.024V	1.2V	1.25V	1.5V	1.8V	2.048V	2.5V	2.6V	3V	3.3V	4.096V														5V	7.5V	ppm/°C
ISL21009B					X				X				X	X		3	0.02	-40 to 125	180	3.5 to 16.5	4.5	2.2	150	100	7/7	50	50	SOIC-8	
ISL21007C				X			X	X		X						5	0.08	-40 to 125	150	2.7 to 5.5	4.5	2.2	200	100	7/7	50	100	SOIC-8	
ISL21009C				X				X				X	X			5	0.08	-40 to 125	180	3.5 to 16.5	4.5	2.2	150	100	7/7	50	50	SOIC-8	
ISL21090B				X				X					X	X		7	0.02	-40 to 125	1280	3.7 to 36	1	1.6	45	42.5	20/10	TBD	20	SOIC-8	
ISL21007D				X			X	X		X						10	0.08	-40 to 125	150	2.7 to 5.5	4.5	2.2	200	100	7/7	50	100	SOIC-8	
ISL21009D				X				X				X	X			10	0.08	-40 to 125	180	3.5 to 16.5	4.5	2.2	150	100	7/7	50	50	SOIC-8	
ISL21060B (EN)							X	X		X		X				10	0.04	-40 to 125	40	2.7 to 5.5	10	2.5	150	400	10/5	100	100	SOT23-6	
X60003B												X	X			10	0.02*	-40 to 85	0.9	4.5 to 9	30	NA	150	100	10/10	100	45	SOT23-3	
X60003C												X	X			20	0.05*	-40 to 85	0.9	4.5 to 9	30	NA	150	100	10/10	100	45	SOT23-3	
ISL60002B		X	X	X		X	X	X	X	X	X					20	0.04	-40 to 85	0.9	2.7 to 5.5	30	NA	350	250	7/7	100	50	SOT23-3	
ISL60002C		X	X	X		X	X	X	X	X	X					20	0.10	-40 to 85	0.9	2.7 to 5.5	30	NA	350	250	7/7	100	50	SOT23-3	
ISL60002D		X	X	X		X	X	X	X	X	X					20	0.49	-40 to 85	0.9	2.7 to 5.5	30	NA	350	250	7/7	100	50	SOT23-3	
X60003D												X	X			20	0.10*	-40 to 85	0.9	4.5 to 9	30	NA	150	100	10/10	100	45	SOT23-3	
ISL21060C (EN)							X	X		X		X				25	0.10	-40 to 125	40	2.7 to 5.5	10	2.5	150	400	10/5	100	100	SOT23-6	
ISL21070	X						X	X								30	0.20	-40 to 85	25	2.7 to 5.5	30	10	250	100	7/10	20	50	SOT23-3	
ISL21010		X		X	X		X	X		X	X	X				50	0.20	-40 to 125	80	2.7 to 5.5	58*	26*	130	110	25/1	100	50	SOT23-3	
ISL21080		X	X	X	X		X	X		X	X	X	X			50	0.30	-40 to 85	1.5	2.7 to 8	30	52	350	350	7/7	100	50	SOT23-3	
ISL21400	Programmable (0V to 1.2V) with Vout gain of 1, 2, or 4													*	2.00	-40 to 85	400	2.7 to 5.5	90	N/A	N/A	N/A	N/A	5/6	N/A	N/A	N/A	N/A	MSOP-8
ISL21440	1.182V ±0.5% with Comparator													*	0.50	-40 to 125	0.7	2 to 11	N/A	N/A	N/A	N/A	N/A	2/0.01	N/A	N/A	N/A	N/A	MSOP-8, TDFN-8

*See data sheet for conditions as there are slight difference in parameter/conditions.

Ultra Low Noise, Precision Voltage Reference

The ISL21090 is an ultra low noise, high DC accuracy precision voltage reference with wide input voltage range from 3.7V to 36V. The ISL21090 uses the new Intersil Advanced Bipolar technology to achieve sub $1\mu\text{V}_{\text{P-P}}$ (0.1Hz to 10Hz) noise with an initial voltage accuracy of 0.02%. The ISL21090 offers a 1.25V and 2.5V output voltage option with 7ppm/°C temperature coefficient and also provides excellent line and load regulation. The device is offered in an 8 Ld SOIC package. The ISL21090 is ideal for high-end instrumentation, data acquisition and processing applications requiring high DC precision where low noise performance is critical.

Key Features

- 2.5V Reference Output Voltage Option
- Initial Accuracy: $\pm 0.02\%$
- Output Voltage Noise: $1\mu\text{V}_{\text{P-P}}$ Typ (0.1Hz to 10Hz) (1.25V Option)
- Supply Current: 930 μA (Typ)
- Tempco: 7ppm/°C Max
- Output Current Capability: 20mA
- Line Regulation: 8ppm/V
- Load Regulation: 2.5ppm/mA
- Operating Temperature Range: -40°C to +125°C

Temperature Drift (Coefficient)

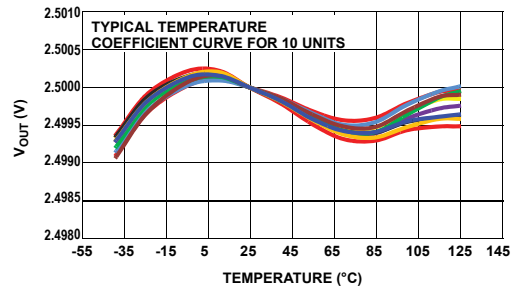

ISL21090 Typical Temperature Coefficient

Long Term Drift

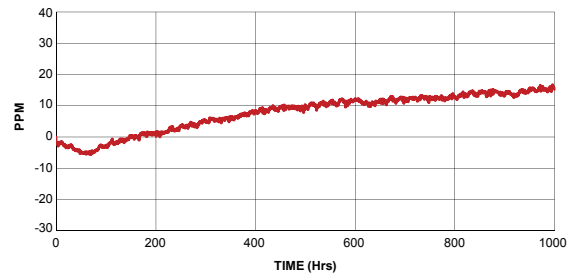

ISL21090 Long Term Drift Data (1000 Hrs)

Micropower Voltage Reference

The ISL21010 is a precision, low dropout micropower bandgap voltage reference in a space-saving SOT-23 package. It operates from a single 2.2V to 5.5V supply (minimum voltage is dependent on voltage option) and provides a $\pm 0.2\%$ accurate reference.

Key Features

- Reference Output Voltages: 1.024V, 1.25V, 1.5V, 2.048V, 2.5V, 3.0V, 3.3V, 4.096V
- Precision 0.2% Initial Accuracy
- Input Voltage Range:
 - ISL21010-10, -12, -15: 2.2V to 5.5V

Low Power Consumption

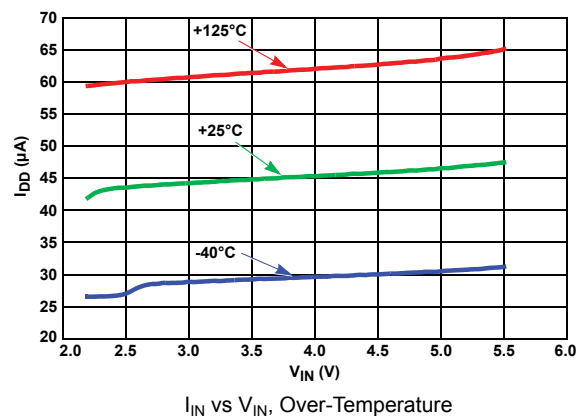

Power Management

▶ Integrated FET Switching Regulators

Single Output Boost Regulators: ISL97701

Boost Regulator with Integrated Schottky and Input Disconnect Switch



Key Features

- Up to 87% Efficiency
- 2.3V to 5.5V Input
- Up to 28V Output
- Integrated Boost Schottky Diode
- Input Voltage Disconnect Switch for Micro Power Shutdown
- Synchronization Input
- 10 Ld 3x3 DFN Package
- Pb-free (RoHS Compliant)

Up to 2.5W Output Power Delivered in a 3x3mm TDFN Package

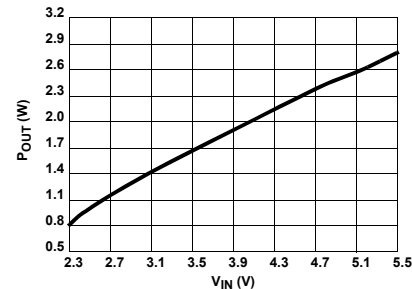

Recommended Maximum Output Power vs Input Voltage

A Simple Circuit to Generate Plus and Minus Supplies Using a Boost Regulator

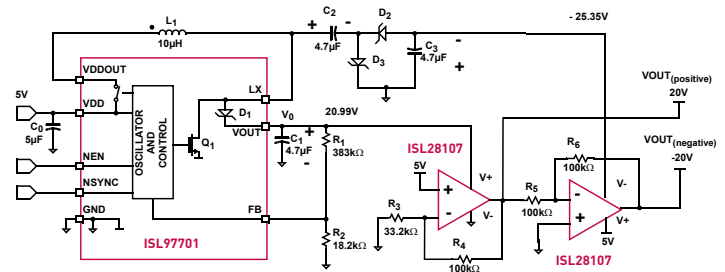

Reference Design to Generate a Positive and Negative Supply

Single Output Boost Regulators

Device	Device Description	V _{IN} Min (V)	V _{IN} Max (V)	V _{OUT} Min (V)	V _{OUT} Max (V)	Boost Current Limit (A)	Feedback Voltage & Accuracy	Features	Package
ISL97701	Boost Regulator with Integrated Schottky and Input Disconnect Switch	2.3	5.5	1.1 * V _{IN}	28	1.2	1.15V ±2.6%	Integrated Schottky, Low quiescent current and input disconnect switch for micropower shutdown	10 Ld DFN
ISL98012	Wide Input Voltage, Adjustable Frequency Boost Regulator	1.8	13.2	4.5	17	1.4	1.33V ±3%	Adjustable Soft-Start, 380kHz to 750kHz SF, Low battery detection	10 Ld MSOP
ISL97516	600kHz/1.2MHz PWM Step-Up Regulator	2.3	5.5	1.1 * V _{IN}	25	2	1.294V -1.7%, +1.15%	Adjustable Soft-Start, 600kHz/1.2MHz switching frequency	8 Ld MSOP
ISL97519	1% Output Accuracy PWM Step-Up Regulator with 1.294V Reference	2.3	5.5	1.1 * V _{IN}	25	2	1.294V ±1%	Adjustable Soft-Start, 620kHz/1.25MHz switching frequency	8 Ld MSOP
ISL97519A	1% Output Accuracy PWM Step-Up Regulator with 1.24V Reference	2.3	5.5	1.1 * V _{IN}	25	2	1.24V ±1%	Adjustable Soft-Start, 620kHz/1.25MHz switching frequency	8 Ld MSOP
ISL97656	High Current PWM Step-Up Regulator with 1.24V Reference	2.3	5.5	1.1 * V _{IN}	25	4	1.24V ±1.6%	Adjustable Soft-Start, 640kHz/1.22MHz switching frequency, high output current capability	10 Ld TDFN

Hot Plug Controllers



Single Rail Hot Plug Controller: ISL6186

Single USB Port Power Supply Controller



Key Features

- 2.5V to 5.5V Operating Range
- 45mΩ Integrated Power P-channel MOSFET Switches
- Variants for 1.5A, 3.0A and 3.6A Continuous Current Operation with Accurate Current Limiting
- Thermally Insensitive 12ms of Current Limiting Prior to Latch-Off or Turn-Off
- Output Discharges with Reverse Current Blocking when Disabled
- Latch-off or Auto Restart Variants
- 1μA Off-State Supply Current.
- Enable Polarity Variants
- Industry Standard Pin for Pin SOIC and Smaller DFN Packages

Pin-pin replacement for ISL6121

Typical Application

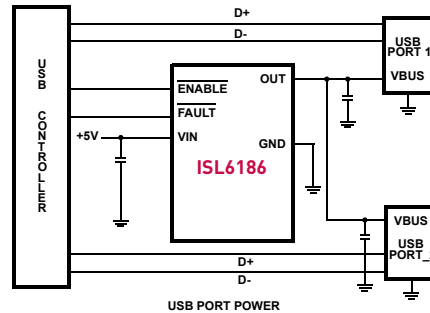

High Accuracy Current Limit And Trip

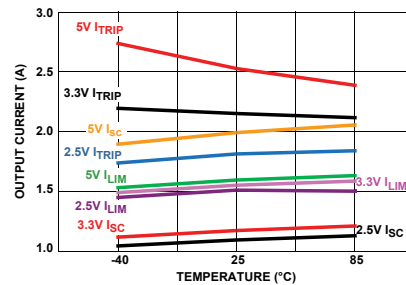

1.5A Continuous Current Characteristics

Better $R_{DS(on)}$ Performance

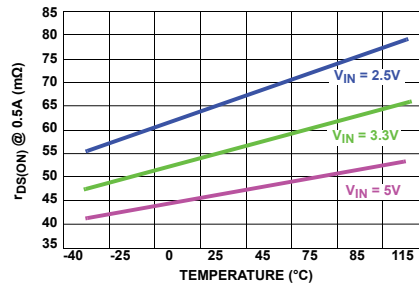

Switch On-Resistance at 0.5A

Single Rail Hot Plug Controllers

Device	Device Description	V_{BIAS} (V)	Controlled Voltages (V)	Regulation or Latch-Off for Overcurrent	$r_{DS(ON)}$ (mΩ)	UV/OV Feature	Reporting	Package
Internal FET								
ISL6121	Single Supply Integrated Current Limiting Controller	+2.5 to +5.5	+2.5 to +5.5	Current Regulation (2A)	50	UV Lockout	Fault-bar for OC Latch-Off	8 Ld SOIC
ISL6186	Single Supply Integrated Current Limiting Controller	+2.5 to +5.5	+2.5 to +5.5	Current Regulation Various Latch-Off or Retry	45	UV Lockout	Fault-bar for OC Latch-Off	8 Ld SOIC, 8 Ld DFN, 10 Ld DFN
External FET								
ISL6115/ISL6115A	Power Distribution Controllers	12	12	Current Regulation		UV Lockout	PGOOD + Fault Off	8 Ld SOIC
ISL6116	Power Distribution Controllers	12	5	Current Regulation		UV Lockout	PGOOD + Fault Off	8 Ld SOIC
ISL6117	Power Distribution Controllers	12	3.3	Current Regulation		UV Lockout	PGOOD + Fault Off	8 Ld SOIC
ISL6120	Power Distribution Controllers	12	2.5	Current Regulation		UV Lockout	PGOOD + Fault Off	8 Ld SOIC
ISL6140/ISL6150	Negative Voltage Hot Plug Controller	-10 to -80	-10 to -80	Latch-Off		UV/OV Lockout	PWRGD	8 Ld SOIC
ISL6141/ISL6142	Negative Voltage Hot Plug Controller	-20 to -80	-20 to -80	Current Regulation		UV/OV Lockout	PWRGD	8/14 Ld SOIC
ISL6151/ISL6152	Negative Voltage Hot Plug Controller	-20 to -80	-20 to -80	Current Regulation		UV/OV Lockout	PWRGD	8/14 Ld SOIC

▶ LDO / Linear Regulators

Low Voltage LDO: ISL80101A

Fast Transient Response 1A LDOs

Key Features

- 2.2V to 6V Input Voltage Range
- $\pm 2\%$ V_{ADJ} Accuracy Guaranteed Over Line, Load and $T_J = -40^\circ\text{C}$ to $+125^\circ\text{C}$
- Adjustable V_{OUT} and OCL
- Very Fast Transient Response
- Programmable Soft-Start
- Very Low 212mV Dropout Voltage at $V_{IN} = 4.5\text{V}$
- High Accuracy Current Limit Programmable Up to 1.75A
- Power-Good Output
- Over-Temperature Protection
- Small 10 Ld DFN Package

Applications

- Telecommunications and Networking
- Medical Equipment
- Instrumentation Systems
- USB Devices
- Gaming
- Routers and Switchers

Ultra Fast Transient Response

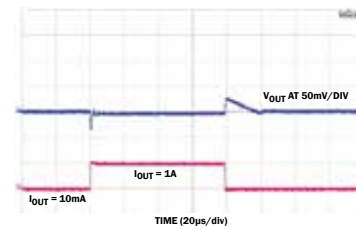

Load Transient Response

Best in Class Accuracy

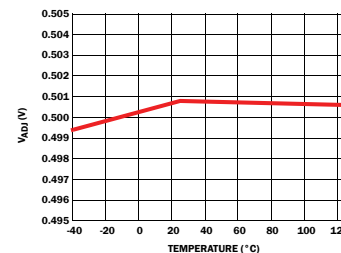

VADJ vs Temperature

Typical Application Circuit

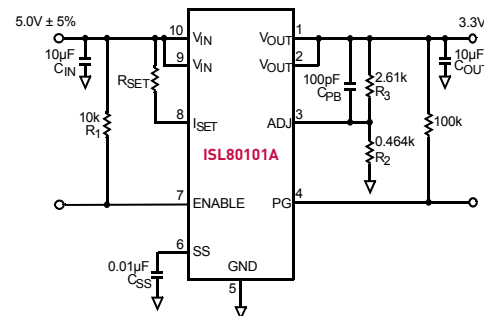

Low Voltage LDO/Linear Regulators

Device	Device Description	V_{IN} Range (V)	V_{OUT} Range (V)	O/P Volt Accuracy (%)	I_{OUT1} (max)	I_{OUT2} (max)	PSRR @ 1kHz (dB)	I_Q (μA)	Typical Drop-Out Voltage (mV)	Enable/Shutdown	Package
ISL9003A	Low Noise LDO with Low I_Q , High PSRR	2.3 to 6.5	1.5 to 3.3	± 1.8	150mA	N/A	90	29	200 @ 150mA	Y	5 Ld SC-70, 6 Ld μTDFN
ISL9008A	Low Noise LDO with Low I_Q , High PSRR	2.3 to 6.5	1.5 to 3.3	± 1.8	150mA	N/A	65	45	200 @ 150mA	Y	5 Ld SC-70, 6 Ld μTDFN
ISL9011A	Dual LDO with Low Noise, Low I_Q , and High PSRR	2.3 to 6.5	1.5 to 3.3	± 1.8	150mA	300mA	70	45	250 @ 300mA	Y	10 Ld DFN
ISL9012	Dual LDO with Low Noise, Low I_Q , and High PSRR	2.3 to 6.5	1.5 to 3.3	± 1.8	150mA	300mA	70	45	250 @ 300mA	Y	10 Ld DFN
ISL9016	150mA Dual LDO with Low Noise, High PSRR, and Low I_Q	1.8 to 6.5	1.2 to 3.3	± 1.8	150mA	150mA	80	49	250 @ 150mA	Y	6 Ld μTDFN
ISL9021A	250mA Single LDO with Low I_Q , Low Noise and High PSRR LDO	1.5 to 5.5	0.9 to 3.3	± 1.8	250mA	N/A	60	35	150 @ 250mA	Y	4 Ld WLCSP, 6 Ld μTDFN
ISL9000A*	Dual LDO with Low Noise, Very High PSRR, and Low I_Q	2.3 to 6.5	1.5 to 3.3	± 1.8	300mA	300mA	90	40	250 @ 300mA	Y	10 Ld DFN
ISL9001A	LDO with Low I_{SUPPLY} , High PSRR	2.3 to 6.5	1.5 to 3.3	± 1.8	300mA	N/A	90	25	250 @ 300mA	Y	8 Ld DFN
ISL9005A	LDO with Low I_{SUPPLY} , High PSRR	2.3 to 6.5	1.5 to 3.3	± 1.8	300mA	N/A	75	50	250 @ 300mA	Y	8 Ld DFN
ISL9014A	Dual LDO with Low Noise, Low I_Q , and High PSRR	2.3 to 6.5	1.5 to 3.3	± 1.8	300mA	300mA	70	45	250 @ 300mA	Y	10 Ld DFN
ISL9007	High Current LDO with Low I_Q and High PSRR	2.3 to 6.5	1.5 to 3.3	± 1.8	400mA	N/A	75	50	250 @ 400mA	Y	8 Ld MSOP
ISL80101	High Performance 1A LDO	2.2 to 6.0	0.8 to 5.0	± 1.8	1A	N/A	58	3mA	130 @ 1A	Y	10 Ld DFN

Low Voltage LDO/Linear Regulators (continued)

Device	Device Description	V _{IN} Range (V)	V _{OUT} Range (V)	O/P Volt Accuracy (%)	I _{OUT1} (max)	I _{OUT2} (max)	PSRR @ 1kHz (dB)	I _Q (μA)	Typical Drop-Out Voltage (mV)	Enable/Shutdown	Package
ISL80101-ADJ	High Performance 1A LDO	2.2 to 6.0	0.8 to 5.0	±1.8	1A	N/A	58	3mA	130 @ 1A	Y	10 Ld DFN
ISL80101A	High Performance 1A Linear Regulator with Programmable Current Limiting	2.2 to 6.0	0.8 to 5.0	±2.0	1A	N/A	48	3mA	212 @ 1A	Y	10 Ld DFN
ISL80121-5	1A Ultra Low Dropout Linear Regulator with Programmable Current Limiting	2.2 to 6.0	0.8 to 5.0	±1.8	1A	N/A	40	3mA	130 @ 1A	Y	10 Ld DFN
ISL80102	High Performance 2A Linear Regulator	2.2 to 6.0	0.8 to 5.0	±1.8	2A	N/A	55	7.5mA	81 @ 2A	Y	10 Ld DFN
ISL80103	High Performance 3A Linear Regulator	2.2 to 6.0	0.8 to 5.0	±1.8	3A	N/A	55	7.5mA	120 @ 3A	Y	10 Ld DFN

* Product available on military temperature plastic program (Visit <http://www.intersil.com/space/VID.asp> for further information).

High Voltage LDO: ISL6719

100V Linear Regulator Typical Application



Key Features

- Industry's First Dual 100V Linear Regulator
- Up to 100mA Output Current
- Enable Capability with Over-Current & Over-Temp Protection
- High Efficiency Bias for Both Isolated and Non-isolated Applications
- Small Form factor DFN Package

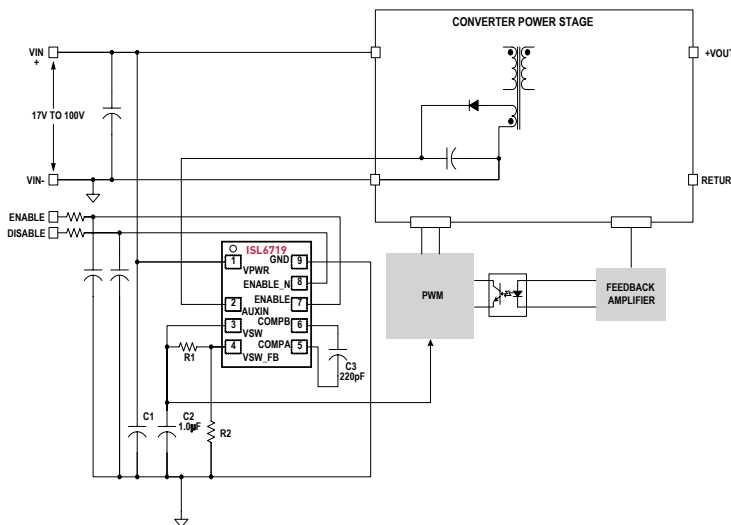

High Voltage LDO/Linear Regulators

Device	Device Description	V _{IN} (min) (V)	V _{IN} (max) (V)	V _{OUT} (min) (V)	V _{OUT} (max) (V)	I _{OUT} (max) (mA)	I _Q	Package
ICL7663S	CMOS Programmable Micropower Positive Voltage Regulator	1.6	16	1.3	16	40	12μA	8 Ld PDIP, 8 Ld SOIC
ISL6719	100V Linear Bias Supply	17	100	1.5	20	100	1.1mA	9 Ld DFN
ISL6720A	100V Triple Linear Bias Supply	17	100	0	20	125	1.2mA	11 Ld DFN
ISL78307	40V, Low Quiescent Current, 50mA Linear Regulator for Automotive Applications	6	40	2.5	12	50	18μA	8 Ld EPSON

Design Resources



iSim Active Filter Designer

Advanced design tool for creating complex solutions in 4 easy steps.

www.intersil.com/isim

1 Design Requirements Interview

Simply enter your design requirements, such as input and output voltage and current etc.

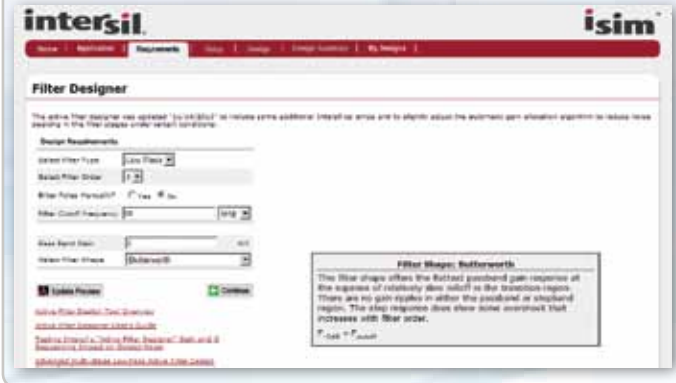

2 Design Configuration

iSim automatically calculates optimum loop compensation and calculates appropriate values for resistors and capacitors.

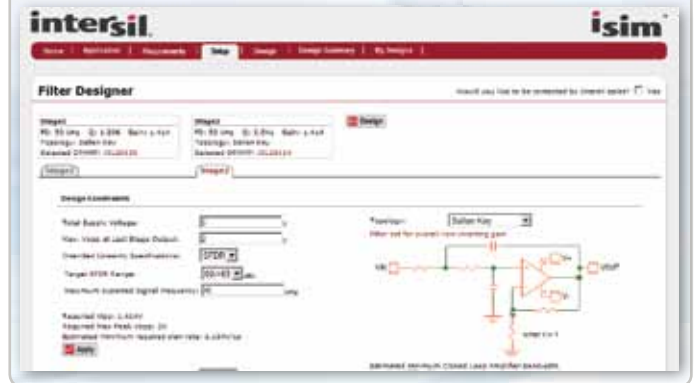

3 Design Verification by Remote Simulation

Your design is displayed in an Online Schematic, which allows you to test your application in a virtual test bed. iSim allows AC, transient analysis.

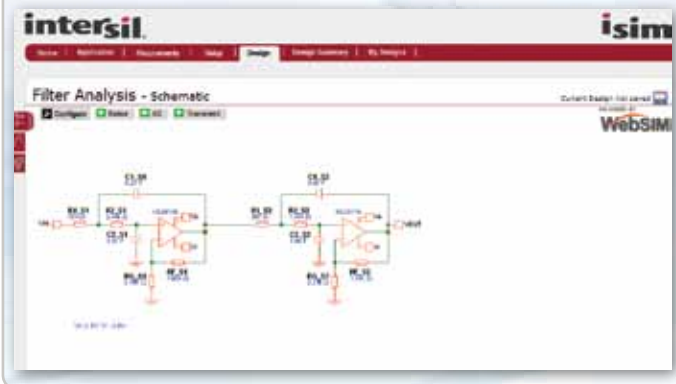

4 Summary, Download, Design & More

Once the design has been verified, iSim generates a Bill of Materials and a comprehensive design report including simulation results, schematic and design data.

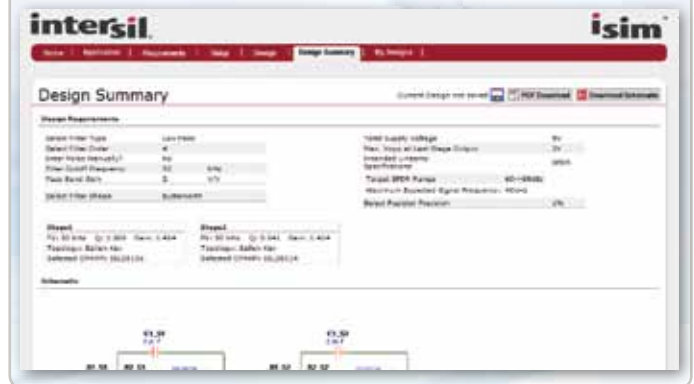

NORTH AMERICA

WEST COAST
Intersil Headquarters
1001 Murphy Ranch Road
Milpitas, CA 95035
(TEL) 408-432-8888
(FAX) 408-434-5351
1-888-INTERSIL
1-888-468-3774

EAST COAST
1650 Robert J Conlan Blvd NE
Palm Bay, FL 32905
(TEL) 321-724-7000
(FAX) 321-729-7320
1-888-INTERSIL
1-888-468-3774

EUROPE

Oskar-Messter-Str. 29
D-85737 Ismaning
Germany
(TEL) +49-89-46263-0
(FAX) +49-89-46263-148

ASIA PACIFIC

Suite 501, 5/F,
Ocean Centre, Harbour City,
Tsimshatsui, Kowloon
Hong Kong
(TEL) +852-2709-7600
(FAX) +852-2730-1433

JAPAN

6F, Mita Nitto Daibiru
3-11-36, Mita, Minato-ku
Tokyo, 108-0073 Japan
(TEL) +81-3-5439-2311
(FAX) +81-3-5439-2300

