

SIEMENS

ICs for Consumer Electronics MEGATEXT and MEGATEXT PLUS ICs

SDA 5273 / SDA 5275

SDA 5273-2 / SDA 5275-2

Data Sheet 1997-09-01

MEGATEXT [®] and MEGATEXT PLUS ICs SDA 5273 / SDA 5275 SDA 5273-2 / SDA 5275-2 Revision History: 1997-09-01	
Previous Releases: 11.96	
Page	Subjects (changes since last revision)
20	Now also covers SDA 5275-2 and SDA 5273-2 versions; Reset/chip initialization update

Data Classification

Maximum Ratings

Maximum ratings are absolute ratings; exceeding only one of these values may cause irreversible damage to the integrated circuit.

Characteristics

The listed characteristics are ensured over the operating range of the integrated circuit. Typical characteristics specify mean values expected over the production spread. If not otherwise specified, typical characteristics apply at $T_A = 25\text{ °C}$ and the given supply voltage.

Operating Range

In the operating range the functions given in the circuit description are fulfilled.

For detailed technical information about “**Processing Guidelines**” and “**Quality Assurance**” for ICs, see our “**Short Form Catalog**”.

Edition 1997-09-01

**Published by Siemens AG, Bereich Halbleiter, Marketing-Kommunikation,
Balanstraße 73, 81541 München**

© Siemens AG 1997. All Rights Reserved.

As far as patents or other rights of third parties are concerned, liability is only assumed for components, not for applications, processes and circuits implemented within components or assemblies.

The information describes the type of component and shall not be considered as assured characteristics.

Terms of delivery and rights to change design reserved.

For questions on technology, delivery and prices please contact the Semiconductor Group Offices in Germany or the Siemens Companies and Representatives worldwide (see address list).

Due to technical requirements components may contain dangerous substances. For information on the types in question please contact your nearest Siemens Office, Semiconductor Group.

Siemens AG is an approved CECC manufacturer.

Packing

Please use the recycling operators known to you. We can also help you - get in touch with your nearest sales office. By agreement we will take packing material back, if it is sorted. You must bear the costs of transport.

For packing material that is returned to us unsorted or which we are not obliged to accept, we shall have to invoice you for any costs incurred.

Contents		Page
1	Features	4
1.1	Pin Definitions and Functions	6
1.2	Pin Definitions and Functions	9
2	Electrical Characteristics	12
3	Diagrams	21
4	Package Outlines	29

MEGATEXT® is a registered trademark of Siemens AG

MEGATEXT® and MEGATEXT PLUS ICs

SDA 5273 / 75
SDA 5273-2 / 75-2

Preliminary Data

CMOS IC

1 Features

- Single chip teletext IC
- Analog CVBS-input with onchip clamping circuitry
- Slicer
- Supports level 1, 2.5 and 3.5 ETSI teletext standard
- Stores up to 14 teletext pages on chip
- Stores up to 2048 teletext pages with external 16 M memory
- SDA 5275: full level 2.5 processing

- Analog RGB-output
- 41 latin script languages
- 12 × 10 character size
- Parallel display attributes
- 64 from 4096 colors selectable
- Enhanced flash modes
- Dynamically redefinable character set (DRCS, PCS)
- Pixel graphics
- Fullscreen display (64 × 32 or 80 × 24 character positions)
- Horizontal and vertical scrolling
- Graphic cursors
- 4:3 and 16:9 display
- Multinorm display (50/60/100/120 Hz)

- RISC-processor
- Firmware downloadable
- I²C / 3 wire UART-interface (1 Mbit/s)
- Independent clocks for acquisition and display
- Tools for greatly simplified software development

- 24-Kbyte on-chip reconfigurable DRAM
- 44160-bit character ROM
- One external crystal for all standards

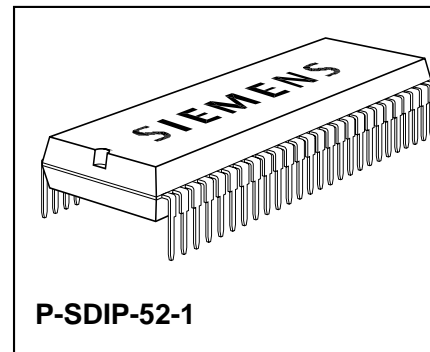
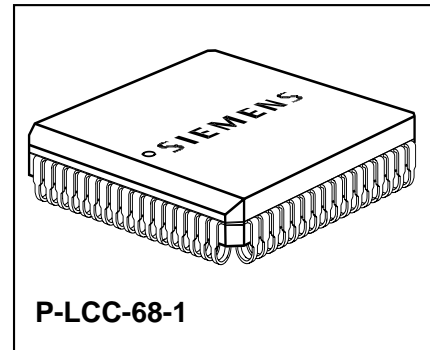

Type	Ordering Code	Package
SDA 5273 / 75 P	on request	P-LCC-68-1
SDA 5273 / 75 S	on request	P-SDIP-52-1
SDA 5273-2 / 75-2P	on request	P-LCC-68-1
SDA 5273-2 / 75-2S	on request	P-SDIP-52-1
SDA 5273C / 73-2C P	on request	P-LCC-68-1
SDA 5273C / 73-2C S	on request	P-SDIP-52-1

Pin Configuration

(top view)

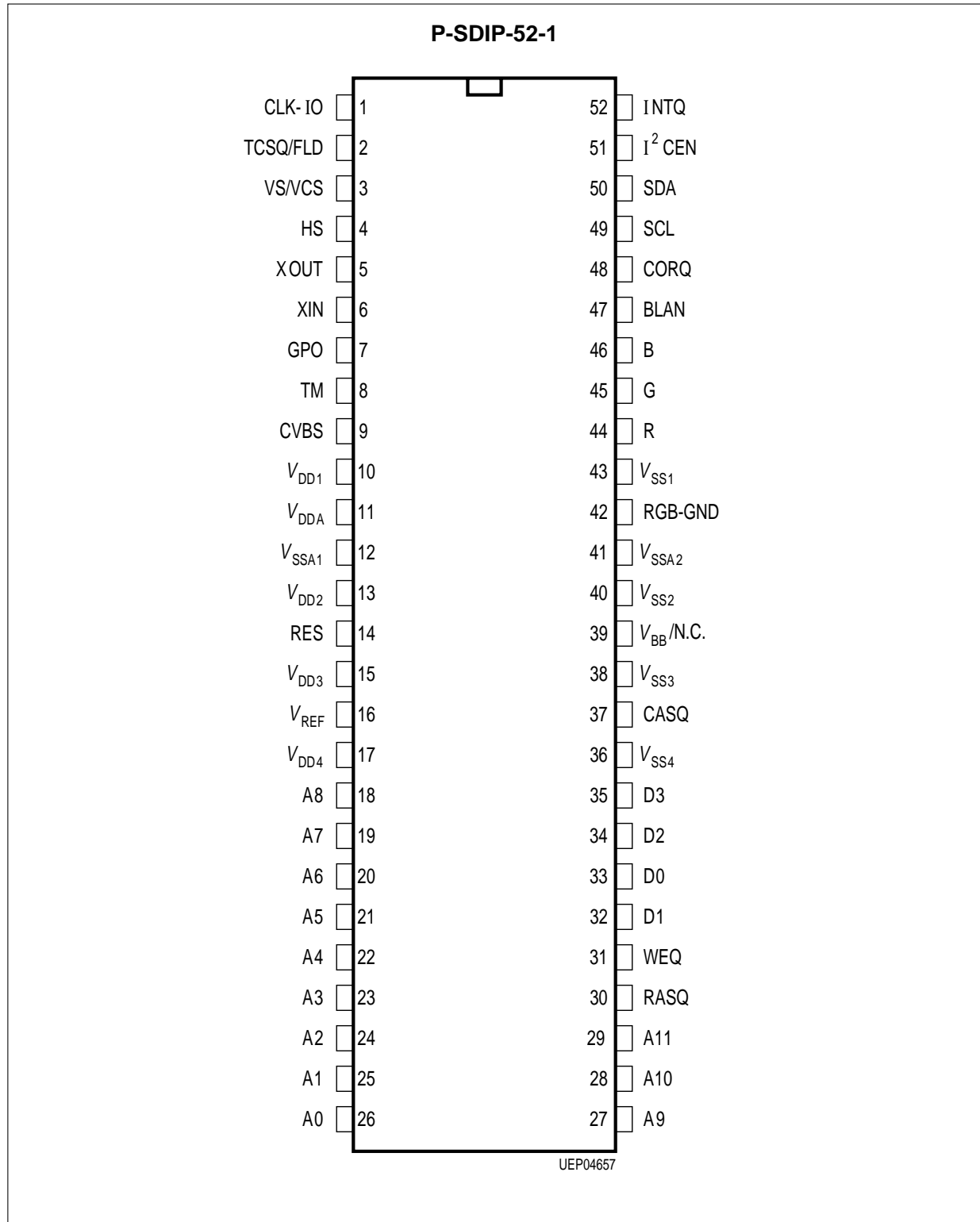

1.1 Pin Definitions and Functions

Pin No. P-SDIP-52-1	Symbol	Function
1	CLK-IO	System clock input/output
2	TCSQ/FLD	Composite sync output/ field output
3	VS/VCS	Vertical sync input/output
4	HS	Horizontal sync input/output
5	XOUT	20.5-MHz crystal oscillator output
6	XIN	20.5-MHz crystal oscillator input
7	GPO	General purpose output
8	TM	Testpin, leave open or connect to V_{SS}
9	CVBS	CVBS-video signal input
10	V_{DD1}	+ 5 V digital supply
11	V_{DDA}	+ 5 V analog supply
12	V_{SSA1}	Analog ground
13	V_{DD2}	+ 5 V digital supply
14	RES	Chip reset
15	V_{DD3}	+ 5 V digital supply
16	V_{REF}	+ 3 V reference voltage input
17	V_{DD4}	+ 5 V digital supply
18	A8	External DRAM-address
19	A7	External DRAM-address
20	A6	External DRAM-address
21	A5	External DRAM-address
22	A4	External DRAM-address
23	A3	External DRAM-address
24	A2	External DRAM-address
25	A1	External DRAM-address
26	A0	External DRAM-address
27	A9	External DRAM-address
28	A10	External DRAM-address
29	A11	External DRAM-address
30	RASQ	Row address strobe (DRAM)
31	WEQ	Write enable (DRAM)
32	D1	External DRAM-data

1.1 Pin Definitions and Functions (cont'd)

Pin No. P-SDIP-52-1	Symbol	Function
33	D0	External DRAM-data
34	D2	External DRAM-data
35	D3	External DRAM-data
36	V_{SS4}	0 V digital supply
37	CASQ	Column address strobe
38	V_{SS3}	0 V digital supply
39	V_{BB}	Substrate bias voltage N.C. ¹⁾
40	V_{SS2}	0 V digital supply
41	V_{SSA2}	Analog ground
42	RGB-GND	RGB-ground
43	V_{SS1}	0 V digital supply
44	R	Analog red display output
45	G	Analog green display output
46	B	Analog blue display output
47	BLAN	Blanking signal open drain output
48	CORQ	Contrast reduction open drain output
49	SCL	Bidirectional I ² C Bus clock port
50	SDA	Bidirectional I ² C Bus data port
51	I ² CEN	I ² C Bus enable
52	INTQ	Interrupt request output to ext. controller

¹⁾ Depends on version. Please refer to the respective Delta Specification.

Pin Configuration

(top view)

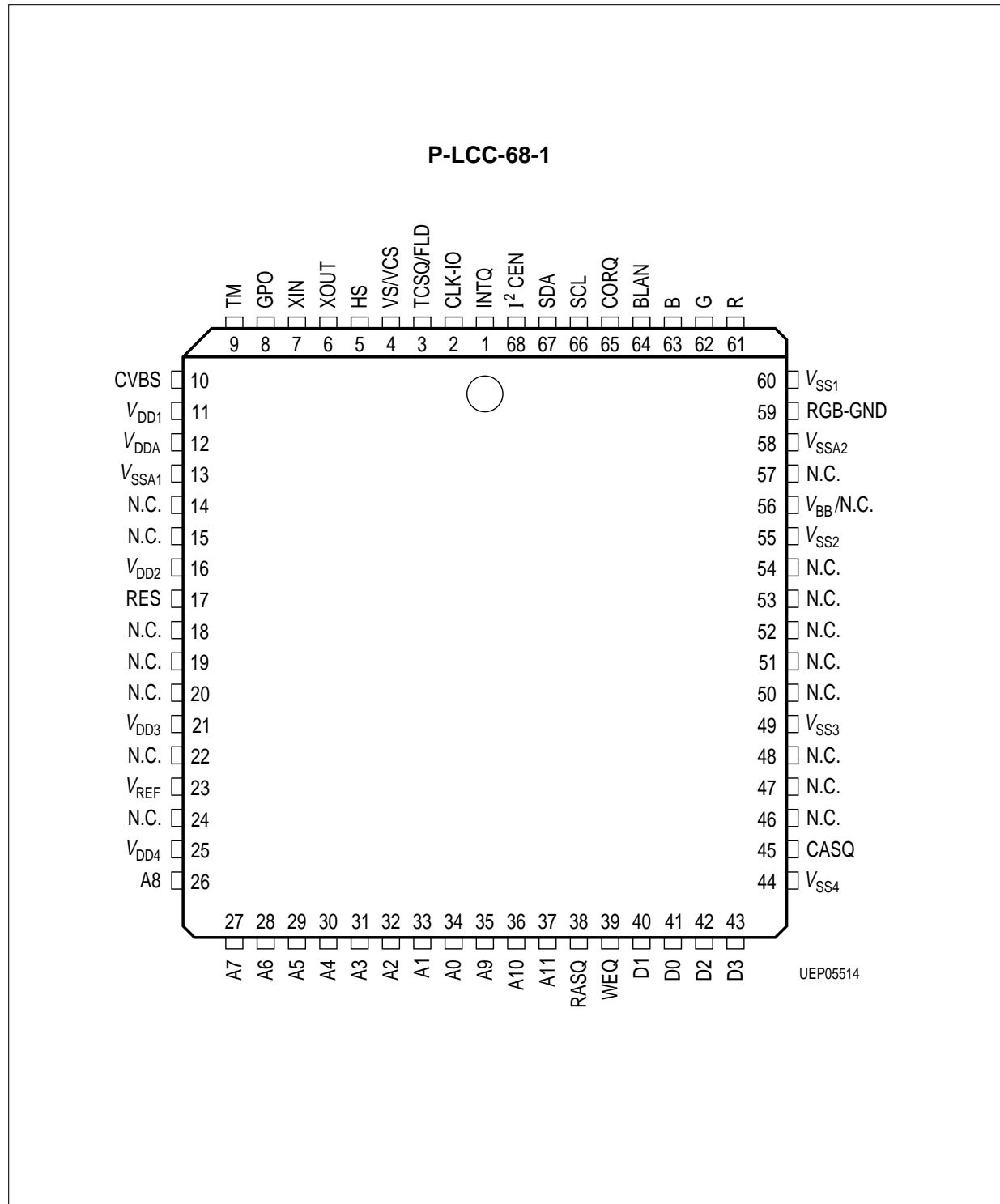

1.2 Pin Definitions and Functions

Pin No. P-LCC-68-1	Symbol	Function
1	INTQ	Interrupt request output to ext. controller
2	CLK-IO	System clock input/output
3	TCSQ/FLD	Composite sync output/ field output
4	VS/VCS	Vertical sync input/output
5	HS	Horizontal sync input/output
6	XOUT	20.5-MHz crystal oscillator output
7	XIN	20.5-MHz crystal oscillator input
8	GPO	General purpose output
9	TM	Testpin, leave open or connect V_{SS}
10	CVBS	CVBS-video signal input
11	V_{DD1}	+ 5 V digital supply
12	V_{DDA}	+ 5 V analog supply
13	V_{SSA1}	Analog ground
14	N.C.	Not connected
15	N.C.	Not connected
16	V_{DD2}	+ 5 V digital supply
17	RES	Chip reset
18	N.C.	Not connected
19	N.C.	Not connected
20	N.C.	Not connected
21	V_{DD3}	+ 5 V digital supply
22	N.C.	Not connected
23	V_{REF}	+ 3 V reference voltage input
24	N.C.	Not connected
25	V_{DD4}	+ 5 V digital supply
26	A8	External DRAM-address
27	A7	External DRAM-address
28	A6	External DRAM-address
29	A5	External DRAM-address
30	A4	External DRAM-address
31	A3	External DRAM-address
32	A2	External DRAM-address

1.2 Pin Definitions and Functions (cont'd)

Pin No. P-LCC-68-1	Symbol	Function
33	A1	External DRAM-address
34	A0	External DRAM-address
35	A9	External DRAM-address
36	A10	External DRAM-address
37	A11	External DRAM-address
38	RASQ	Row address strobe (DRAM)
39	WEQ	Write enable (DRAM)
40	D1	External DRAM-data
41	D0	External DRAM-data
42	D2	External DRAM-data
43	D3	External DRAM-data
44	V_{SS4}	0 V digital supply
45	CASQ	Column address strobe
46	N.C.	Not connected
47	N.C.	Not connected
48	N.C.	Not connected
49	V_{SS3}	0 V digital supply
50	N.C.	Not connected
51	N.C.	Not connected
52	N.C.	Not connected
53	N.C.	Not connected
54	N.C.	Not connected
55	V_{SS2}	0 V digital supply
56	V_{BB}	Substrate bias voltage N.C. ¹⁾
57	N.C.	Not connected
58	V_{SSA2}	Analog ground
59	RGB-GND	RGB-ground
60	V_{SS1}	0 V digital supply
61	R	Analog red display output
62	G	Analog green display output
63	B	Analog blue display output

¹⁾ Depends on version. Please refer to the respective Delta Specification.

1.2 Pin Definitions and Functions (cont'd)

Pin No. P-LCC-68-1	Symbol	Function
64	BLAN	Blanking signal open drain output
65	CORQ	Contrast reduction open drain output
66	SCL	Bidirectional I ² C Bus clock port
67	SDA	Bidirectional I ² C Bus data port
68	I ² CEN	I ² C Bus enable

2 Electrical Characteristics

Absolute Maximum Ratings

Parameter	Symbol	Limit Values			Unit	Test Condition
		min.	typ.	max.		
Supply voltage	V_{DD}	0		6.0	V	
Ambient temperature	T_A	0		70	°C	
Storage temperature	T_{stg}	- 20		125	°C	
Power consumption	P_{tot}			1.8	W	
Electrostatic discharge			2000		V	100 pF, 1 kΩ HBM according to MIL-standard 883 method 3015.7

Characteristics

$T_A = 0$ to 70 °C

Parameter	Symbol	Limit Values			Unit	Test Condition
		min.	typ.	max.		

Supply Voltages

	V_{DDD}	4.7	5.0	5.3	V	
	V_{DDA}	4.7	5.0	5.3	V	$V_{DDD} = V_{DDA}$!

Supply Currents

	I_{DDD}			200	mA	20 pF load per pin
	I_{DDA}			60	mA	

Inputs

Tristate of Outputs: I²CEN, HS, VS, GPO, RES, D0-D3

H-input voltage	V_{IH}	2.0		V_{DDD}	V	
L-input voltage	V_{IL}	- 1.0		0.8	V	
Input capacitance	C_I			7	pF	
Input leakage current	I_L			10	μA	$V_{IH} = 5.5$ V
Input current RES	I_{IH}			100	μA	$V_{IH} = 5.5$ V

Characteristics (cont'd)

$T_A = 0$ to $70\text{ }^\circ\text{C}$

Parameter	Symbol	Limit Values			Unit	Test Condition
		min.	typ.	max.		

Outputs

TTL-Outputs: A0-A11, D0-D3, RASQ, CASQ, WEQ, HS, VS, GPO, INTQ, TCSQ

H-output voltage	V_{OH}	2.4		V_{DD}	V	$-I_{OH} = 0.2\text{ mA}$
L-output voltage	V_{OL}	0		0.4	V	$I_{OL} = 1.6\text{ mA}$
Load capacitance	C_L			50	pF	
Transition period	t_r, t_f			15	ns	

Open Drain Outputs: BLAN, CORQ

Sink current	I_{OL}			5	mA	low level output
L-output voltage	V_{OL}			0.4	V	$I_{OL} = 2\text{ mA}$
H-output voltage	V_{OH}			V_{DD}	V	

BLAN = 1: display MEGATEXT RGB-outputs
 BLAN = 0; display other source
 CORQ = 1; switch contrast reduction OFF
 CORQ = 0; switch contrast reduction ON

Sourcefollower Output: CVBS at pin TCSQ

DC-offset to CVBS-input			1.2		V	
Gain	G		0.9			
Output current	I_O	0.9			mA	CVBS = 1 V, TCSQ = 0 V
Output impedance	R_O		200		Ω	CVBS = 1 V
Edge response	t_r			1	μs	10 to 90 %, 1 Vpp, $C_L = 50\text{ pF}$

Sync Timing: HS, VS, TCSQ

Sync Output Waveforms

Pulse width HS	t_{WH}		2		μs	
Pulse width VS	t_{WH}		1		line	
VCS-waveform						see diagram 6a, b
TCSQ-waveform						see diagram 6a, b

Characteristics (cont'd)

$T_A = 0$ to 70 °C

Parameter	Symbol	Limit Values			Unit	Test Condition
		min.	typ.	max.		

Output Timing: HS, VS, TCSQ

Hold and delay time with respect to 24-MHz system clock output:						
Delay time	t_{OD}			20	ns	see diagram 2
Hold time	t_{OH}	0			ns	see diagram 2
Hold and delay time with respect to 24-MHz external system clock input:						
Delay time						not specified
Hold time						not specified

Input Timing: HS, VS

No synchronous input mode specified!

Clock Input/Output (see diagram 1)

Clock Input

H-input voltage	V_{IH}	2.0		V_{DD}	V	
L-input voltage	V_{IL}	- 1.0		0.8	V	
Input capacitance	C_I			7	pF	
Input leakage current	I_I			10	μA	$V_{IH} = 5.5$ V
Period	T_c	40				24-MHz clock
	T_c	35				27-MHz clock
Transition time	t_{CR}, t_{CL}			3	ns	
Symmetry ratio	t_{CH}/t_C	0.43		0.57		

Clock Output

H-output voltage	V_{OH}	2.4		V_{DD}	V	$-I_{OH} = 0.2$ mA
L-output voltage	V_{OL}	0		0.4	V	$I_{OL} = 1.6$ mA
Load capacitance	C_L			50	pF	
Period	T_c		41.7		ns	20.5-MHz crystal
Transition time	t_{CR}, t_{CF}			5	ns	
Symmetry ratio	t_{CH}/t_C	0.3		0.5	ns	

Characteristics (cont'd)

$T_A = 0$ to $70\text{ }^\circ\text{C}$

Parameter	Symbol	Limit Values			Unit	Test Condition
		min.	typ.	max.		

RGB-Outputs

						$V_{REF} = 3\text{ V}$ no resistive load RGB-GND = 0 V
Pin capacitance	C_P			7	V	
Output voltage range		0		2.2	V	
RGB-amplitude		1.1	1.25	1.55	V	R83: RGB-GAIN (4:0) = $1F_H$
DC-offset voltage		0.7	0.8	1.0	V	R83: RGB-LEVL (2:0) = 7
Clamp level			0		V	
DAC-resolution			4		bit	
Diff. non-linearity		- 0.5		0.5	LSB	R83: RGB-GAIN (4:0) = $1F_H$ RGB-LEVL (2:0) = 0
Int. non-linearity		- 0.5		0.5	LSB	
Output tracking		- 0.5		0.5	LSB	
Output resistance	R_O		270		Ω	
3-dB bandwidth	$\frac{1}{2\pi R_O C_L}$		10		MHz	$C_L = 50\text{ pF}$

Bus Connection: SDA, SCL, I²CEN (see diagram 4)

Inputs: SDA, SCL

H-input voltage	V_{IH}	3.0		V_{DD}	V	
L-input voltage	V_{IL}	- 1.0		1.5	V	
Input capacitance	C_I			7	pF	
Input leakage current	I_L			10	μA	$V_{IH} = 5.5\text{ V}$ $V_{DD} = 0\text{ V} \dots 5.5\text{ V}$

For modes with external clock MEGATEXT may only be operated in freerun mode as sync master. HS may not be used as an input in these cases.

The RGB-output voltage is proportional to V_{REF} .

Characteristics (cont'd)

$T_A = 0$ to $70\text{ }^\circ\text{C}$

Parameter	Symbol	Limit Values			Unit	Test Condition
		min.	typ.	max.		

Open Drain Outputs: SDA, SCL

L-output voltage	V_{OL}	0		0.4	V	$I_{OL} = 3\text{ mA}$
Sink current	I_{OL}			10	mA	

I²C-Mode Timing

MEGATEXT is an I²C-slave transmitter/receiver.
The Siemens I²C Bus specification applies.

SCL-frequency	f_{SCL}	0		100	kHz	I ² CEN = high
Transition time	t_r, t_f			2	μs	
Bus capacitance	C_{BUS}			400	pF	
Bus free before start	t_{BUF}	4.7			μs	
Hold time start	t_{HSTA}	4.0			μs	
L-time clock	t_{LOW}	4.0			μs	
H-time clock	t_{HIGH}	4.0			μs	
Set-up time start	t_{SUSTA}	4.0			μs	
Hold time SDA	t_{HDDAT}	0			μs	
Set-up time SDA	t_{SUDAT}	250			ns	
Set-up time SDA at stop	t_{SUSTO}	4.0			μs	
Output fall time	t_{FO}			0.2	μs	3 V to 1 V

M3L-Mode Timing

The MEGATEXT M3L-Bus is specified in accordance with the standard USART-interface of micro controller SDA 30C162.

SCL-frequency	f_{SCL}	0		1.0	MHz	20.48-MHz crystal
L-time clock	t_L	400			ns	
H-time clock	t_H	400			ns	
SCL-load capacitance	C_{SCL}			200	pF	
Set-up time SDA-input to SCL-falling edge	t_{DSL}	100			ns	
Hold time SDA-input from SCL-falling edge	t_{DHH}	400			ns	

Characteristics (cont'd)

$T_A = 0$ to 70 °C

Parameter	Symbol	Limit Values			Unit	Test Condition
		min.	typ.	max.		

M3L-Mode Timing (cont'd)

Set-up time SDA to I ² CEN-rising edge	t_{IM}	400			ns	
Set up time I ² CEN to SDA-falling edge	t_{IS}	400			ns	
I ² CEN-high time	t_{IH}	1000			ns	
Delay from SCL-falling edge until SDA-open drain output stage changes impedance	t_{DO}	400		600	ns	
L-SDA level output impedance			100		Ω	

The resulting delay of SDA-output data is the sum of the open drain stage plus the time determined by the bus capacitance and the external pullup resistor or the impedance of the internal open drain pulldown transistor respectively.

Wait condition						I ² CEN = 0
----------------	--	--	--	--	--	------------------------

To force the M3L-master to interrupt the transmission sequence until MEGATEXT is ready for more data, MEGATEXT can force down SCL after the transmission of a complete byte. At that time the bus master has to switch its SCL-output to high impedance and check the state of SCL afterwards. During SCL check I²CEN has to be low.

Delay from SCL-rising edge to SCL forced low for WAIT-condition	t_{DWAIT}	500		750	ns	
---	-------------	-----	--	-----	----	--

An internal pullup transistor restores SCL high level at the end of the WAIT-condition.

SCL-pullup time at the end of WAIT	t_{RWAIT}	70		100	ns	
------------------------------------	-------------	----	--	-----	----	--

Reference Voltage: V_{REF}

Voltage level	V_{REF}	2.8	3.0	3.5	V	
Input leakage current	I_I	- 10		10	μA	$V_{REF} = 3$ V

V_{REF} influences the DAC-range, the CVBS-output at pin TCSQ and the CVBS-ADC range.

Characteristics (cont'd)

$T_A = 0$ to 70 °C

Parameter	Symbol	Limit Values			Unit	Test Condition
		min.	typ.	max.		

CVBS-Input and ADC ($V_{REF} = 3$ V)

Input leakage current	I_I	- 1.0		1.0	μ A	CVBS = 2 V
Input capacitance	C_P			45	pF	
Ext. coupling capacitance	C_{CPL}		100		nF	
Sensitivity of clamp level to current leakage/injection		- 15		15	mV/ μ A	$I_I = 2 \mu$ A $C_{CPL} = 100$ nF
ADC-range		1.7		2.0	V	$V_{REF} = 3$ V
CVBS-sync amplitude		0.1			V	

Crystal Oscillator: XIN, XOUT

Bias resistance between XIN, XOUT	R_{Xbias}	60	120	180	k Ω	
Small signal voltage gain	G_V	8	13			100 kHz, 50 mVpp
Feedback capacitance	C_{FB}			4.0	pF	
Pin capacitance	C_P			7.0	pF	

Crystal

Nominal frequency	f_O		20.48		MHz	
Effect of temperature and accuracy of adjustment	df/f_O	- 5 %		+ 5 %		
Temperature range	T_A	0		70	°C	
Resonant impedance	Z_R			40	Ω	
Equivalent parallel C	C_L		15		pF	
Crystal load				0.1	mW	
Ext. capacitors	$C_{1,2}$		15		pF	

The center frequency of the MEGATEXT horizontal PLL is proportional to the crystal frequency. In PAL-mode the centre frequency is 15.625 kHz for the typical crystal frequency of 20.48 MHz. Deviations from the typical crystal frequency will shift the range of the horizontal frequencies where the PLL is able to lock.

Characteristics (cont'd)

$T_A = 0$ to $70\text{ }^\circ\text{C}$

Parameter	Symbol	Limit Values			Unit	Test Condition
		min.	typ.	max.		

DRAM-Interface (see diagram 5)

The external DRAM is operated in page mode.

The timing of the DRAM-interface signals are specified below.

Cycle time	t_{WC}	420	500	550	ns	
Address hold time from RAS	t_{RAH}	25			ns	
Address hold time from CAS	t_{CAH}	60			ns	
Address set-up time from RAS	t_{ASR}	5			ns	
Address set-up time from CAS	t_{ASC}	5			ns	
L-time RAS	t_{RASP}	280			ns	
L-time CAS	t_{CASL}	70			ns	
H-time RAS	t_{RP}	140			ns	
H-time CAS	t_{CP}	70			ns	
Refresh period		20			ms	

Write Cycle

L-time WE	t_{WEL}	210			ns	
Data set-up time to CAS	t_{DS}	100			ns	
WE set-up time to CAS	t_{RCS}	0			ns	
Data hold time from CAS	t_{DH}	55			ns	
Data hold time from WE	t_{OHZ}			10	ns	

Read Cycle

H-time WE (output enable)	t_{OEL}	210			ns	
Access time from CAS	t_{CAC}			60	ns	
Data hold time of DRAM	t_{OFF}	40			ns	

Characteristics (cont'd)

$T_A = 0 \text{ to } 70 \text{ }^\circ\text{C}$

Parameter	Symbol	Limit Values			Unit	Test Condition
		min.	typ.	max.		

Reset/Chip Initialization

A power-on reset or a reset pulse at pin RES lead to a hardware reset and a software initialization of registers and internal DRAM. During initialization bus transfers are not allowed.

At / after power-on a reset pulse at pin RES is necessary. RES may return to 0 after the supply voltage reached its lower limit for chip function (4.7 V). This may be achieved by a capacitor C between RES and V_{DD} and by a resistor R between RES and V_{SS} . The dimensions of R and C depend on the worst case rise time of V_{DD} .

Initialization time after power-on or falling edge of RES	t_{INIT}			25	ms	V_{DD} greater 4.7 V
---	------------	--	--	----	----	------------------------

If the supply voltage drops below $V_{DD\ min}$, the IC has to be reset by pin RES.

Pulse width RES		100			ns	
-----------------	--	-----	--	--	----	--

High level at pin RES causes chip reset.

In rare cases, the IC may remain in a permanent reset state after power up, depending on the applicational context. After power up, the software should check proper operation. In case the Megatext does not react properly, power supply should be switched off for at least 3 s. After that, power supply can be switched on again.

Other Items

Horizontal frequency pull-in range of CVBS-PLL:		15	15.625	16.2	kHz	PAL 20.48 MHz crystal
		15.2	15.748	16.3	kHz	NTSC 20.48 MHz crystal
Horizontal frequency pull-in range of display-PLL:		15	15.625	16.2	kHz	20.48 MHz crystal

3 Diagrams

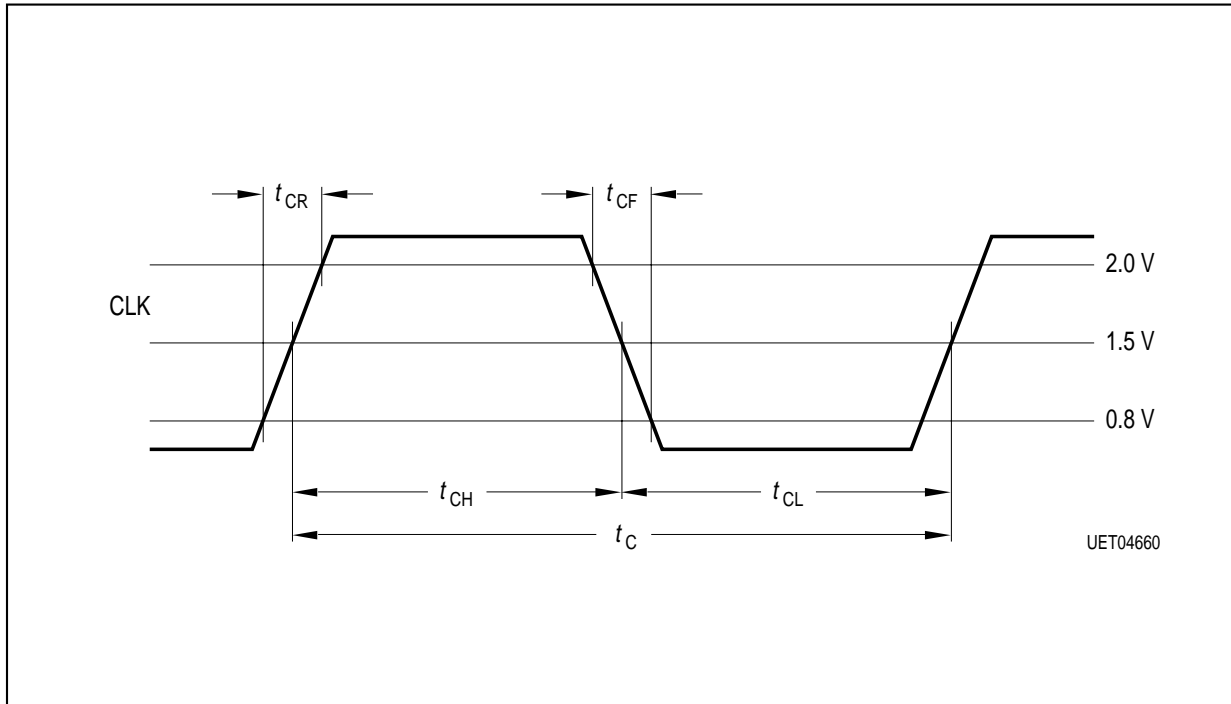

Timing Diagram 1

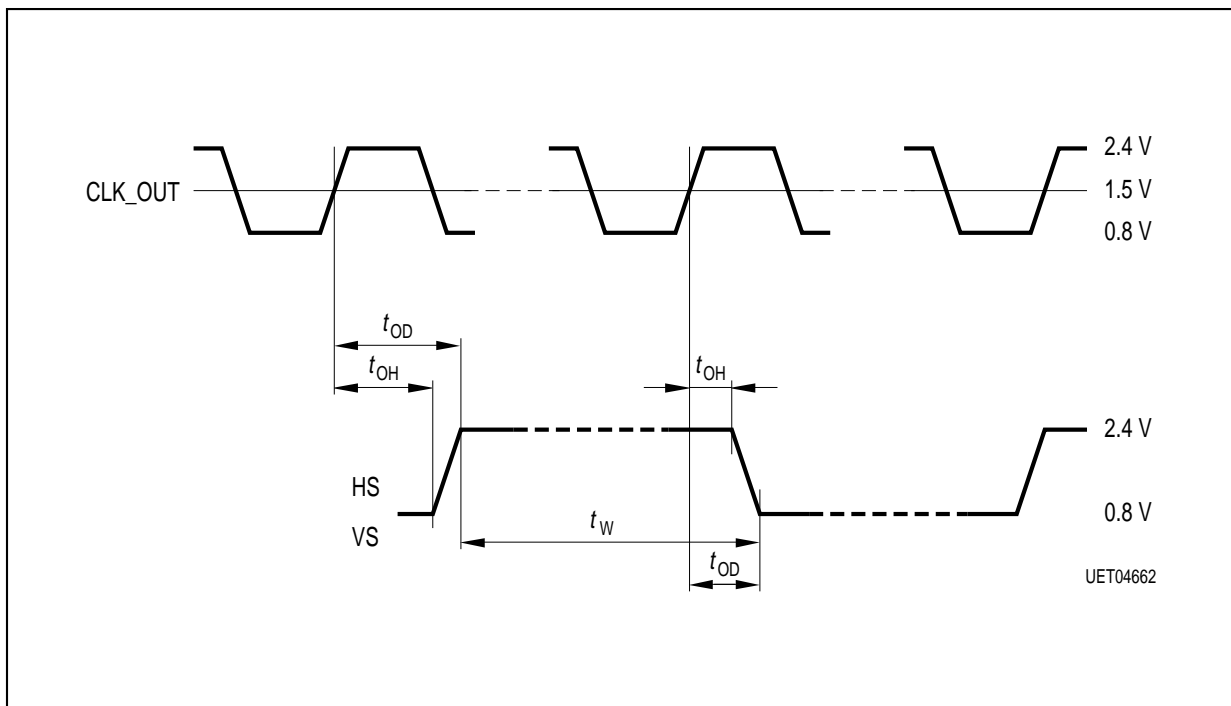

Timing Diagram 2

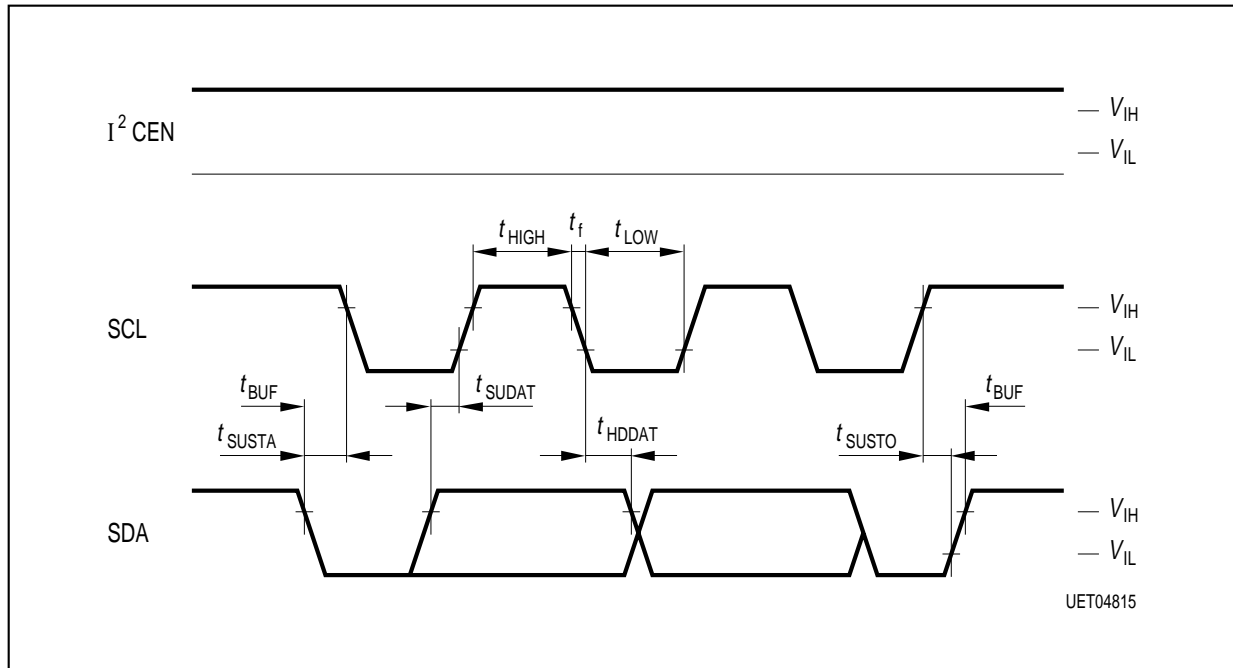

Timing Diagram 3a
I²C-Bus Mode

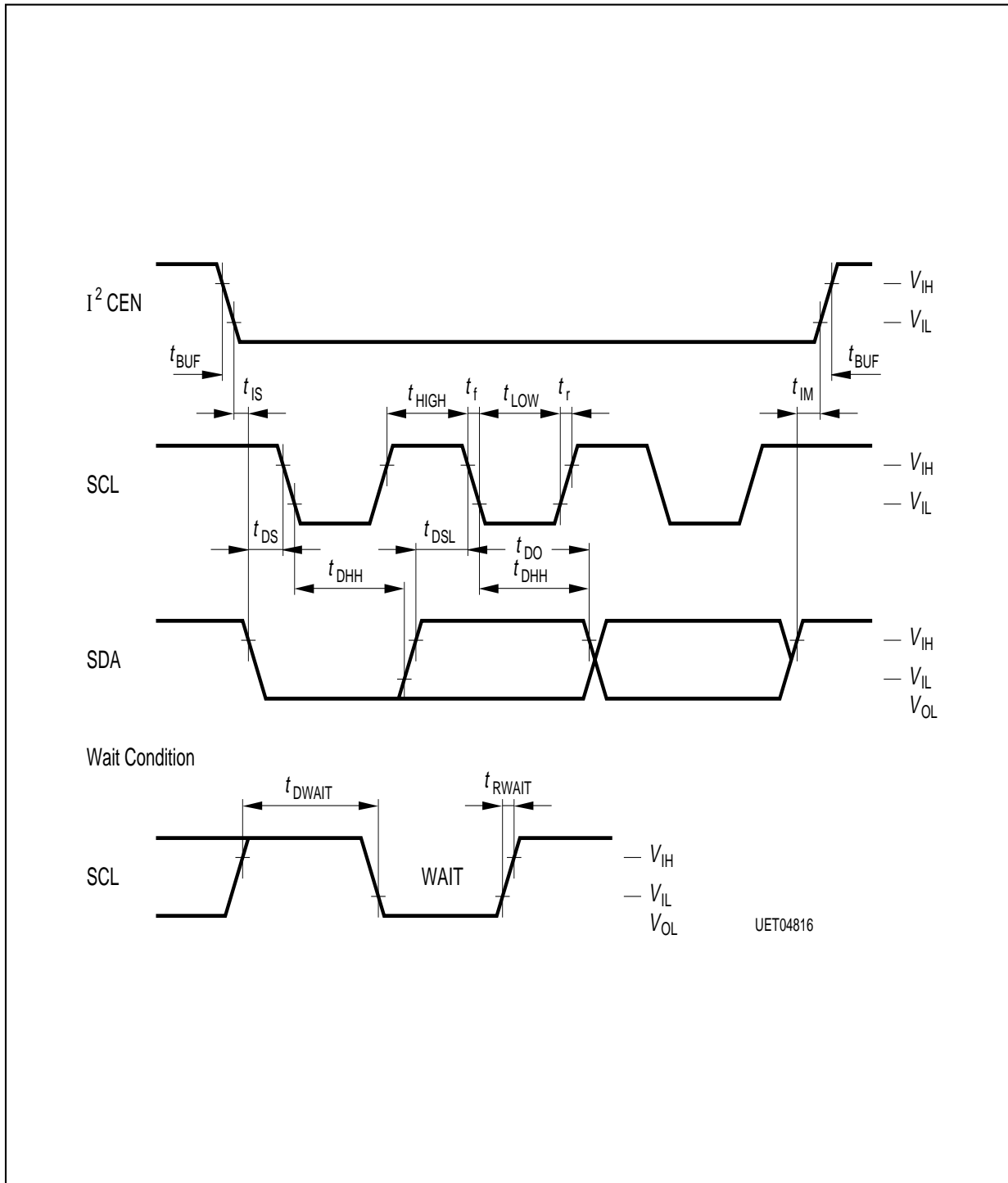

Timing Diagram 3b
M3L-Bus Mode

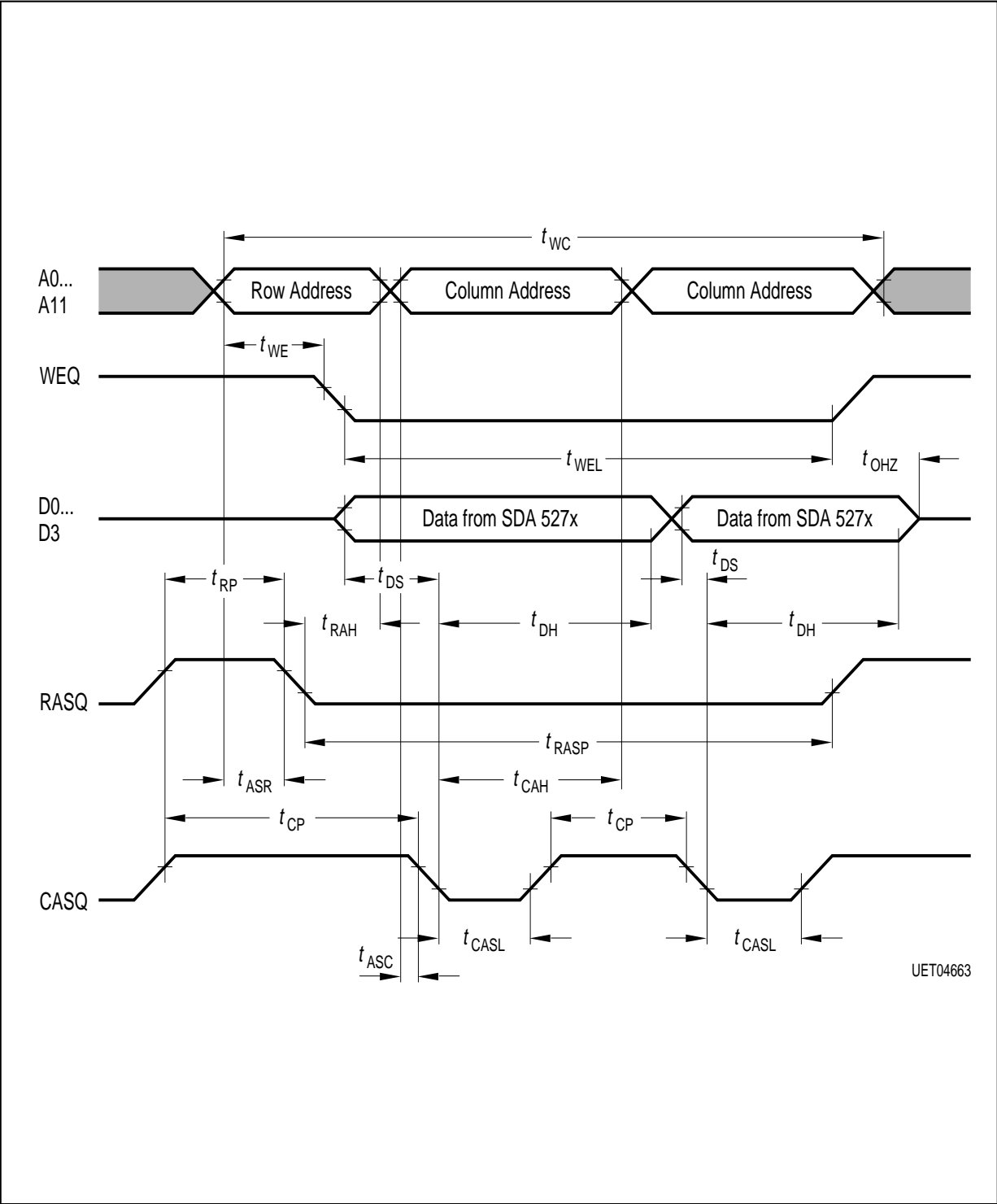

UET04663

Timing Diagram 4a
DRAM-Page Mode Write Cycle

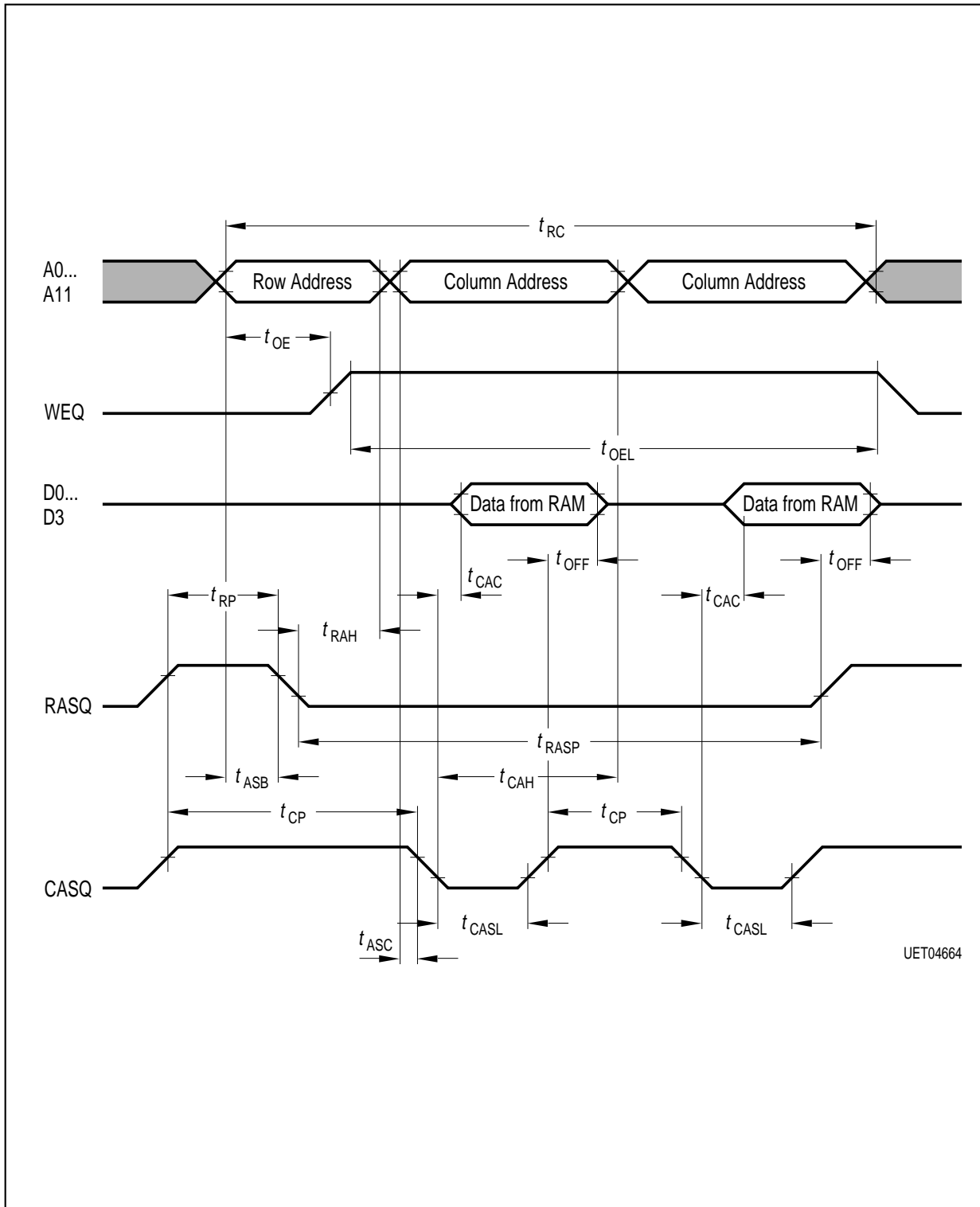

Timing Diagram 4b
DRAM-Page Mode Read Cycle

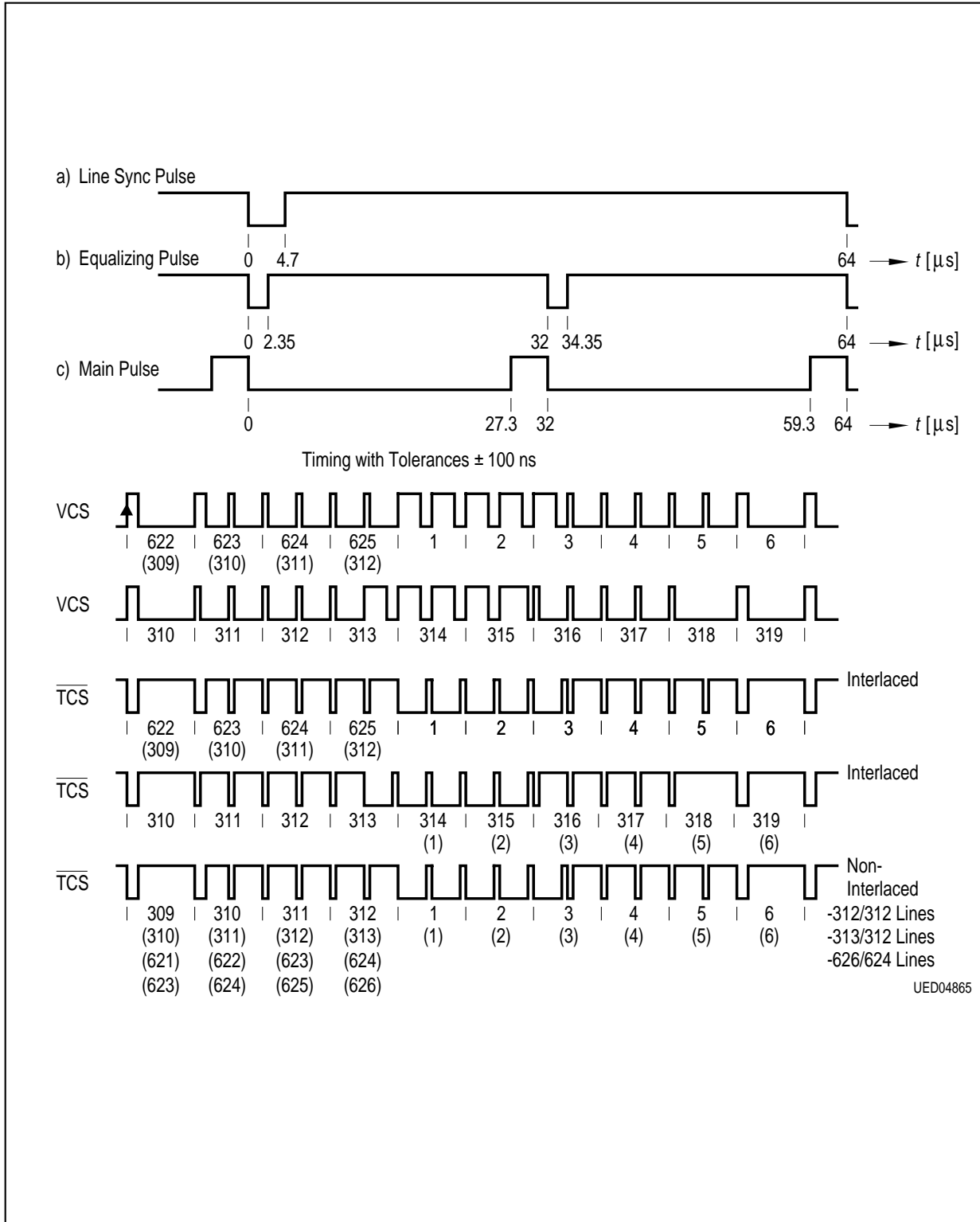

Timing Diagram 5a
VCS and TCS in PAL Freerun Mode

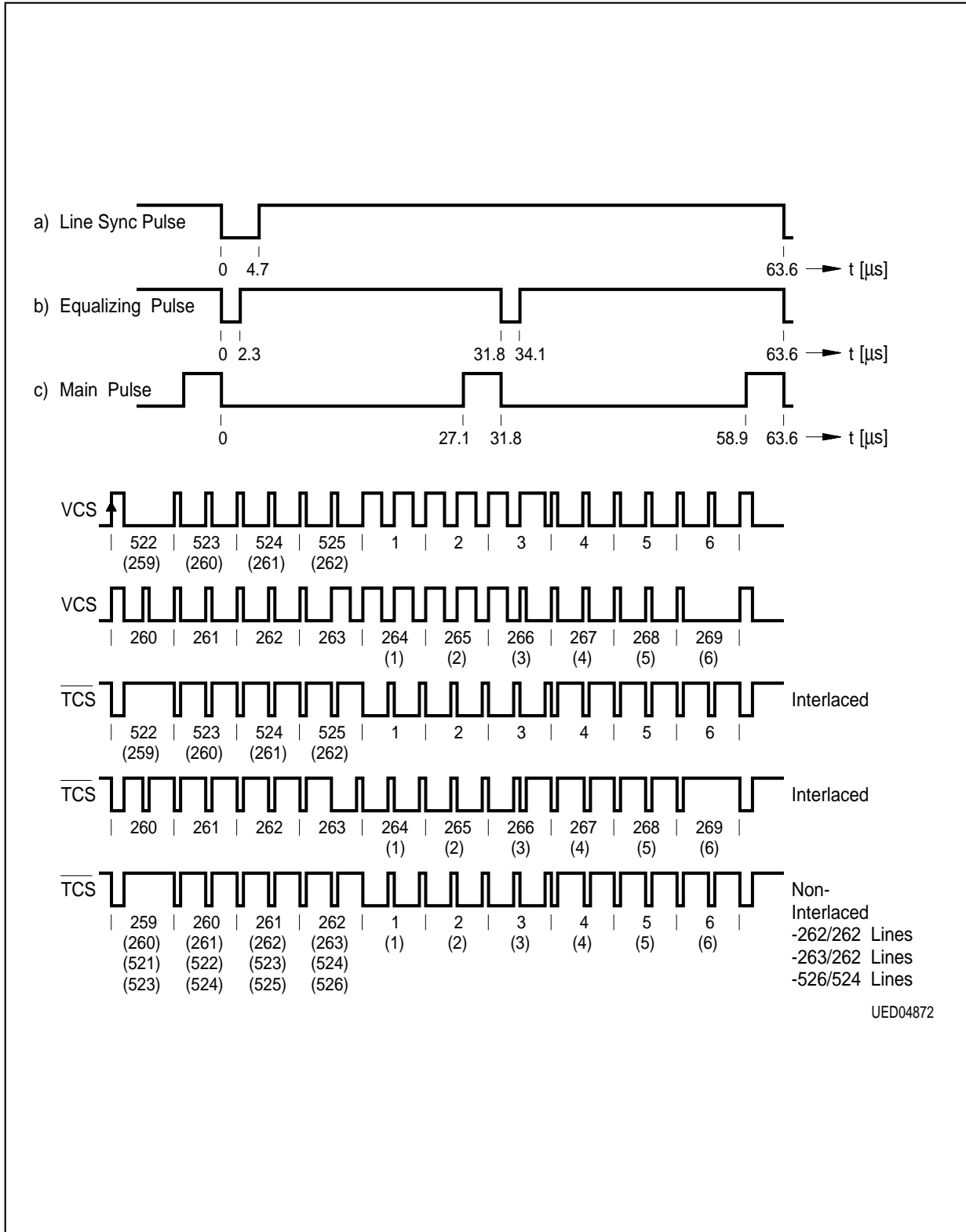

Timing Diagram 5b
VCS and TCS in NTSC Freerun Mode

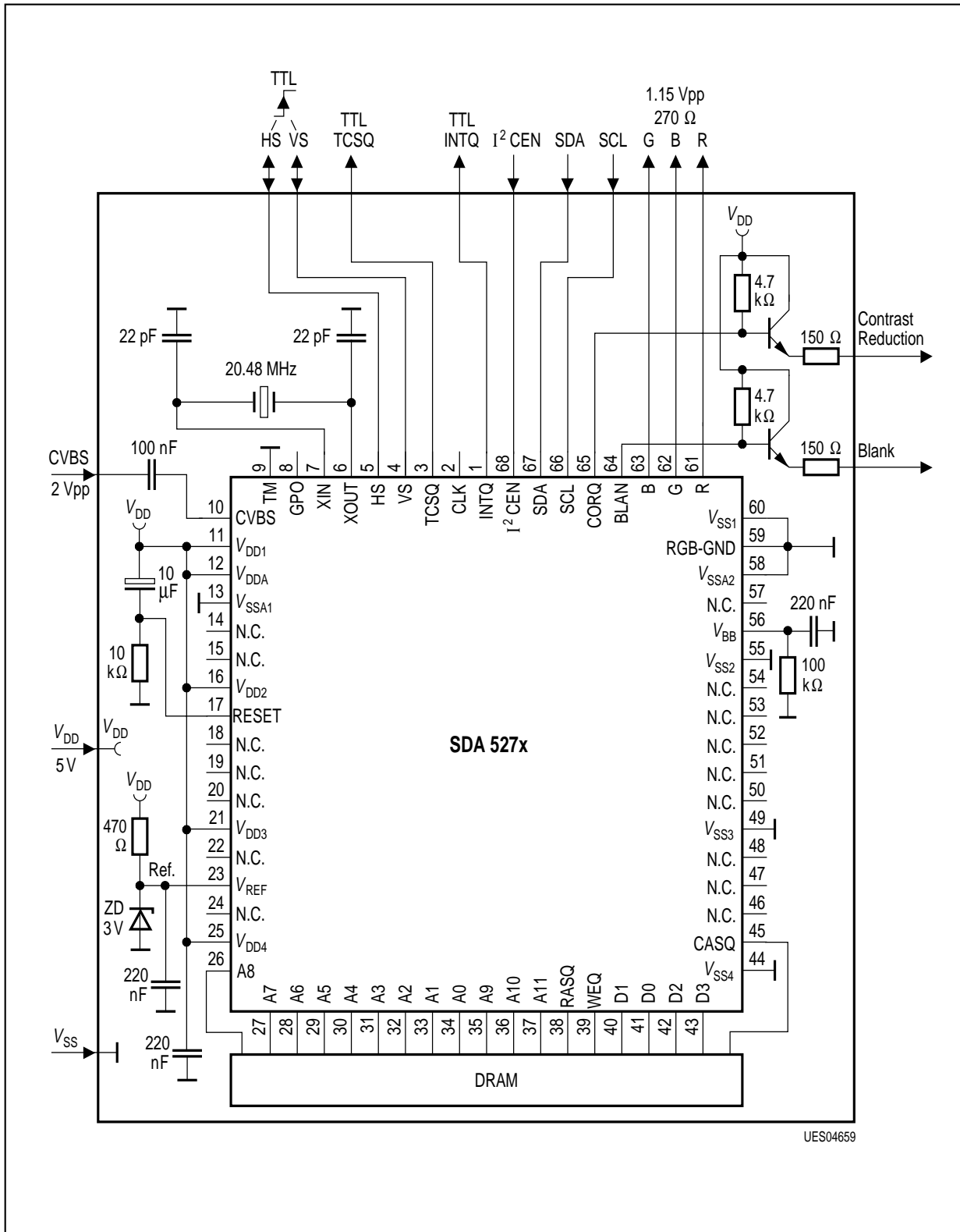

Application Circuit

4 Package Outlines

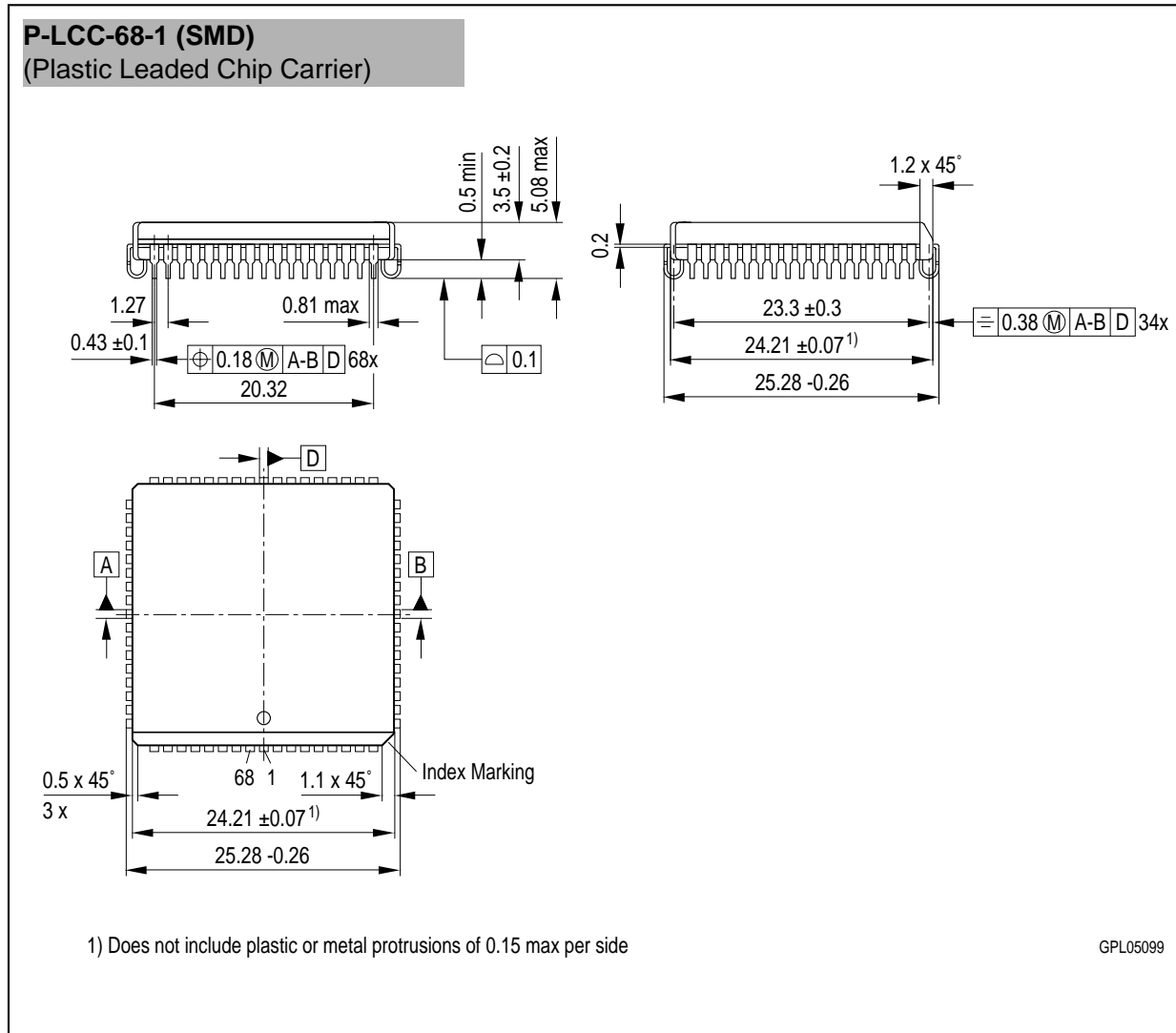

Sorts of Packing

Package outlines for tubes, trays etc. are contained in our Data Book "Package Information".

SMD = Surface Mounted Device

Dimensions in mm

Plastic Package, P-SDIP-52-1
(Plastic Dual In-Line Package)

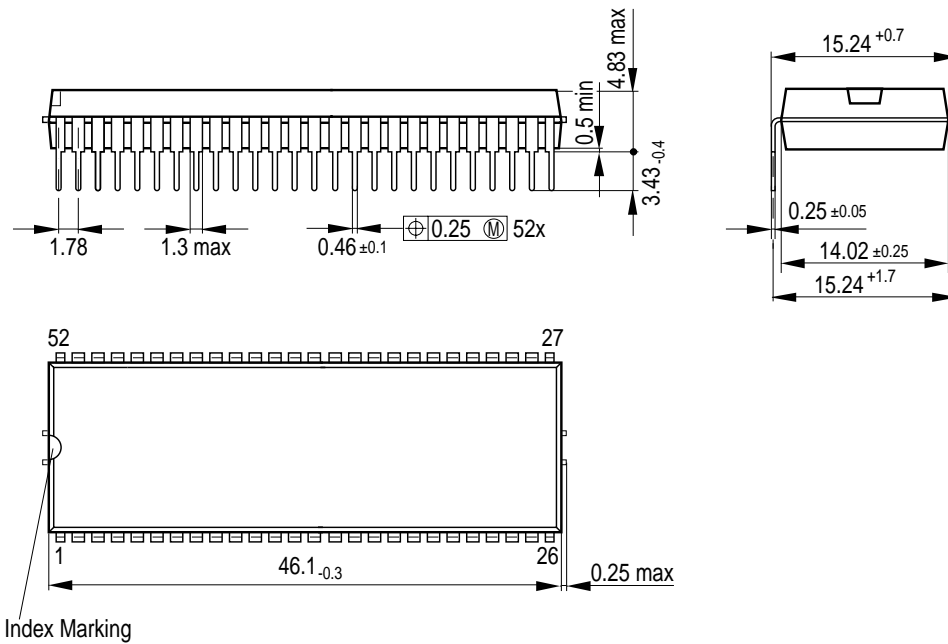

GPD05262

Sorts of Packing

Package outlines for tubes, trays etc. are contained in our Data Book "Package Information".

SMD = Surface Mounted Device

Dimensions in mm