

STEERING DIODE/TVS ARRAY COMBO

APPLICATIONS

- ✓ Ethernet - 10/100 Base T
- ✓ FireWire
- ✓ Wireless Communications
- ✓ USB Interface

IEC COMPATIBILITY (EN61000-4)

- ✓ 61000-4-2 (ESD): Air - 15kV, Contact - 8kV
- ✓ 61000-4-4 (EFT): 40A - 5/50ns
- ✓ 61000-4-5 (Surge): 24A, 8/20 μ s - Level 2(Line-Gnd) & Level 3(Line-Line)

FEATURES

- ✓ 500 Watts Peak Power per Line (tp = 8/20 μ s)
- ✓ ESD Protection > 25 kilovolts
- ✓ Low Clamping Voltage
- ✓ Unidirectional Configuration
- ✓ Protects 2 I/O Ports & Power Supply
- ✓ Low Capacitance: 10pF
- ✓ RoHS Compliant in Lead-Free Versions

MECHANICAL CHARACTERISTICS

- ✓ Molded JEDEC SOT-143
- ✓ Weight 9 milligrams (Approximate)
- ✓ Available in Lead-Free Pure-Tin Plating(Annealed)
- ✓ Solder Reflow Temperature:
Pure-Tin - Sn, 100: 260-270°C
- ✓ Consult Factory for Leaded Device Availability
- ✓ Flammability Rating UL 94V-0
- ✓ 8mm Tape and Reel Per EIA Standard 481
- ✓ Marking: Marking Code



PIN CONFIGURATION

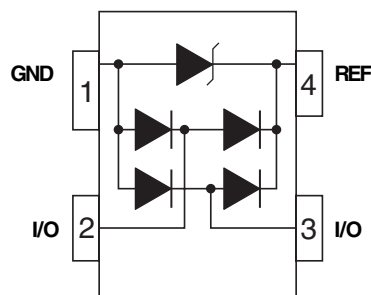

DEVICE CHARACTERISTICS

MAXIMUM RATINGS @ 25°C Unless Otherwise Specified

PARAMETER	SYMBOL	VALUE	UNITS
Peak Pulse Power (tp = 8/20µs) - See Figure 1	P _{PP}	500	Watts
Operating Temperature	T _L	-55 to 150	°C
Storage Temperature	T _{STG}	-55 to 150	°C
Peak Forward Voltage - I _F = 1A, 8/20µs	V _F	1.5	Volts

ELECTRICAL CHARACTERISTICS PER LINE @ 25°C Unless Otherwise Specified

PART NUMBER	DEVICE MARKING	RATED STAND-OFF VOLTAGE V _{WM} VOLTS	MINIMUM BREAKDOWN VOLTAGE @ 1mA V _(BR) VOLTS	MAXIMUM CLAMPING VOLTAGE (See Fig. 2) @ I _F = 1A V _C VOLTS	MAXIMUM CLAMPING VOLTAGE (See Fig. 2) 8/20µs V _C @ I _{PP} VOLTS	MAXIMUM LEAKAGE CURRENT @ V _{WM} I _b µA	MAXIMUM CAPACITANCE (See Note 1) (See Fig. 5) (Per Data Line) @ 0V, 1 MHz C _{J(SD)} pF
PSR05	5A	5.0	6.0	9.8	20.0V @ 28.0A	5.0	10

Note 1: As shown in Figure 5, REF 1 is connected to ground, REF 2 is connected to +V_{CC} and input applies to V_{CC} = 5V, V_{sign} = 30mV, F = 1MHz.

FIGURE 1
PEAK PULSE POWER VS PULSE TIME

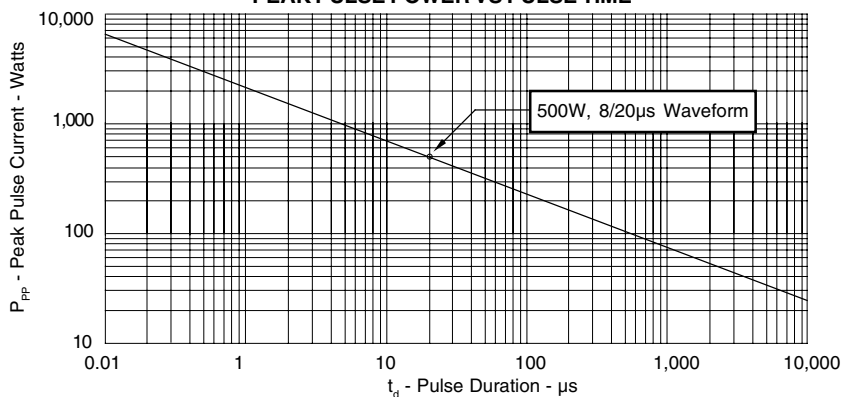
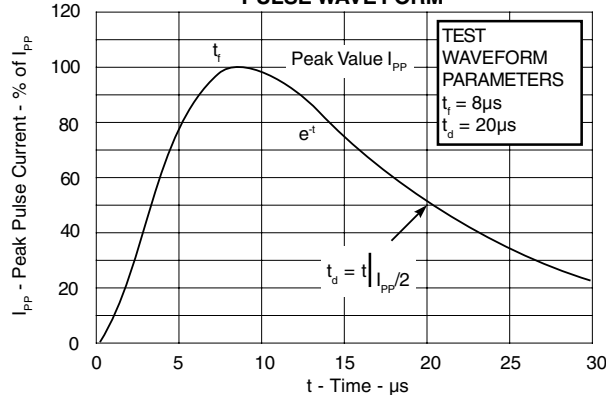

FIGURE 2
PULSE WAVE FORM



GRAPHS

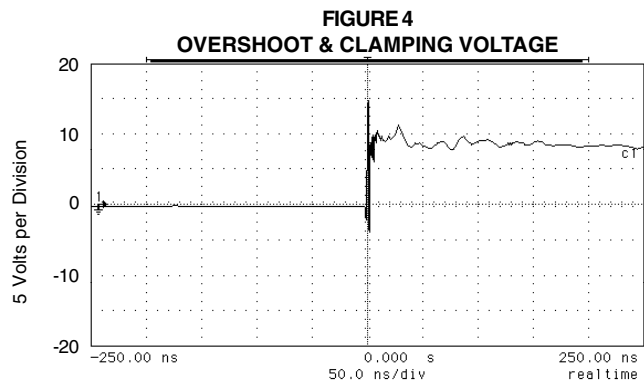
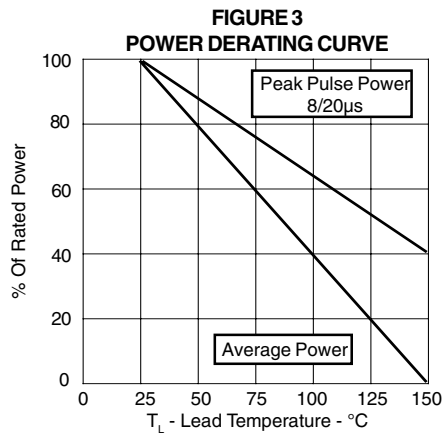
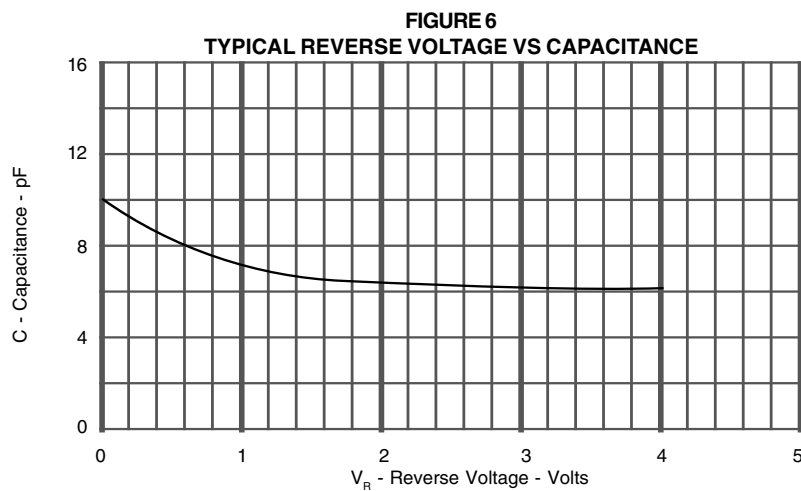
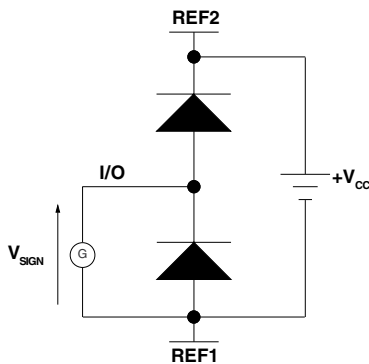

FIGURE 5
INPUT CAPACITANCE CIRCUIT



APPLICATION NOTE

The PSR05 is a low capacitance, bidirectional TVS array that is designed to protect I/O or high speed data lines from the damaging effects of ESD or EFT. This product series has a surge capability of 500 Watts P_{PP} per line for an 8/20 μ s waveform and offers ESD protection > 25kV.

COMMON-MODE CONFIGURATION (Figure 1)

Ideal for use in USB applications, two PSR05 devices provides up to two(2) lines of protection(per device) in a common-mode configuration as depicted in Figure 1.

Circuit connectivity is as follows:

- ✓ Pins 2 and 3 are connected to the datalines.
- ✓ Pin 1 is connected to ground.
- ✓ Pin 4 is connected to the databus.

CIRCUIT BOARD LAYOUT RECOMMENDATIONS

Circuit board layout is critical for Electromagnetic Compatibility (EMC) protection. The following guidelines are recommended:

- ✓ The protection device should be placed near the input terminals or connectors, the device will divert the transient current immediately before it can be coupled into the nearby traces.
- ✓ The path length between the TVS device and the protected line should be minimized.
- ✓ All conductive loops including power and ground loops should be minimized.
- ✓ The transient current return path to ground should be kept as short as possible to reduce parasitic inductance.
- ✓ Ground planes should be used whenever possible. For multilayer PCBs, use ground vias.

Figure 1. Typical Common-Mode USB Protection

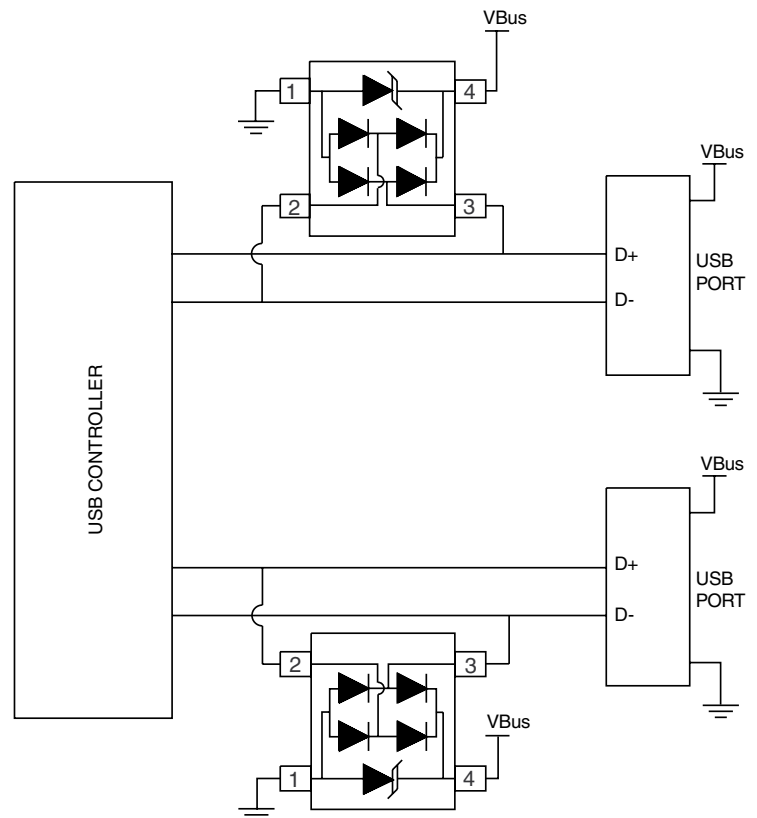

SOT-143 PACKAGE OUTLINE & DIMENSIONS

PACKAGE OUTLINE

SOT-143

PACKAGE DIMENSIONS

DIM	MILLIMETERS		INCHES	
	MIN	MAX	MIN	MAX
A	2.80	3.04	0.110	0.120
B	1.20	1.39	0.047	0.055
C	0.84	1.14	0.033	0.045
D	0.39	0.50	0.015	0.020
F	0.79	0.93	0.031	0.037
G	1.78	2.03	0.070	0.080
H	0.013	0.10	0.0005	0.004
J	0.08	0.15	0.003	0.006
K	0.46	0.60	0.018	0.024
L	0.445	0.60	0.0175	0.024
L1	0.40	0.60	0.016	0.024
R	0.72	0.83	0.028	0.033
S	2.11	2.48	0.083	0.098

MOUNTING PAD

TYPICAL		
DIM	Millimeters	Inches
X	1.2x0.9	0.047x0.035
Yx3	0.85x0.85	0.033x0.033
m	2.0	0.079
n	1.9	0.075

NOTES

1. Dimensioning and tolerances per ANSI Y14.5M, 1985.
2. Controlling Dimension: Inches
3. Dimensions are exclusive of mold flash and metal burrs.

TAPE & REEL ORDERING NOMENCLATURE

1. Surface mount product is taped and reeled in accordance with EIA-481.
2. Suffix-T7 = 7 Inch Reel - 3,000 pieces per 8mm tape, i.e., *PSR05-T7*.
3. Suffix-T13 = 13 Inch Reel - 10,000 pieces per 8mm tape, i.e., *PSR05-T13*.
4. Suffix - LF = Lead-Free, Pure-Tin Plating, i.e., *PSR05-LF-T7*.

Outline & Dimensions: Rev 3 - 3/08, 06011

Tape & Reel Specifications (Dimensions in millimeters)

Reel Dia.	Tape Width	A0	B0	K0	D	E	F	W	P0	P2	P	tmax
178mm (7")	8mm	3.10 ± 0.10	2.70 ± 0.10	1.35 ± 0.10	1.50 ± 0.10	1.75 ± 0.10	3.50 ± 0.05	8.00 ± 0.30	4.00 ± 0.10	2.00 ± 0.05	4.00 ± 0.10	0.25

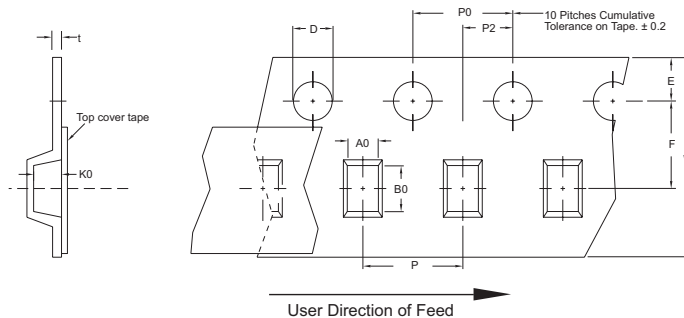

COPYRIGHT © ProTek Devices 2007

SPECIFICATIONS: ProTek reserves the right to change the electrical and or mechanical characteristics described herein without notice (except JEDEC).

DESIGN CHANGES: ProTek reserves the right to discontinue product lines without notice, and that the final judgement concerning selection and specifications is the buyer's and that in furnishing engineering and technical assistance, ProTek assumes no responsibility with respect to the selection or specifications of such products.

ProTek Devices
 2929 South Fair Lane, Tempe, AZ 85282
 Tel: 602-431-8101 Fax: 602-431-2288
 E-Mail: sales@protekdevices.com
 Web Site: www.protekdevices.com