

# Fluorescent display tube level meter driver, 16-point × 2 channel, VU scale, bar display

## BA6800AF

The BA6800AF is a two-channel, 16-point fluorescent display tube driver for VU-scale bar-level meters. It uses a dynamic-drive system and is provided with both AC and DC inputs. The AC input mode has a peak hold circuit. The IC features a power-on mute, and the output block can directly drive fluorescent display tubes, so few external components are required.

### ●Applications

Level meters for all types of AV equipment

### ●Features

- 1) Uses dynamic-drive system to display two 16-point channels. 28-pin SOP package.
- 2) AC and DC inputs provided. Switching function allows two-mode display.
- 3) Upper 12 points have peak hold function in AC mode (two seconds).
- 4) Power-on mute function.
- 5) Dynamic-drive system reduces the power dissipation of the fluorescent display tube power supply.
- 6) Square root compression amplifier built in.

●Block diagram

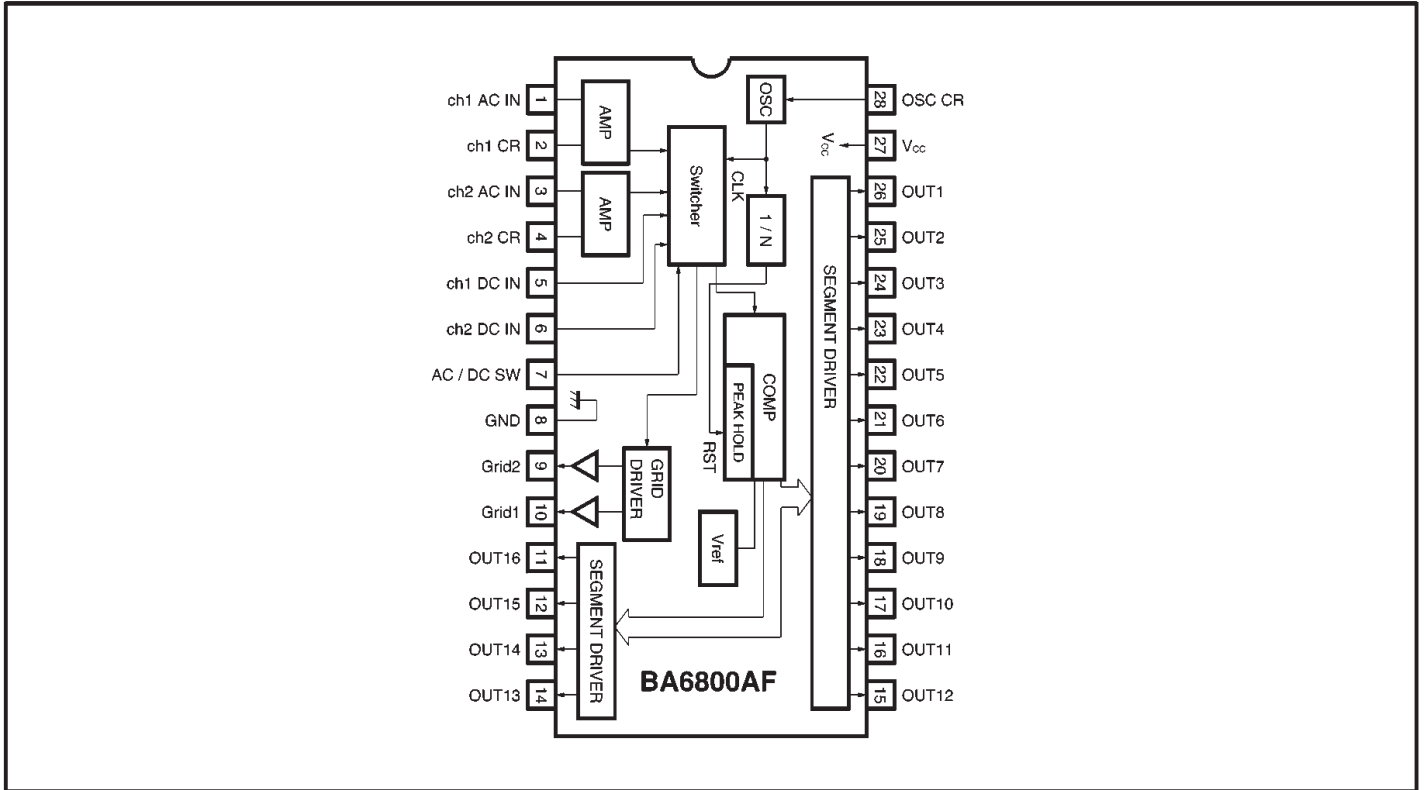

●Absolute maximum ratings (Ta = 25°C)

Parameter	Symbol	Limits	Unit
Power supply voltage	V <sub>CC</sub>	7.0	V
Power dissipation	P <sub>d</sub>	550*	mW
Operating temperature	T <sub>opr</sub>	-20~+70	°C
Storage temperature	T <sub>stg</sub>	-55~+125	°C
Output voltage	T <sub>CC1</sub> , +V <sub>EE</sub>	36	V

\* Reduced by 5.5mW for each increase in Ta of 1°C over 25°C.

●Electrical characteristics (unless otherwise noted, Ta = 25°C)

Parameter	Symbol	Min.	Typ.	Max.	Unit	Conditions
Operating voltage range	V <sub>CC</sub>	4.5	5.0	5.8	V	—
Quiescent current	I <sub>Q</sub>	—	17	24	mA	—
AC input resistance	R <sub>INAC</sub>	175	250	325	Ω	Pins 1 and 3
DC input resistance	R <sub>INDC</sub>	7	10	13	kΩ	—
Oscillator frequency	f <sub>OSC</sub>	1.7	2.0	2.3	kHz	C=0.015 μF, R=30kΩ
Peak hold time	T <sub>hold</sub>	—	2	—	s	f <sub>osc</sub> =2kHz
Output duty cycle	Duty	—	1 / 8	—	—	f <sub>osc</sub> =2kHz
Grid output low level voltage	V <sub>GL</sub>	—	0.4	0.8	V	I <sub>G</sub> =5mA
Grid output leakage current	I <sub>G leak</sub>	—	—	10	μA	V <sub>CC</sub> =5V

## ●Electrical characteristics (unless otherwise noted, Ta = 25°C)

Parameter	Symbol	Min.	Typ.	Max.	Unit	Conditions
Segment output high level voltage	V <sub>OH</sub>	3.7	4.0	—	V	I <sub>o</sub> =2mA
Segment output leakage current	I <sub>oleak</sub>	—	—	10	μA	−V <sub>EE</sub> =−31V
Input switching threshold	V <sub>TH</sub>	2.2	2.5	2.8	V	AC: pin 7 "H", DC: pin 7 "L"
AC sensitivity	V <sub>INAC</sub>	250	400	630	mV	R <sub>IN</sub> = 1.5kΩ AC comparator 10 on level
Maximum grid output current	I <sub>GM</sub>	5	—	—	mA	V <sub>OL</sub> =0.8V
Maximum segment output current	I <sub>OM</sub>	2	—	—	mA	V <sub>OH</sub> =3.7V
AC comparator level 16	V <sub>C16AC</sub>	8.5	10	12	dB	Pin 11 output
AC comparator level 15	V <sub>C15AC</sub>	6.0	7	8.5	dB	Pin 12 output
AC comparator level 14	V <sub>C14AC</sub>	4.0	5	6.0	dB	Pin 13 output
AC comparator level 13	V <sub>C13AC</sub>	2.5	3	4.0	dB	Pin 14 output
AC comparator level 12	V <sub>C12AC</sub>	1.5	2	2.5	dB	Pin 15 output
AC comparator level 11	V <sub>C11AC</sub>	0.5	1	1.5	dB	Pin 16 output
AC comparator level 10	V <sub>C10AC</sub>	—	0	—	dB	Pin 17 output
AC comparator level 9	V <sub>C9AC</sub>	−1.5	−1	−0.5	dB	Pin 18 output
AC comparator level 8	V <sub>C8AC</sub>	−2.5	−2	−1.5	dB	Pin 19 output
AC comparator level 7	V <sub>C7AC</sub>	−4.0	−3	−2.5	dB	Pin 20 output
AC comparator level 6	V <sub>C6AC</sub>	−6.0	−5	−4.0	dB	Pin 21 output
AC comparator level 5	V <sub>C5AC</sub>	−8.5	−7	−6.0	dB	Pin 22 output
AC comparator level 4	V <sub>C4AC</sub>	−15	−10	−8.5	dB	Pin 23 output
AC comparator level 3	V <sub>C3AC</sub>	−25	−20	−15	dB	Pin 24 output
AC comparator level 2	V <sub>C2AC</sub>	−35	−30	−25	dB	Pin 25 output
AC comparator level 1	V <sub>C1AC</sub>	−55	−40	−35	dB	Pin 26 output
DC comparator level 16	V <sub>C16DC</sub>	2.76	3.10	3.44	V	Pin 11 output
DC comparator level 15	V <sub>C15DC</sub>	2.35	2.64	2.93	V	Pin 12 output
DC comparator level 14	V <sub>C14DC</sub>	2.07	2.33	2.59	V	Pin 13 output
DC comparator level 13	V <sub>C13DC</sub>	1.86	2.10	2.34	V	Pin 14 output
DC comparator level 12	V <sub>C12DC</sub>	1.79	2.03	2.27	V	Pin 15 output
DC comparator level 11	V <sub>C11DC</sub>	1.62	1.88	2.14	V	Pin 16 output
DC comparator level 10	V <sub>C10DC</sub>	1.51	1.80	2.09	V	Pin 17 output
DC comparator level 9	V <sub>C9DC</sub>	1.40	1.71	2.02	V	Pin 18 output
DC comparator level 8	V <sub>C8DC</sub>	1.33	1.66	1.99	V	Pin 19 output
DC comparator level 7	V <sub>C7DC</sub>	1.23	1.58	1.93	V	Pin 20 output
DC comparator level 6	V <sub>C6DC</sub>	1.07	1.41	1.75	V	Pin 21 output
DC comparator level 5	V <sub>C5DC</sub>	0.93	1.26	1.59	V	Pin 22 output
DC comparator level 4	V <sub>C4DC</sub>	0.77	1.07	1.37	V	Pin 23 output
DC comparator level 3	V <sub>C3DC</sub>	0.42	0.60	0.78	V	Pin 24 output
DC comparator level 2	V <sub>C2DC</sub>	0.21	0.33	0.45	V	Pin 25 output
DC comparator level 1	V <sub>C1DC</sub>	0.11	0.18	0.25	V	Pin 26 output

Notes: (1) The value given above for AC comparator level is measured after 0dB point adjustment.

(2) DC comparator level V<sub>C(n)DC</sub> (Max.) > V<sub>C(n+1)DC</sub> (Min.), but when the nth comparator is off, the (n+1)th comparator is never on.

● Measurement circuit

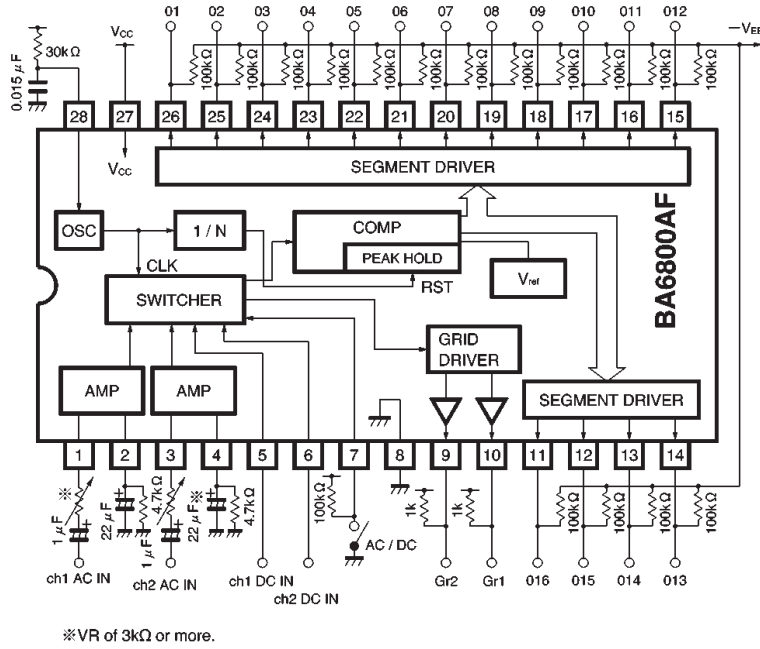

Fig. 1

● Application example

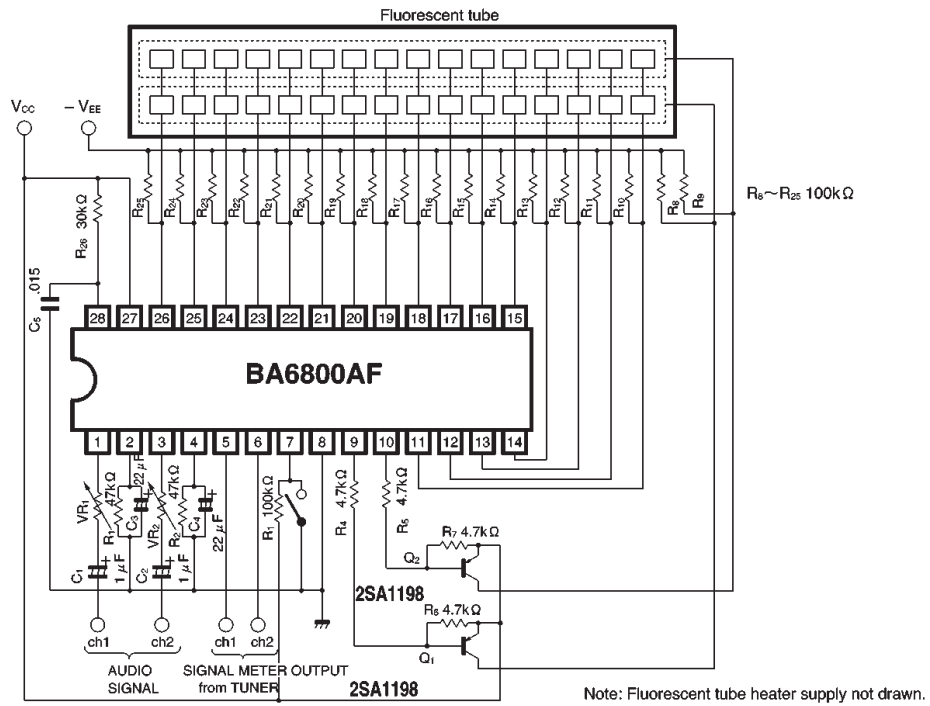

Fig. 2

●Circuit operation

(1) Input block

The AC input pins are pins 1 and 3, and the DC input pins are pins 5 and 6. Pin 7 is used to switch between the AC and DC inputs. When the input to pin 7 is "H", AC input is selected (pins 1 and 3). Therefore, by using pin 7 to switch between the AC and DC modes, the IC can do two jobs. For example, pins 1 and 3 can be used for audio signal input, and pins 5 and 6 can be used as the input for the signal meter output from a tuner (DC).

The AC input impedance of pins 1 and 3 is a low 250Ω (Typ.), so connect potentiometers (VR<sub>1</sub> and VR<sub>2</sub>) in series with the inputs to adjust the sensitivity and ch1 and ch2 balance.

(2) Peak hold circuit

The BA6800AF have peak hold circuits that temporarily holds peak signal levels in AC input mode.

The peak hold function can be used with the upper 12 points (5 to 16). The peak hold time depends on the oscillator frequency. It is 2 sec. (Typ.) for an oscillator frequency of 2kHz.

DC mode does not have a peak hold function.

(3) Grid output

The pin 9 and 10 grid outputs are open-collector NPN transistors. The logic is active low (the fluorescent tube lights when the output is "L"), so connect two PNP transistors Q<sub>1</sub> and Q<sub>2</sub> as shown in the application example circuit to drive the fluorescent tubes (see Fig. 3).

(4) Segment output block

Pins 11 to 26 are the segment outputs. The output circuits are open-collector PNP transistors. When grid 1 is "L", the ch1 level is output (pin 1 or 5 input level), and when grid 2 is "L", the ch2 level is output (pin 3 or 6 input level). Refer to Fig. 4.

(5) Grid and segment output timing chart. The grid and segment output timing for an oscillator frequency of 2kHz is shown in Fig. 5.

(6) Attack and release times

The response characteristic for AC input signals is set by resistor R<sub>1</sub> and capacitor C<sub>3</sub> for ch1 and resistor R<sub>2</sub> and capacitor C<sub>4</sub> for ch2 (pins 2 and 4). When R<sub>1</sub> = 47kΩ and C<sub>3</sub> = 22μF, the attack time is about 4ms, and the release time is about 1sec. (same for ch2).

Attack time : Time for the voltage on pins 2 and 4 to rise from 1V to 2.5V when the input goes from no input to 2.6Vrms, then back to no input.

Release time : Time for the voltage on pins 2 and 4 to fall from 2.5V to 1V when the input goes from 2.6Vrms to no input.

(7) Oscillator frequency

The resistor R<sub>26</sub> and capacitor C<sub>5</sub> connected to pin 28 determine the oscillator frequency.

The oscillator frequency (f<sub>osc</sub>) and grid output period (T) are related as follows :

$$T \text{ (ms)} = 16 / f_{\text{osc}} \text{ (kHz)}$$

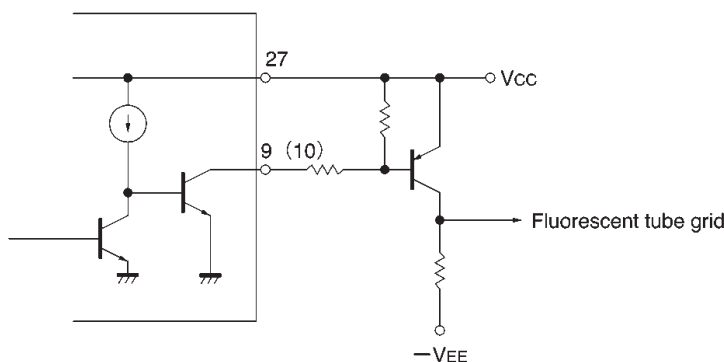
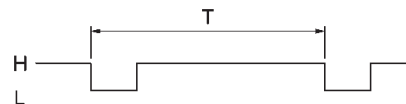

Fig. 3

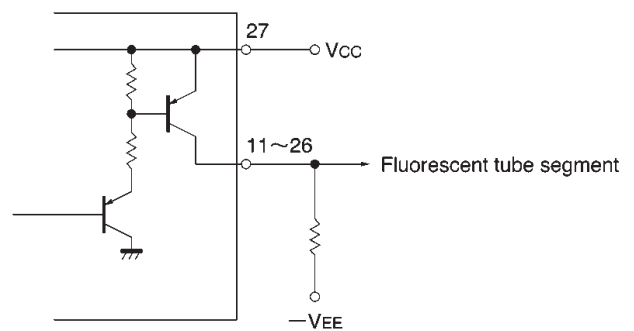

Fig. 4

●Timing chart

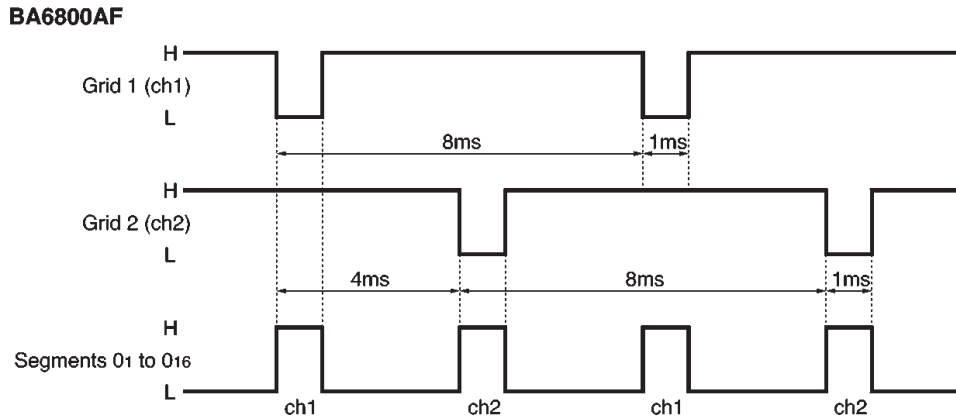

Fig. 5

●Attached components (refer to “Circuit operation”)

C<sub>1</sub> and C<sub>2</sub> : input coupling capacitors.

VR<sub>1</sub> and VR<sub>2</sub> : AC sensitivity adjustment and balance adjustment (3kΩ recommended).

C<sub>3</sub>, R<sub>1</sub>, C<sub>4</sub> and R<sub>2</sub> : set the response characteristics with respect to the AC input signal. In the example given, the attack time is about 4mS and the release time is about 1sec.

R<sub>3</sub> : Pullup resistor for the input switching terminal (pin 7).

R<sub>6</sub> and R<sub>7</sub> : resistor for the grid leak current path (I<sub>Gleak</sub>).

Set so that I<sub>Gleak</sub> × R<sub>6</sub> (R<sub>7</sub>) < 0.6V.

R<sub>4</sub> and R<sub>5</sub> : base bias resistors for Q<sub>1</sub> and Q<sub>2</sub>.

Conditions for base bias current (I<sub>B</sub>) flow are V<sub>CC</sub> = 5V and

V<sub>F</sub> = 0.6V :

$$\frac{R_4}{R_6} < \frac{5 - 0.6}{0.6} = 7.3$$

the base current is given by the following formula.

$$I_B \text{ (mA)} \doteq \frac{5 - 0.6}{R_4 \text{ (k}\Omega\text{)}} - \frac{0.6}{R_6 \text{ (k}\Omega\text{)}}$$

$$I_B > \frac{\text{Fluorescent tube grid current}}{h_{FE}}$$

Set resistors R<sub>4</sub> and R<sub>6</sub> (R<sub>5</sub> and R<sub>7</sub>) so that

Q<sub>1</sub> and Q<sub>2</sub> : grid output inverting transistors. Use transistors for which V<sub>CEO</sub> > V<sub>CC</sub> + V<sub>EE</sub>.

R<sub>8</sub> to R<sub>25</sub> : Resistors that reverse bias the segments and grid when the fluorescent tube is not lit.

The application example given is for general cases. Select the resistors to suit the characteristics of the fluorescent tube used.

C<sub>5</sub> and R<sub>26</sub> : set the oscillator frequency.

Capacitor C<sub>5</sub> should be a component with good temperature characteristics.

●Operation notes

(1) Adjust the potentiometers VR<sub>1</sub> and VR<sub>2</sub> (connected to pins 1 and 3) to adjust the 0dB input level and the dispersion of ch1 and ch2.

(2) The temperature characteristic for the lighting limit for the 16th LED is shown in Fig. 6.

(3) The external resistor R<sub>26</sub> connected to the oscillator (pin 28) should be in the range of 20kΩ and 100kΩ. If it is outside this range, oscillation may stop due to the influence of temperature (see Fig. 7).

●Electrical characteristics curves

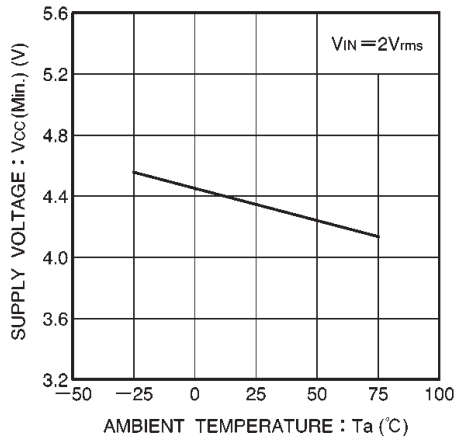

Fig. 6 16th point lighting limit supply voltage vs. ambient temperature

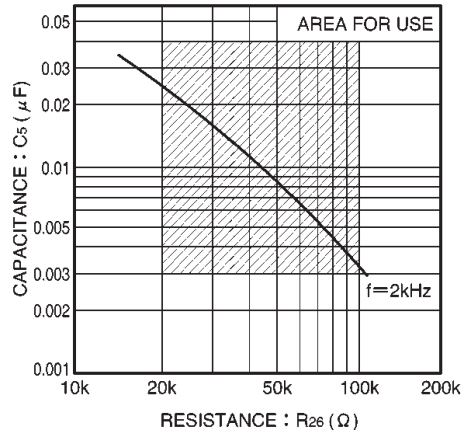

Fig. 7 Value of external components for oscillator (Vcc = 5.0V)

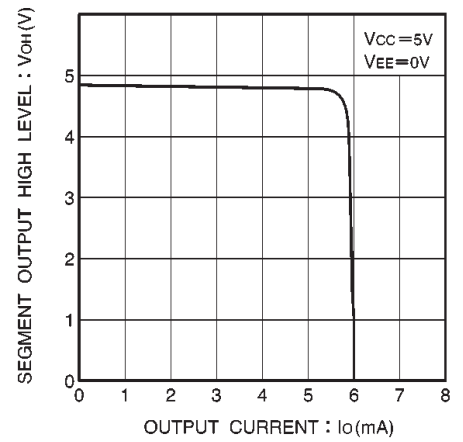

Fig. 8 Segment high level output vs. output current

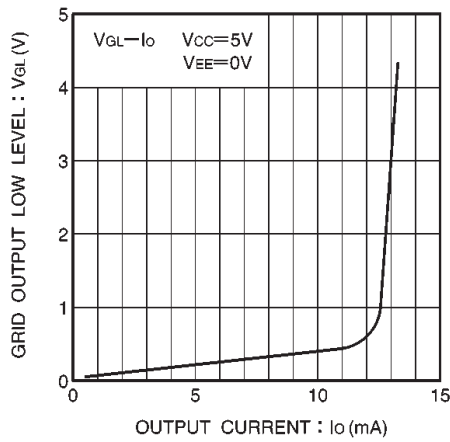

Fig. 9 Grid low level output vs. output current

●External dimensions (Units: mm)

