



**CRYSTEK**  
**CRYSTALS**  
A DIVISION OF CRYSTEK CORPORATION

**CCLD-034 5x7mm SMD  
LVDS Clock Oscillator  
3.3 Volts**



**Model CCLD-034 is a 162.000Mhz to 312.500MHz LVDS  
Clock Oscillator operating at 3.3Volts. The oscillator utilizes  
a High Q Third Overtone crystal design providing very low  
Jitter and Phase Noise. No Sub-Harmonics are present in  
the Output Signal.**



5x7mm SMD

### **Applications:**

**Digital Video  
SONET/SDH/DWDM  
Storage Area Networks  
Broadband Access  
Ethernet, Gigabit Ethernet**



12730 COMMONWEALTH DRIVE • FORT MYERS, FL 33913  
PHONE: 239-561-3311 • 800-237-3061  
FAX: 239-561-1025 • WWW.CRYSTEK.COM

Rev.: E  
Date: 10-10-07



# CRYSTEK

## CRYSTALS

A DIVISION OF CRYSTEK CORPORATION

### CCLD-034 5x7mm SMD LVDS Clock Oscillator



**Frequency Range:** 162.000Mhz to 312.500Mhz  
**Frequency Stability Options(ppm):** ±20, ±25, ±50, ±100

**Temperature Range: (standard)** 0°C to +70°C  
**(Option M)** -20°C to +70°C  
**(Option X)** -40°C to +85°C

**Storage:** -55°C to 120°C  
**Input Voltage:** 3.3V ± 0.3V  
**Input Current:** 45mA Typ., 66mA Max

**Output:** Differential LVDS  
**Symmetry:** 45/55% Max @ 50% Vdd  
**Rise/Fall Time:** 1nsec Max @ 20% to 80% Vdd

**Load:** 100 Ohms **Connected between OUT and COUT**

**Logic:** Output Voltage Levels  
**“0”=0.90 Min., 1.10 Typ.**  
**“1”=1.43 Typ., 1.60 Max**

**Differential Output Voltage:** 247mV Min., 454mV Max  
**Disable Time** 200nSec Max  
**Enable Time** 2mSec Max

**Phase Jitter:** 12KHz~80MHz **0.5psec Typ., 1psec RMS Max**

**Phase Noise:** (See Plot Below) **None**

**Sub-harmonics:** None  
**Aging:** <3ppm 1st/yr, <1ppm every year thereafter

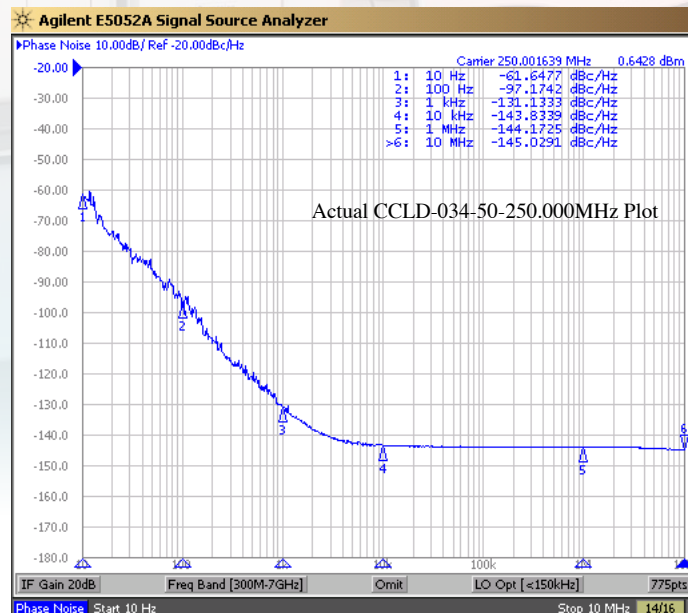



# CRYSTEK

## CRYSTALS

A DIVISION OF CRYSTEK CORPORATION

# CCLD-034 5x7mm SMD LVDS Clock Oscillator



### PART NUMBER GUIDE

CCLD - 034 X - 50 - 311.040

- #1 Crystek LVDS Osc.
- #2 Model 034
- #3 Temp. Range (Blank=0/70°C)(M=-20/70°C)(X=-40/85°C)
- #4 Stability: (see Table 1)
- #5 Frequency in MHz: 3 or 6 decimal places

Example:

CCLD-034X-50-311.040

3.3V, -40/85°C, ±50ppm, 311.0400 MHz

### Stability Indicator

Blank(std)	±100ppm
50	±50ppm
25	±25ppm
20	±20ppm

**Table 1**

### Standard Values

- (±50ppm, 0/70°C)
- 200.000MHz
- 212.500MHz
- 250.000MHz
- 311.040MHz
- 312.500MHz

### Mechanical:

- Shock:** MIL-STD-883, Method 2002, Condition B
- Solderability:** MIL-STD-883, Method 2003
- Vibration:** MIL-STD-883, Method 2007, Condition A
- Solvent Resistance:** MIL-STD-202, Method 215
- Resistance to Soldering Heat:** MIL-STD-202, Method 210, Condition I or J

### Environmental:

- Thermal Shock:** MIL-STD-883, Method 1011, Condition A
- Moisture Resistance:** MIL-STD-883, Method 1004

### RECOMMENDED REFLOW SOLDERING PROFILE

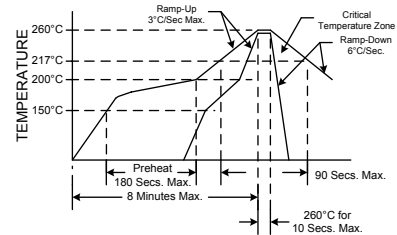

0.274 ±0.007  
(6.96 ±0.18)

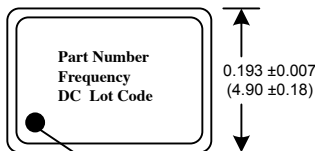

Denotes pad 1

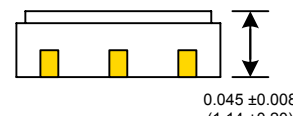
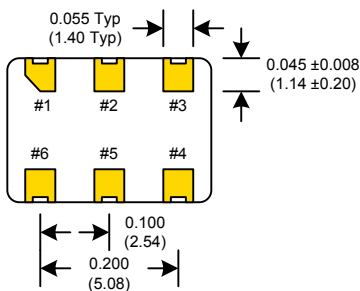

### SUGGESTED PAD LAYOUT

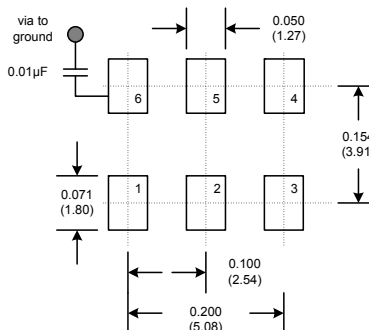

### Tri-State Function

Pin #1 State	Output State
Open or N/C	Active
"1" level 0.7*Vcc Min	Active
"0" level 0.3*Vcc Max	High Z

Pad	Connection
1	Enable/Disable
2	N/C
3	GND
4	Out
5	Comp. Out
6	VCC