

Features
•Combination of 1 DPDT and 2 SPDT switches

- Low Insertion Loss** : 1.30 dB @ 2.50 GHz
1.55 dB @ 5.85 GHz

- **Isolation**: 26 dB @ 2.50 GHz
19 dB @ 5.85 GHz

- **Miniature QFN16L (4x4 mm) Plastic Lead (Pb) Free Package**

- **PHEMT process**

- **Lead Free and RoHS (Restrict of Hazardous Substances) Compliant Version of HWS379**

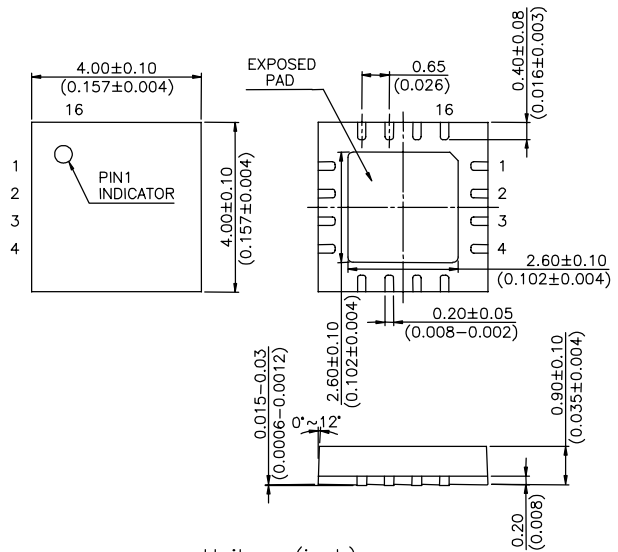
QFN16L (4 x 4 mm)

Description

The HWS454 is a GaAs PHEMT MMIC DP4T switch operating at 0.5-6 GHz in a low cost miniature QFN16L (4 x 4 mm) plastic lead (Pb) free package. The HWS454 combines one DPDT switch and two SPDT switches in a single IC and features low insertion loss and high isolation with very low DC power consumption. This switch can be used in IEEE 802.11a/b/g WLAN or WiMAX systems for combination of transmit/receive and antenna diversity functions. Two antenna ports can be selected for antenna diversity function and four RF ports can be arbitrary chosen for 2.5 GHz band or 5.85 GHz band as transmit/receive functions.

Electrical Specifications at 25°C with 0, +3V Control Voltages

Parameter	Test Conditions	Min.	Typ.	Max.	Unit
Insertion Loss ANT ports to RF ports	0.50-6.00 GHz		1.60		dB
	2.40-2.50 GHz		1.30	1.50	dB
	5.15-5.85 GHz		1.55	1.85	dB
Isolation (SPDT part) Ex: ANT1 to RF2 when ANT1 to RF1 is on	0.50-6.00 GHz		25		dB
	2.40-2.50 GHz		26		dB
	5.15-5.85 GHz	24	27		dB
Isolation (DPDT part) Ex: ANT2 to RF1 when ANT1 to RF1 is on	0.50-6.00 GHz		19		dB
	2.40-2.50 GHz		27		dB
	5.15-5.85 GHz	16	19		dB
Return Loss	0.50-6.00 GHz		12		dB
Input Power for One dB Compression	2.00-6.00 GHz		30		dBm
Switching Time			70		nsec
Control Current			30	300	uA

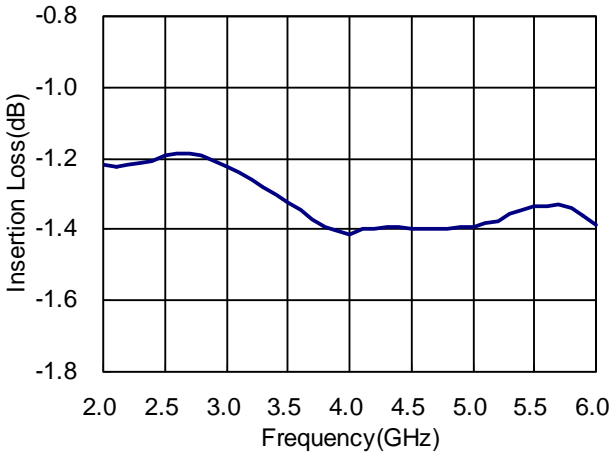
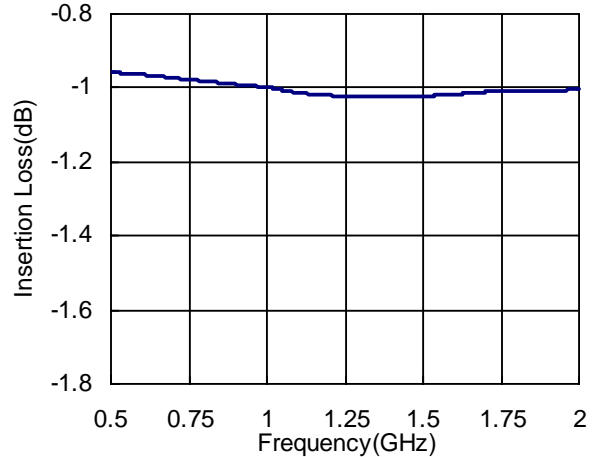
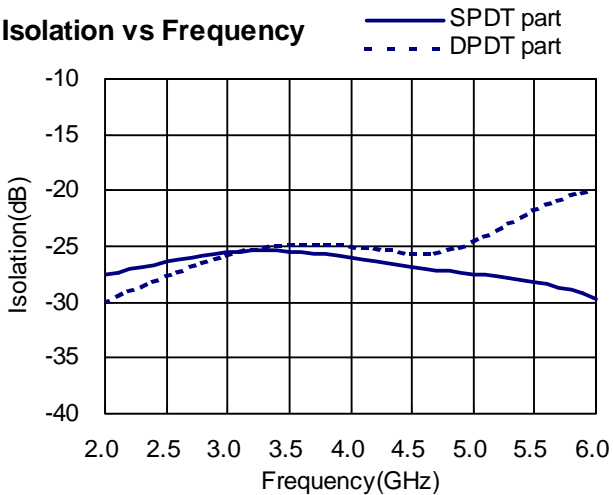
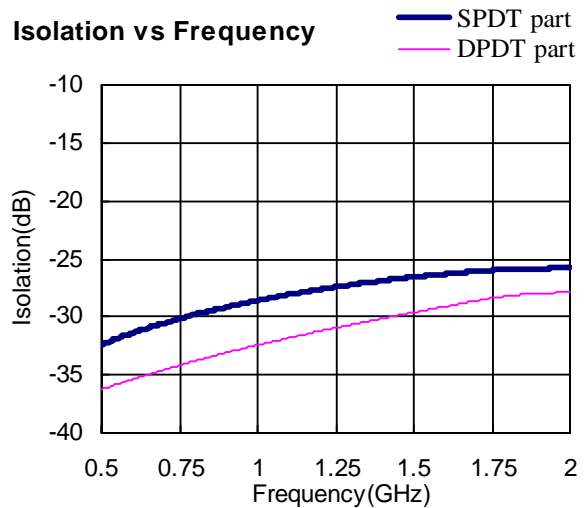
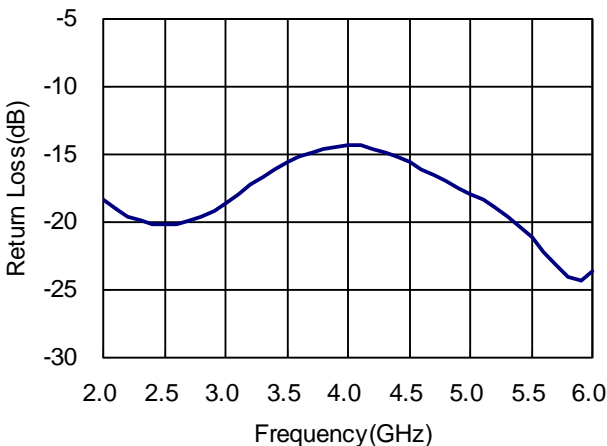
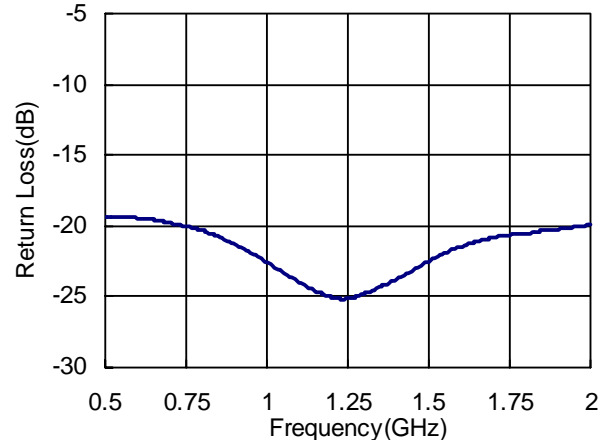
Note: All measurements made in a 50 ohm system with 0/+3.0V control voltages, unless otherwise specified.

Typical Performance Data with 8pF Capacitors @ +25°C
Insertion Loss vs Frequency

Typical Performance Data with 100pF Capacitors @ +25°C
Insertion Loss vs Frequency

Isolation vs Frequency

Isolation vs Frequency

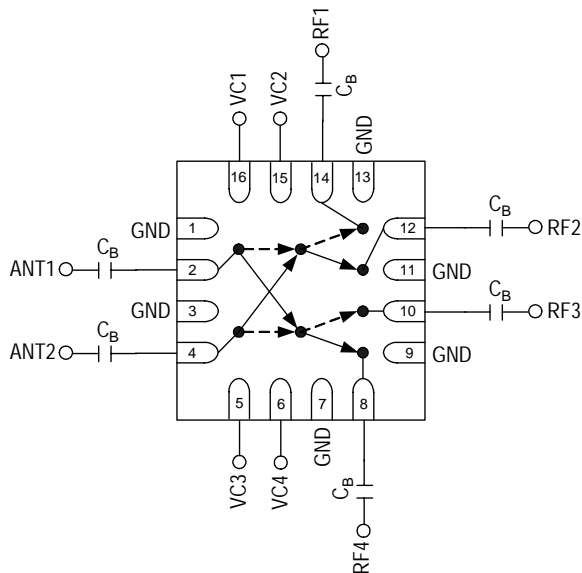
Return Loss vs Frequency

Return Loss vs Frequency

Absolute Maximum Ratings

Parameter	Absolute Maximum
RF Input Power	+32 dBm @ +3V
Control Voltage	+6V
Operating Temperature	-40°C to +85°C
Storage Temperature	-65°C to +150°C

Pin Out (Top View)



Note:

1. DC blocking capacitors $C_B=8\text{pF}$ are required at 2~6GHz on all RF ports
2. DC blocking capacitors $C_B=100\text{pF}$ are required at 0.5~2GHz on all RF ports.
3. Exposed pad in the bottom must be connected to ground by via holes.

Logic Table for Switch On-Path

VC1	VC3	VC2	VC4	ANT1	ANT2
0	1	1	0	RF1	RF3
1	0	1	0	RF3	RF1
0	1	0	1	RF2	RF4
1	0	0	1	RF4	RF2

'1' = +3V to +5V

'0' = 0V to +0.2V

Application Information

Simplified Application Block Diagram Between HWS454 and WLAN 802.11 a/b/g RFIC

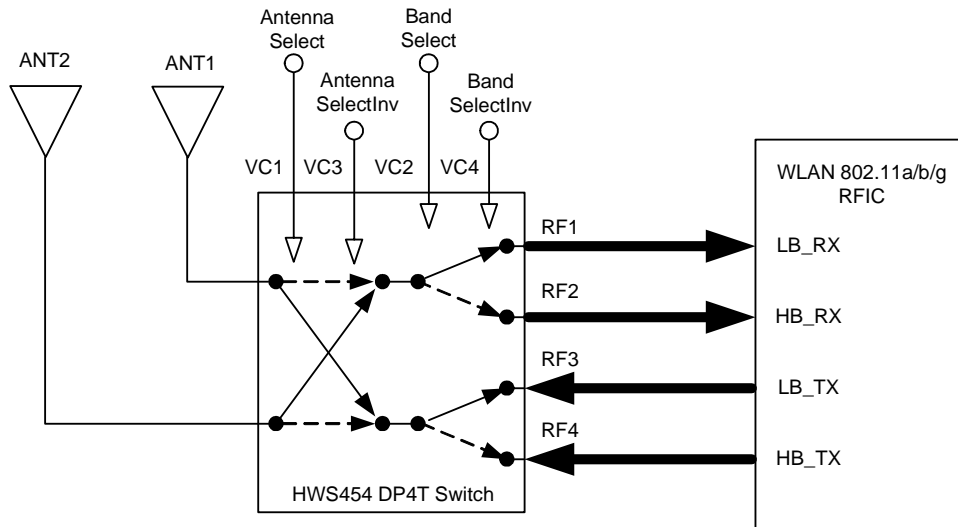

Note:

1. VC1 and VC3 are used for antenna selection, while VC2 and VC4 are used for band selection.
2. LB_RX stands for low-band(2.5 GHz band) receiving port and HB_TX stands for high-band(5.85 GHz band) transmitting port.
3. RF paths between switch and RFIC may include amplifiers, filters, and baluns.

Logic Table for Switch On-Path

VC1 (AntennaSelect)	VC3 (AntennaSelectInv)	VC2 (BandSelect)	VC4 (BandSelectInv)	ANT1	ANT2
0	1	1	0	RF1(LB_RX)	RF3(LB_TX)
1	0	1	0	RF3(LB_TX)	RF1(LB_RX)
0	1	0	1	RF2(HB_RX)	RF4(HB_TX)
1	0	0	1	RF4(HB_TX)	RF2(HB_RX)

Application Information (Continued)

Simplified Application Block Diagram Between HWS454 and WLAN 802.11 a/b/g RFIC

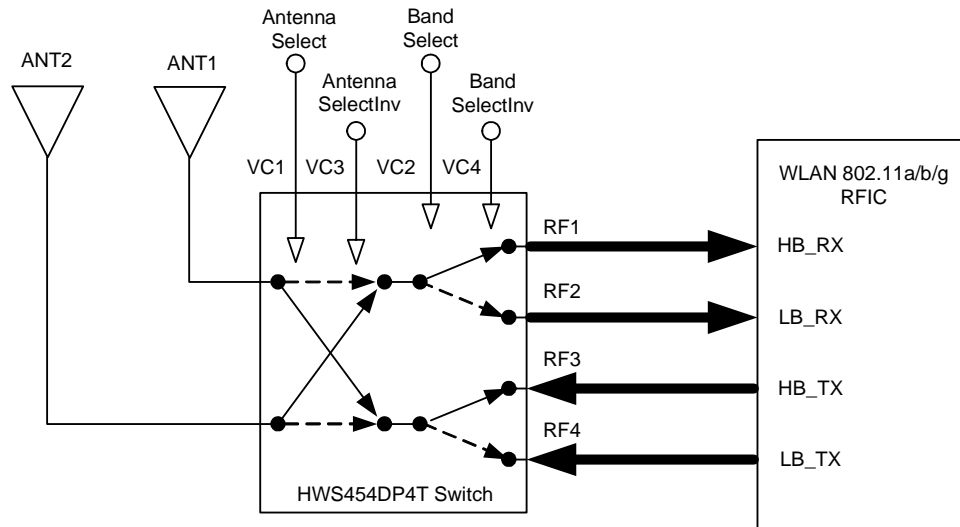

Note:

1. VC1 and VC3 are used for antenna selection, while VC2 and VC4 are used for band selection.
2. LB_RX stands for low-band(2.5 GHz band) receiving port and HB_TX stands for high-band(5.85 GHz band) transmitting port.
3. RF paths between switch and RFIC may include amplifiers, filters, and baluns.

Logic Table for Switch On-Path

VC1 (AntennaSelect)	VC3 (AntennaSelectInv)	VC2 (BandSelect)	VC4 (BandSelectInv)	ANT1	ANT2
0	1	1	0	RF1(HB_RX)	RF3(HB_TX)
1	0	1	0	RF3(HB_TX)	RF1(HB_RX)
0	1	0	1	RF2(LB_RX)	RF4(LB_TX)
1	0	0	1	RF4(LB_TX)	RF2(LB_RX)