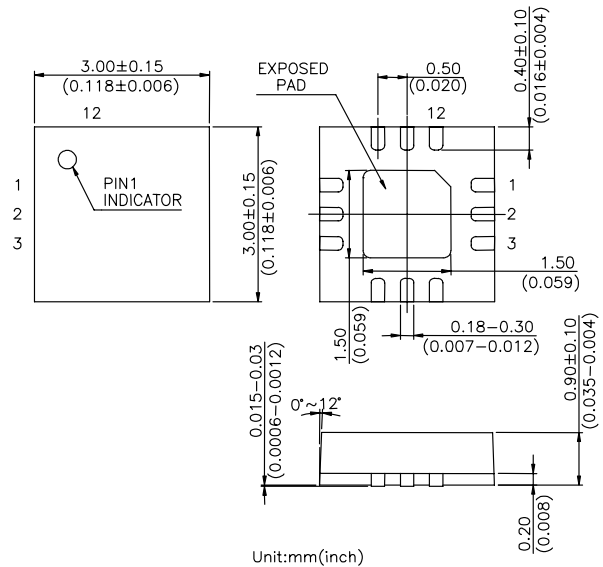

Features

- **Low Insertion Loss** : 0.50 dB @ 2.7 GHz
0.65 dB @ 5.8 GHz
- **Isolation**: 25.5 dB @ 2.7 GHz
27.5 dB @ 5.8 GHz
- **Low DC Power Consumption**
- **Miniature QFN12L (3x3 mm) Plastic Lead (Pb) Free Package, RoHS Compliant**
- **PHEMT process**

QFN12L (3 x 3 mm)

Description

The HWS450 is a GaAs PHEMT MMIC SPDT switch operating at 0.5-6 GHz in a low cost miniature QFN12L (3 x 3 mm) plastic lead (Pb) free package. The HWS450 features low insertion loss and high isolation with very low DC power consumption. This switch can be used in WiMAX or IEEE 802.11a/b/g WLAN PC card and access point applications as transmit/receive switch, antenna diversity switch, or band-selection switch.

Electrical Specifications at 25°C with 0, +3V Control Voltages

Parameter	Test Conditions	Min.	Typ.	Max.	Unit
Insertion Loss	0.50-6.00 GHz		0.65		dB
	2.30-2.70 GHz		0.50	0.70	dB
	3.30-3.90 GHz		0.55	0.75	dB
	5.15-5.88 GHz		0.65	1.00	dB
Isolation	0.50-6.00 GHz		25.0		dB
	2.30-2.70 GHz	20.0	25.5		dB
	3.30-3.90 GHz	20.0	25.0		dB
	5.15-5.88 GHz	22.0	27.5		dB
Return Loss	0.50-6.00 GHz		15		dB
Input Power for 0.1 dB Compression	2.00-6.00 GHz @+3V		33		dBm
	2.00-6.00 GHz @+5V		37		dBm
Second Harmonic	Pin=20 dBm		-75		dBc
Third Harmonic	Pin=20 dBm		-75		dBc
Input Third Order Intermodulation Intercept Point	25 dBm Per Tone, 3.80 GHz @+3V @+5V		57		dBm
			60		dBm
Switching Time	Rise, Fall (10/90% or 90/10% RF)		100	300	ns
Control Current	@+3V		5	50	uA

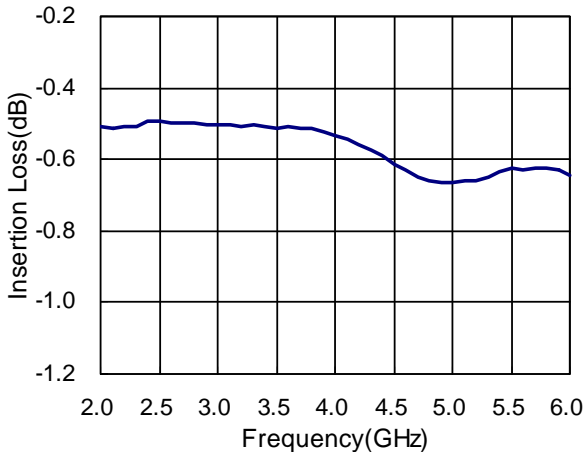
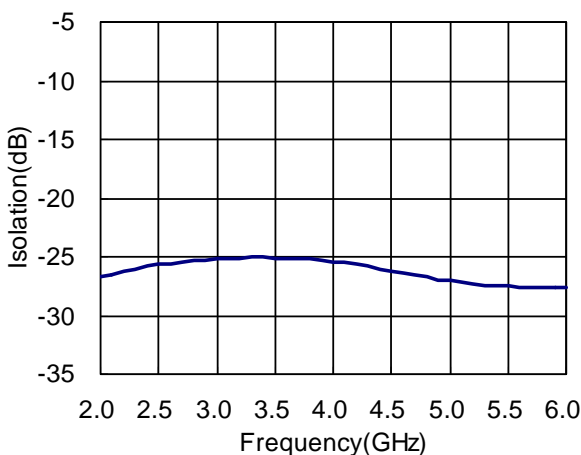
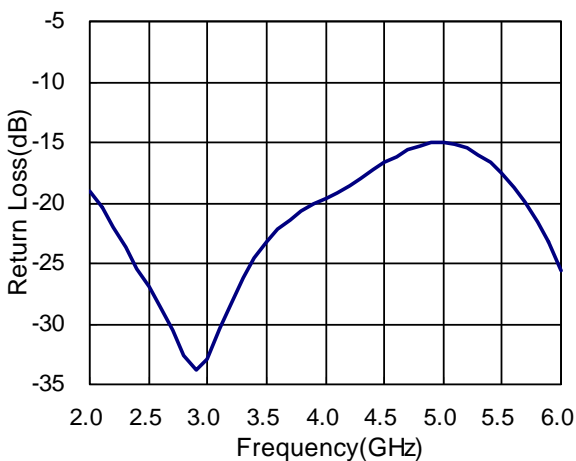
Note: All measurements made in a 50 ohm system with 0/+3.0V control voltages, unless otherwise specified.

Typical Performance Data with 8pF Capacitors @ +25°C
Insertion Loss vs Frequency

Isolation vs Frequency

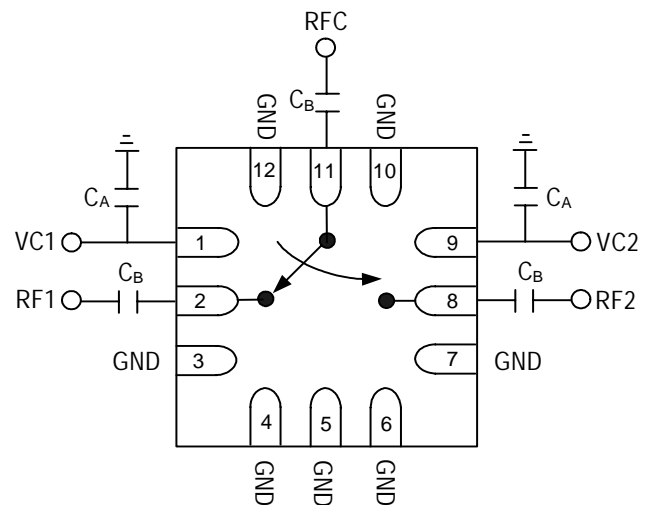
Return Loss vs Frequency

Absolute Maximum Ratings

Parameter	Absolute Maximum
RF Input Power	+36 dBm @ +3V
Control Voltage	+6V
Operating Temperature	-40°C to +85°C
Storage Temperature	-65°C to +150°C
Electrostatic Discharge Machine Model	Class M1

Pin Out (Top View)

Note:

- DC blocking capacitors $C_B=8\text{pF}$ are required on all RF ports.
- RF by-pass capacitors $C_A=8\text{pF}$.
- Exposed pad in the bottom must be connected to ground by via holes.

Logic Table for Switch On-Path

VC1	VC2	RF1-RFC	RF2-RFC
1	0	On	Off
0	1	Off	On

'1' = +3V to +5V
'0' = 0V to +0.2V