

August 1996

DTMF Tone Generator

Features

- Wide Operating Supply Voltage Range: 2.5 to 10 Volts
- Low Power CMOS Circuitry Allows Device Power to be Derived Directly from the Telephone Lines or from Small Batteries, e.g., 9V
- Uses TV Crystal Standard (3.58MHz) to Derive all Frequencies thus Providing Very High Accuracy and Stability
- Mute Drivers On-Chip
- Interfaces Directly to a Standard Telephone Push-Button or Calculator Type X-Y Keyboard
- The Total Harmonic Distortion is Below Industry Specification
- Oscillator Resistor On Chip
- On-Chip Generation of a Reference Voltage to Assure Amplitude Stability of the Dual Tones Over the Operating Voltage and Temperature Range
- Single Tone as Well as Dual Tone Capability
- Two Options Available:
E: Mode Select
F: Chip Disable

General Description

The S2559 DTMF Generator is specifically designed to implement a dual tone telephone dialing system. The device can interface directly to a standard pushbutton

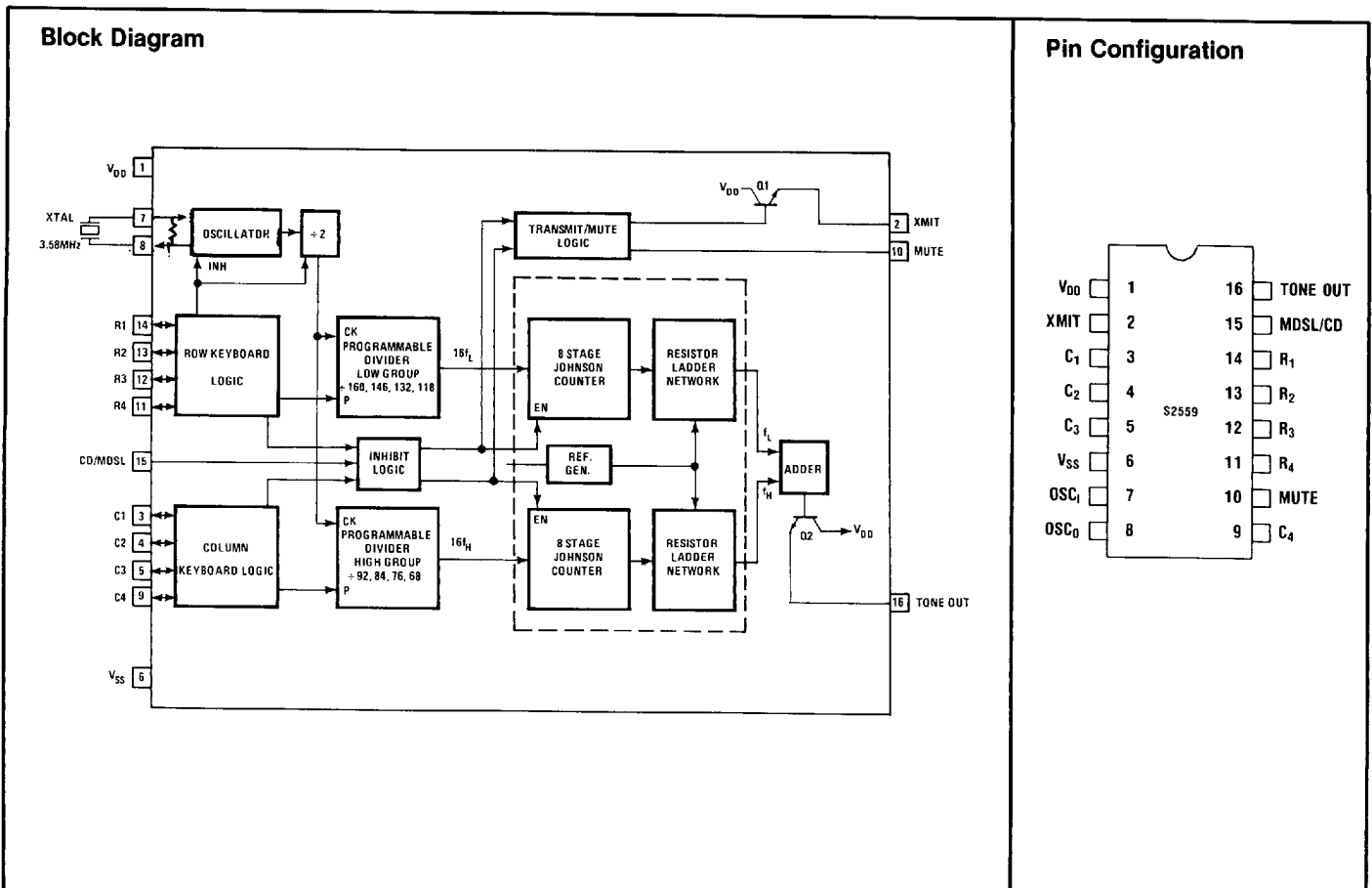

S2559E/F



DTMF Tone Generator

August 1996

General Description (Continued)

telephone keyboard or calculator type X-Y keyboard and operates directly from the telephone lines. All necessary dual-tone frequencies are derived from the widely used TV crystal standard providing very high accuracy and stability. The required sinusoidal waveform for the individual tones is digitally synthesized on the chip. The waveform so generated has very low total harmonic distortion. A voltage reference is generated on the chip which is stable over the operating voltage

and temperature range and regulates the signal levels of the dual tones to meet the recommended telephone industry specifications. These features permit the S2559 to be incorporated with a slight modification of the standard 500 type telephone basic circuitry to form a pushbutton dual-tone telephone. Other applications of the device include radio and mobile telephones, remote control, Point-of-Sale, and Credit Card Verification Terminals and process control.

Absolute Maximum Ratings

DC Supply Voltage ($V_{DD}-V_{SS}$)	+ 10.5V
Operating Temperature	Com-0°C to +70°C, Ind- -45°C to +85°C, Mil- -55° to +125°C
Storage Temperature	- 30°C to +125°C
Power Dissipation at 25°C	1000mW
Input	$V_{SS} - 0.3 \leq V_{IN} \leq V_{DD} + 0.3$

S2559E/F Electrical Characteristics:

Symbol	Parameter/Conditions			($V_{DD} - V_{SS}$) Volts	Min.	Typ.	Max.	Units
Supply Voltage								
V_{DD}	Tone Out Mode (Valid Key Depressed)				2.5		10.0	V
	NonTone Out Mode (No Key Depressed)				1.6		10.0	V
Supply Current								
I_{DD}	Standby (No Key Selected, Tone, XMIT and MUTE Outputs Unloaded)			3.0		0.3	30	μ A
				10.0		1.0	100	μ A
	Operating (One Key Selected, Tone, XMIT and MUTE Outputs Unloaded)			3.0		1.0	2.0	mA
				10.0		8	16.0	mA
ToneOutput								
S2559E/F	Single Tone	Row Tone,	$R_L = 390\Omega$	3.5	Com 335 Ind 255 Mil 235	465	Com 565 Ind 660 Mil 700	mVrms
	Mode Output			5.0	Com 380 Ind 300 Mil 250	540	710	mVrms
V_{OR}	Voltage	Row Tone,	$R_L = 240\Omega$	10.0	Com 380 Ind 300 Mil 250	550	735	mVrms
dBCR	Ratio of Column to Row Tone (Dual Tone Mode) 2559E/F			3.5 - 10.0	1.0	2.0	3.0	dB
%DIS	Distortion * 2559E/F			3.5 - 10.0			7	%

August 1996

DTMF Tone Generator

S2559E/F Electrical Characteristics: (continued)

Symbol	Parameter/Conditions	(V _{DD} -V _{SS}) Volts	Min.	Typ.	Max.	Units	
XMIT, MUTE Outputs							
V _{OH}	XMIT, Output Voltage, High (No Key Depressed)(Pin 2)	(I _{OH} = 15mA)	3.0	1.5	1.8	V	
		(I _{OH} = 50mA)	10.0	8.5	8.8	V	
I _{OF}	XMIT, Output Source Leakage Current, V _{OF} = 0V				100	μA	
V _{OL}	MUTE (Pin 10) Output Voltage, Low, (No Key Depressed), No Load		2.75		0	0.5	V
			10.0		0	0.5	V
V _{OH}	MUTE, Output Voltage, High, (One Key Depressed) No Load		2.75	2.5	2.75	V	
			10.0	9.5	10.0	V	
I _{OL}	MUTE, Output Sink Current	V _{OL} = 0.5V	3.0	0.53	1.3	mA	
			10.0	2.0	5.3	mA	
I _{OH}	MUTE, Output Source Current	V _{OH} = 2.5V	3.0	0.17	0.41	mA	
		V _{OH} = 9.5V	10.0	0.57	1.5	mA	

*Distortion is defined as "the ratio of the total power of all extraneous frequencies, in the VOICE and above 500Hz, to the total power of the DTMF frequency pair".

Table 1. Comparisons of Specified vs Actual Tone Frequencies Generated by S2559

ACTIVE INPUT	OUTPUT FREQUENCY Hz		% ERROR SEE NOTE
	SPECIFIED	ACTUAL	
R1	697	699.1	+0.30
R2	770	766.2	-0.49
R3	852	847.4	-0.54
R4	941	948.0	+0.74
C1	1,209	1,215.9	+0.57
C2	1,336	1,331.7	-0.32
C3	1,477	1,417.9	-0.35
C4	1,633	1,645.0	+0.73

NOTE: % Error does not include oscillator drift.

Table 2. XMIT and MUTE Output Functional Relationship

OUTPUT RELEASED	'DIGIT' KEY DEPRESSED	'DIGIT' KEY	COMMENT
XMIT	V _{DD}	High Impedance	Can source at least 50mA at 10V with 1.5V max. drop
MUTE	V _{SS}	V _{DD}	Can source or sink current

DTMF Tone Generator

August 1996

Figure 1. Standard Telephone Push Button Keyboard

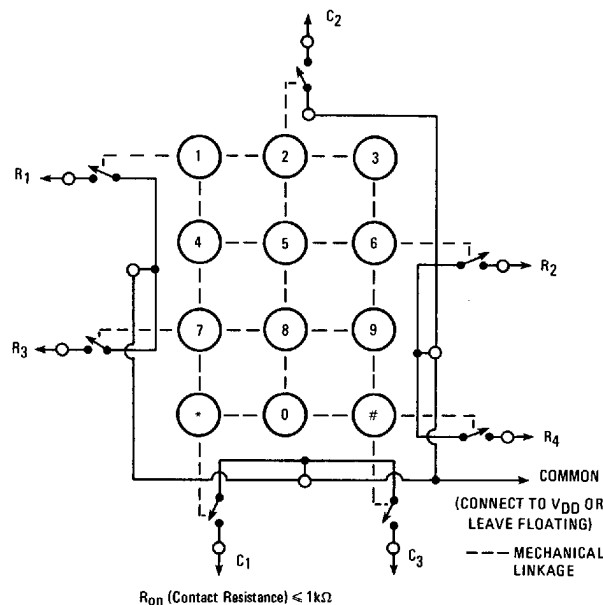

Circuit Description

The S2559 is designed so that it can be interfaced easily to the dual tone signaling telephone system and that it will more than adequately meet the recommended telephone industry specifications regarding the dual tone signaling scheme.

Design Objectives

The specifications that are important to the design of the DTMF Generator are summarized below: the dual tone signal consists of linear addition of two voice frequency signals. One of the two signals is selected from a group of frequencies called the "Low Group" and the other is selected from a group of frequencies called the "High Group". The low group consists of four frequencies 697, 770, 852 and 941 Hz. The high group consists of four frequencies 1209, 1336, 1477 and 1633 Hz. A keyboard arranged in a row, column format (4 rows x 3 or 4 columns) is used for number entry. When a push button corresponding to a digit (0 thru 9) is pushed, one appropriate row (R1 thru R4) and one appropriate column (C1 thru C4) is selected. The active row input selects one of the low group frequencies and the active column input selects one of the high group frequencies. In standard dual tone telephone systems, the

highest high group frequency of 1633Hz (Col. 4) is not used. The frequency tolerance must be $\pm 1.0\%$. However, the S2559 provides a better than .75% accuracy. The total harmonic and intermodulation distortion of the dual tone must be less than 10% as seen at the telephone terminals. (Ref. 1.) The high group to low group signal amplitude ratio should be $2.0 \pm 2\text{dB}$ and the absolute amplitude of the low group and high group tones must be within the allowed range. (Ref. 1.) These requirements apply when the telephone is used over a short loop or long loop and over the operating temperature range. The design of the S2559 takes into account these considerations.

Oscillator

The device contains an oscillator circuit with the necessary parasitic capacitances and feedback resistor on chip so that it is only necessary to connect a standard 3.58MHz TV crystal across the OSC_I and OSC_O terminals to implement the oscillator function. The oscillator functions whenever a row input is activated. The reference frequency is divided by 2 and then drives two sets of programmable dividers, the high group and the low group.

August 1996

DTMF Tone Generator

Keyboard Interface

The S2559 employs a calculator type scanning circuitry to determine key closures. When no key is depressed, active pull-down resistors are "on" on the row inputs and active pull-up resistors are "on" on the column inputs. When a key is pushed a high level is seen on one of the row inputs, the oscillator starts and the keyboard scan logic turns on. The active pull-up or pull-down resistors are selectively switched on and off as the keyboard scan logic determines the row and the column inputs that are selected. The advantage of the scanning technique is that a keyboard arrangement of SPST switches are shown in Figure 2 without the need

for a common line, can be used. Conventional telephone push button keyboards as shown in Figure 1 or X-Y keyboards with common can also be used. The common line of these keyboards can be left unconnected or wired "high".

Logic Interface

The S2559 can also interface with CMOS logic outputs directly. The S2559 requires active "High" logic levels. Since the active pull-up resistors present in the S2559 are fairly low value (500Ω typ), diodes can be used as shown in Figure 3 to eliminate excessive sink current flowing into the logic outputs in their "Low" state.

Figure 2. SPST Matrix Keyboard Arranged in the 2 of 8 Row, Column Format

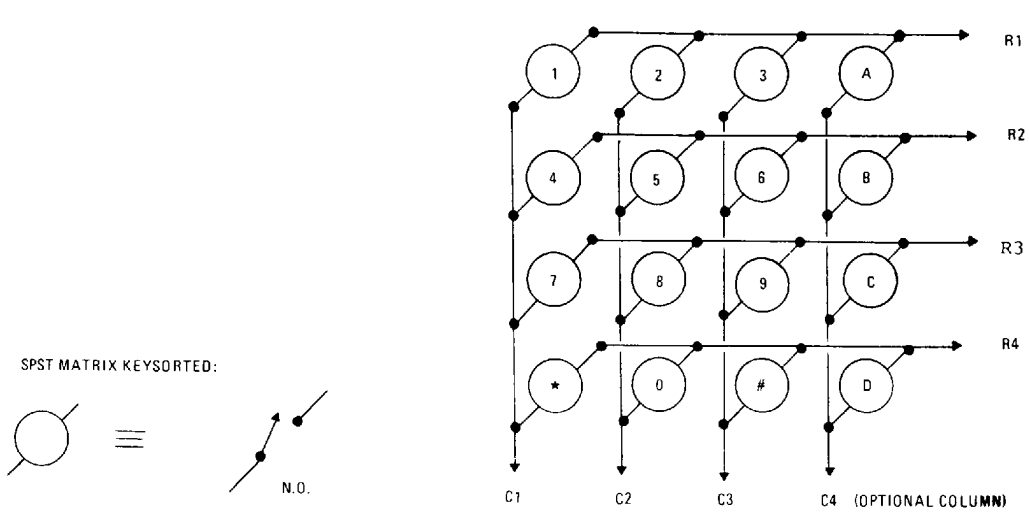

Tone Generation

When a valid key closure is detected, the keyboard logic programs the high and low group dividers with appropriate divider ratios so that the output of these dividers cycle at 16 times the desired high group and low group frequencies. The outputs of the programmable dividers drive two 8-stage Johnson counters. The symmetry of the clock input to the two divide by 16 Johnson counters allows 32 equal time segments to be generated within each output cycle. The 32 segments

are used to digitally synthesize a stair-step waveform to approximate the sinewave function (see Figure 3). This is done by connecting a weighted resistor ladder network between the outputs of the Johnson counter, V_{DD} and V_{REF} . V_{REF} closely tracks V_{DD} over the operating voltage and temperature range and therefore the peak-to-peak amplitude $V_P (V_{DD} - V_{REF})$ of the stairstep function is fairly constant. V_{REF} is so chosen that V_P falls within the allowed range of the high group and low group tones.

DTMF Tone Generator

August 1996

Figure 3. Logic Interface for Keyboard Inputs of the S2559

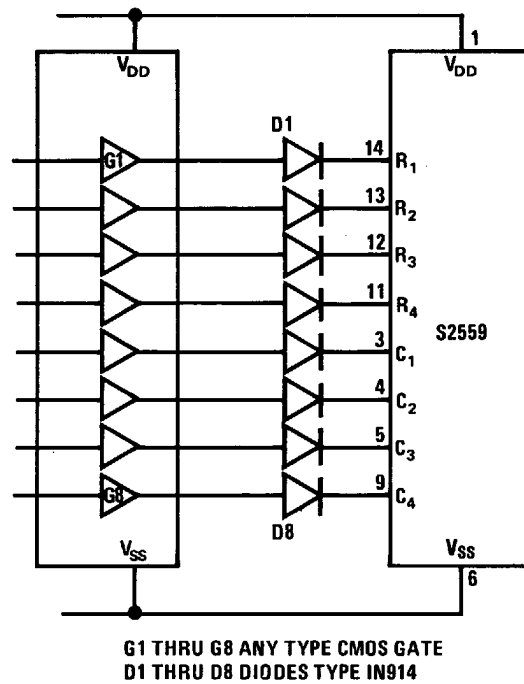
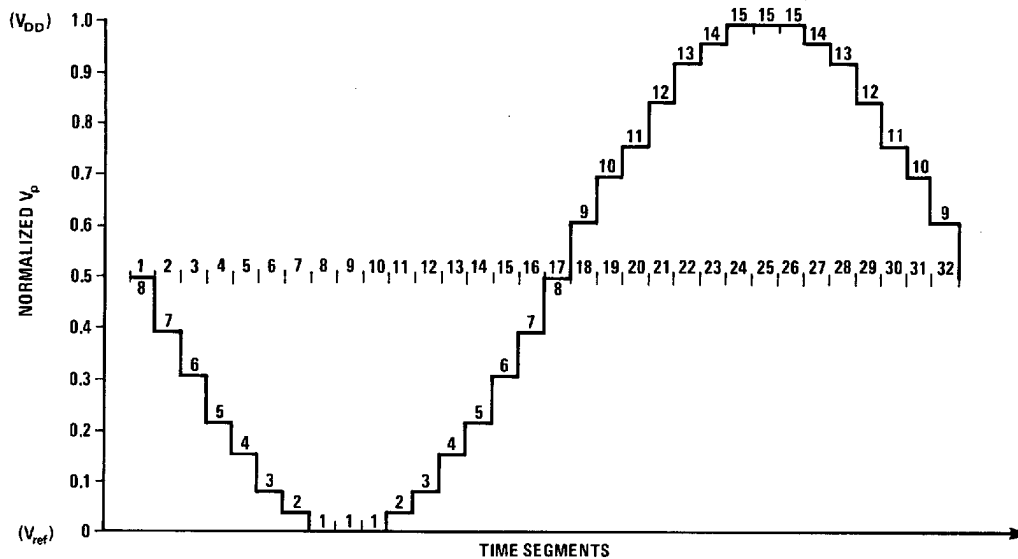

Figure 4. Stairstep Waveform of the Digitally Synthesized Sinewave



August 1996

DTMF Tone Generator

The individual tones generated by the sinewave synthesizer are then linearly added and drive a bipolar NPN transistor connected as emitter follower to allow proper impedance transformation, at the same time preserving signal level.

Dual Tone Mode

When one row and one column is selected dual tone output consisting of an appropriate low group and high group tone is generated. If two digit keys, that are not either in the same row or in the same column, are depressed, the dual tone mode is disabled and no output is provided.

Single Tone Mode

Single tones either in the low group or the high group can be generated as follows. A low group tone can be generated by activating the appropriate row input or by depressing two digit keys in the appropriate row. A high group tone can be generated by depressing two digit keys in the appropriate column, i.e., selecting the appropriate column input and two row inputs in that column.

Mode Select

The S2559E has a Mode Select (MDSL) input (Pin 15). When MDSL is left floating (unconnected) or connected to V_{DD} , both the dual tone and single tone modes are available. If MDSL is connected to V_{SS} , the single tone mode is disabled and no output tone is produced if an attempt for single tone is made. The S2559F does not have the Mode Select option.

Chip Disable

The S2559F has a Chip Disable input at Pin 15 instead of the Mode Select input. The chip disable for the S2559F is active "high." When the chip disable is active, the tone output goes to V_{SS} , the row, column inputs go into a high impedance state, the oscillator is inhibited and the MUTE and XMIT outputs go into active

states. The effect is the device essentially disconnects from the keyboard. This allows one keyboard to be shared among several devices. The CD pin has an internal pull-down.

MUTE, XMIT Outputs

The S2559E, F have a CMOS buffer for the MUTE output and a bipolar NPN transistor for the XMIT output. With no keys depressed, the MUTE output is "low" and the XMIT output is in the active state so that substantial current can be sourced to a load. When a key is depressed, the MUTE output goes high, while the XMIT output goes into a high impedance state. When Chip Disable is "high" the MUTE output is forced "low" and the XMIT output is in active state regardless of the state of the keyboard inputs.

Amplitude/Distortion Measurements

Amplitude and distortion are two important parameters in all applications of the Digital Tone Generator. Amplitude depends upon the operating supply voltage as well as the load resistance connected on the Tone Output pin. The on-chip reference circuit is fully operational when the supply voltage equals or exceeds 5 volts and as a consequence the tone amplitude is regulated in the supply voltage range above 5 volts. The load resistor value also controls the amplitude. If R_L is low the reflected impedance into the base of the output transistor is low and the tone output amplitude is lower. For R_L greater than $5k\Omega$ the reflected impedance is sufficiently large and highest amplitude is produced. Individual tone amplitudes can be measured by applying the dual tone signal to a wave analyzer (H-P type 3581A) and amplitudes at the selected frequencies can be noted. This measurement also permits verification of the preemphasis between the individual frequency tones.

Distortion is defined as "the ratio of the total power of all extraneous frequencies in the voiceband above 500Hz accompanying the signal to the power of the frequency pair." This ratio must be less than 10% or when expressed in dB must be lower than -20dB.

(Ref. 1.) Voiceband is conventionally the frequency band of 300Hz to 3400Hz. Mathematically distortion can be expressed as:

$$\text{Dist.} = \frac{\sqrt{(V_1)^2 + (V_2)^2 + \dots + (V_N)^2}}{\sqrt{(V_L)^2 + (V_H)^2}}$$

where $(V_1) \dots (V_N)$ are extraneous frequency (i.e., intermodulation and harmonic) components in the 500Hz to

Quartz Crystal Specification (25° C ± 2°C)	
Operating Temperature Range:	0°C to +70°C
Frequency	3.579545MHz
Frequency Calibration Tolerance	02 ± %
Load Capacitance	18pF
Effective Series Resistance	180 Ohms, max.
Drive Level-Correlation/Operating	2mW
Shunt Capacitance	7pF, max.
Oscillation Mode	Fundamental

DTMF Tone Generator

August 1996

3400Hz band and V_L and V_H are the individual frequency components of the DTMF signal. The expression can be expressed in dB as:

$$DIST_{dB} = 20 \log \frac{\sqrt{(V_1)^2 + (V_2)^2 + \dots + (V_N)^2}}{\sqrt{(V_L)^2 + (V_H)^2}}$$

$$= 10 \{ \log[(V_1)^2 + \dots + (V_N)^2] - \log[(V_L)^2 + (V_L)^2 + (V_H)^2] \} \dots (1)$$

An accurate way of measuring distortion is to plot a spectrum of the signal by using a spectrum analyzer (H-P type 3580A) and an X-Y plotter (H-P type 7046A). Individual extraneous and signal frequency components are then noted and distortion is calculated by using the expression (1) above. Figure 6 shows a spectrum plot of a typical signal obtained from a S2559 device operating from a fixed supply of 4Vdc and $R_L = 10k\Omega$ in the test circuit of Figure 5. Mathematical analysis of the spec-

trum shows distortion to be -30dB (3.2%). For quick estimate of distortion, a rule of thumb as outlined below can be used.

“As a first approximation distortion in dB equals the difference between the amplitude (dB) of the extraneous component that has the highest amplitude and the amplitude (dB) of the low frequency signal.” This rule of thumb would give an estimate of -28dB as distortion for the spectrum plot of Figure 6 which is close to the computed result of -30dB .

In a telephone application amplitude and distortion are affected by several factors that are interdependent.

Ref. 1: Bell System Communications Technical Reference, PUB 47001, “Electrical Characteristics of Bell System Network Facilities at the Interface with Voice-band Ancillary and Data Equipment,” August 1976.

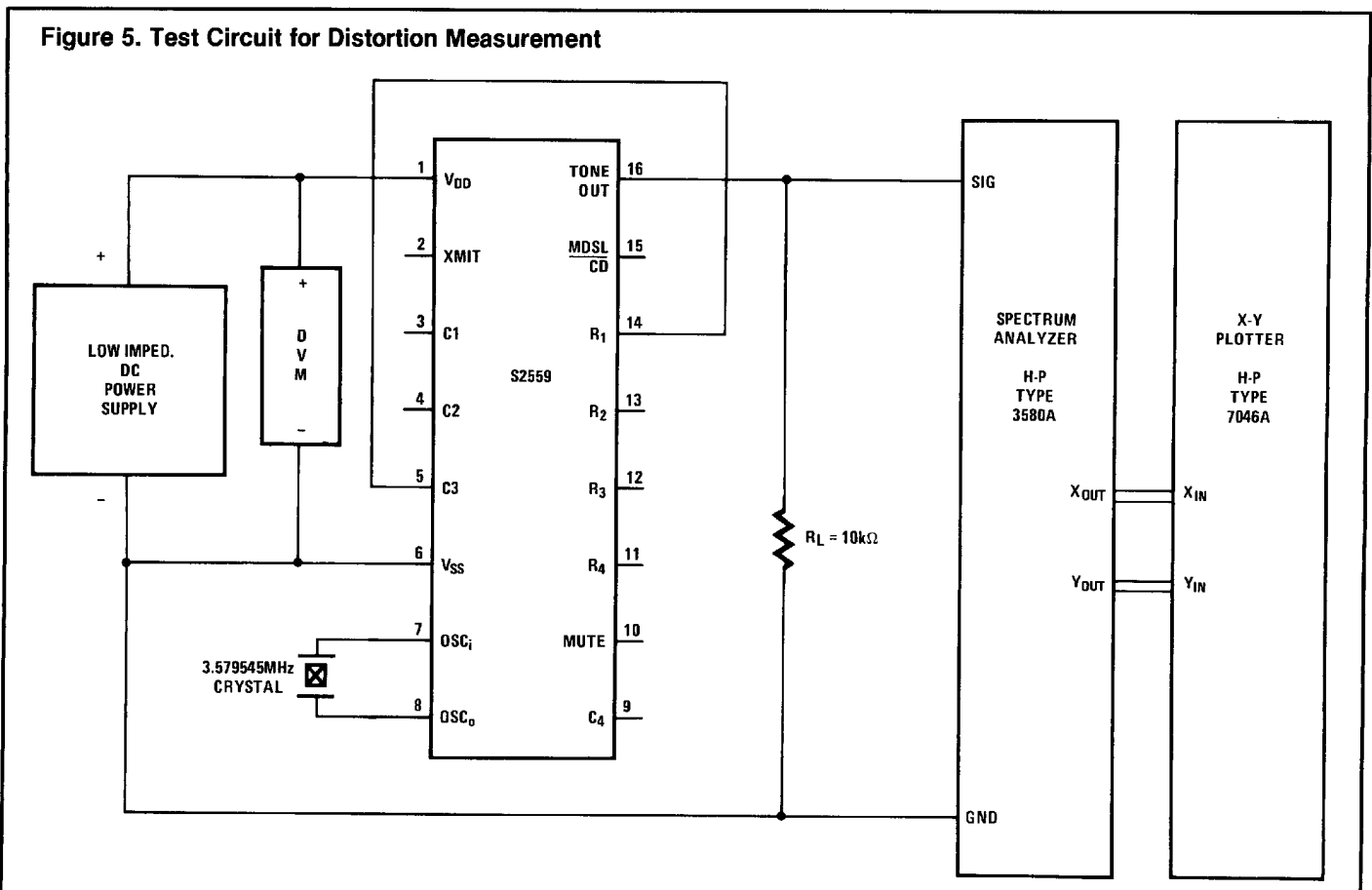

August 1996

DTMF Tone Generator

Figure 6. A Typical Spectrum Plot

