

2MBI50F-060 (50A)

IGBT Module

600V / 50A 2 in one-package

■ 特長 : Features

低飽和電圧 Low Saturation Voltage
 高入力ゲート抵抗 (MOS構造) High Input Impedance
 豊富な容量系列 Variety of Power Capacity Series

■ 用途 : Applications

汎用インバータ General Purpose Inverter
 AC, DCサーボアンプ AC and DC Servo drive amplifier
 無停電電源装置 Uninterruptible power supply
 溶接機等の産業用機器
 Industrial Machines, such as Welding Machine

■ 定格と特性 : Maximum ratings and characteristics

● 絶対最大定格 : Absolute maximum ratings

Item	Symbol	Rating	Unit
コレクタ・エミッタ間電圧	V _{CES}	600	V
ゲート・エミッタ間電圧	V _{GES}	±20	V
コレクタ電流	連続	I _C	50
	1ms	I _C pulse	100
	連続	-I _C	50
	1ms	-I _C pulse	100
最大損失	P _c	220	W
接合部温度	T _j	+150	°C
保存温度	T _{stg}	-40 to +125	°C
質量		185	g
絶縁耐量	V _{is}	AC 2500 (1min.)	V
締付けトルク	Mounting *1	3.5	N·m
	Terminals *1	3.5	N·m

*1推奨値 : Recommendable value : 2.5 to 3.5 N·m [25 to 35kgf·cm] (M5)

■ 外形寸法 Outline Drawings

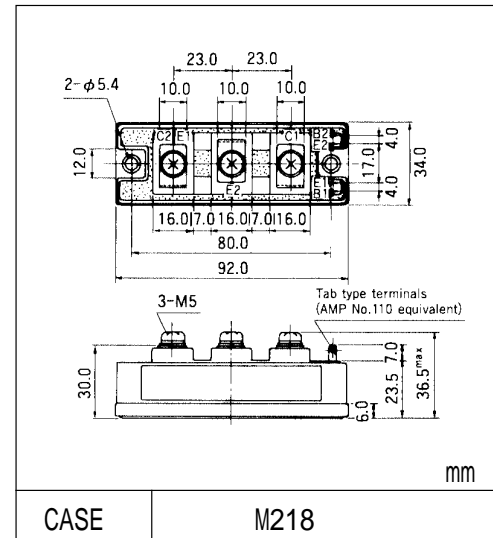

■ 等価回路

Equivalent Circuit Schematic

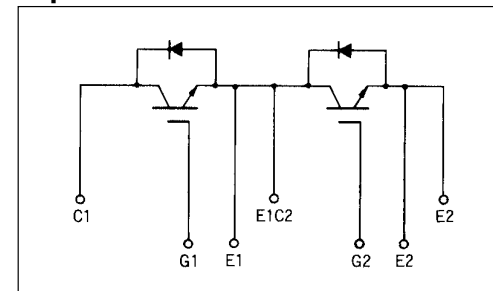

● 電気的特性 : Electrical characteristics (T_j=25°C)

Item	Symbol	Test Conditions	Characteristics			Unit	
			Min.	Typ.	Max.		
コレクタ・エミッタ間遮断電流	I _{CES}	V _{GE} =0V, V _{CE} =600V, T _j =25°C	-	-	1.0	mA	
ゲート・エミッタ間漏れ電流	I _{GES}	V _{CE} =0V, V _{GE} =±20V	-	-	100	nA	
ゲート・エミッタ間しきい値電圧	V _{GE(th)}	V _{CE} =20V, I _C =50mA	3.0	-	6.0	V	
コレクタ・エミッタ間飽和電圧	V _{CE(sat)}	V _{GE} =15V, I _C =50A	-	-	2.5	V	
入力容量	C _{ies}	V _{GE} =0V	-	4750	-	pF	
出力容量	C _{oes}	V _{CE} =10V	-	-	-		
帰還容量	C _{res}	f=1MHz	-	-	-		
ターンオン時間	t _{on}	V _{CC} =300V	Resistive load	-	-	0.8	μs
	t _r	I _C =50A		-	-	0.6	
ターンオフ時間	t _{off}	V _{GE} =±15V	Inductive load	-	-	1.5	
	t _f	R _G =51 ohm		-	-	1.0	
ダイオード順電圧	V _F	I _F =50A, V _{GE} =0V	-	-	2.5	V	
逆回復時間	t _{rr}	I _F =50A, -di/dt=150A/μs, V _{GE} =-10V	-	-	300	ns	

● 熱的特性 : Thermal resistance characteristics

Items	Symbol	Test Conditions	Characteristics			Unit
			Min.	Typ.	Max.	
熱抵抗	R _{th(j-c)}	IGBT	-	-	0.568	°C/W
	R _{th(j-e)}	Diode	-	-	1.33	°C/W
	R _{th(c-f)}	With Thermal compound	-	0.05	-	°C/W

■ Characteristics

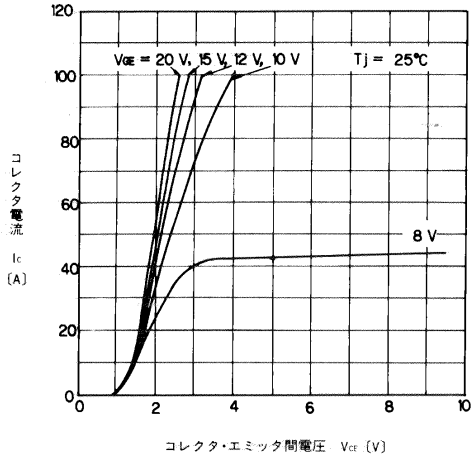

コレクタ電流—コレクタ・エミッタ間電圧特性
Collector Current vs. Collector-Emitter Voltage

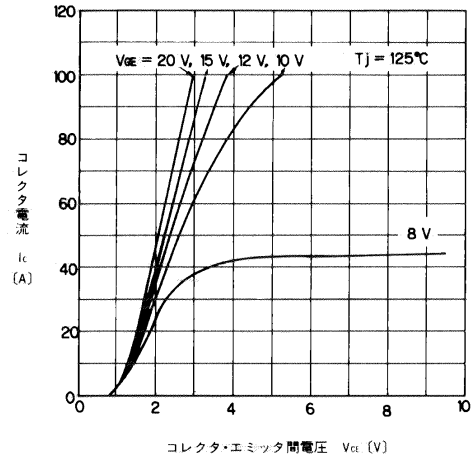

コレクタ電流—コレクタ・エミッタ間電圧特性
Collector Current vs. Collector-Emitter Voltage

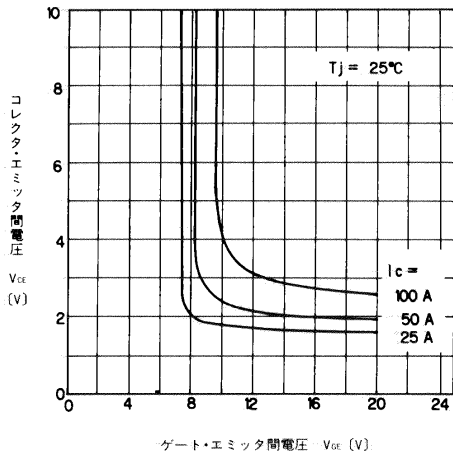

コレクタ・エミッタ間電圧—ゲート・エミッタ間電圧特性
Collector-Emitter Voltage vs. Gate-Emitter Voltage

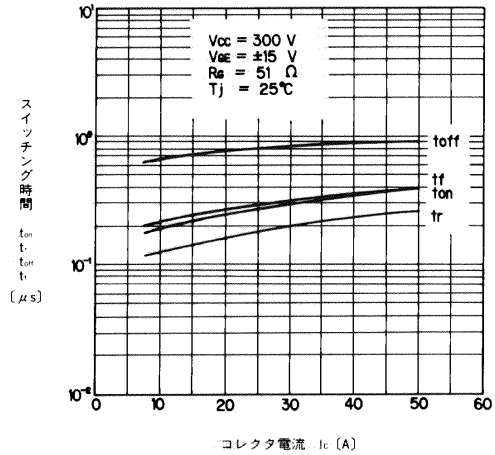

スイッチング時間—コレクタ電流特性
Switching Time vs. Collector Current

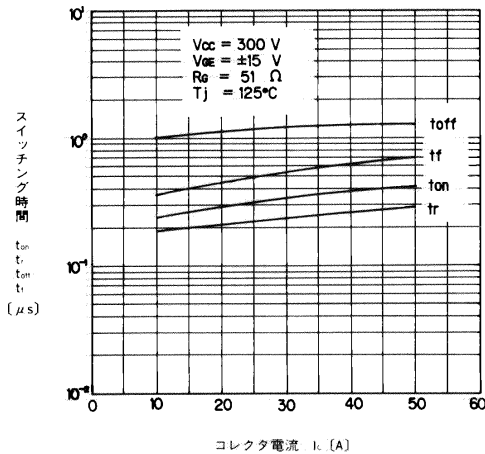

スイッチング時間—コレクタ電流特性
Switching Time vs. Collector Current

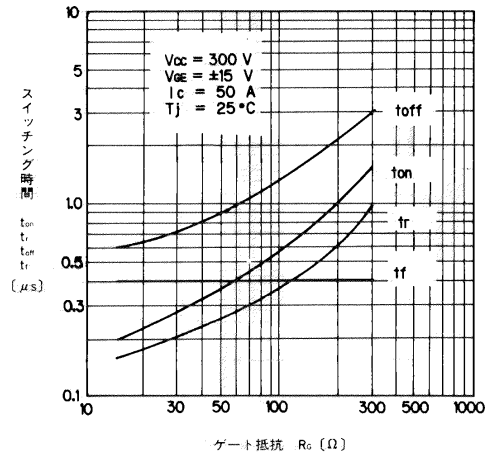

スイッチング時間—ゲート抵抗特性
Switching Time vs. Gate Resistance

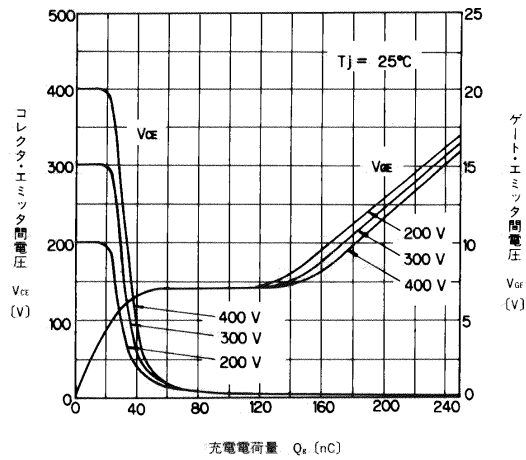

ダイナミック入力特性
Dynamic Input Characteristic

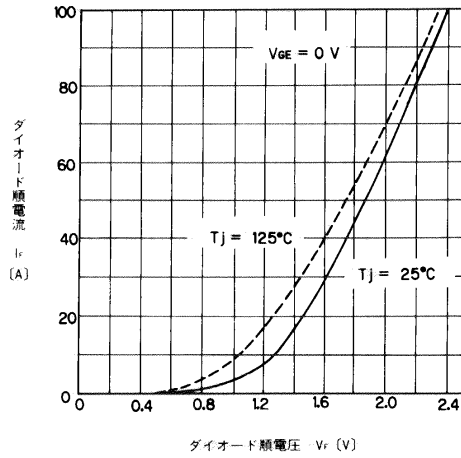

高速フリーホイールダイオード順電圧特性
Forward Voltage of Free Wheel Diode

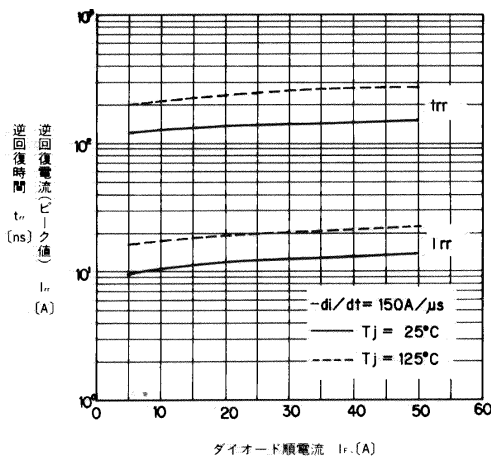

trr, Irr-If特性
Trr, Irr-If

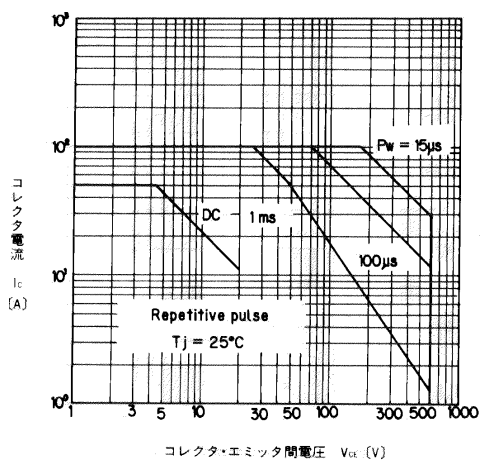

安全動作領域(繰り返し)
Safe Operating Area

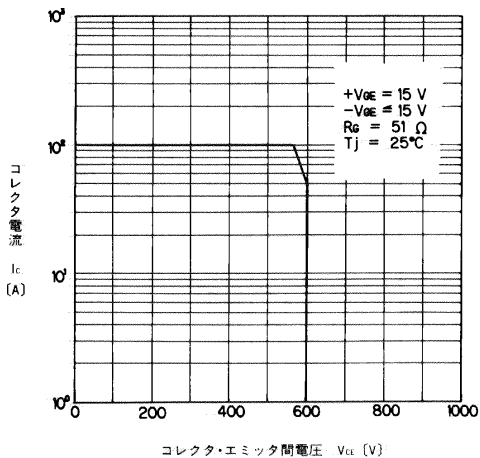

安全動作領域(逆バイアス)
Reverse Biased Safe Operating Area

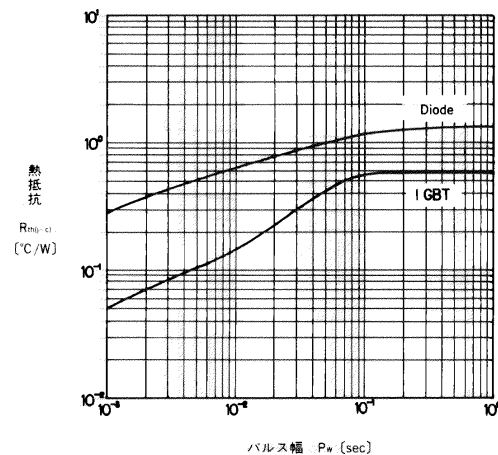

過渡熱抵抗
Transient Thermal Resistance