



Tuffy II® Liquid Level Controls with Electric Switches

DESCRIPTION

The Tuffy® II Liquid Level Switches are float-actuated devices designed for horizontal mounting in a tank or vessel through threaded or flanged pipe connections. The compact size allows for installation in small vessels, while its many features provide a variety of application uses. The single switch mechanism is available in SPDT or DPDT forms on units designed for fixed or adjustable, narrow or wide differential and interface service levels. This sales literature covers Tuffy II level switches that have electric switches. For Tuffy with a pneumatic switch, see bulletin 44-109.

TECHNOLOGY

The Tuffy II achieves switching action through the use of a magnetic switch mechanism and a magnet attached to the float assembly. Separating the two magnets is a non-magnetic pressure barrier.

As the liquid level changes, the float, and therefore the float magnet, moves. The float and switch magnets repel each other causing movement of the switch magnet assembly, tripping the switch and making or breaking an electrical circuit.

FEATURES

- Pressure ratings to 2625 psi (181 bar)
- Process temperatures to +750° F (+399° C)
- Cost-effective clad flange design option
- NACE and/or ASME B31.3 construction
- Specific gravity as low as 0.40



APPLICATIONS

- Sour service (NACE)
- High/low alarm
- Single pump control
- Day storage tanks
- Corrosive processes (Hastelloy® C wetted parts)
- Process vessels
- Boiler low water cut-off
- Interface level
- Explosion proof installations

ADDITIONAL FEATURES

- Carbon steel with 316 SS, all 316 SS or all Hastelloy C wetted components
- Enlarged switch enclosure for wiring ease
- Explosion proof NEMA 4X/7/9 enclosure
- All models available with FM, CSA and ATEX approvals
- Choice of cast aluminum or cast iron switch enclosure
- Interface service with 0.10 minimum specific gravity difference
- External cages available in carbon steel and 316 stainless steel
- Fixed narrow differential models
- Adjustable wide differential models
- Wide selection of process connections:
 - 2" NPT
 - 3" to 6" ANSI flanges
 - ANSI flanges pressure classes from 150# to 900#
- Wide selection of switches:
 - SPDT or DPDT
 - Silver or gold contacts
 - Dry contact
 - Hermetically sealed

PHYSICAL SPECIFICATIONS

Measured Variable:	Liquid level	
Deadband:	Narrow differential = 0.50"	
	Wide differential = up to 18.26"	
	Interface service differential 1.72"	
Float & Trim Parts:	316 stainless steel or Hastelloy C	
Flange Materials:	Carbon steel, 316 stainless steel, 316 stainless steel clad carbon steel Hastelloy C, or Hastelloy C clad carbon steel	
Process Connections:	2" NPT, 3" to 6" ANSI flanges in 150# to 900# pressure classes	
Process Temp Range*:	Cast Iron Housing	Cast Aluminum Housing
HS with silver contacts	-65° to +750° F (-54° to +399° C)	-65° to +650° F (-54° to +343° C)
HS with gold contacts	-65° to +750° F (-54° to +399° C)	-65° to +650° F (-54° to +343° C)
Snap with silver contacts	-40° to +750° F (-40° to +399° C)	-40° to +650° F (-40° to +343° C)
Snap with gold contacts	-40° to +375° F (-40° to +190° C)	-40° to +325° F (-40° to +162° C)
Ambient Temp. Range*	0° to +100° F (-18° to +38° C)	
Maximum Process Pressure:	2630 psig (181 bar)	

* For ambient temperatures outside of the listed range, consult factory or bulletin 44-607 for maximum allowable process temperature.

ELECTRICAL SPECIFICATIONS

Signal Output:	Switch closure
Type of Contacts:	SPDT or DPDT
Contact Material:	Silver or gold
Type of Switches:	Dry contact or Hermetically sealed
Switch Ratings:	Up to 10 amps @ 120/240 VAC Up to 6 amps @ 24 VDC
Enclosure Rating:	NEMA 4X/7/9, Class I, Div 1, Groups B, C & D, IP66
Enclosure Material:	Cast aluminum or cast iron
Cable Entry:	¾" NPT

DIMENSIONAL SPECIFICATIONS

INCHES (MM)

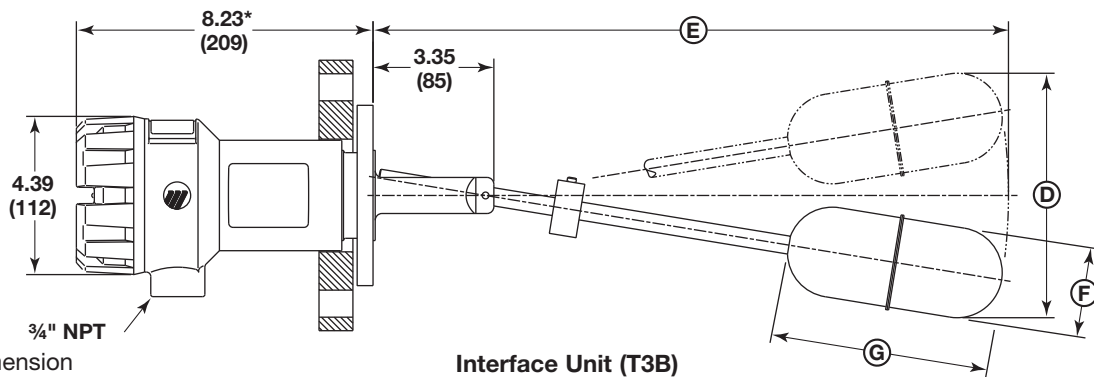
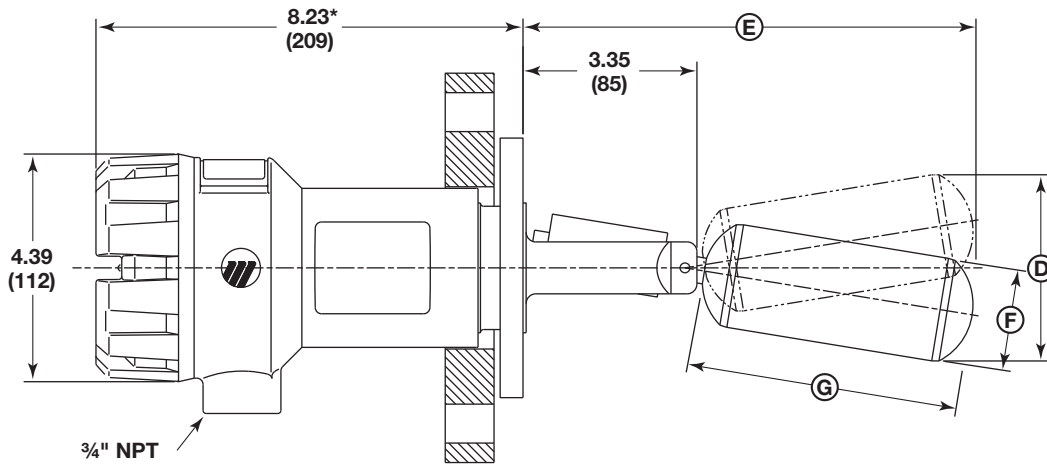
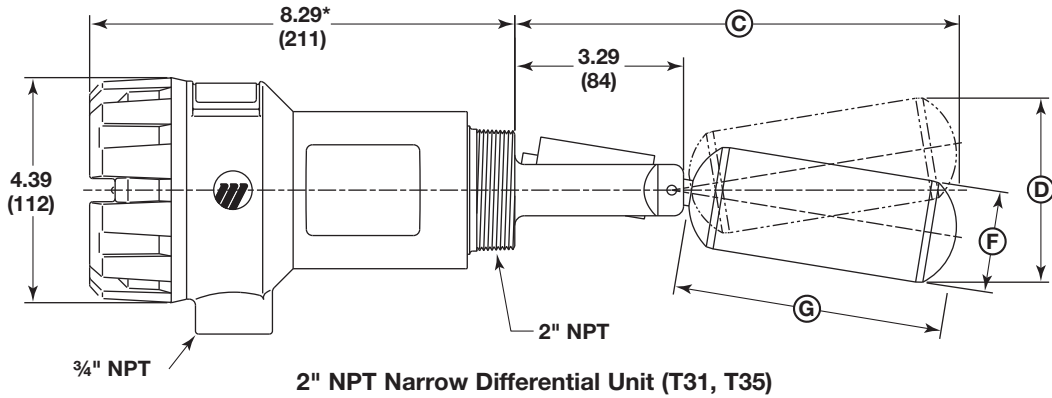

* This dimension applies to cast iron housing. Subtract 0.31" for aluminum housing.

Inches (mm)

Dimension	T31	T32	T33	T34	T35	T3B	T3C		
B	—	—	—	—	—	—	3.75 (95)	7.5 (190)	12.25 (311)
C	8.66 (220)	—	—	—	7.86 (199)	—	—	—	—
D	3.59 (91)	3.36 (85)	3.58 (91)	3.59 (91)	3.33 (85)	6.78 (172)	13.62 (346)	18.54 (471)	24.76 (629)
E	8.72 (221)	8.02 (204)	7.50 (190)	7.97 (202)	7.92 (201)	17.62 (448)	12.86 (327)	16.61 (422)	21.36 (543)
F	2.00 (51)	2.00 (51)	2.38 (60)	2.00 (51)	2.00 (51)	2.66 (68)	2.66 (68)		
G	5.25 (133)	4.55 (116)	4.00 (102)	4.50 (114)	4.45 (113)	6.00 (152)	6.00 (152)		
Maximum Nozzle Length	3.29 (84)	3.35 (85)	3.35 (85)	3.35 (85)	3.29 (84)	5.80 (147)	4.35 (110)		

DIMENSIONAL SPECIFICATIONS

INCHES (MM)

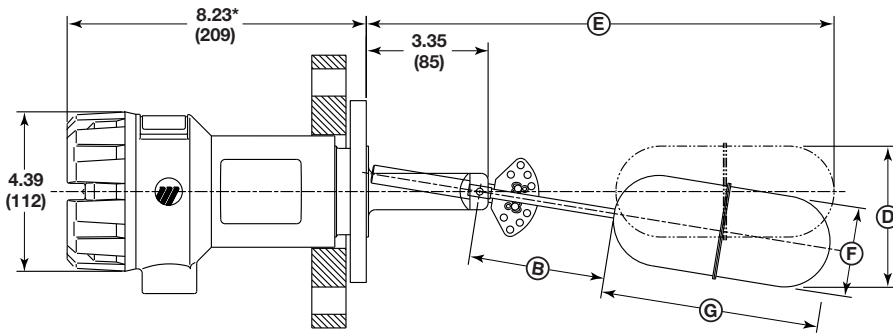

Adjustable Differential Unit (T3C)

* This dimension applies to cast iron housing.
Subtract 0.31" for aluminum housing.

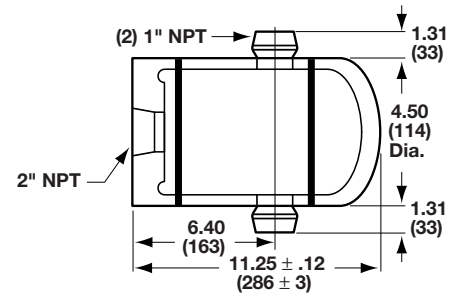

Tuffy Chamber

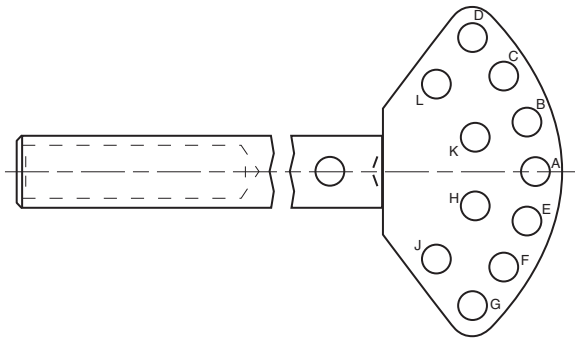

Adjustment Plate Stop Position





Tuffy II Maximum Nozzle Lengths (distance from face of mounting flange to end of 3" sch 80 nozzle or the tip of the mounting threads to the end of 2" nozzle with ID same as 2" NPT)	
T31 or T35 with NPT connection	3.29"
T31, T32, T33, T34 or T35 with flanged connection	3.35"
T3B	5.80"
T3C	4.35"

Figure 1
Maximum nozzle length

	Stem Length	Pin Position											
		A	B	C	D	E	F	G	H	J	K	L	
Rising	3.75	+0.16	+1.84	+3.54	+4.87	-1.47	n/a	n/a	-1.65	n/a	+1.52	+4.10	
	7.50	-0.12	+2.49	+5.14	+7.20	-2.65	n/a	n/a	-2.94	n/a	+1.99	+6.01	
	12.25	-0.43	+3.36	+7.20	+10.20	-4.12	n/a	n/a	-4.54	n/a	+2.62	+8.46	
Falling	3.75	+1.51	+3.14	n/a	n/a	-0.39	-1.87	-3.21	0.16	-2.44	+3.32	n/a	
	7.50	+1.98	+4.51	n/a	n/a	-0.99	-3.29	-5.37	-0.12	-4.16	+4.80	n/a	
	12.25	+2.61	+6.28	n/a	n/a	-1.69	-5.04	-8.06	-0.44	-6.31	+6.71	n/a	

Stop Position Actuation Levels
(Inches (± 0.25) at minimum S.G.)

AGENCY APPROVALS

AGENCY	APPROVED MODEL	PROTECTION METHOD	AREA CLASSIFICATION
FM 	T3X-XXXX-XXA T3X-XXXX-XXB	Explosion Proof	Class I, Div 1; Groups B, C, D Class II, Div 1; Groups E, F, G Class III, NEMA 4X IP66
CSA 	T3X-XXXX-XXC T3X-XXXX-XXD	Explosion Proof	Class I, Div1; Groups B, C, D Class II, Div 1; Groups E, F, G Class III, Div 1; Type 4X
ATEX 	T3X-XXXX-XX1 T3X-XXXX-XX2 T3X-XXXX-XX3 T3X-XXXX-XX4	Flame Proof ①	ATEX II ½ G EEx d II C T6 94/9/EC IP66
	T3X-XXXX-XXM T3X-XXXX-XXN T3X-XXXX-XXP T3X-XXXX-XXR	Intrinsically Safe ②	ATEX II 1G EEx ia II C T6 IP66
CE 	T3X-XXXX-XXX	Low Voltage Directives 2006/95/EC Per Horizontal Standard: EN 61010-1/1993 & Amendment No. 1	Installation Category II Pollution Degree 2

Special conditions for safe use:

- ① When the equipment is installed, particular precautions must be take to ensure, taking into account the effect of the process temperature, that the ambient temperature of the electrical parts is between -40° and +70° C.
- ② When the material is equipped with a aluminum enclosure, all precautions shall be taken to avoid all impacts or frictions which can result in the ignition of the potentially explosive atmosphere.

MODEL NUMBERS

- Narrow Differential:** Switch differential of approximately 0.5" (1.7" on interface unit), for actuation of an alarm or system shutdown.
- Interface Service:** Switch to detect the interface between two liquids with SGUs that differ by at least 0.1.
- Single Liquid:** Switch to detect the top of layer of a single liquid with no other liquid above it.
- Adjustable Differential:** Wide switch differential from approximately 1.36" to 18.26", which may be adjusted in the field by repositioning pins on the adjustment plate.

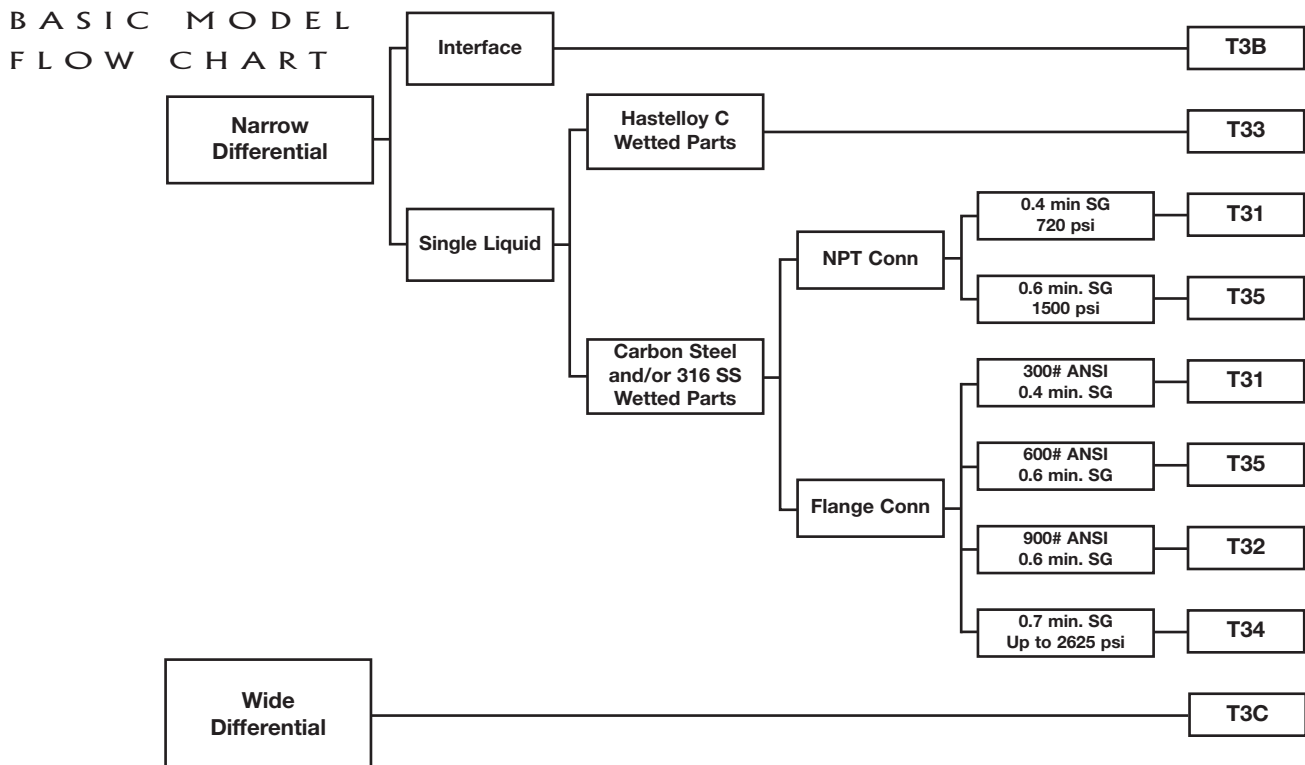

STANDARD NARROW DIFFERENTIAL

MODEL NUMBER



Models available for quick shipment, usually within one week after factory receipt of a complete purchase order, through the Expedite Ship Plan (ESP).

BASIC MODEL NUMBER

T 3	Tuffy II Electric Liquid Level Switch
-----	---------------------------------------

FUNCTION/FLOAT

Code	Level Differential	SGU Min	① Max. Pressure psig (bar)	Compatible Model Codes		
				Process Connection Size Codes	Process Connection Type Codes	Process Connection Material/Design Codes
1	Narrow (0.5")	0.40	750 (52)	All	N, A, B	A,B,E,F,J,K,N,P,1,2
2		0.60	2220 (153)	3, 4, 5, 6	A, B, C, D	A,B,E,F,J,K,N,P,1,2
3		0.65	750 (52)	3, 4, 5, 6	A, B	C,D,G,H,L,M,R,T
4		0.70	2630 (181)	4	E	A,B,E,F,J,K,N,P,1,2
5		0.60	1500 (103)	All	N, A, B, C	A,B,E,F,J,K,N,P,1,2

PROCESS CONNECTION SIZE

Code	Size	Compatible Model Codes		
		Function/Float Codes	Process Connection Type Codes	Process Connection Material/Design Codes
2	2"	1, 5	N	B, F, K, P
3	ANSI 3"	1, 2, 3, 5	A, B, C, D	All
4	ANSI 4"	1, 2, 3, 4, 5	A, B, C, D, E	All
5	ANSI 5"	1, 2, 3, 5	A, B	All
6	ANSI 6"	1, 2, 3, 5	A, B	All

PROCESS CONNECTION TYPE ①

Code	Type	Compatible Model Codes		
		Function/Float Codes	Process Connection Size Codes	Process Connection Material/Design Codes
N	NPT	1, 5	2	B, F, K, P
A	ANSI RF Flange, 150#	1, 2, 3, 5	3, 4, 5, 6	All
B	ANSI RF Flange, 300#	1, 2, 3, 5	3, 4, 5, 6	All
C	ANSI RF Flange, 600#	2, 5	3, 4	A, B, E, F, J, K, N, P, 1, 2
D	ANSI RF Flange, 900#	2	3, 4	A, B, E, F, J, K, N, P, 1, 2
E	ANSI RF Flange, 1500#	4	4	A, B, E, F, J, K, N, P, 1, 2

PROCESS CONNECTION MATERIAL/DESIGN CODE

SWITCH TYPE
HOUSING MATERIAL/APPROVAL
See opposite page

① Rated pressure limited by maximum Float or Flange pressure, whichever is less.

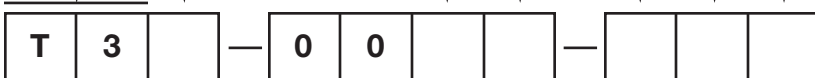

STANDARD NARROW DIFFERENTIAL cont.

MODEL NUMBER

PROCESS CONNECTION MATERIAL/DESIGN CODE

Standard	ASME B31.3	NACE	ASME B31.3 & NACE	Process Connection Material	Compatible Model Codes		
					Function/Float Codes	Process Connection Size Codes	Process Connection Type Codes
1	2	Not applicable	Not applicable	Carbon Steel Flange and cladding with 316/316L SS float holder & trim	1, 2, 4, 5	3, 4, 5, 6	A, B, C, D, E
A	E	J	N	Carbon Steel Flange with 316/316L SS process wetted face	1, 2, 4, 5	3, 4, 5, 6	A, B, C, D, E
B	F	K	P	All 316/316L Stainless Steel	1, 2, 4, 5	All	All
C	G	L	R	Carbon Steel Flange with Hastelloy C process wetted face	3	3, 4, 5, 6	A, B
D	H	M	T	All Hastelloy C	3	3, 4, 5, 6	A, B

SWITCH TYPE

Code	Contact Type and Material	Electric Switch Rating				Maximum Process Temperature ①②	
		VAC		VDC		Cast Iron Housing	Cast Alum Housing
		120	240	24	120		
0	SPDT w/silver contacts	10.0	10.0	6.0	0.6	+750°F (+399°C)	+650°F (+343°C)
1	DPDT (dual SPDT) w/silver contacts	10.0	10.0	6.0	0.6	+750°F (+399°C)	+650°F (+343°C)
2	SPDT w/gold plated contacts	0.1	—	0.1	—	+375°F (+190°C)	+325°F (+162°C)
3	DPDT (dual SPDT) w/gold plated contacts	0.1	—	0.1	—	+375°F (+190°C)	+325°F (+162°C)
4	HS SPDT w/silver contacts	1.0	1.0	3.0	0.5	+750°F (+399°C)	+650°F (+343°C)
6	HS SPDT w/gold plated contacts	0.5	0.5	0.5	0.5	+750°F (+399°C)	+650°F (+343°C)

① Maximum process temperature is based on an ambient temperature between 0° and +100° F. If ambient is outside this range, consult factory.

② See Switch temperature ranges on page 2 for minimum process temperatures

HOUSING MATERIAL/APPROVAL

FM	CSA	ATEX EP	ATEX IS	
A	C	1	M	Cast Aluminum, 3/4" NPT Conduit Entry
B	D	2	N	Cast Iron, 3/4" NPT Conduit Entry
N/A		3	P	Cast Aluminum, M20 X 1.5 Conduit Entry
		4	R	Cast Iron, M20 X 1.5 Conduit Entry

--	--	--

CHAMBER

PART NUMBER

MATERIALS OF CONSTRUCTION/PRESSURE RATING

0-001	Carbon Steel	2200 psig @ +400° F (152 bar @ +204° C), 1400 psig @ +750° F (97 bar @ +399° C)
0-002	316 Stainless Steel	2500 psig @ +400° F (172 bar @ +204° C), 2013 psig @ +750° F (139 bar @ +399° C)
1-001	Carbon Steel	1200 psig @ +400° F (83 bar @ +204° C), 780 psig @ +750° F (54 bar @ +399° C)
1-002	316 Stainless Steel	1400 psig @ +400° F (97 bar @ +204° C), 1127 psig @ +750° F (78 bar @ +399° C)

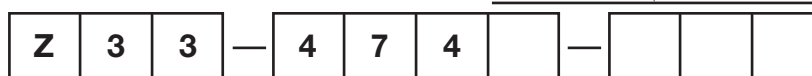

Note: Flanged chambers and process flanges available. Consult factory.

INTERFACE

MODEL NUMBER

Process Connection: ANSI Flanges
Wetted Materials: Carbon Steel and/or 316/316L SS
Max. Float Pressure: 750 psi (52 bar) ①
Min. SG of Lower Liquid: 0.81
Min SG difference: 0.1
Level Differential: 1.72"

BASIC MODEL NUMBER

T 3	Tuffy II Electric Liquid Level Switch
-----	---------------------------------------

FUNCTION/FLOAT

B	Interface Level
---	-----------------

LOWER FLUID SPECIFIC GRAVITY

0.81	0.82	0.83	0.84	0.85	0.86	0.87	0.88	0.89	0.90	Specific Gravity
A	B	C	D	E	F	G	H	J	K	Code
0.91	0.92	0.93	0.94	0.95	0.96	0.97	0.98	0.99	1.00	Specific Gravity
L	M	N	P	R	S	T	U	V	W	Code

PROCESS CONNECTION SIZE

3	ANSI 3"
4	ANSI 4"
5	ANSI 5"
6	ANSI 6"

PROCESS CONNECTION TYPE ①

A	ANSI RF Flange, 150#
B	ANSI RF Flange, 300#

① Rated pressure limited by maximum Float or Flange pressure, whichever is less.

PROCESS CONNECTION MATERIAL/DESIGN CODE

SWITCH TYPE

HOUSING MATERIAL/APPROVAL

See opposite page

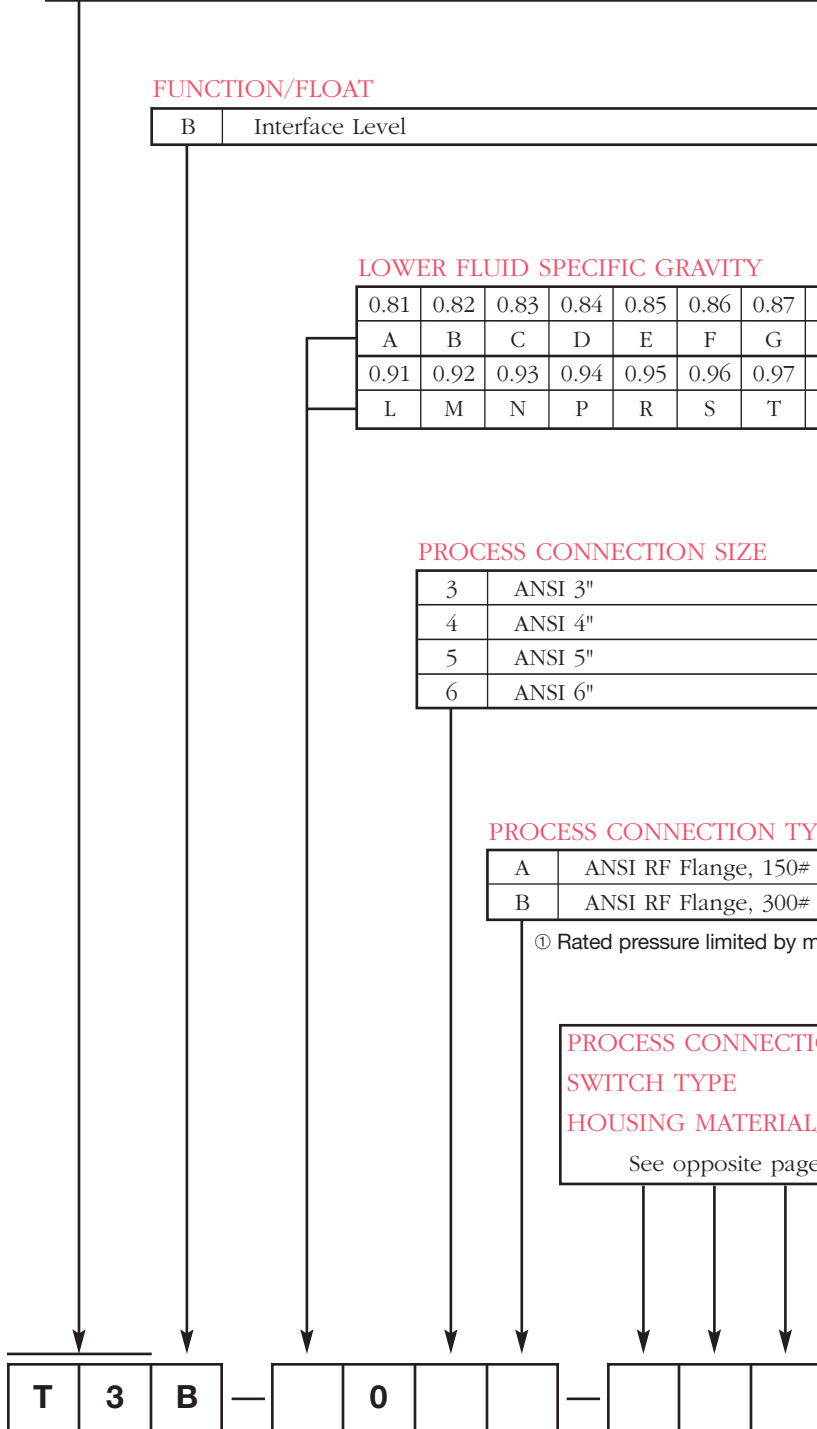

INTERFACE continued

MODEL NUMBER

PROCESS CONNECTION MATERIAL/DESIGN CODE

Standard	ASME B31.3	NACE	ASME B31.3 & NACE	Process Connection Material
1	2	Not applicable	Not applicable	Carbon Steel Flange and cladding with 316/316L SS float holder & trim
A	E	J	N	Carbon Steel Flange with 316/316L SS process wetted face
B	F	K	P	All 316/316L Stainless Steel

SWITCH TYPE

Code	Contact Type & Material	Electric Switch Rating				Maximum Process Temperature ①②	
		VAC		VDC		Cast Iron Housing	Cast Alum Housing
		120	240	24	120		
0	SPDT w/silver contacts	10.0	10.0	6.0	0.6	+750°F (+399°C)	+650°F (+343°C)
1	DPDT (dual SPDT) w/silver contacts	10.0	10.0	6.0	0.6	+750°F (+399°C)	+650°F (+343°C)
2	SPDT w/gold plated contacts	0.1	—	0.1	—	+375°F (+190°C)	+325°F (+162°C)
3	DPDT (dual SPDT) w/gold plated contacts	0.1	—	0.1	—	+375°F (+190°C)	+325°F (+162°C)
4	HS SPDT w/silver contacts	1.0	1.0	3.0	0.5	+750°F (+399°C)	+650°F (+343°C)
6	HS SPDT w/gold plated contacts	0.5	0.5	0.5	0.5	+750°F (+399°C)	+650°F (+343°C)

- ① Maximum process temperature is based on an ambient temperature between 0° and +100° F. If ambient is outside this range, consult factory.
 ② See Switch temperature ranges on page 2 for minimum process temperatures

HOUSING MATERIAL/APPROVAL

FM	CSA	ATEX EP	ATEX IS	
A	C	1	M	Cast Aluminum, ¾" NPT Conduit Entry
B	D	2	N	Cast Iron, ¾" NPT Conduit Entry
N/A		3	P	Cast Aluminum, M20 X 1.5 Conduit Entry
		4	R	Cast Iron, M20 X 1.5 Conduit Entry

--	--	--

ADJUSTABLE WIDE DIFFERENTIAL

MODEL NUMBER

Process Connection: ANSI Flanges
Wetted Materials: Carbon steel and/or 316/316L SS
Max. Float Pressure: 750 psi (52 bar) ①
Min SG: 0.78
Level Differential: Adjustable from 1.36" to 18.26"

BASIC MODEL NUMBER

T 3	Tuffy II Electric Liquid Level Switch
-----	---------------------------------------

FUNCTION/FLOAT

C	Adjustable Differential Level
---	-------------------------------

STEM EXTENSION LENGTH "B" DIMENSION

4	3.75 inch (95 mm) stem extension
8	7.50 inch (190 mm) stem extension
C	12.25 inch (311 mm) stem extension

PROCESS CONNECTION SIZE

3	ANSI 3"
4	ANSI 4"
5	ANSI 5"
6	ANSI 6"

PROCESS CONNECTION TYPE ①

A	ANSI RF Flange, 150#
B	ANSI RF Flange, 300#

① Rated pressure limited by maximum Float or Flange pressure, whichever is less.

PROCESS CONNECTION MATERIAL/DESIGN CODE

SWITCH TYPE

HOUSING MATERIAL/APPROVAL

See opposite page

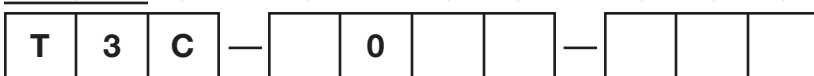

ADJUSTABLE WIDE DIFFERENTIAL continued

MODEL NUMBER

PROCESS CONNECTION MATERIAL/DESIGN CODE

Standard	ASME B31.3	NACE	ASME B31.3 & NACE	Process Connection Material
1	2	Not applicable	Not applicable	Carbon Steel Flange and cladding with 316/316L SS float holder & trim
A	E	J	N	Carbon Steel Flange with 316/316L SS process wetted face
B	F	K	P	All 316/316L Stainless Steel

SWITCH TYPE

Code	Contact Type and Material	Electric Switch Rating				Maximum Process Temperature ①②	
		VAC		VDC		Cast Iron Housing	Cast Alum Housing
		120	240	24	120		
0	SPDT w/silver contacts	10.0	10.0	6.0	0.6	+750°F (+399°C)	+650°F (+343°C)
1	DPDT (dual SPDT) w/silver contacts	10.0	10.0	6.0	0.6	+750°F (+399°C)	+650°F (+343°C)
2	SPDT w/gold plated contacts	0.1	—	0.1	—	+375°F (+190°C)	+325°F (+162°C)
3	DPDT (dual SPDT) w/gold plated contacts	0.1	—	0.1	—	+375°F (+190°C)	+325°F (+162°C)
4	HS SPDT w/silver contacts	1.0	1.0	3.0	0.5	+750°F (+399°C)	+650°F (+343°C)
6	HS SPDT w/gold plated contacts	0.5	0.5	0.5	0.5	+750°F (+399°C)	+650°F (+343°C)

- ① Maximum process temperature is based on an ambient temperature between 0° F and +100° F. If ambient is outside this range, consult factory.
- ② See Switch temperature ranges on page 2 for minimum process temperatures

HOUSING MATERIAL/APPROVAL

FM	CSA	ATEX EP	ATEX IS	
A	C	1	M	Cast Aluminum, 3/4" NPT Conduit Entry
B	D	2	N	Cast Iron, 3/4" NPT Conduit Entry
N/A		3	P	Cast Aluminum, M20 X 1.5 Conduit Entry
		4	R	Cast Iron, M20 X 1.5 Conduit Entry

STOP POSITION ACTUATION LEVELS (INCHES ± 0.25 AT MINIMUM S.G.)

	Stem Length	Pin Position										
		A	B	C	D	E	F	G	H	J	K	L
Rising	3.75	+0.16	+1.84	+3.54	+4.87	-1.47	n/a	n/a	-1.65	n/a	+1.52	+4.10
	7.50	-0.12	+2.49	+5.14	+7.20	-2.65	n/a	n/a	-2.94	n/a	+1.99	+6.01
	12.25	-0.43	+3.36	+7.20	+10.20	-4.12	n/a	n/a	-4.54	n/a	+2.62	+8.46
Falling	3.75	+1.51	+3.14	n/a	n/a	-0.39	-1.87	-3.21	0.16	-2.44	+3.32	n/a
	7.50	+1.98	+4.51	n/a	n/a	-0.99	-3.29	-5.37	-0.12	-4.16	+4.80	n/a
	12.25	+2.61	+6.28	n/a	n/a	-1.69	-5.04	-8.06	-0.44	-6.31	+6.71	n/a

QUALITY



The quality assurance system in place at Magnetrol guarantees the highest level of quality throughout the company. Magnetrol is committed to providing full customer satisfaction both in quality products and quality service.

Magnetrol's quality assurance system is registered to ISO 9001 affirming its commitment to known international quality standards providing the strongest assurance of product/service quality available.

ESP

Expedite Ship Plan

Several Tuffy II Float Level Switches are available for quick shipment, usually within one week after factory receipt of a purchase order, through the Expedite Ship Plan (ESP).

To take advantage of ESP, match the color coded model number codes in the selection charts (standard dimensions apply).

ESP service may not apply to orders of ten units or more. Contact your local representative for lead times on larger volume orders, as well as other products and options.

WARRANTY



All Magnetrol mechanical level and flow controls are warranted free of defects in materials or workmanship for five full years from the date of original factory shipment.

If returned within the warranty period; and, upon factory inspection of the control, the cause of the claim is determined to be covered under the warranty; then, Magnetrol will repair

or replace the control at no cost to the purchaser (or owner) other than transportation.

Magnetrol shall not be liable for misapplication, labor claims, direct or consequential damage or expense arising from the installation or use of equipment. There are no other warranties expressed or implied, except special written warranties covering some Magnetrol products.



5300 Belmont Road • Downers Grove, Illinois 60515-4499 • 630-969-4000 • Fax 630-969-9489 • www.magnetrol.com
145 Jardin Drive, Units 1 & 2 • Concord, Ontario Canada L4K 1X7 • 905-738-9600 • Fax 905-738-1306
Heikensstraat 6 • B 9240 Zele, Belgium • 052 45.11.11 • Fax 052 45.09.93
Regent Business Ctr., Jubilee Rd. • Burgess Hill, Sussex RH15 9TL U.K. • 01444-871313 • Fax 01444-871317

Copyright © 2010 Magnetrol International, Incorporated. All rights reserved. Printed in the USA.

Performance specifications are effective with date of issue and are subject to change without notice.

Magnetrol and Magnetrol logotype are registered trademarks of Magnetrol International.
Hastelloy® is a registered trademark of Haynes International, Inc.

CSA logotype is a registered trademark of Canadian Standards Association

BULLETIN: 44-106.9
EFFECTIVE: May 2010
SUPERSEDES: March 2007