

DD312

Version : A.001
Issue Date : 2007/07/18
File Name : SP-DD312-A.001.doc
Total Pages: 20

HIGH CONSTANT CURRENT LED DRIVER
with ERROR DETECTION



新竹市科學園區展業一路9號7樓之1
SILICON TOUCH TECHNOLOGY INC.
9-7F-1, Prosperity Road I, Science Based Industrial Park,
Hsin-Chu, Taiwan 300, R.O.C.
Tel : 886-3-5645656 Fax : 886-3-5645626



DD312

HIGH CONSTANT CURRENT LED DRIVER with ERROR DETECTION

General Description

DD312 is a high constant current driver designed for LED lighting application and power LEDs. It incorporates a constant current circuitry with current value set by an external resistor. The output enable terminal allows dimming control by system. The fast response of output current can adapt to high dimming resolution and high refresh rate applications. Built-in LED open detection, over temperature, and over current protection functions ensure the system reliability.

Features

- Maximum output current: 1A (determined by the external resistor)
- Minimum output voltage: 1V ($I_{out} = 1A$)
- Maximum output voltage: 18V
- Output enable terminal: 1MHz (max.)
- Supply voltage range: 5V ~ 18V
- Over current protection
- Thermal shutdown
- Thermal alarm (SOP8 only)
- LED open detection (SOP8 only)

Applications

- LED architectural or entertainment lighting
- LED general or specialty illumination
- LED backlighting applications

Package Types

- TO-252 or SOP8 (with thermal pad)

Block Diagram

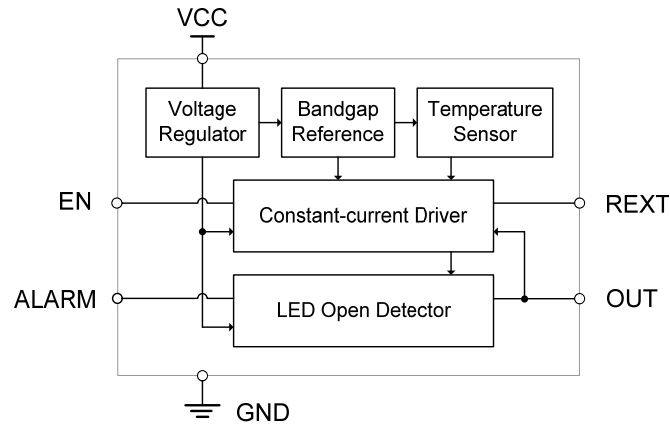

Pin Connection

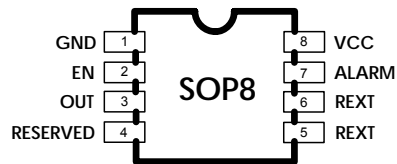
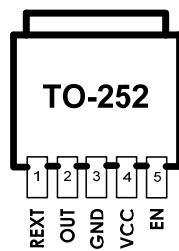

Pin Description

PIN No.	PIN NAME	FUNCTION
TO252:3/SOP8:1	GND	Ground terminal.
TO252:5/SOP8:2	EN	Output current enable terminal.
TO252:2/SOP8:3	OUT	Sink constant current outputs (open-drain).
SOP8:4	RESERVED	Terminal for testing, user should leave this pin open.
TO252:1/SOP8:5,6	REXT ^{*1}	External resistor connected between REXT and GND for driver current value setting.
SOP8:7	ALARM	Output open drain terminal: (connected to a pull-high resistor) 'H' for normal conditions, 'L' for LED open or chip overheated.
TO252:4/SOP8:8	VCC	Power supply terminal.

*1 Notice that both REXT pins (SOP8: pin5 and pin6) should be connected in PCB layout.



Maximum Ratings (Ta=25°C, Tj(max) = 125°C)

CHARACTERISTIC	SYMBOL	RATING	UNIT
Supply Voltage	VDD	-0.3 ~ 18	V
Input Voltage	VIN	-0.3 ~ VDD+0.3	
Output Current	Iout	1.0	A
Output Voltage	Vout	-0.3 ~ 18	V
Enable Voltage	VEN	-0.3 ~ 18	
Output Enable Frequency	FEN	1	MHz
GND Terminal Current	IGND	1.01	A
Power Dissipation	Pd	3.27 (TO-252) 1.67 (SOP8)	W
Thermal Resistance (Junction to Air)	Rth(j-a) *1	30.6 (TO-252) 60 (SOP8)	°C/W
Operating Temperature	Top	-40 ~ 85	°C
Storage Temperature	Tstg	-55 ~ 150	

Recommended Operating Condition

CHARACTERISTIC	SYMBOL	CONDITION	MIN.	TYP.	MAX.	UNIT
Supply Voltage	VDD	—	5.0	—	18	V
Output Voltage	Vout	Driver On *2	1.0	—	—	V
		Driver Off *3	—	—	18	
Output Current	Iout	OUT	—	—	1.0	A
Input Enable Voltage	VIH	VDD = 5V ~ 18V	3.0	—	18	V
	VIL		-0.3	—	1.0	
Input Enable Frequency	FEN	Ven > 3.0V	DC	—	1	MHz

*1 Base on JEDEC high conductivity test board (4-layer) simulation.

*2 Notice that the power dissipation is limited to its package and ambient temperature.

*3 The driver output voltage including any overshoot stress has to be compliant with the maximum voltage (18V).



Electrical Characteristics (Ta = 25°C unless otherwise noted)

CHARACTERISTIC	SYMBOL	CONDITION	MIN.	TYP.	MAX.	UNIT
Input Enable Voltage "H" Level	V _{EN(H)}	VDD = 5V ~ 18V	3.0	—	18	V
Input Enable Voltage "L" Level	V _{EN(L)}		-0.3	—	1.0	
Output Leakage Current	I _{OL}	V _{out} = 18 V V _{en} = 0 V	—	—	1.0	uA
Output Current Skew (Chip-to-Chip) *1	I _{OL1}	V _{out} = 1.0 V REXT = 10 Ω	—	—	± 5	%
Output Voltage Regulation	% / V _{out}	REXT = 0.5 Ω V _{out} = 0.8 V ~ 3 V	—	0.1	1	% / V
Supply Voltage Regulation	% / VDD	REXT = 0.5 Ω	—	—	2	
Alarm threshold temperature	T _{alm}	REXT = 0.5 KΩ	—	110	—	°C
Shutdown threshold temperature	T _{std}		—	180	—	°C
Supply Current *2	I _{DD1}	VDD = 5 V REXT = 0.5 Ω	—	1.2	—	mA
	I _{DD2}	VDD = 12 V REXT = 0.5 Ω	—	2.0	—	
	I _{DD3}	VDD = 18 V REXT = 0.5 Ω	—	2.8	—	

*1 Chip-to-Chip skew is defined as the range into which any output current of any IC falls.

*2 IO excluded.

Switching Characteristics (Ta = 25°C unless otherwise noted)

CHARACTERISTIC		SYMBOL	CONDITION	MIN.	TYP.	MAX.	UNIT
Propagation Delay ('L' to 'H')	EN-to-OUT (Driver On)	tpLH	VIH = VDD	—	166	—	ns
Propagation Delay ('H' to 'L')	EN-to-OUT (Driver Off)	tpHL	VIL = GND REXT = 0.5 Ω	—	150	—	
Output Current Rise Time		tor	VL = 5.0 V RL = 8 Ω	—	270	—	
Output Current Fall Time		tof	CL = 13 pF	—	140	—	

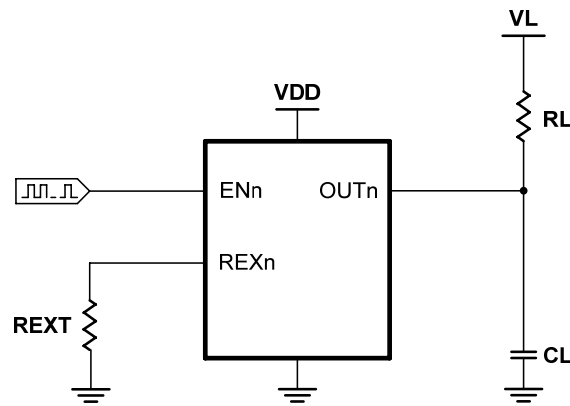

Switching Characteristics Test Circuit

Transient Characteristics

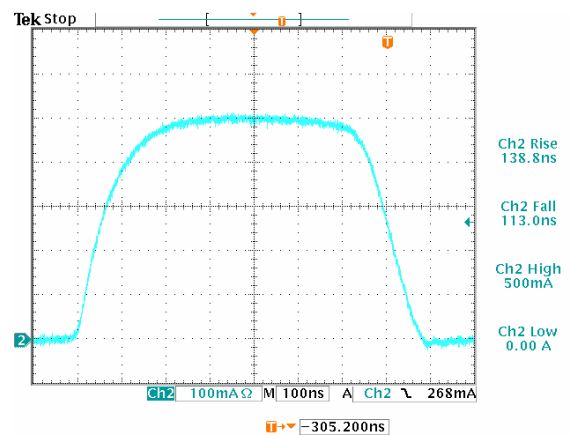
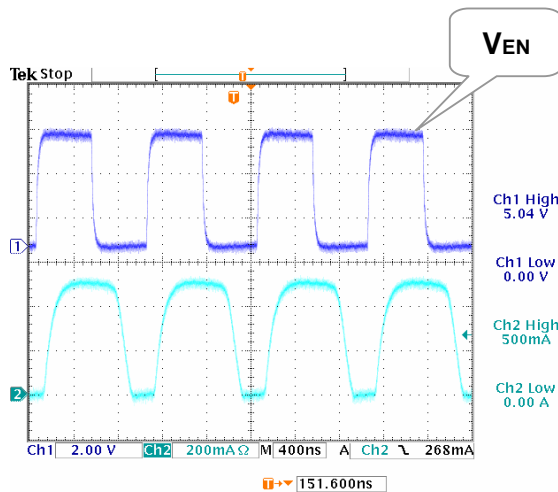

Constant-Current Output

Constant-current value of each output channel is set by an external resistor connected between the REXT pin and GND. Varying the resistor value can adjust the current up to 1A. Notice that the output current is a little increasing or decreasing until the device temperature and ambient temperature are balance. The maximum power dissipation of the determined external resistor should be large enough than the actual power consumption: $0.5(V) \times I_{out}(A)$ need to be considered. Approximate output current value can be calculated by following equation:

$$I_{OUT}(A) \simeq 0.5 (V) / R_{EXT}(\Omega)$$

Output Current as a Function of REXT value

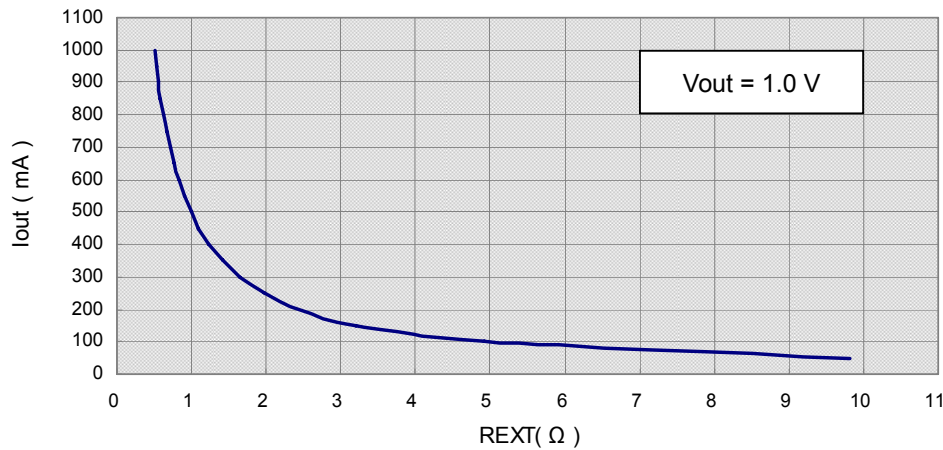

Output Current as a Function of Output Voltage

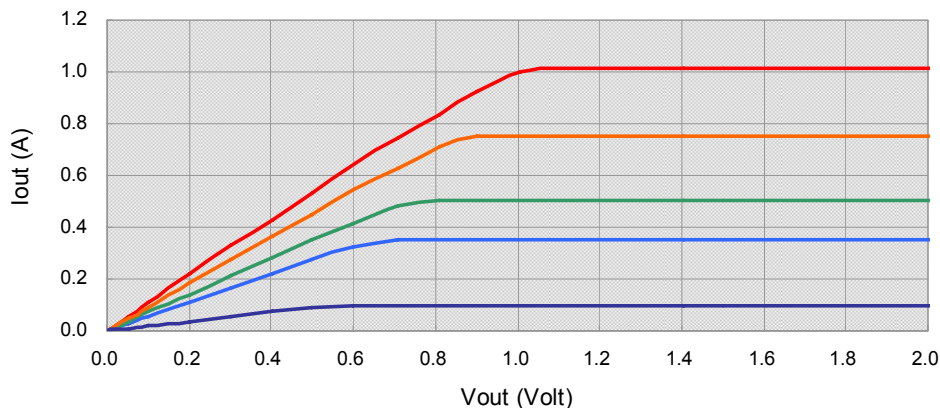

Alarm Function (SOP8 Only)

It can detect the operating status by connecting a pull-high resistor to the open-drain ALARM pin. The ALARM pin is kept 'H' for normal conditions, and shifted to 'L' if there is any failure like LED open, overheating or both occurrence. User can determine the different status from the truth table below:

ALARM	EN	Status
H	don't care	Normal Operation
H→L	H	LED Open or Thermal issue
H→L	L	Thermal Alarm or Shutdown

Thermal Alarm and Shutdown

During operation, when the junction temperature of the IC will reach about 110°C, the ALARM pin will shift to low level and produce a warning signal. Suggested cooling measures is to start the fan, lower the output currents and etc. If no cooling measures were activated, the junction temperature might continue to rise. Once it reaches approximately above 180°C, it will cause the driver to shutdown all the outputs. Basically, the IC will cool down and return to the safe operating temperature which is approximately below 110°C. The ALARM pin will reset to high level, disable the warning, and restart all the outputs at the same time. Operation in the thermal situation for a long time may cause chip damage permanently.

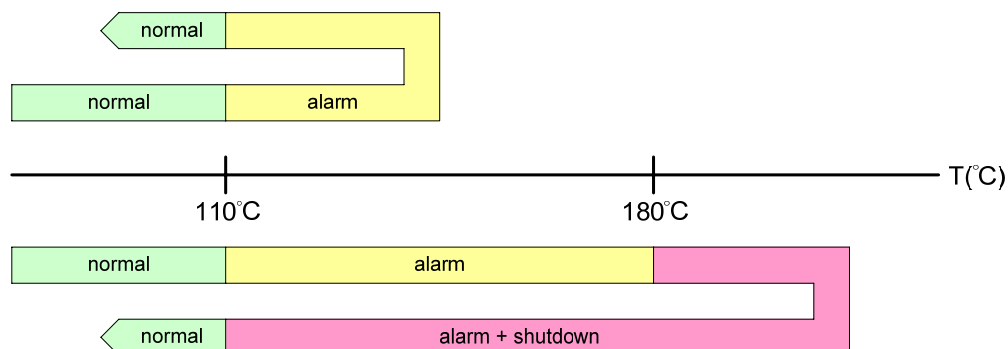

Relations between Alarm Function and Junction Temperature

Power Dissipation

Notice that the power dissipation of a semiconductor chip is limited to its package and ambient temperature, in which the device requires the maximum output current calculated for given operating conditions. The maximum allowable power consumption can be calculated by the following equation:

$$Pd(max)(Watt) = \frac{Tj(junction\ temperature)(max)(^{\circ}C) - Ta(ambient\ temperature)(^{\circ}C)}{Rth(junction-to-air\ thermal\ resistance)(^{\circ}C/Watt)}$$

The relationship between power dissipation and operating temperature can be refer to the figure below:

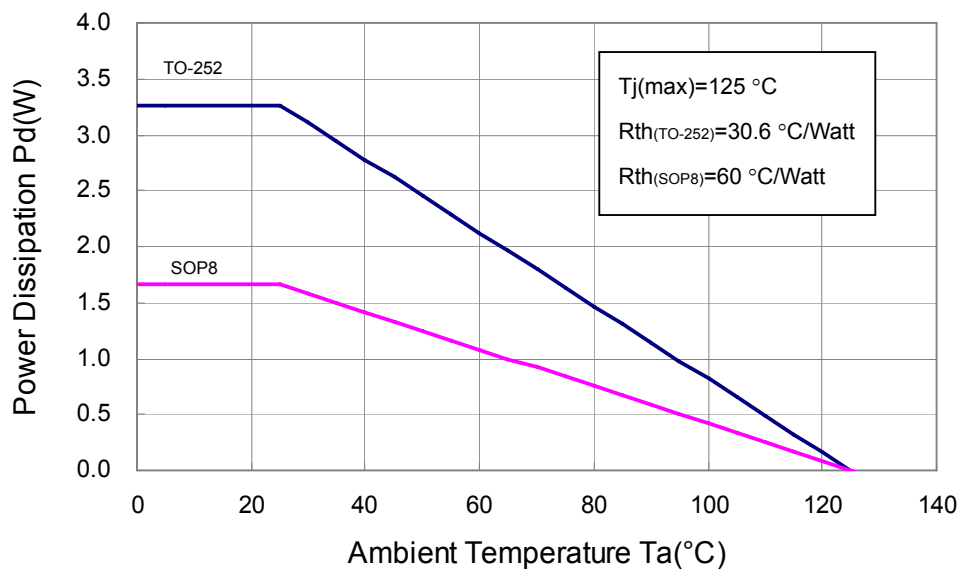

Based on the Pd(max), the maximum allowable voltage of output terminal can be determined by the following equation:

$$Vout(max)(Volt) = \frac{Pd(max)(Watt) - VDD(Volt) \times IDD(A)}{Iout(A) \times Dimming\ Duty}$$

Typical Application

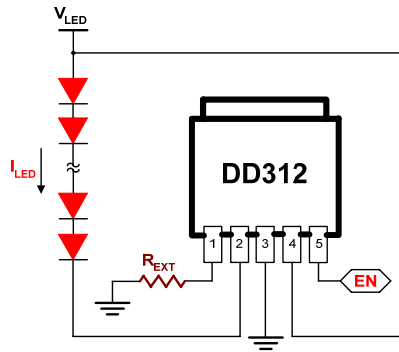

Series String (Suggested)

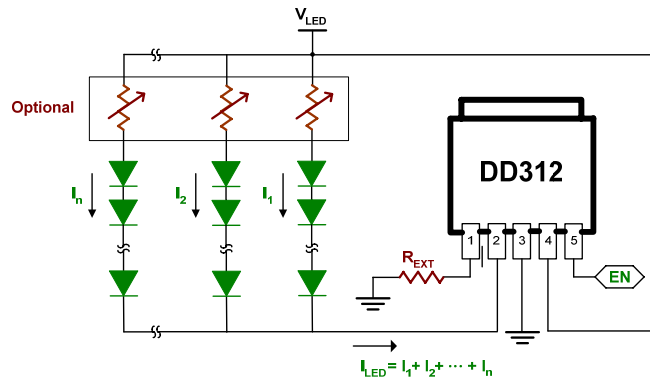

Paralleled Strings

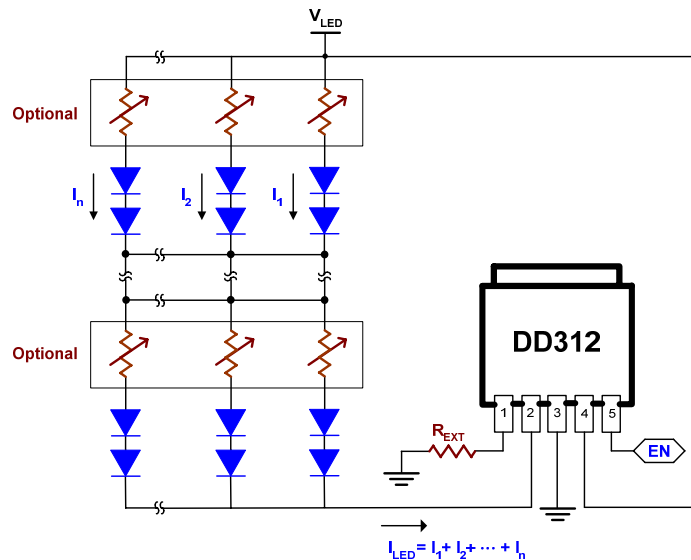

Cross Connected Paralleled Strings

Typical Application

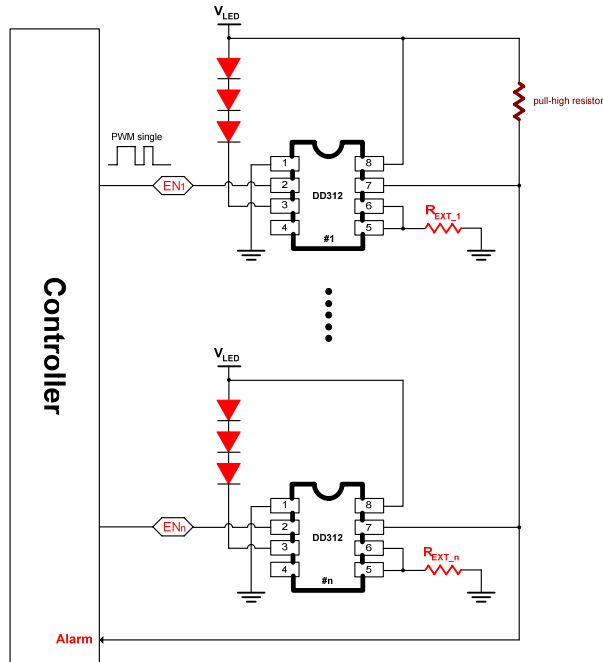

Feedback Alarm signal with only one pull-high resistor

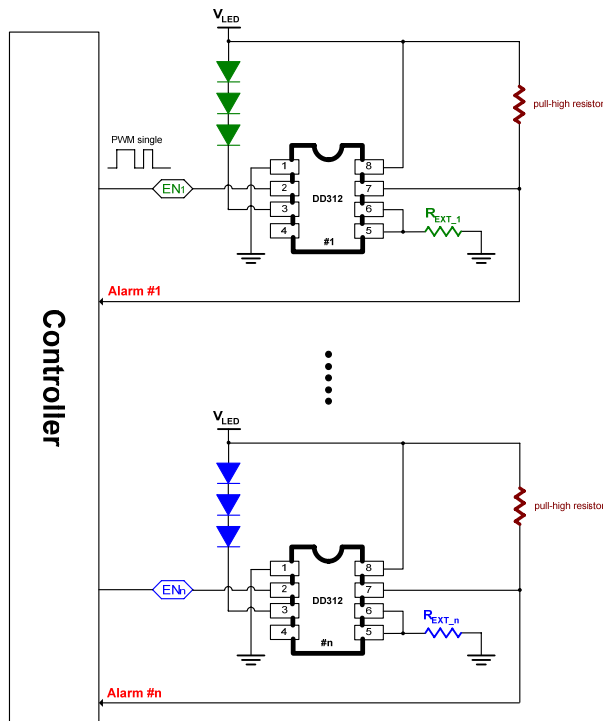

Independent feedback Alarm signal

Typical Application

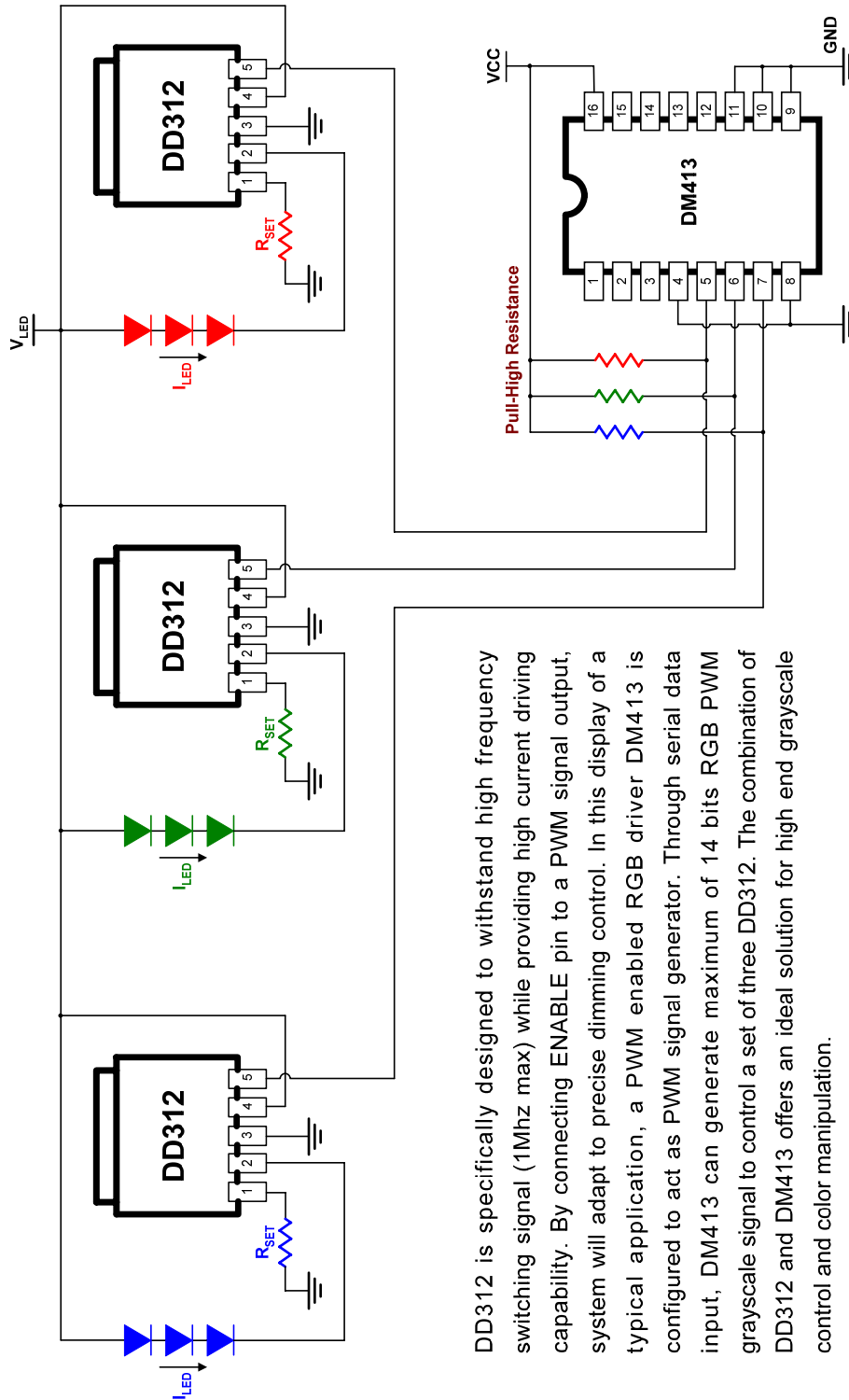

DD312 is specifically designed to withstand high frequency switching signal (1Mhz max) while providing high current driving capability. By connecting ENABLE pin to a PWM signal output, a system will adapt to precise dimming control. In this display of a typical application, a PWM enabled RGB driver DM413 is configured to act as PWM signal generator. Through serial data input, DM413 can generate maximum of 14 bits RGB PWM grayscale signal to control a set of three DD312. The combination of DD312 and DM413 offers an ideal solution for high end grayscale control and color manipulation.



Package Outline Dimension

TO-252

Unit: inch/mm

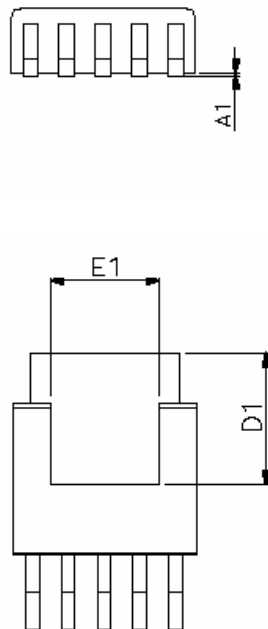
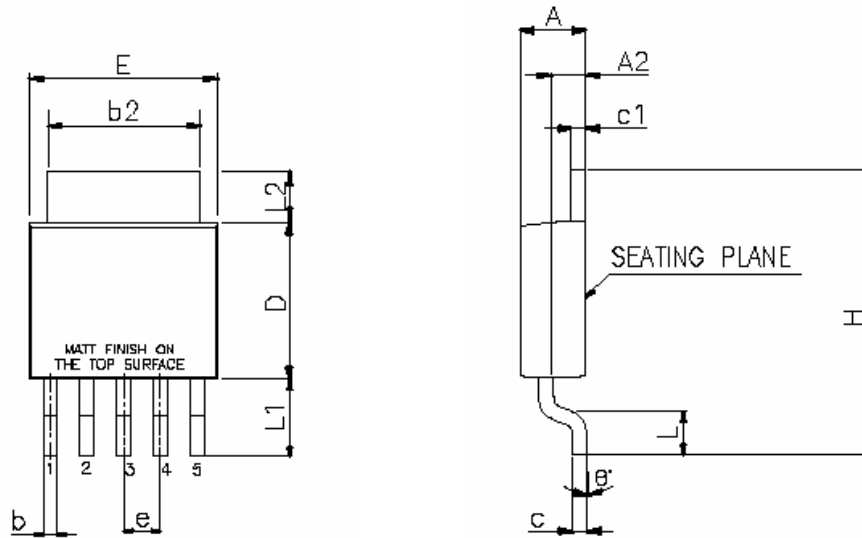

SYMBOLS	DIMENSIONS IN INCH		DIMENSIONS IN MM	
	MIN.	MAX.	MIN.	MAX.
A	0.086	0.094	2.184	2.388
A1	0.000	0.005	0.000	0.127
A2	0.040	0.050	1.016	1.270
b	0.020 TYP		0.508 TYP	
b 2	0.205	0.215	5.207	5.461
c	0.018	0.023	0.457	0.584
c 1	0.018	0.023	0.457	0.584
D	0.210	0.220	5.334	5.588
D1	0.180	-	4.572	-
E	0.250	0.265	6.350	6.731
E1	0.150	-	3.810	
e	0.050 BSC		1.270 BSC	
H	0.370	0.410	9.398	10.414
L	0.055	0.070	1.397	1.778
L1	0.105 REF		2.667 REF	
L2	0.06	0.08	1.524	2.032
theta	0°	4°	0°	4°

Package Outline Dimension

SOP8 (exposed pad)

Unit: inch

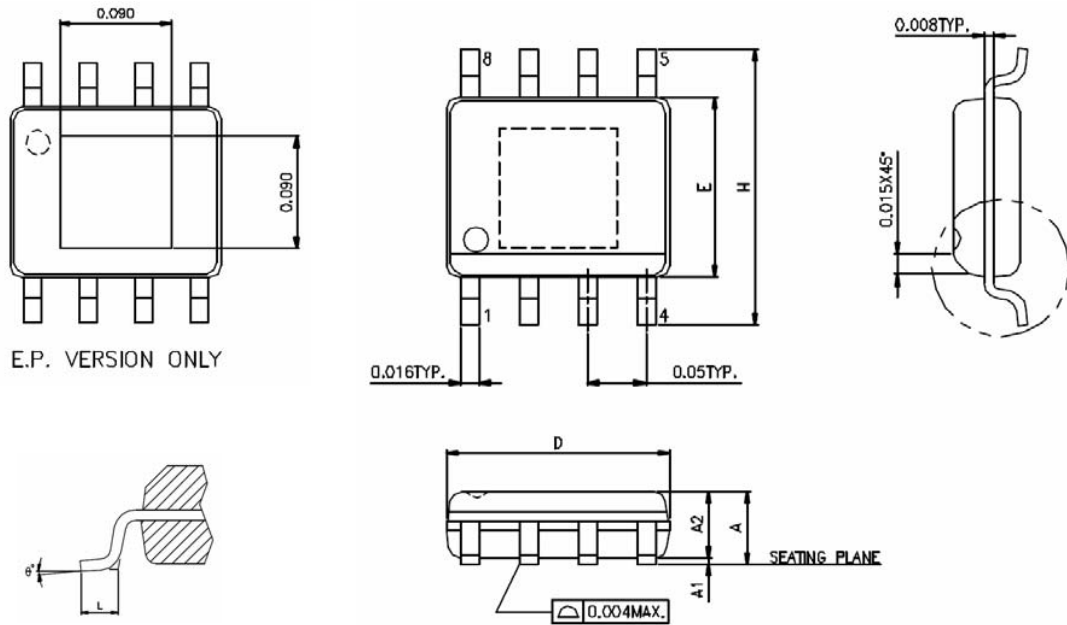

SYMBOLS	MIN.	MAX.
A	0.053	0.069
A1	0.004	0.010
A2	—	0.059
D	0.189	0.196
E	0.150	0.157
H	0.228	0.244
L	0.016	0.050
θ°	0	8

UNIT : INCH



Product Ordering Information

Part Number	Package Type	Number / Weight (typ.)	
		Tube / Tray	Reel (Box included)
DD312-SOP	SOP8-150-1.27	100pcs / Tube 0.018kg \pm 5%	—
DD312-TO252EX	TO252-1.27 (Exposed Pad)	80pcs / Tube 0.045kg \pm 5%	—

DD312-SOP Package and Weight (4 Boxes Set)

SOP8 - 150 - 1.27

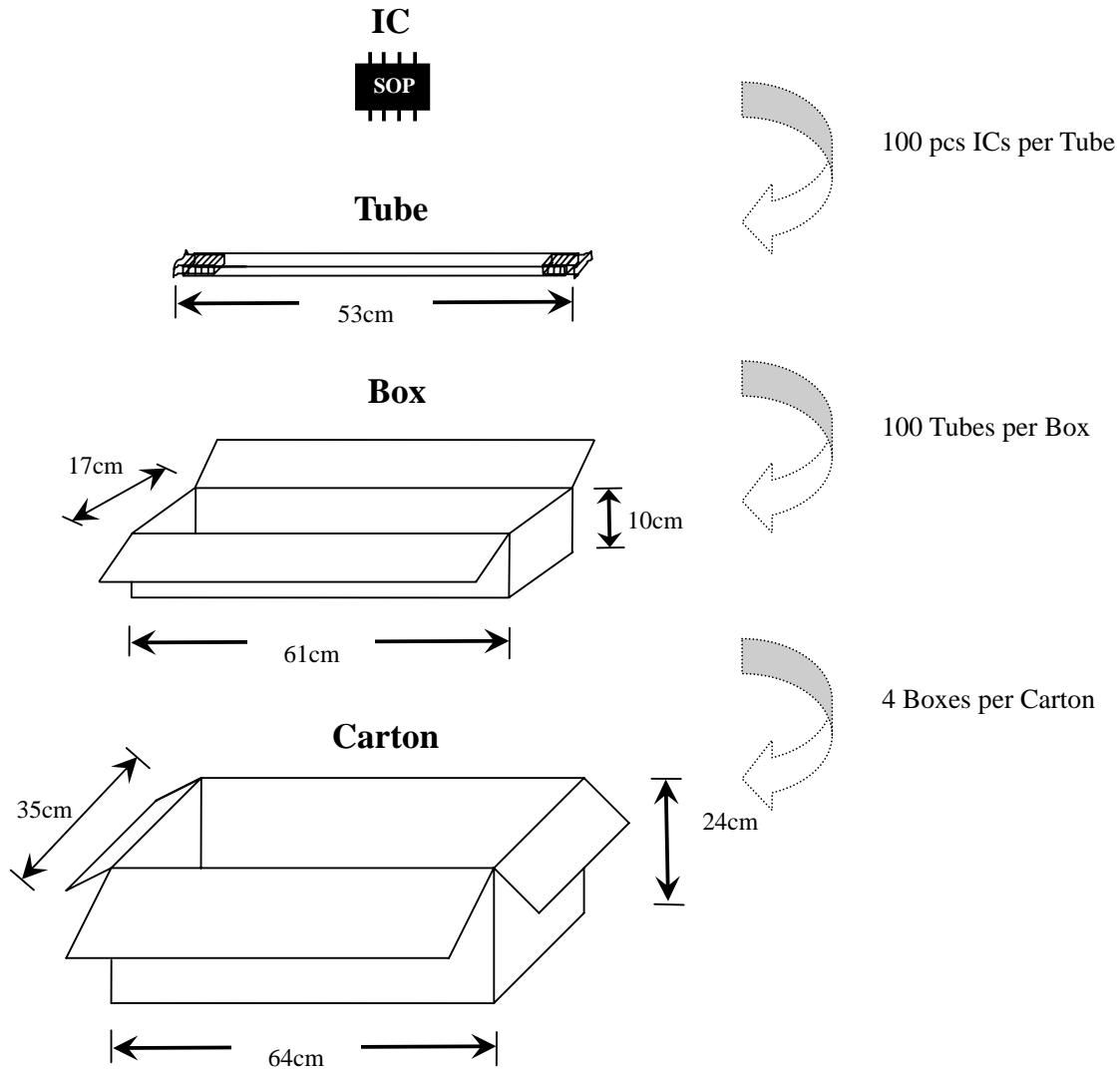

Weight

Item	Description	Weight (Kg)
1	100 pcs DD312-SOP per Tube	0.018±5%
2	Net Weight of one Box	0.40±5%
3	Net Weight of one Carton	1.24±5%
4	Per Carton Set (4 Boxes, 40,000 pcs)	10.04±5%

DD312-SOP Package and Weight (6 Boxes Set)

SOP8 - 150 - 1.27

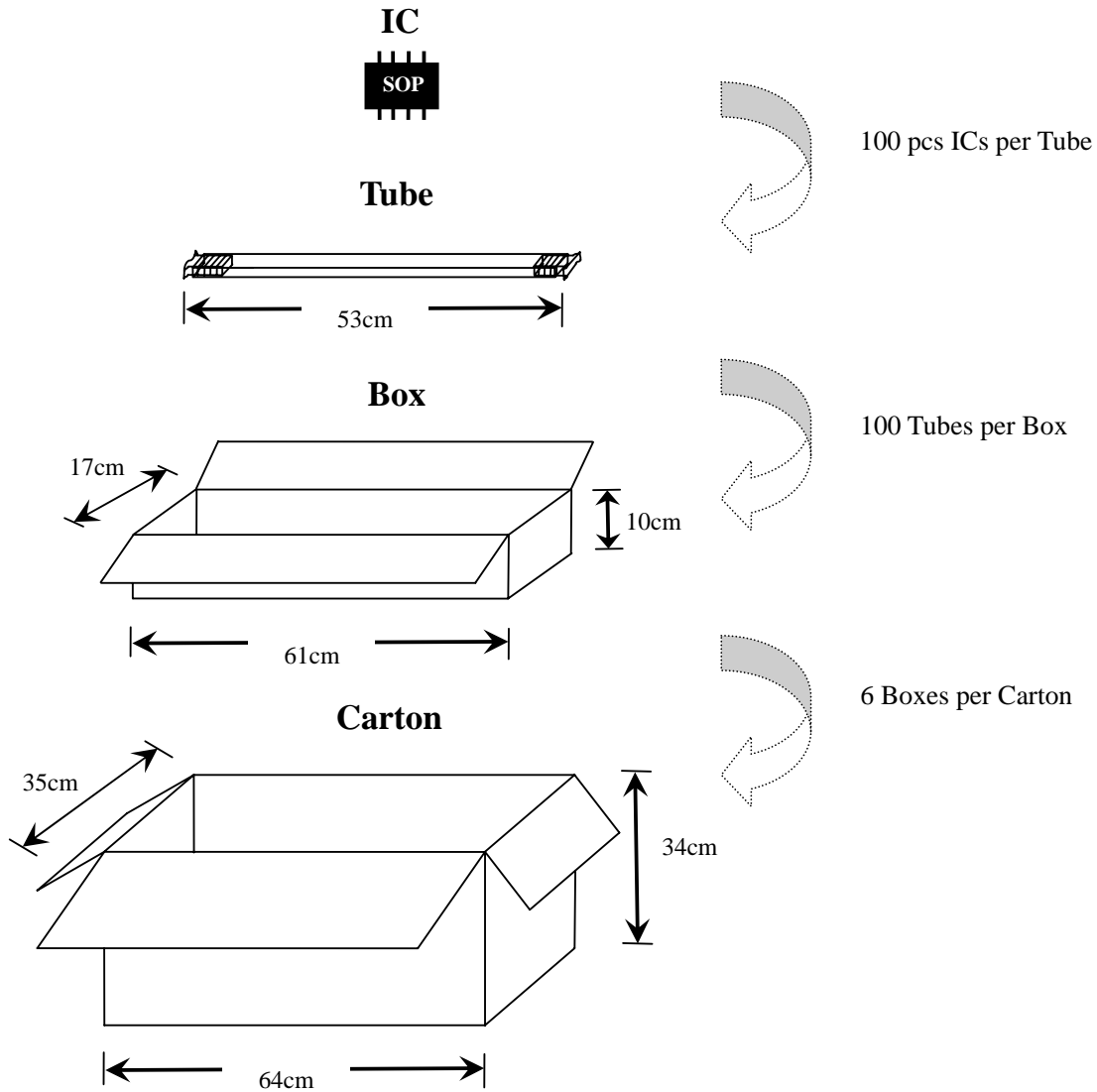

Weight

Item	Description	Weight (Kg)
1	100 pcs DD312-SOP per Tube	0.018±5%
2	Net Weight of one Box	0.40±5%
3	Net Weight of one Carton	1.44±5%
4	Per Carton Set (6 Boxes, 60,000 pcs)	14.64±5%

DD312-TO252EX Package and Weight (4 Boxes Set)

TO252 - 1.27 (Exposed Pad)

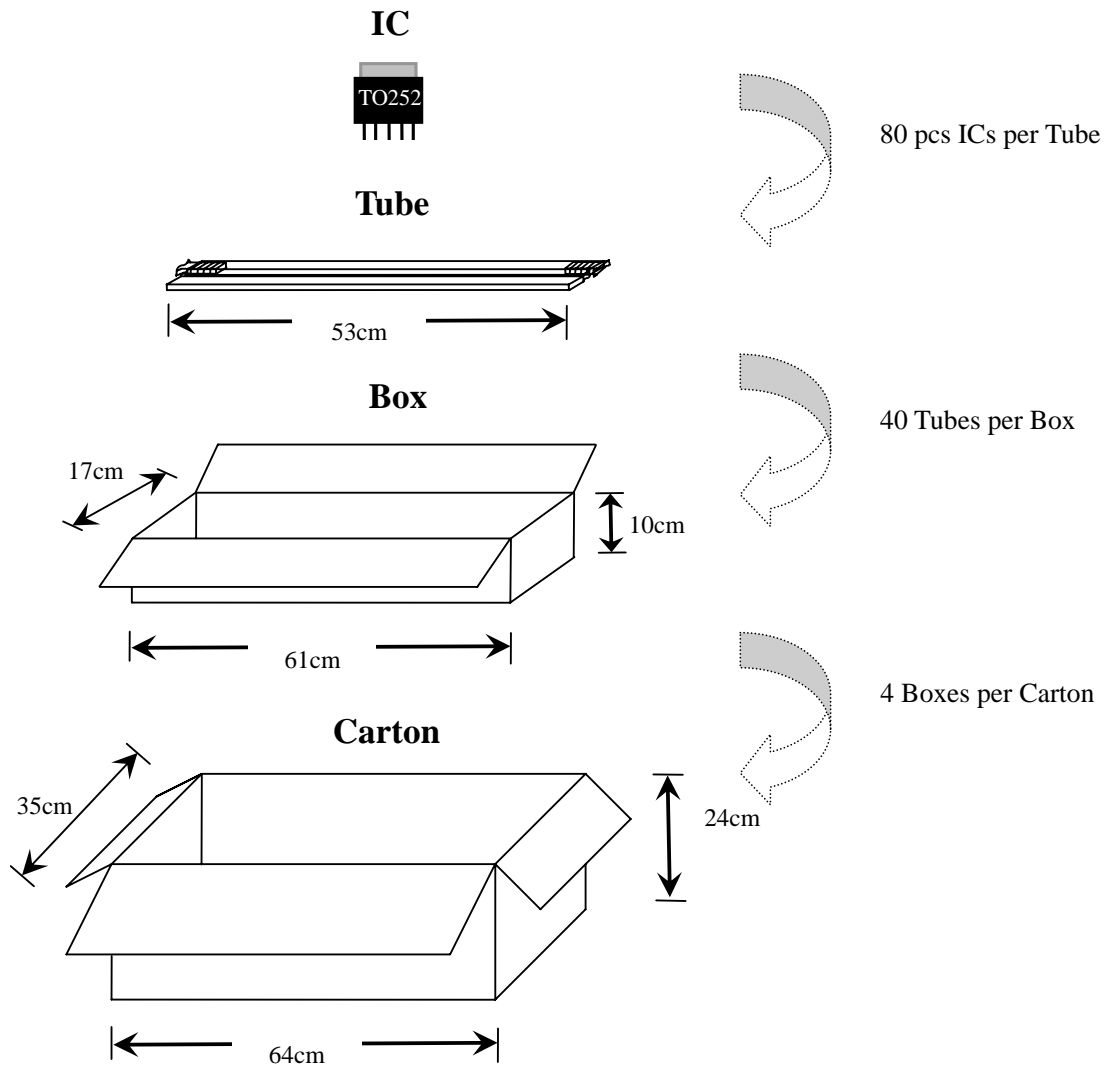

Weight

Item	Description	Weight (Kg)
1	80 pcs DD312-TO252EX per Tube	0.045±5%
2	Net Weight of one Box	0.40±5%
3	Net Weight of one Carton	1.24±5%
4	Per Carton Set (4 Boxes, 12,800 pcs)	10.04±5%

DD312-TO252EX Package and Weight (6 Boxes Set)

TO252 - 1.27 (Exposed Pad)

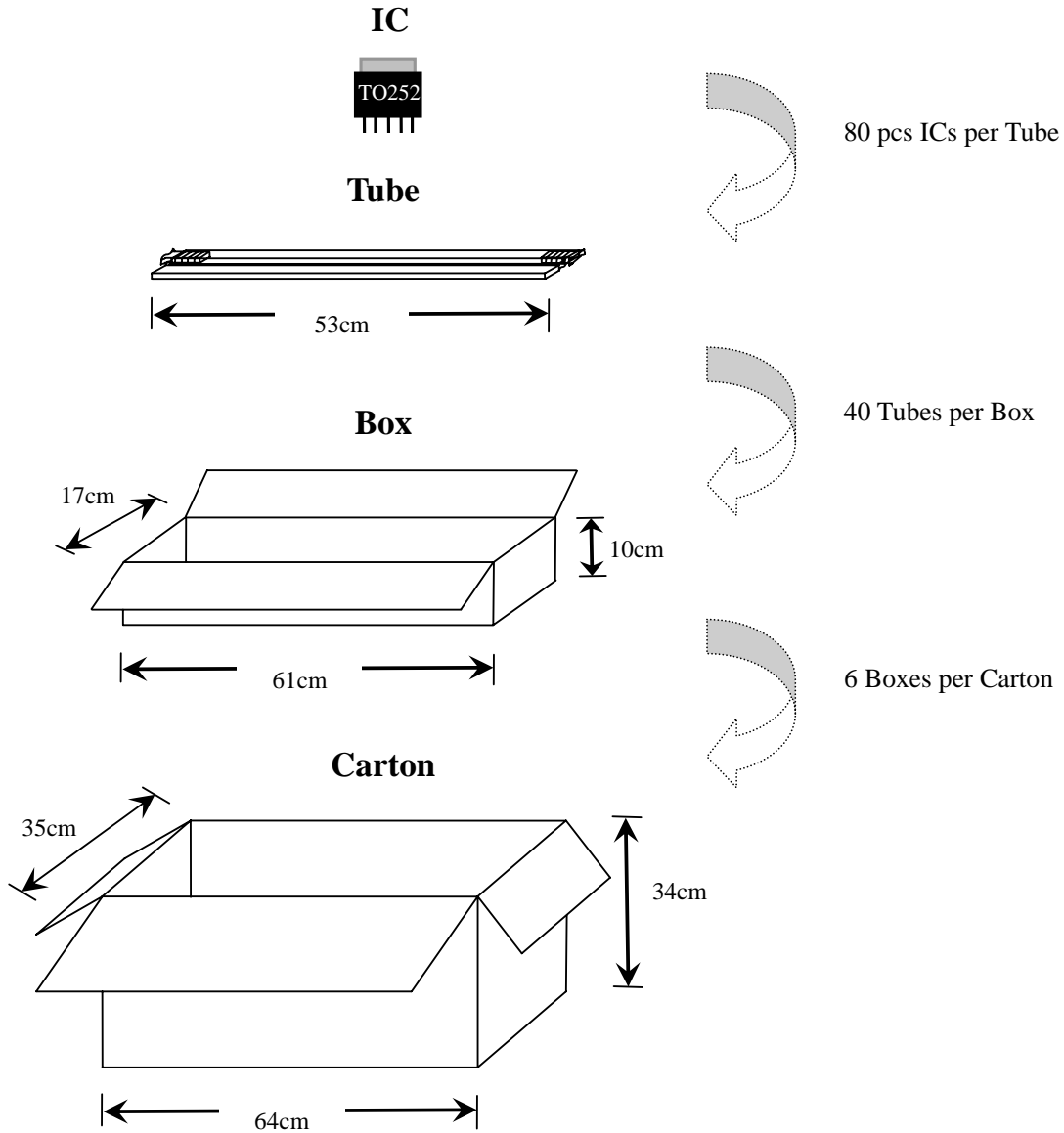

Weight

Item	Description	Weight (Kg)
1	80 pcs DD312-TO252EX per Tube	0.045±5%
2	Net Weight of one Box	0.40±5%
3	Net Weight of one Carton	1.44±5%
4	Per Carton Set (6 Boxes, 19,200 pcs)	14.64±5%



The products listed herein are designed for ordinary electronic applications, such as electrical appliances, audio-visual equipment, communications devices and so on. Hence, it is advisable that the devices should not be used in medical instruments, surgical implants, aerospace machinery, nuclear power control systems, disaster/crime-prevention equipment and the like. Misusing those products may directly or indirectly endanger human life, or cause injury and property loss.

Silicon Touch Technology, Inc. will not take any responsibilities regarding the misuse of the products mentioned above. Anyone who purchases any products described herein with the above-mentioned intention or with such misused applications should accept full responsibility and indemnify. Silicon Touch Technology, Inc. and its distributors and all their officers and employees shall defend jointly and severally against any and all claims and litigation and all damages, cost and expenses associated with such intention and manipulation.