



Data Sheet

VI-ARM™

Autoranging Rectifier Modules

Up to 1500 Watts



Actual size:
2.28 x 1.45 x 0.5 in
57,9 x 36,8 x 12,7 mm

Features

- RoHS Compliant (with F or G pin option)
- Autoranging input
- Microprocessor controlled
- VI-ARM-C1:
500 W @ 90 – 132 Vac
750 W @ 180 – 264 Vac
- VI-ARMB-C2:
750 W @ 115 Vac
1500 W @ 230 Vac
- 96 – 98% efficiency
- 100°C baseplate (no derating)
- cULus, cTUVus, CE Marked
- AC Bus OK, module enable
- Inrush limiting (no external circuitry)
- CE Marked

Typical Applications: systems requiring a rugged, full featured interface to the AC mains in the smallest possible package.

Product Highlights

The ARM (Autoranging Rectifier Module) is an AC front end module which provides autoranging line rectification and inrush current limiting. The ARM is available in either 500/750 W or 750/1500 W models in a quarter brick package measuring only 2.28" x 1.45" x 0.5".

The ARM interfaces directly with worldwide AC mains and may be used with Vicor 300 V input DC-DC converters to realize an autoranging, high density, low profile switching power supply. The ARM includes a microcontroller that continuously monitors the AC line to control bridge/doubler operation. The user need only provide external capacitance to satisfy system hold-up requirements.

Vicor Micro series packaging technology offers flexible mounting options for various manufacturing processes. The ARM may be installed as a conventional leaded device for on-board applications, in-board for low profile, height restricted applications, socketed or surface mounted with optional ModuMate interconnect products.

Absolute Maximum Ratings

Parameter	Rating	Unit	Notes
L to N	264	Vac	
	280	Vac	100 ms
+Out to –Out	400	Vdc	
B OK to –Out	16	Vdc	
EN to –Out	16	Vdc	
Output power			
VI-ARM	500/750	Watts	115/230 V
VI-ARMB	750/1500	Watts	115/230 V See page 3 for derating
Mounting torque	4 – 6 (0.45 – 0.68)	in-lbs (N-m)	6 each, 4-40 screw
Operating temperature	–55 to +100	°C	M-Grade
Storage temperature	–65 to +125	°C	M-Grade
Pin soldering temperature	500 (260)	°F (°C)	<5 sec; wave solder
	750 (390)	°F (°C)	<7 sec; hand solder

Thermal Resistance Capacity

Parameter	Min	Typ	Max	Unit
Baseplate to sink				
flat, greased surface		0.24		°C/Watt
with thermal pad (P/N 16495)		0.3		°C/Watt
Baseplate to ambient				
free convection		15		°C/Watt
1000 LFM		2.7		°C/Watt
Thermal capacity		48		Watt-sec/°C

Part Numbering

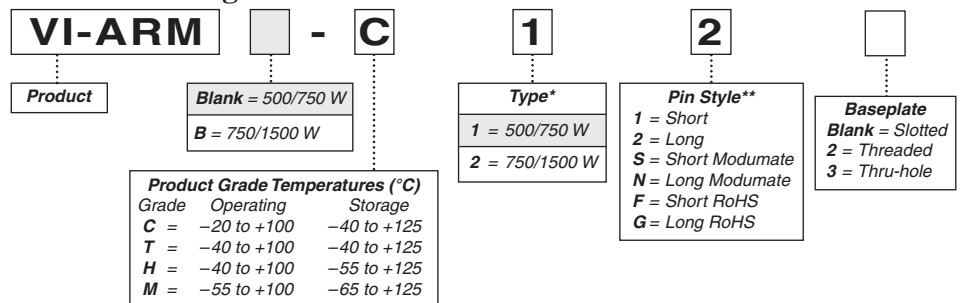

*Type 1 only refers to the VI-ARM; Type 2 refers to VI-ARMB

**Pin styles S, N, F & G are compatible with the ModuMate interconnect system for socketing and surface mounting.

ELECTRICAL CHARACTERISTICS

Electrical characteristics apply over the full operating range of input voltage, output load (resistive) and baseplate temperature, unless otherwise specified. All temperatures refer to the operating temperature at the center of the baseplate. Specifications apply for AC mains having up to 5% total harmonic distortion.

■ INPUT SPECIFICATIONS

Parameter	VI-ARM - 1			VI-ARMB - 2			Unit	Notes
	Min	Typ	Max	Min	Typ	Max		
Operating input voltage	90		132	90		132	Vac	Autoranging (doubler mode)
	180		264	180		264	Vac	Autoranging (bridge mode)
Input undervoltage			90			90	Vac	No damage
Input surge withstand			280			280	Vac	100 ms
AC line frequency	47		63	47		63	Hz	C-Grade
	47		880	47		880	Hz	T, H & M-Grade
Input current, rms	0		7.4	0		11.1	Amps	120 Vac
	0		5.4	0		7.2	Amps	240 Vac
Power factor	0.60			0.60				Typical line voltage condition
Inrush current			30			30	Amps	264 Vac peak line, cold start
Holdup Capacitance			1600			2400	μF	

■ OUTPUT SPECIFICATIONS

Parameter	VI-ARM - 1			VI-ARMB - 2			Unit	Notes
	Min	Typ	Max	Min	Typ	Max		
Output power	0		500	0		750	Watts	105 – 132 Vac (Fig. 1)
	0		750	0		1500	Watts	210 – 264 Vac (Fig. 2)
Efficiency								
	120 Vac	94	96	94	96		%	
240 Vac	96	98	96	98		%		
Output voltage	200		375	200		375	Vdc	90 – 264 Vac

■ CONTROL PIN SPECIFICATIONS

Parameter	Min	Typ	Max	Unit	Notes
AC Bus OK (B OK)					
On-state resistance (low)			15	Ω	To negative output - bus normal
On-state current (low)			-50	mA	Bus normal
Off-state voltage	14.8	15.0	15.2	Vdc	Bus abnormal, 27 K internal pull up to 15 Vdc (Fig. 12)
On-state threshold	235	240	245	Vdc	Output bus voltage
Off-state threshold	200	205	210	Vdc	Output bus voltage
Module Enable (EN)					
On-state resistance (low)			15	Ω	To negative output - converters are disabled
On-state current (low)			50	mA	
Off-state voltage	14.8	15.0	15.2	Vdc	150 K internal pull up to 15 Vdc (Fig. 11)
On-state threshold	235	240	245	Vdc	Output bus voltage
Off-state threshold	185	190	195	Vdc	Output bus voltage
Over voltage shutdown	380	390	400	Vdc	
AC Bus OK - module enable, differential error*	15	17	20	Vdc	AC Bus OK and module enable thresholds track

* Tracking error between BUS OK and Enable thresholds

ELECTRICAL CHARACTERISTICS (CONT.)

SAFETY SPECIFICATIONS

Parameter	Min	Typ	Max	Unit	Notes
Isolation voltage (in to out)		None			Isolation provided by DC-DC converter(s)
Dielectric withstand (I/O to baseplate)	1,500			V _{RMS}	
Leakage current			100	μA	No filter

AGENCY APPROVALS

Safety Standards	Agency Markings	Notes
ARM1 xxx UL60950, EN60950, CSA 60950	cTÜVus CE Marked	Baseplate earthed, fast acting line fuse, Bussman ABC10 Low voltage directive
ARM2 xxx UL60950, EN60950, CSA 60950	cTÜVus CE Marked	Baseplate earthed, fast acting line fuse, Bussman ABC15 Low voltage directive

GENERAL SPECIFICATIONS

Parameter	Min	Typ	Max	Unit	Notes
MTBF		>1,000,000		hours	25°C, ground benign
Baseplate material					Aluminum
Cover					Kapton insulated aluminum, plastic molded terminal blocks
Pin material					Copper, tin/lead solder dipped (solder pins) Gold plated nickel copper (Modumate and RoHS)
Weight		1.6 (45)		ounces (grams)	
Size		2.28 x 1.45 x 0.5 (57,9 x 36,8 x 12,7)		inches (mm)	

VI-ARMB DERATING

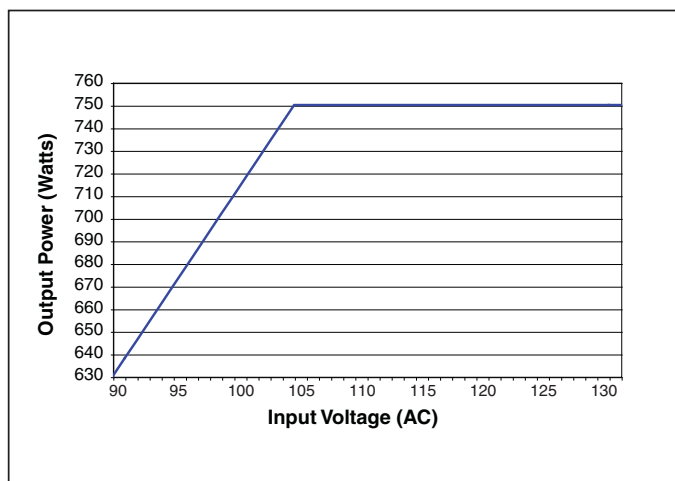

Figure 1 — 90 – 130 Vac ARMB output power rating

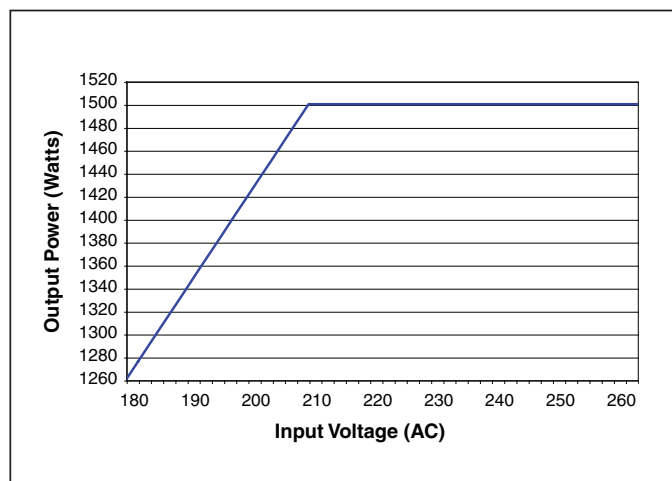

Figure 2 — 180 – 260 Vac ARMB output power rating

OPERATING CHARACTERISTICS

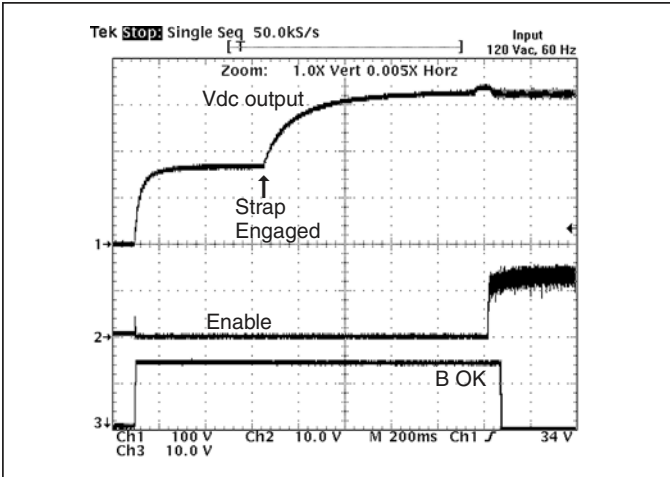

Figure 3 — Start-up at 120 Vac input

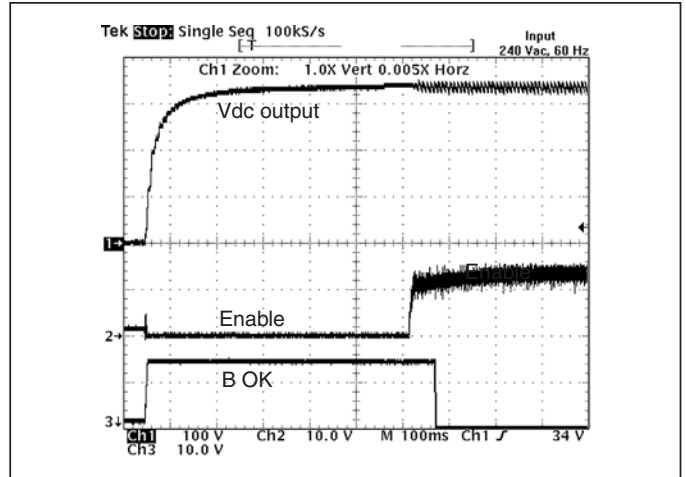

Figure 4 — Start-up at 240 Vac input

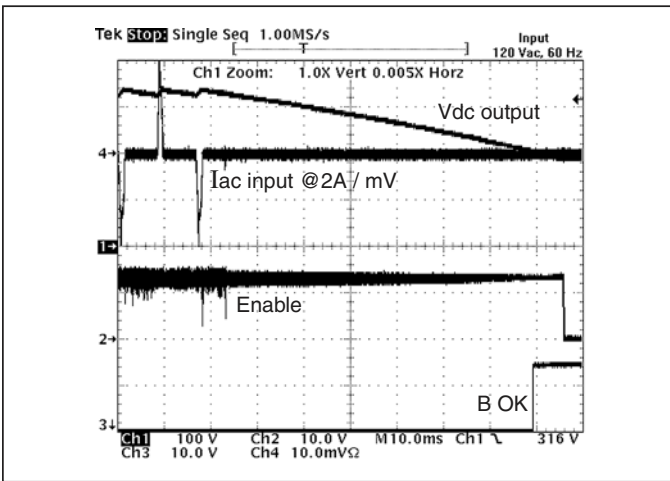

Figure 5 — Power down, from 120 Vac

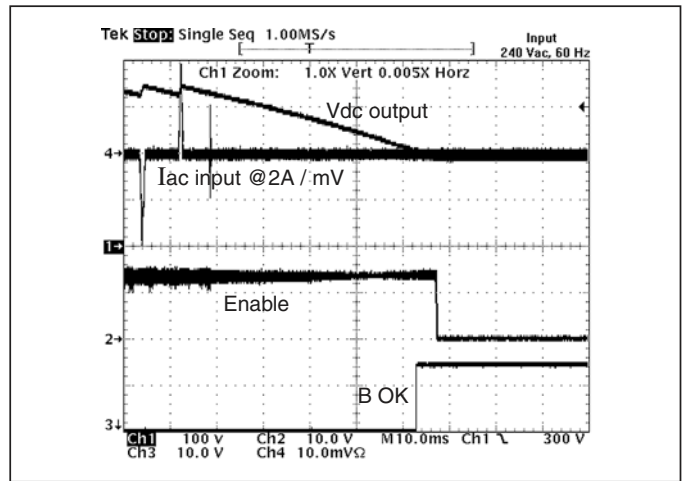

Figure 6 — Power down, from 240 Vac

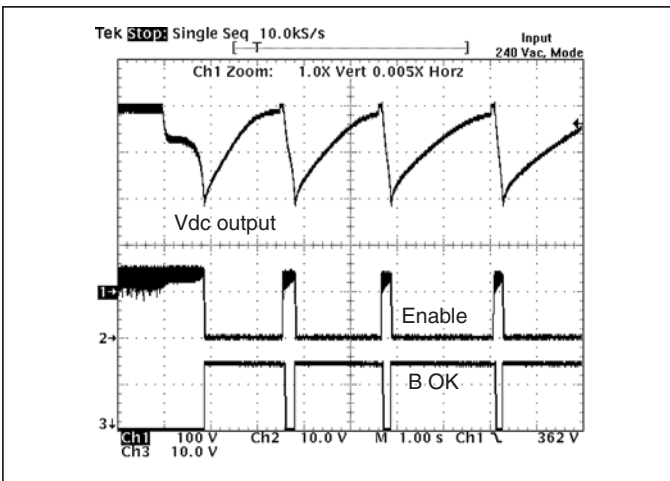

Figure 7 — Output overvoltage protection 240 Vac range

APPLICATION NOTE

The VI-ARM Autoranging Rectifier Module (ARM) provides an effective solution for the AC front end of a power supply designed with Vicor DC-DC converters. This high performance power system building block satisfies a broad spectrum of requirements and agency standards.

The ARM contains all of the power switching and control circuitry necessary for autoranging rectification, inrush current limiting, and overvoltage protection. This module also provides converter enable and status functions for orderly power up/down control or sequencing. To complete the AC front-end configuration, the user needs only to add holdup capacitors and a suitable input filter with transient protection.

Functional Description

Initial Conditions. The switch that bypasses the inrush limiting PTC (positive temperature coefficient) thermistor is open when power is applied, as is the switch that engages the strap for voltage doubling. (See Fig. 8). In addition, the downstream DC-DC modules are disabled via the Enable (EN) line, and Bus-OK (B OK) is high.

Power-Up Sequence. (See Fig. 9):

- 1.1** Upon application of input power, the output bus capacitors begin to charge. The thermistor limits the charge current, and the exponential time constant is determined by the holdup capacitor value and the thermistor cold resistance. The slope (dv/dt) of the capacitor voltage approaches zero as the capacitors become charged to the peak of the AC line voltage.

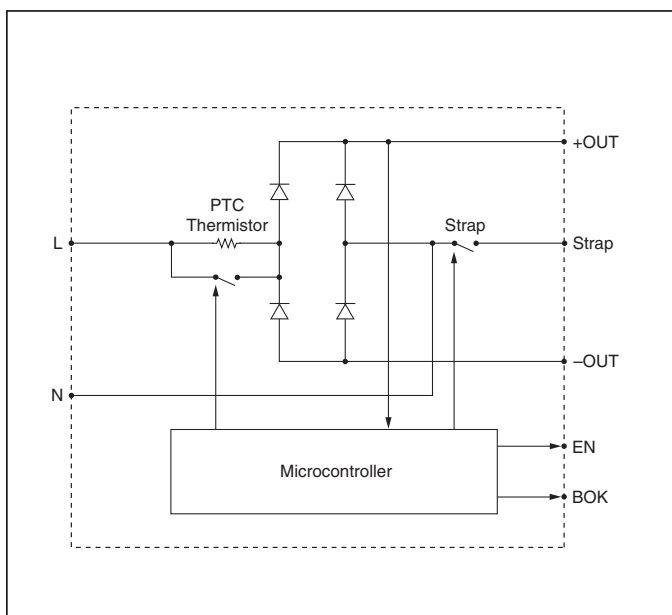

Figure 8 — Functional block diagram

- 2.1** If the bus voltage is less than 200 V as the slope nears zero, the voltage doubler is activated, and the bus voltage climbs exponentially to twice the peak line voltage. If the bus voltage is greater than 200 V, the doubler is not activated.
- 3.1** If the bus voltage is greater than 235 V as the slope approaches zero, the inrush limiting thermistor is bypassed. Below 235 V, the thermistor is not bypassed.
- 4.1** The converters are enabled ~150 milliseconds after the thermistor bypass switch is closed.
- 5.1** Bus-OK is asserted after an additional ~150 millisecond delay to allow the converter outputs to settle within specification.

Power-Down Sequence. (See Fig. 9). When input power is turned off or fails, the following sequence occurs as the bus voltage decays:

- 1.2** Bus-OK is deasserted when the bus voltage falls below 205 Vdc (Typ.).
- 2.2** The converters are disabled when the bus voltage falls below 200 Vdc. If power is reapplied after the converters are disabled, the entire power-up sequence is repeated. If a momentary power interruption occurs and power is reestablished before the bus reaches the disable threshold, the power-up sequence is not repeated.

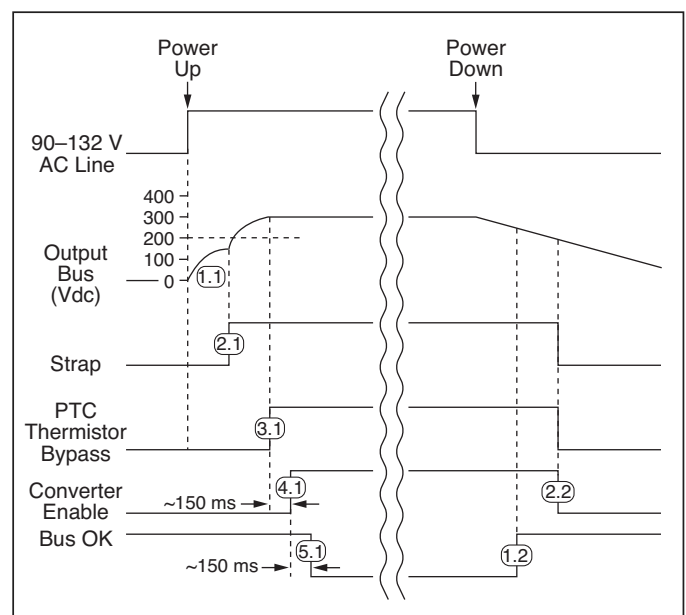

Figure 9 — Timing diagram: power up/down sequence

APPLICATION NOTE (CONT.)

Off-Line Power Supply Configuration

The ARM maintains the DC output bus voltage between 200 and 375 Vdc over the entire universal input range, this being compatible with Vicor VI-260 series and VI-J60 series DC-DC converters, as well as Vicors Maxi, Mini, Micro 300 V input Vicor converters. The ARM automatically switches to the proper rectification mode (doubled or undoubled) depending on the input voltage, eliminating the possibility of damage due to improper line connection. The VI-ARM-x1 is rated at 500 W in the low range (90-132 Vac input), and 750 W in the high range (180 – 264 Vac input). The VI-ARMB-x2 is rated for 750 W and 1500 W for the low and high input ranges respectively. Either of these modules can serve as the AC front end for any number and combination of compatible converters as long as the maximum power rating is not exceeded. See VI-ARMB derating curves. (Figures 1, and 2)

Strap (ST) Pin. In addition to input and output power pin connections, it is necessary to connect the Strap pin to the junction of the series holdup capacitors (C1, C2, Fig. 10) for proper (autoranging) operation. Varistors across the capacitors provide input transient protection. The bleeder resistors (R1, R2, Fig. 10) discharge the holdup capacitors when power is switched off.

Enable (EN) Pin. (See Fig. 11). The Enable pin must be connected to the Gate-In or PC pin of all converter modules to disable the converters during power-up. Otherwise, the

converters would attempt to start while the holdup capacitors were being charged through an un-bypassed thermistor, preventing the bus voltage from reaching the thermistor bypass threshold thus disabling the power supply. The Enable output (the drain of an N channel MOSFET) is internally pulled up to 15 V through a 150 kΩ resistor.

A signal diode should be placed close to and in series with the PC/Gate-In pin of each converter to eliminate the possibility of control interference between converters. The Enable pin switches to the high state (15 V) with respect to the negative output power pin to turn on the converters after the power-up inrush is over. The Enable function also provides input overvoltage protection for the converters by turning off the converters if the DC bus voltage exceeds 400 Vdc. The thermistor bypass switch opens if this condition occurs, placing the thermistor in series with the input voltage, which reduces the bus voltage to a safe level while limiting input current in case the varistors conduct. The thermistor bypass switch also opens if a fault or overload reduces the bus voltage to less than 180 Vdc.

CAUTION: There is no input to output isolation in the ARM, hence the –Out of the ARM and thus the –In of the downstream DC-DC converter(s) are at a high potential. If it is necessary to provide an external enable / disable function by controlling the DC-DC converter’s PC pin (referenced to the –In) of the converter an opto-isolator or isolated relay should be employed.

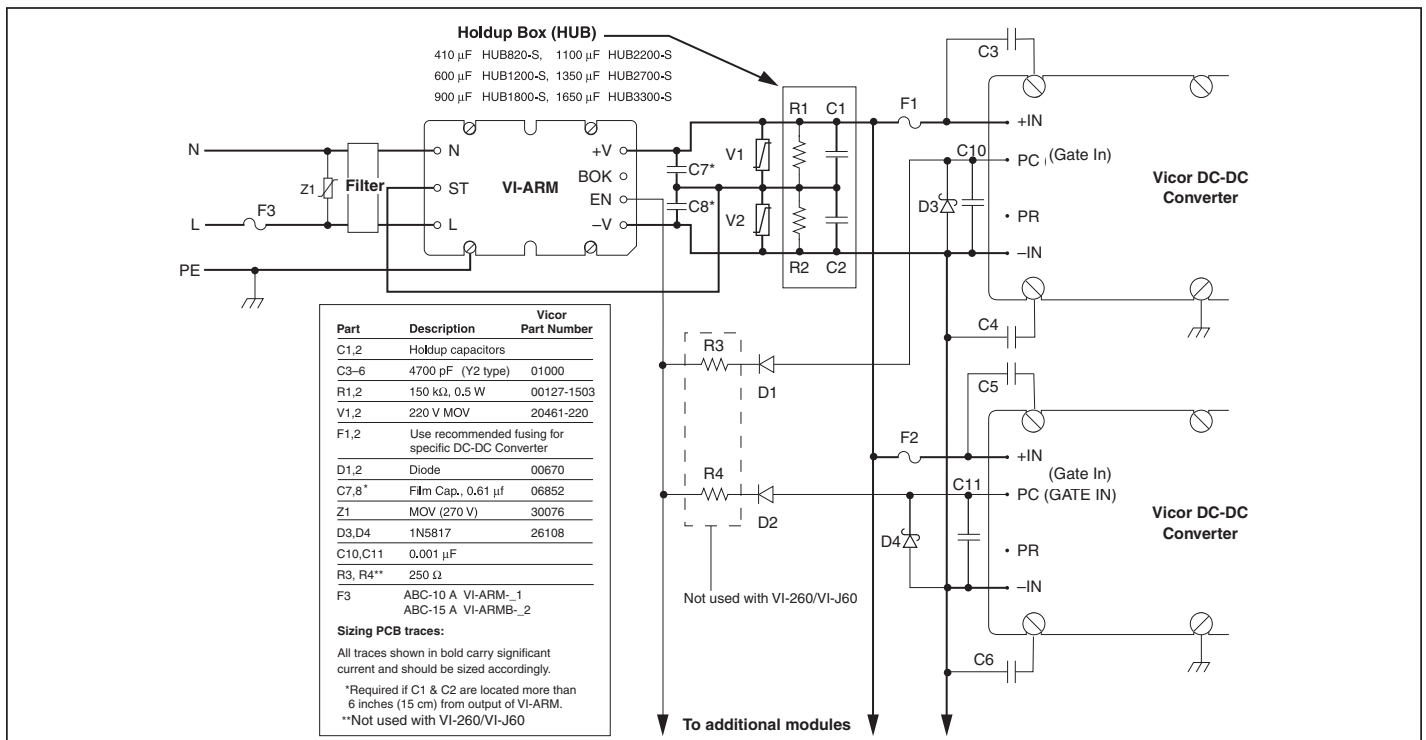

Figure 10 — Converter connections

APPLICATION NOTE (CONT.)

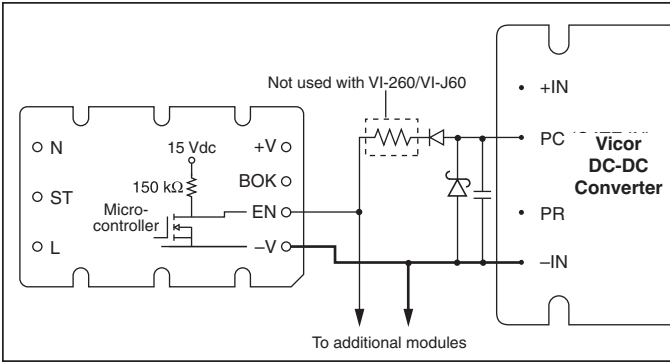

Figure 11 — Enable (EN) function; See Fig.8 for details

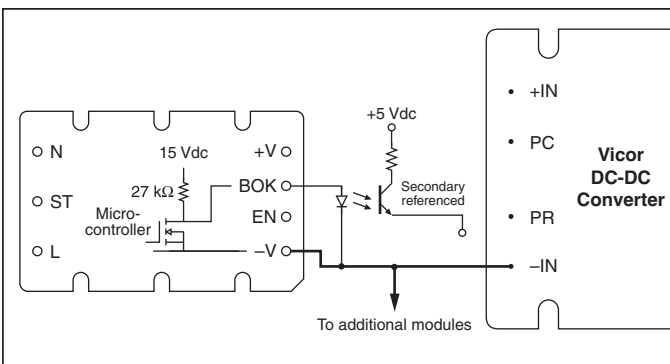

Figure 12 — Bus OK (B OK) isolated power status indicator

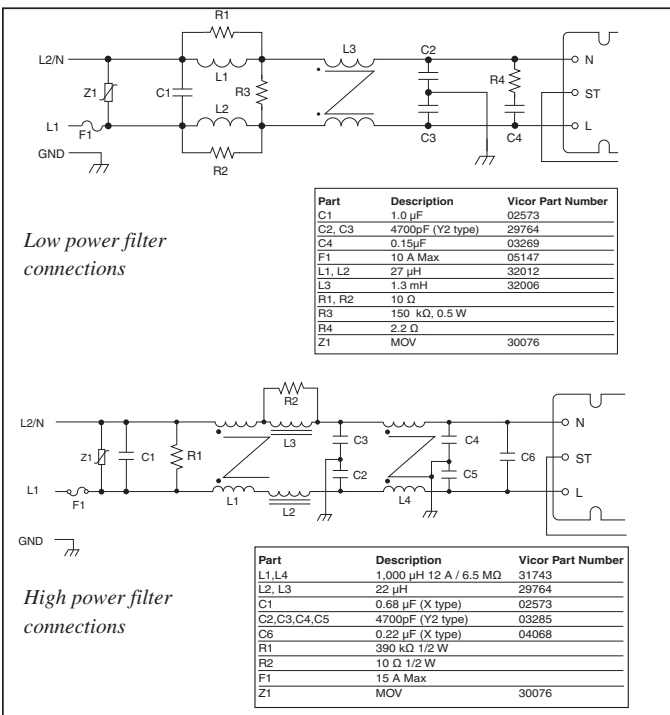

Figure 13 — Filter connections

Bus-OK (B OK) Pin. (See Fig. 12). The Bus-OK pin is intended to provide early-warning power fail information and is also referenced to the negative output pin.

Caution: There is no input-to-output isolation in the ARM. It is necessary to monitor Bus-OK via an optoisolator if it is to be used on the secondary (output) side of the converters. A line isolation transformer should be used when performing scope measurements. Scope probes should never be applied simultaneously to the input and output as this will destroy the module.

Filter. Two input filter recommendations are shown for low power VI-ARM-x1 and high power VI-ARMB-x2 (See Fig. 13). Both filter configurations provide sufficient common mode and differential mode insertion loss in the frequency range between 100 kHz and 30 MHz to comply with the Level B conducted emissions limit.

Hold-up Capacitors. Hold-up capacitor values should be determined according to output bus voltage ripple, power fail hold-up time, and ride-through time. (See Fig. 14). Many applications require the power supply to maintain output regulation during a momentary power failure of specified duration, i.e., the converters must hold-up or ride-through such an event while maintaining undisturbed output voltage regulation. Similarly, many of these same systems require notification of an impending power failure in order to allow time to perform an orderly shutdown.

The energy stored on a capacitor which has been charged to voltage V is:

$$\epsilon = 1/2(CV^2) \tag{1}$$

Where: ϵ = stored energy
 C = capacitance
 V = voltage across the capacitor

Energy is given up by the capacitors as they are discharged by the converters. The energy expended (the power-time product) is:

$$\epsilon = P\Delta t = C(V_1^2 - V_2^2) / 2 \tag{2}$$

Where: P = operating power
 Δt = discharge interval
 V_1 = capacitor voltage at the beginning of Δt
 V_2 = capacitor voltage at the end of Δt

Rearranging equation 2 to solve for the required capacitance:

$$C = 2P\Delta t / (V_1^2 - V_2^2) \tag{3}$$

APPLICATION NOTE (CONT.)

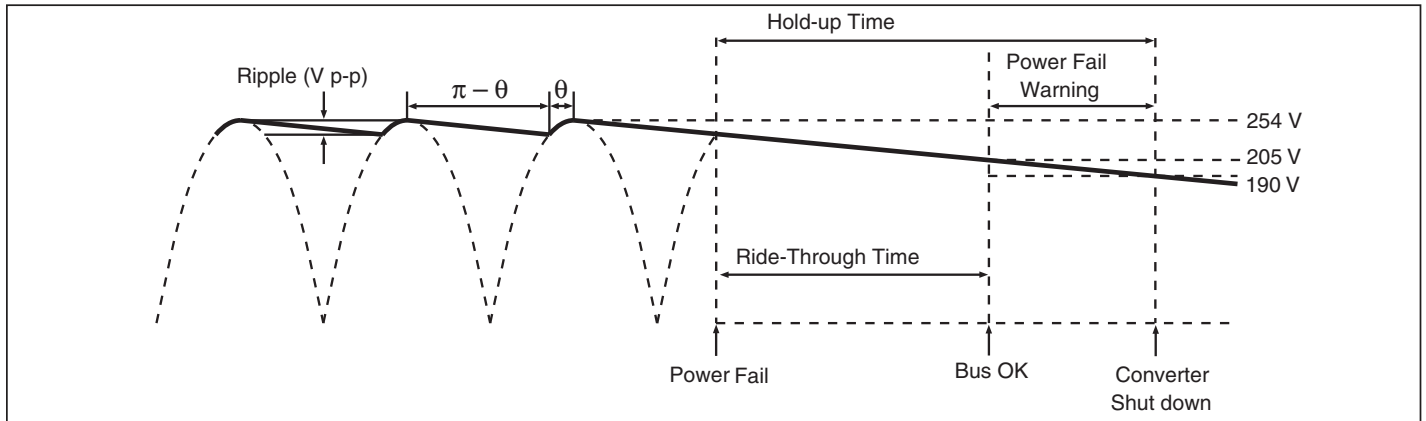

Figure 14 — Hold-up time

The power fail warning time (Δt) is defined as the interval between (B OK) and converter shutdown (EN) as illustrated in Fig. 12. The Bus-OK and Enable thresholds are 205 V and 190 V, respectively. A simplified relationship between power fail warning time, operating power, and bus capacitance is obtained by inserting these constants:

$$C = 2P\Delta t / (205^2 - 190^2)$$

$$C = 2P\Delta t / (5,925)$$

It should be noted that the series combination ($C1$, $C2$, Fig. 10) requires each capacitor to be twice the calculated value, but the required voltage rating is reduced to 200 V.

Allowable ripple voltage on the bus (or ripple current in the capacitors) may define the capacitance requirement. Consideration should be given to converter ripple rejection and resulting output ripple voltage.

For example, a converter whose output is 15 V and nominal input is 300 V will provide 56 dB ripple rejection, i.e., 10 V p-p of input ripple will produce 15 mV p-p of output ripple. (See Fig. 18) Equation 3 is again used to determine the required capacitance. In this case, V_1 and V_2 are the instantaneous values of bus voltage at the peaks and valleys (see Fig. 14) of the ripple, respectively. The capacitors must hold up the bus voltage for the time interval (Δt) between peaks of the rectified line as given by:

$$\Delta t = (\pi - \theta) / 2\pi f \quad (4)$$

Where: f = line frequency
 θ = rectifier conduction angle

The approximate conduction angle is given by:

$$\theta = \cos^{-1} V_2 / V_1 \quad (5)$$

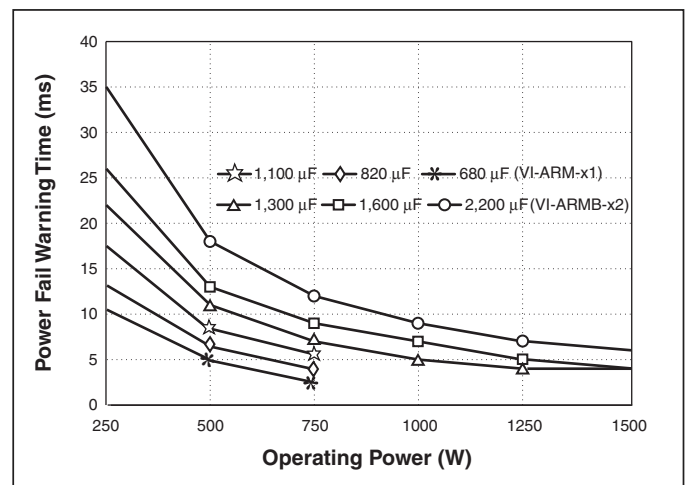

Figure 15 — Power fail warning time vs. operating power and total bus capacitance, series combination of $C1$, $C2$ (Fig. 10)

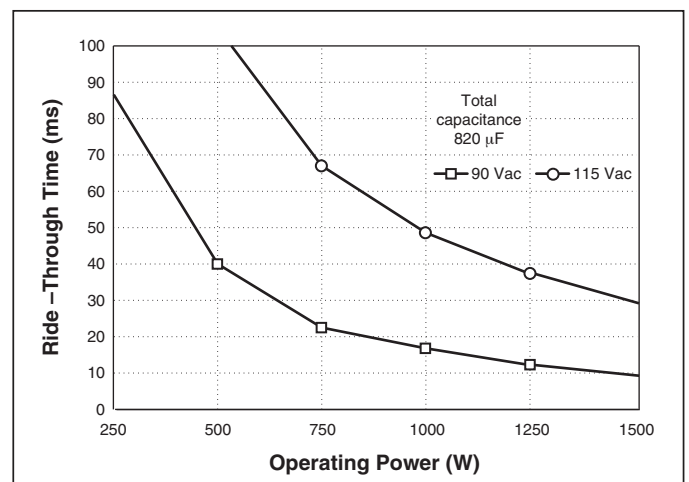

Figure 16 — Ride-through time vs. operating power

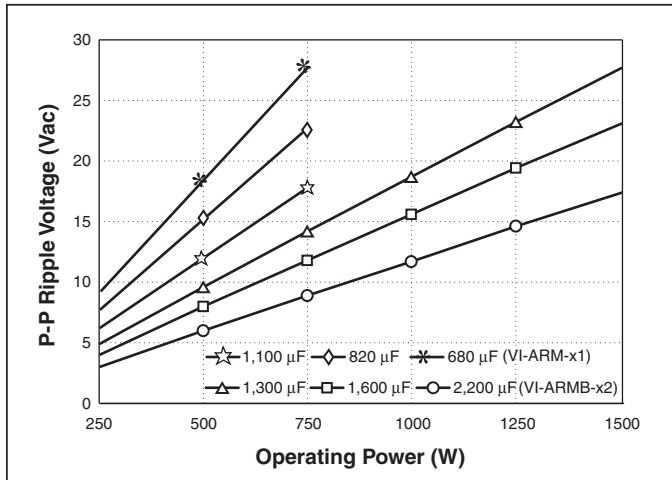

Figure 17 — Ripple voltage vs. operating power and bus capacitance, series combination of C1, C2 (see Fig. 10)

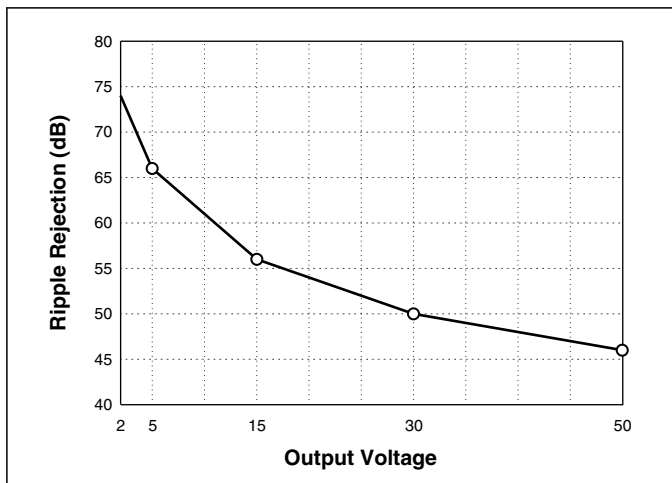

Figure 18 — Converter ripple rejection vs. output voltage (typical)

Another consideration in hold-up capacitor selection is their ripple current rating. The capacitors’ rating must be higher than the maximum operating ripple current. The approximate operating ripple current (rms) is given by:

$$I_{rms} = 2P/Vac \tag{6}$$

Where: P = operating power level
 Vac = operating line voltage

Calculated values of bus capacitance for various hold-up time, ride-through time, and ripple voltage requirements are given as a function of operating power level in Figures 15, 16, and 17, respectively.

Example

In this example, the output required at the point of load is 12 Vdc at 320 W. Therefore, the output power from the ARM would be 375 W (assuming a converter efficiency of 85%). The desired hold-up time is 9 ms over an input range of 90 to 264 Vac.

Determining Required Capacitance for Power Fail

Warning. Fig. 15 is used to determine hold-up capacitance for a given power fail warning time and power level, and shows that the total bus capacitance must be at least 820 μF. Since two capacitors are used in series, each capacitor must be at least 1,640 μF.

Note: The warning time is not dependent on line voltage. A hold-up capacitor calculator is available on the Vicor website, at vicorpower.com/hubcalc.

Determining Ride-through Time. Figure 16 illustrates ride-through time as a function of line voltage and output power, and shows that at a nominal line of 115 Vac, ride-through would be 68 ms. Ride-through time is a function of line voltage.

Determining Ripple Voltage on the Hold-up Capacitors.

Fig. 17 is used to determine ripple voltage as a function of operating power and bus capacitance, and shows that the ripple voltage across the hold-up capacitors will be 12 Vac.

Determining the Ripple on the Output of the

DC-DC Converter. Fig. 18 is used to determine the ripple rejection of the DC-DC converter and indicates a ripple rejection of approximately 60 dB for a 12 Volt output. If the ripple on the bus voltage is 12 Vac and the ripple rejection of the converter is 60 dB, the output ripple of the converter due to ripple on its input (primarily 120 Hz) will be 12 mV p-p. Note that Maxi, Mini, Micro converters have greater ripple rejection than either VI-200s or VI-J00s.

For more information about designing an autoranging AC input power supply using the ARM and Vicor DC-DC converter modules, contact Vicor Applications Engineering at the nearest Vicor Technical Support Center (see back cover), or send an E-mail to apps@vicorpower.com.

• • •

MECHANICAL DRAWINGS

Module Outline

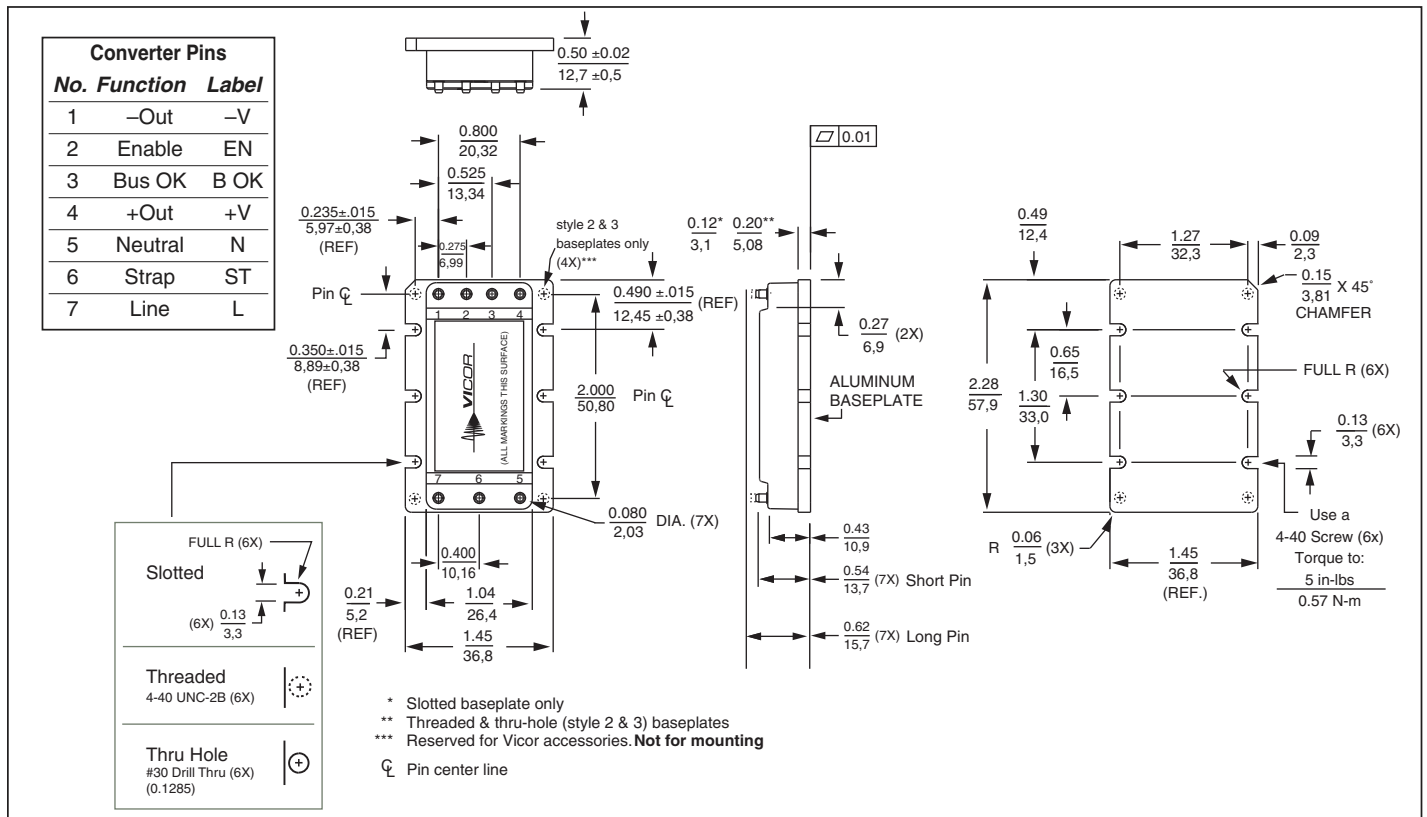

PCB Mounting Specifications

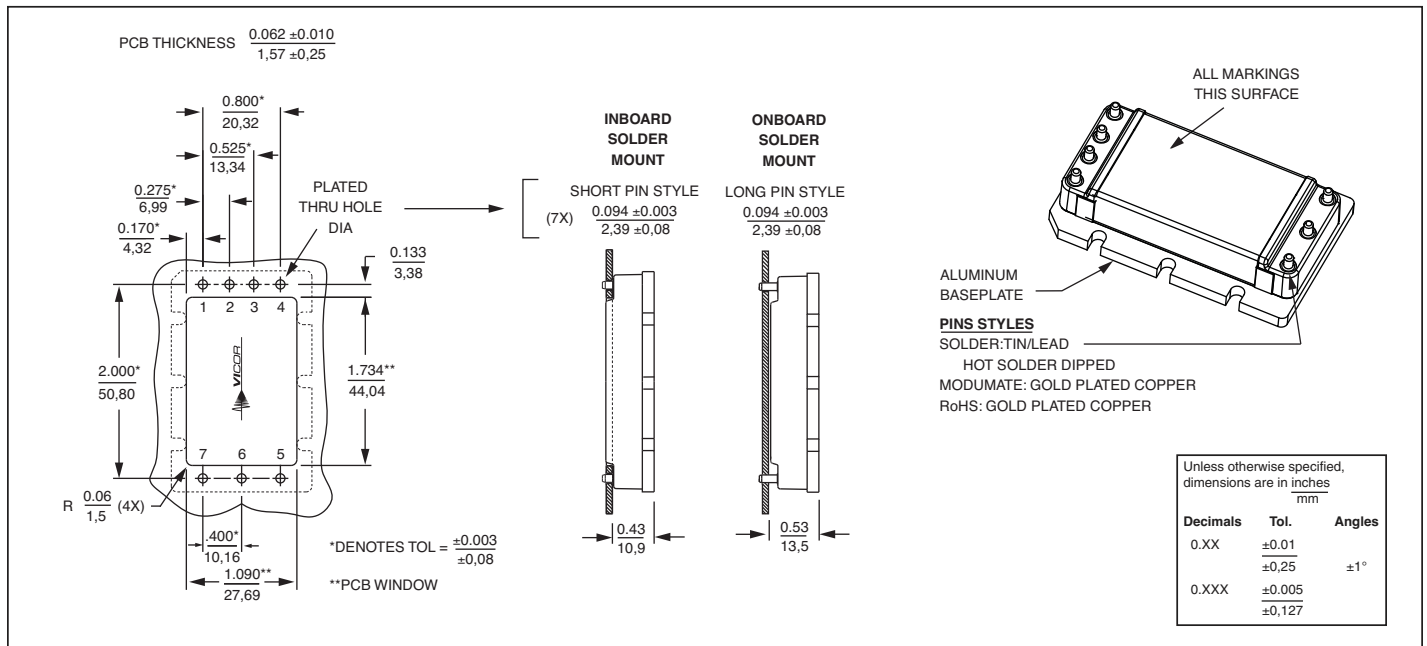

Warranty

Vicor products are guaranteed for two years from date of shipment against defects in material or workmanship when in normal use and service. This warranty does not extend to products subjected to misuse, accident, or improper application or maintenance. Vicor shall not be liable for collateral or consequential damage. This warranty is extended to the original purchaser only.

EXCEPT FOR THE FOREGOING EXPRESS WARRANTY, VICOR MAKES NO WARRANTY, EXPRESS OR IMPLIED, INCLUDING, BUT NOT LIMITED TO, THE WARRANTY OF MERCHANTABILITY OR FITNESS FOR A PARTICULAR PURPOSE.

Vicor will repair or replace defective products in accordance with its own best judgement. For service under this warranty, the buyer must contact Vicor to obtain a Return Material Authorization (RMA) number and shipping instructions. Products returned without prior authorization will be returned to the buyer. The buyer will pay all charges incurred in returning the product to the factory. Vicor will pay all reshipment charges if the product was defective within the terms of this warranty.

Information published by Vicor has been carefully checked and is believed to be accurate; however, no responsibility is assumed for inaccuracies. Vicor reserves the right to make changes to any products without further notice to improve reliability, function, or design. Vicor does not assume any liability arising out of the application or use of any product or circuit; neither does it convey any license under its patent rights nor the rights of others. Vicor general policy does not recommend the use of its components in life support applications wherein a failure or malfunction may directly threaten life or injury. Per Vicor Terms and Conditions of Sale, the user of Vicor components in life support applications assumes all risks of such use and indemnifies Vicor against all damages.

Vicor's comprehensive line of power solutions includes high density AC-DC and DC-DC modules and accessory components, fully configurable AC-DC and DC-DC power supplies, and complete custom power systems.

Information furnished by Vicor is believed to be accurate and reliable. However, no responsibility is assumed by Vicor for its use. Vicor components are not designed to be used in applications, such as life support systems, wherein a failure or malfunction could result in injury or death. All sales are subject to Vicor's Terms and Conditions of Sale, which are available upon request.

Specifications are subject to change without notice.

Intellectual Property Notice

Vicor and its subsidiaries own Intellectual Property (including issued U.S. and Foreign Patents and pending patent applications) relating to the products described in this data sheet. Interested parties should contact Vicor's Intellectual Property Department.

Vicor Corporation
25 Frontage Road
Andover, MA, USA 01810
Tel: 800-735-6200
Fax: 978-475-6715

email

Customer Service: custserv@vicorpower.com
Technical Support: apps@vicorpower.com