



# Numonyx™ Serial Flash Memory (S33)

*16-, 32-, and 64-Mbit*

---

**Datasheet**

## Product Features

- Architecture
  - SPI-compatible serial interface
  - Eight 8-Kbyte parameter blocks; configurable as one 64-Kbyte main memory sector
  - 64-Kbyte main memory sectors
    - 16 Mbit (31 sectors)
    - 32 Mbit (63 sectors)
    - 64 Mbit (127 sectors)
- Voltage and Power
  - $V_{cc} = 2.7\text{ V to }3.6\text{ V}$
  - Standby current: 15  $\mu\text{A}$  (Typ)
  - Read current: 3 mA (Typ) at 33.3 MHz; 6 mA (Typ) at 68 MHz
- Performance
  - 68-MHz fast read; 33.3 MHz standard read
  - 256-byte program buffer
- Software
  - Driver and file manager
- Security
  - One-Time Programmable Space
  - 64 unique factory device identifier bits
  - 64 user-programmable OTP bits
  - Additional 3920 user-programmable OTP bits
- Quality and Reliability
  - Operating temperature:  $-40\text{ }^{\circ}\text{C to }+85\text{ }^{\circ}\text{C}$
  - 100K minimum erase cycles per sector (block)
  - 0.13  $\mu\text{m}$  ETOX™ VIII process
- Density and Packaging
  - 16-, -32-, -64-Mbit densities in SOIC-16 package
  - 16-Mbit density in SOIC-8 package
  - Industry standard packaging and pinout

Order Number: 314822-03  
December 2007

INFORMATION IN THIS DOCUMENT IS PROVIDED IN CONNECTION WITH NUMONYX™ PRODUCTS. NO LICENSE, EXPRESS OR IMPLIED, BY ESTOPPEL OR OTHERWISE, TO ANY INTELLECTUAL PROPERTY RIGHTS IS GRANTED BY THIS DOCUMENT. EXCEPT AS PROVIDED IN NUMONYX'S TERMS AND CONDITIONS OF SALE FOR SUCH PRODUCTS, NUMONYX ASSUMES NO LIABILITY WHATSOEVER, AND NUMONYX DISCLAIMS ANY EXPRESS OR IMPLIED WARRANTY, RELATING TO SALE AND/OR USE OF NUMONYX PRODUCTS INCLUDING LIABILITY OR WARRANTIES RELATING TO FITNESS FOR A PARTICULAR PURPOSE, MERCHANTABILITY, OR INFRINGEMENT OF ANY PATENT, COPYRIGHT OR OTHER INTELLECTUAL PROPERTY RIGHT. Numonyx products are not intended for use in medical, life saving, life sustaining, critical control or safety systems, or in nuclear facility applications.

Numonyx B.V. may make changes to specifications and product descriptions at any time, without notice.

Numonyx B.V. may have patents or pending patent applications, trademarks, copyrights, or other intellectual property rights that relate to the presented subject matter. The furnishing of documents and other materials and information does not provide any license, express or implied, by estoppel or otherwise, to any such patents, trademarks, copyrights, or other intellectual property rights.

Designers must not rely on the absence or characteristics of any features or instructions marked "reserved" or "undefined." Numonyx reserves these for future definition and shall have no responsibility whatsoever for conflicts or incompatibilities arising from future changes to them.

Contact your local Numonyx sales office or your distributor to obtain the latest specifications and before placing your product order.

Copies of documents which have an order number and are referenced in this document, or other Numonyx literature may be obtained by visiting Numonyx's website at <http://www.numonyx.com>.

Numonyx, the Numonyx logo, and StrataFlash are trademarks or registered trademarks of Numonyx B.V. or its subsidiaries in other countries.

\*Other names and brands may be claimed as the property of others.

Copyright © 2007, Numonyx B.V., All Rights Reserved.

# Contents

---

<b>1.0</b>	<b>Introduction</b> .....	6
1.1	Nomenclature .....	6
1.2	Acronyms.....	6
1.3	Conventions .....	6
<b>2.0</b>	<b>Functional Overview</b> .....	8
2.1	Memory Maps .....	8
<b>3.0</b>	<b>Package Information</b> .....	10
3.1	SOIC-8 Package.....	10
3.2	SOIC-16 Package .....	11
<b>4.0</b>	<b>Pinouts and Signal Descriptions</b> .....	12
4.1	SOIC-8 Pinout (16-Mbit).....	12
4.2	SOIC-16 Package Pinout.....	12
4.3	Signal Descriptions.....	13
<b>5.0</b>	<b>Maximum Ratings and Operating Conditions</b> .....	14
5.1	Absolute Maximum Ratings.....	14
5.2	Operating Conditions .....	14
5.3	Power Supply.....	14
5.3.1	Power-Up/Down Characteristics.....	14
5.3.2	Power Supply Decoupling .....	15
<b>6.0</b>	<b>Electrical Characteristics</b> .....	16
6.1	DC Current Specifications .....	16
6.2	DC Voltage Specifications .....	16
6.3	Capacitance.....	17
<b>7.0</b>	<b>AC Characteristics</b> .....	18
7.1	AC Test Conditions .....	18
7.2	AC Timing Characteristics.....	19
7.2.1	Serial Input Characteristics.....	19
7.2.2	Write Protect Setup and Hold Timing.....	20
7.2.3	Output Timing.....	20
7.2.4	Hold Timing.....	21
7.2.5	Other Timings.....	22
<b>8.0</b>	<b>Device Operations</b> .....	23
8.1	SPI Bus Operations.....	23
8.1.1	SPI Modes .....	23
8.1.2	The Hold State .....	24
8.2	SPI Command Set.....	25
8.2.1	Write SPI SR Command (01h).....	26
8.2.2	Page Program Command (02h) .....	26
8.2.3	Read Data Bytes Command (03h).....	27
8.2.4	Write Disable Command (04h) .....	27
8.2.5	Read SPI SR Command (05h) .....	27
8.2.6	Write Enable Command (06h) .....	27
8.2.7	Fast Read Data Bytes Command (0Bh).....	28
8.2.8	Clear SR Fail Flags Command (30h) .....	28
8.2.9	Parameter Block Erase Command (40h) .....	28
8.2.10	OTP Program Command (42h) .....	29
8.2.11	Read OTP Data Bytes Command (4Bh) .....	29
8.2.12	Read ID Command (9Fh).....	29

8.2.13	Release from DPD Command (ABh) .....	29
8.2.14	Deep Power-Down Command (B9h) .....	29
8.2.15	Bulk Erase Command (C7h) .....	29
8.2.16	Sector Erase Command (D8h) .....	30
8.3	Status Register Definition .....	30
8.3.1	Main Memory Protection .....	31
8.4	SPI Instruction Cycle Examples.....	32
8.4.1	Fast Read .....	32
8.4.2	Page Program .....	33
8.4.3	Write Enable .....	34
<b>9.0</b>	<b>Security Features</b> .....	<b>36</b>
9.1	OTP Memory Space .....	36
9.1.1	Programming OTP Address Space .....	36
9.1.2	Reading OTP Data.....	36
9.1.3	Lock Protection Registers .....	36
<b>10.0</b>	<b>Numonyx™ Serial Flash Memory (S33) ID Codes</b> .....	<b>38</b>
<b>A</b>	<b>Write State Machine (WSM)</b> .....	<b>39</b>
<b>B</b>	<b>Ordering Information</b> .....	<b>41</b>

## Revision History

---

Date	Revision	Description
August 2006	001	Initial release
January 2007	002	Revised SOIC-8 Pinout, 16-Mbit ( <a href="#">Figure 3, "SOIC-8 Pinout (16-Mbit)"</a> on page 12) in <a href="#">Section 4.0, "Pinouts and Signal Descriptions"</a> on page 12.
November 2007	03	Applied Numonyx template.

## 1.0 Introduction

This document describes the Numonyx™ Serial Flash Memory (S33) device features, operation, and specifications.

The S33 device provides superior performance with enhanced security features, taking advantage of the high quality and reliability of the NOR-based Intel 0.13  $\mu\text{m}$  ETOX\* VIII process technology. Offered in 16-Mbit, 32-Mbit, and 64-Mbit densities, the S33 device is hardware and software compatible with existing industry offerings to ensure ease of design.

The S33 device takes advantage of more than one billion units of flash manufacturing experience and is ideal for code and data applications where simplified interface and low cost are the primary requirements. Examples include PCs and notebooks, WLAN and DSL cards and routers, printers, TVs, DVD/CD players and recorders, and other consumer electronic devices.

## 1.1 Nomenclature

Block:	A group of flash cells that share common erase circuitry and erase simultaneously. For Serial Flash devices, Blocks are more commonly referred to as Sectors.
Cleared:	Indicates a logic zero (0).
Page:	A 256-byte main memory segment that is aligned to a 256-byte boundary.
Parameter Block:	An 8-KB memory segment that can be erased independently.
Program:	A data write operation to the flash array.
Sector:	A single 64-KB main block, or all eight of the 8-KB parameter blocks combined.
Set:	Indicates a logic one (1).

## 1.2 Acronyms

LSB:	Least Significant Bit
MSB:	Most Significant Bit
OTP:	One-Time Programmable
PR:	Protection Register
PRD:	Protection Register Data
RFU:	Reserved for Future Use
SR:	Status Register
WEL:	Write Enable Latch
WSM:	Write State Machine

## 1.3 Conventions

0x:	Hexadecimal prefix
0b:	Binary prefix
K:	1,000
M:	1,000,000
Nibble:	4 bits

### **Numonyx™ Serial Flash Memory (S33)**

Byte:	8 bits
Word:	16 bits
Kword:	1,024 words
Kb:	1,024 bits
KB:	1,024 bytes
Mb:	1,048,576 bits
MB:	1,048,576 bytes
Brackets:	Square brackets ([ ]) will be used to designate group membership or to define a group of signals with similar function (i.e. A[21:1], SR[4,1] and D[15:0]).
00FFh:	Denotes 16-bit hexadecimal numbers
00FF 00FFh:	Denotes 32-bit hexadecimal numbers

## 2.0 Functional Overview

This section provides an overview of the features and capabilities of the NAME OF PRODUCT.

The S33 device is available in 16-, 32-, and 64-Mbit densities with a common SPI interface. The SPI interface consists of 8 pins. Six of these pins are signals; the other two are Vcc and ground.

The S33 device contains eight 8-Kbyte parameter blocks and up to 127 64-Kbyte main memory sectors. The eight 8-Kbyte parameter blocks can be treated as one 64-Kbyte main memory sector.

The S33 device includes new security features. Two 8-byte, thirty 16-byte, and one 10-byte individually-lockable OTP Protection Registers can support multiple uses, including unique flash device identification.

A sector erase operation erases one of the device's 64-Kbyte main memory sectors or all eight 8-Kbyte parameter blocks in parallel, independent of other memory sectors. A parameter block erase operation erases the specified parameter block; the operation is ignored when the address is outside the parameter block space. Each block or memory sector can be independently erased 100,000 times. A bulk erase operation erases the entire chip.

Each device incorporates a write buffer of 256 bytes (128 words) to allow optimum programming performance. Page program operation uses the write buffer to program up to 256-bytes within a 256-byte-aligned main memory region. A given page can be programmed multiple times between erase cycles.

## 2.1 Memory Maps

**Table 1: Bottom Boot Memory Map (Sheet 1 of 2)**

Size (KB)	Sector	Memory Addressing (Hex)		
		64-Mbit	32-Mbit	16-Mbit
64	127	7F0000 - 7FFFFFFF		
64	126	7E0000 - 7EFFFF		
...	...	...		
64	64	400000 - 40FFFF		
64	63	3F0000 - 3FFFFFFF	3F0000 - 3FFFFFFF	
64	62	3E0000 - 3EFFFF	3E0000 - 3EFFFF	
...	...	...	...	
64	32	200000 - 20FFFF	200000 - 20FFFF	
64	31	1F0000 - 1FFFFFFF	1F0000 - 1FFFFFFF	1F0000 - 1FFFFFFF
64	30	1E0000 - 1EFFFF	1E0000 - 1EFFFF	1E0000 - 1EFFFF
...	...	...	...	...
64	16	100000 - 10FFFF	100000 - 10FFFF	100000 - 10FFFF
64	15	F0000 - FFFFFF	F0000 - FFFFFF	F0000 - FFFFFF
64	14	E0000 - EFFFFF	E0000 - EFFFFF	E0000 - EFFFFF
...	...	...	...	...
64	4	40000 - 4FFFFF	40000 - 4FFFFF	40000 - 4FFFFF



**Table 1: Bottom Boot Memory Map (Sheet 2 of 2)**

64	3	30000 - 3FFFF	30000 - 3FFFF	30000 - 3FFFF
64	2	20000 - 2FFFF	20000 - 2FFFF	20000 - 2FFFF
64	1	10000 - 1FFFF	10000 - 1FFFF	10000 - 1FFFF
8	0-H	E000 - FFFF	E000 - FFFF	E000 - FFFF
8	0-G	C000 - DFFF	C000 - DFFF	C000 - DFFF
8	0-F	A000 - BFFF	A000 - BFFF	A000 - BFFF
8	0-E	8000 - 9FFF	8000 - 9FFF	8000 - 9FFF
8	0-D	6000 - 7FFF	6000 - 7FFF	6000 - 7FFF
8	0-C	4000 - 5FFF	4000 - 5FFF	4000 - 5FFF
8	0-B	2000 - 3FFF	2000 - 3FFF	2000 - 3FFF
8	0-A	0 - 1FFF	0 - 1FFF	0 - 1FFF

### 3.0 Package Information

#### 3.1 SOIC-8 Package

Figure 1: SOIC-8 Package Drawing and Specifications

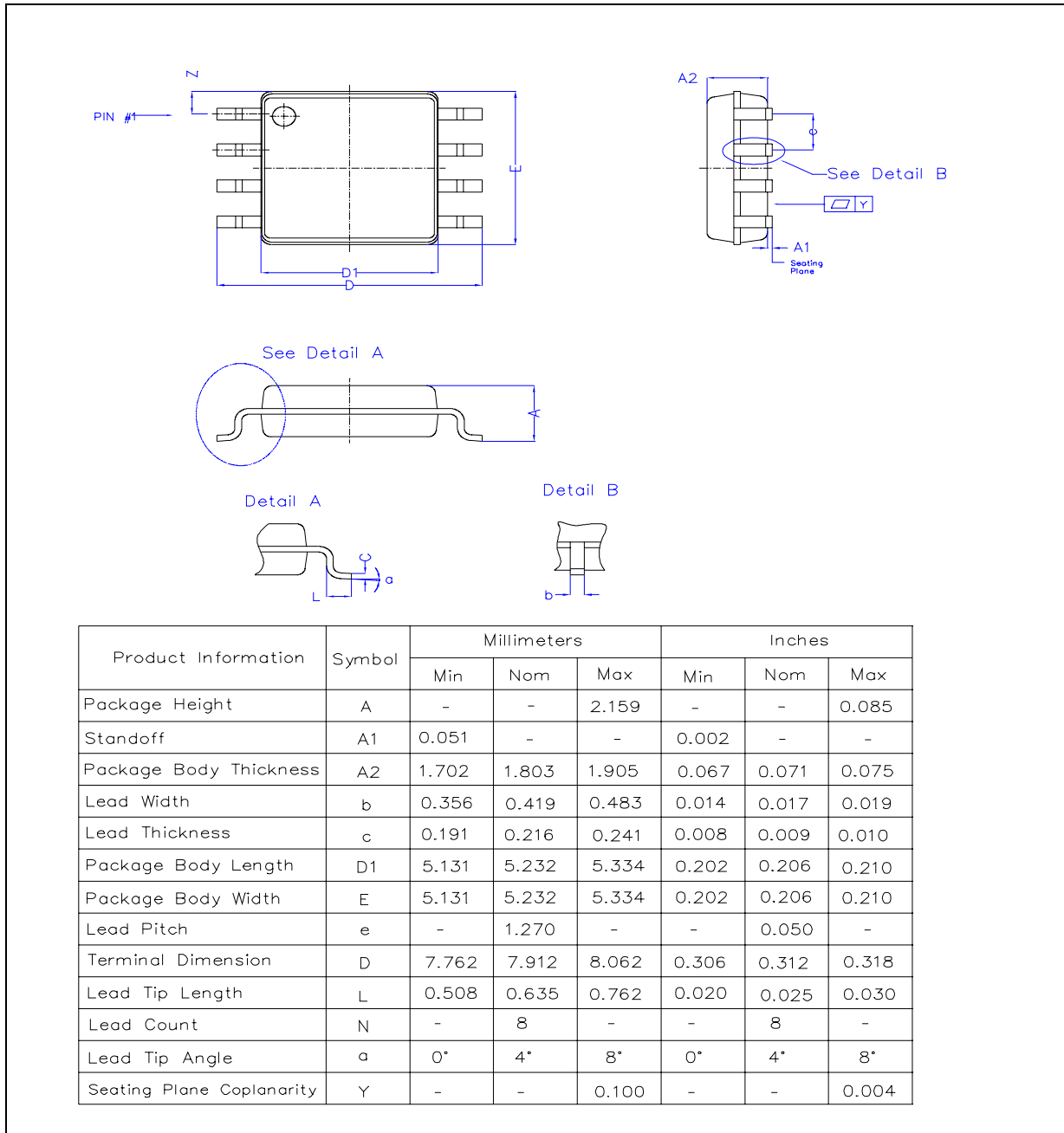

### 3.2 SOIC-16 Package

Figure 2: SOIC-16 Package Drawing and Specifications

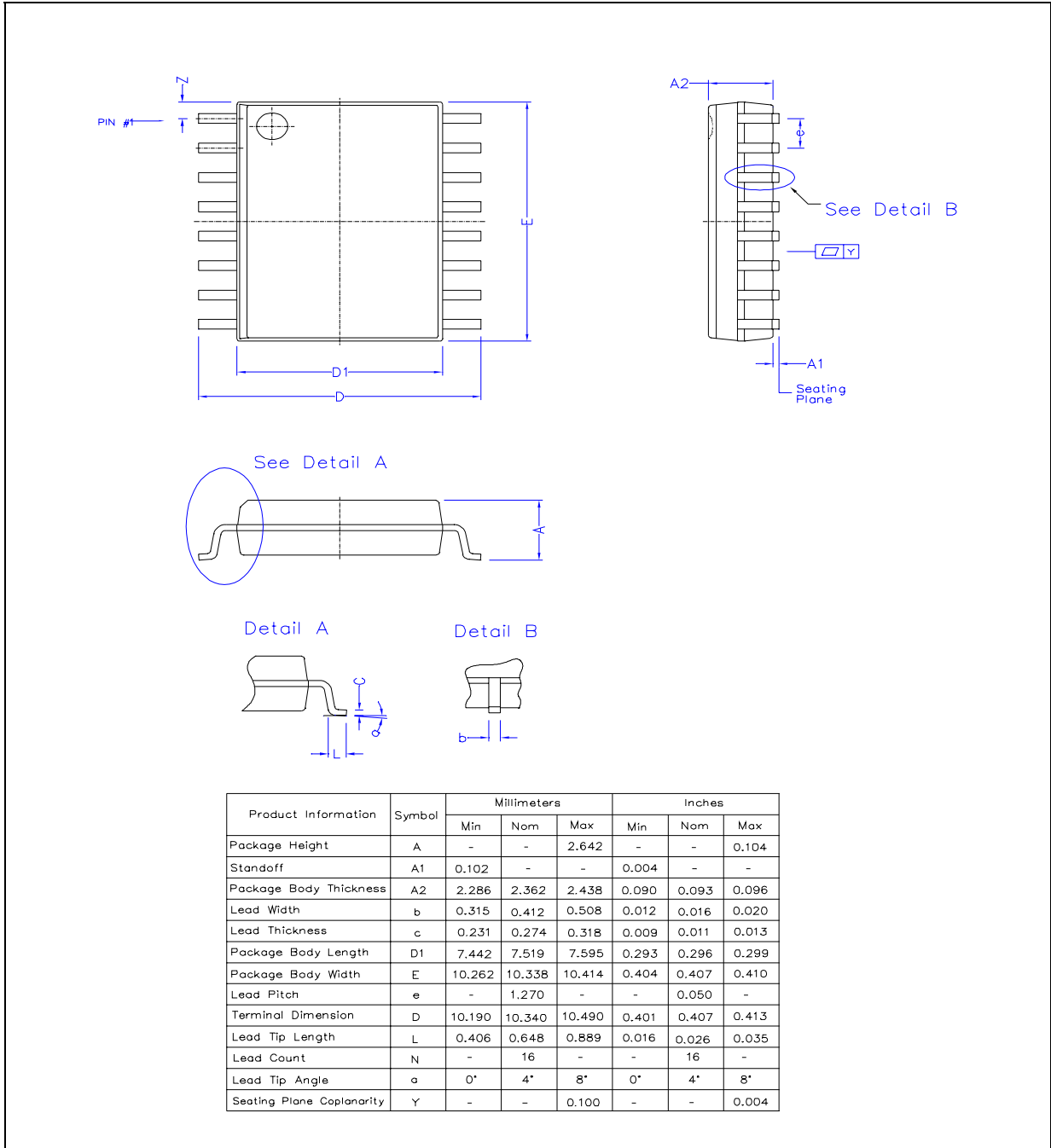

## 4.0 Pinouts and Signal Descriptions

The Numonyx™ Serial Flash Memory (S33) device is available in two package types. The 16-Mbit density is supported with SOIC-8 and SOIC-16 packages as shown in [Figure 3](#) and [Figure 4](#). The 32- and 64-Mbit densities are supported by the SOIC-16 package as shown in [Figure 4](#).

### 4.1 SOIC-8 Pinout (16-Mbit)

Figure 3: SOIC-8 Pinout (16-Mbit)

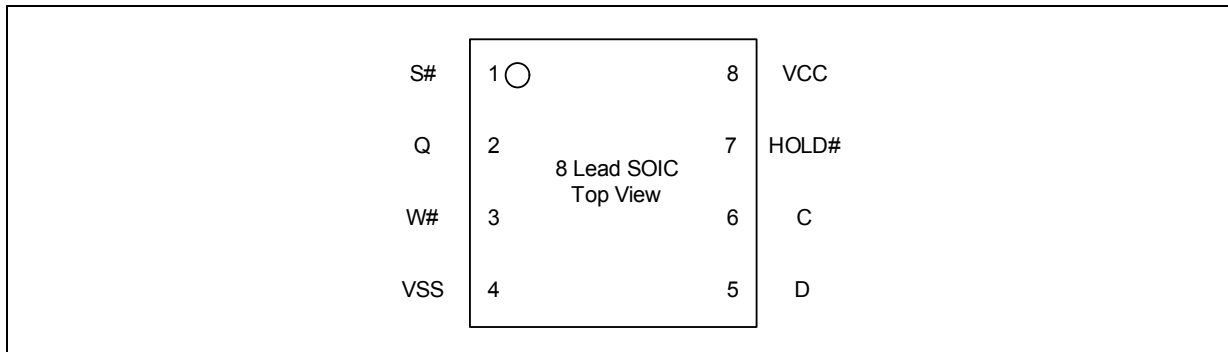

### 4.2 SOIC-16 Package Pinout

Figure 4: SOIC-16 Package Pinout



## 4.3 Signal Descriptions

**Table 2: Signal Descriptions**

Symbol	Type	Name and Function
C	Input	<b>SPI Clock:</b> Provides the timing of the SPI interface. OP codes, addresses, and data are latched in on the rising edge. SPI output data transitions after the falling edge.
D	Input	<b>SPI Data Input:</b> Shifts all data (including OP codes, Address Bytes, as well as Data Bytes) into the device. All data is clocked in on the rising edge of "C", starting with the MSB. The rising edge input applies to Modes 0 & 3 as depicted in <a href="#">Figure 12, "Supported SPI Bus Operation Modes" on page 24</a> .
Q	Output	<b>SPI Data Output:</b> Shifts all data out of the device. All output data is clocked out after the falling edge of "C", starting with the MSB. The falling edge output applies to Modes 0 & 3 as depicted in <a href="#">Figure 12, "Supported SPI Bus Operation Modes" on page 24</a> .
S#	Input	<b>SPI Select:</b> Falling S# edge triggers command writes to the SPI interface. Rising S# edge completes (or terminates) the SPI command cycle. When S# is high, "Q" is at high-Z.
HOLD#	Input	<b>SPI HOLD:</b> Internally freezes the Synchronization Clock and sets "Q" to high-Z. To enter the Hold condition, S# must be low. Refer to <a href="#">Section 8.1.2, "The Hold State" on page 24</a> for details.
W#	Input	<b>Write Protect:</b> Enables write protection. Refer to <a href="#">Table 18 on page 32</a> for details.
VCC	Power	<b>Power Supply:</b> Source voltage. Writes to the flash array are inhibited when $V_{CC} \leq V_{LKO}$ . Operations at invalid $V_{CC}$ should not be attempted.
VSS	Power	<b>Ground:</b> Connect to system ground. Do not float VSS.

## 5.0 Maximum Ratings and Operating Conditions

### 5.1 Absolute Maximum Ratings

**Warning:** Stressing the device beyond the “Absolute Maximum Ratings” may cause permanent damage. These are stress ratings only.

**Note:** This document contains information available at the time of its release. The specifications are subject to change without notice. Verify with your local Numonyx sales office that you have the latest datasheet before finalizing a design.

**Table 3: Absolute Maximum Ratings**

Parameter	Min	Max	Unit	Notes
Temperature under Bias Expanded ( $T_A$ , Ambient)	-40	+85	°C	4
Storage Temperature	-65	+125	°C	—
$V_{CC}$ Voltage	-2.0	+5.6	V	1, 2
$I_{SH}$ Output Short Circuit Current	—	100	mA	3

**Notes:**

1. Voltage is referenced to  $V_{SS}$ . During infrequent non-periodic transitions, the voltage potential between  $V_{SS}$  and input/output pins may undershoot to -2.0 V for periods < 20 ns or overshoot to  $V_{CCQ}(\text{max}) + 2.0$  V for periods < 20 ns.
2. During infrequent non-periodic transitions, the voltage potential between  $V_{CC}$  and the supplies may undershoot to -2.0 V for periods < 20 ns or  $V_{SUPPLY}(\text{max}) + 2.0$  V for periods < 20 ns.
3. Output is shorted for no more than one second. No more than one output shorted at a time.
4. Temperature specified is at ambient ( $T_A$ ) and not the package ( $T_C$ ).

### 5.2 Operating Conditions

**Warning:** Operation beyond the “Operating Conditions” is not recommended. Extended exposure beyond the “Operating Conditions” may affect device reliability.

**Table 5: Temperature and VCC Operating Condition**

Symbol	Parameter	Min	Nom	Max	Unit	Notes
$T_C$	Operating Temperature (case)	-40	+25	+85	°C	1
$V_{CC}$	$V_{CC}$ Supply Voltage	2.7	3.0	3.6	V	

**Note:**

1. Temperature specified is at case ( $T_C$ ) and/or ambient ( $T_A$ ).

### 5.3 Power Supply

This section provides an overview of system-level considerations with regards to the flash device. It includes a brief description of power-up, power-down and decoupling design considerations.

#### 5.3.1 Power-Up/Down Characteristics

The device is protected against accidental block erasure or programming during power transitions. After power-up, a  $t_{VSL}$  latency is required before S# can be brought low to issue a command.

### **5.3.2 Power Supply Decoupling**

Flash memory devices require careful power supply decoupling. The basic power supply considerations are as follows:

1. Standby current levels
2. Active current levels
3. Transient peaks produced when the device is enabled

When the device is accessed, many internal conditions change. Circuits within the device enable charge-pumps, and internal logic states change at high speed. All of these internal activities produce transient signals. Transient current magnitudes depend on the capacitive and inductive loading at the device output. Two-line control and correct de-coupling capacitor selection suppress transient voltage peaks.

Additionally, for every eight devices used in the system, a 4.7  $\mu\text{F}$  electrolytic capacitor should be placed between power and ground close to the devices. The bulk capacitor is meant to overcome voltage droop caused by PCB trace inductance.

## 6.0 Electrical Characteristics

### 6.1 DC Current Specifications

**Table 6: DC Current Characteristics**

Symbol	Parameter	Typ	Max	Unit	Test Conditions	Notes
$I_{LI}$	Input Load Current	—	±2	μA	$V_{CC} = V_{CC} \text{ Max}; V_{IN} = V_{CC} \text{ or } V_{SS}$	3
$I_{LO}$	Output Leakage Current	—	±2	μA	$V_{CC} = V_{CC} \text{ Max}; V_{IN} = V_{CC} \text{ or } V_{SS}$	—
$I_{CCS}$	$V_{CC}$ Standby Current	15	70	μA	$S\# = V_{CC}; V_{IN} = V_{CC} \text{ or } V_{SS}$	4,6
$I_{DPD}$	$V_{CC}$ Deep Power-Down Current	15	70	μA	$S\# = V_{CC}; V_{IN} = V_{CC} \text{ or } V_{SS}$	4
$I_{CCR}$	$V_{CC}$ Read Current	2	4	mA	20 MHz; No Load	—
		3	5		33.3 MHz; No Load	7
		5	8		50 MHz; No Load	
		6	10		68 MHz; No Load	
$I_{CCP}$	Page Program Current	18	25	mA	$S\# = V_{CC}; 256\text{-Byte Page}$	2,5
$I_{CCE}$	Parameter Block Erase Current	16	45	mA	$S\# = V_{CC}$	2,5
	Sector Erase Current	16	45	mA	$S\# = V_{CC}$	2,5
$I_{CCB}$	Bulk Erase Current	16	45	mA	$S\# = V_{CC}$	2,5

**Notes:**

- All currents are RMS unless noted. Typical values at typical  $V_{CC}$ ,  $T_C = +25\text{ }^\circ\text{C}$ .
- Sampled, not 100% tested.
- If  $V_{IN} > V_{CC}$  the input load current increases to 10 μA max.
- $I_{CCS}$  and  $I_{DPD}$  is the average current measured over any 5 ms time interval 5 μs after a S# de-assertion.
- $I_{CCP}$ ,  $I_{CCE}$  measured over typical or max times.
- $I_{CCS}$  will increase substantially if W# or HOLD# is toggled while in standby mode.
- $I_{CCR}$  will increase if D is toggled during read.

### 6.2 DC Voltage Specifications

**Table 7: DC Voltage Characteristics**

Symbol	Parameter	Min	Max	Unit	Test Conditions	Notes
$V_{IL}$	Input Low Voltage	0	$0.3 * V_{CC}$	V	—	1
$V_{IH}$	Input High Voltage	$0.7 * V_{CC}$	$V_{CC}$	V	—	1
$V_{OL}$	Output Low Voltage	—	0.1	V	$V_{CC} = V_{CCMin}$ $I_{OL} = 100\text{ } \mu\text{A}$	
$V_{OH}$	Output High Voltage	$V_{CC} - 0.1$	—	V	$V_{CC} = V_{CCMin}$ $I_{OH} = -100\text{ } \mu\text{A}$	—
$V_{LKO}$	$V_{CC}$ Lockout Voltage	2.0	—	V	—	—

**Note:**

- $V_{IL}$  can undershoot to  $-1.0\text{ V}$  for periods  $< 2\text{ ns}$  and  $V_{IH}$  may overshoot to a maximum of  $V_{CC} + 1.0\text{ V}$  for periods  $< 2\text{ ns}$ .



## 6.3 Capacitance

**Table 8: Device Capacitance**

Symbol	Parameter <sup>1</sup>	Type	Max	Unit	Condition <sup>2</sup>
C <sub>IN</sub>	Input Capacitance	6	8	pF	V <sub>IN</sub> = 0.0 V V <sub>CC</sub> = 0 V "or" V <sub>CC</sub> = V <sub>CCmax</sub>
C <sub>OUT</sub>	Output Capacitance	8	12	pF	V <sub>OUT</sub> = 0.0 V V <sub>CC</sub> = 0 V "or" V <sub>CC</sub> = V <sub>CCmax</sub>
<p><b>Notes:</b></p> <p>1. Sampled, not 100% tested.</p> <p>2. T<sub>A</sub> = +25 °C, f = 1 MHz.</p>					

## 7.0 AC Characteristics

### 7.1 AC Test Conditions

**Figure 5: Transient Equivalent Testing Load Circuit**

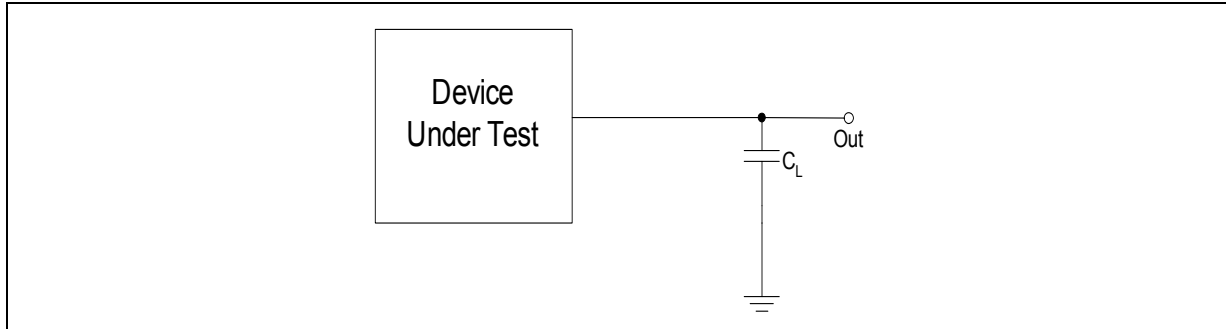

**Note:**  $C_L$  Includes Jig Capacitance

**Table 9: AC Measurement Conditions**

Parameter	Min	Max	Unit
Load Capacitance ( $C_L$ )	—	30 <sup>1</sup>	pF
Input Rise and Fall Times	0.3	3	ns
Input $V_{IL}$ Timing Reference Voltages	—	0.3* $V_{CC}$	V
Input $V_{IH}$ Timing Reference Voltages	0.7* $V_{CC}$	—	V
Input Drive Voltages	0 for $V_{IL}$ , $V_{CC}$ for $V_{IH}$		V
Input Timing Reference Voltages	0.3 $V_{CC}$ to 0.7 $V_{CC}$		V
Output Timing Reference Voltages	$V_{CC}/2$		V
<b>Note:</b>			
1. Output Hi-Z is defined as the point where data output is no longer driven.			

## 7.2 AC Timing Characteristics

### 7.2.1 Serial Input Characteristics

**Table 10: Serial Input Characteristics**

Sym	Parameter	Min	Max	Unit	Notes
$f_C$	Clock Frequency for all instructions except READ	D.C.	68.0	MHz	—
$f_R$	Clock Frequency for READ	D.C.	33.3	MHz	—
$t_{CH}$	Clock High Time	7	—	ns	1
$t_{CL}$	Clock Low Time	7	—	ns	1
$t_{CLCH}$	Clock Rise Time (peak to peak)	0.1	—	V/ns	2, 3,4
$t_{CHCL}$	Clock Fall Time (peak to peak)	0.1	—	V/ns	2, 3,4
$t_{CHSL}$	S# Active Setup Time (relative to preceding C edge)	5	—	ns	—
$t_{SLCH}$	S# Active Setup Time (relative to subsequent C edge)	5	—	ns	—
$t_{CHSH}$	S# Inactive Hold Time (relative to C)	5	—	ns	—
$t_{SHCH}$	S# Inactive Setup Time (relative to C)	5	—	ns	—
$t_{SHSL}$	S# Deselect Time	100	—	ns	—
$t_{DVCH}$	Data Input Setup Time	2	—	ns	—
$t_{CHDX}$	Data Input Hold Time	5	—	ns	—

**Notes:**

- $t_{CH} + t_{CL}$  must be greater than or equal to  $1/f_C(\text{max})$ .
- Sampled, not 100% tested.
- Expressed as a slew-rate.

† Minimum clock rise/fall times guarantee functionality. Clock rise/fall times must fall within the range specified in [Figure 9, "AC Measurement Conditions" on page 18](#) for compliance to timing specs.

**Figure 6: Serial Input Timing**

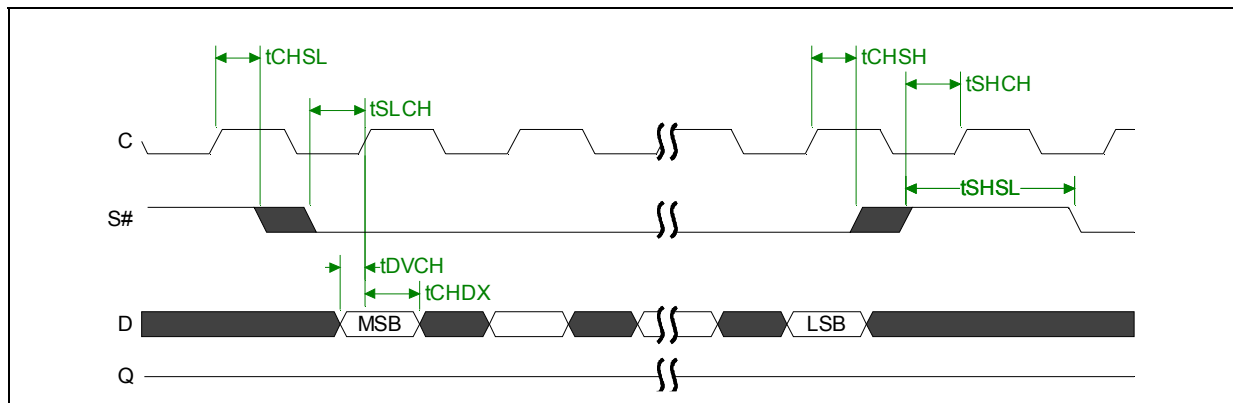

### 7.2.2 Write Protect Setup and Hold Timing

**Table 11: Write Protect Setup and Hold Timing**

Sym	Parameter	Min	Max	Unit	Notes
$t_{WHSL}$	W# Setup Time	20	—	ns	1
$t_{SHWL}$	W# Hold Time	100	—	ns	1

**Note:**  
1. Only applicable as a constraint for a WRSR instruction when SRWD is set to 1.

**Figure 7: Write Protect Setup and Hold Timing during WRSR when SRWD=1**

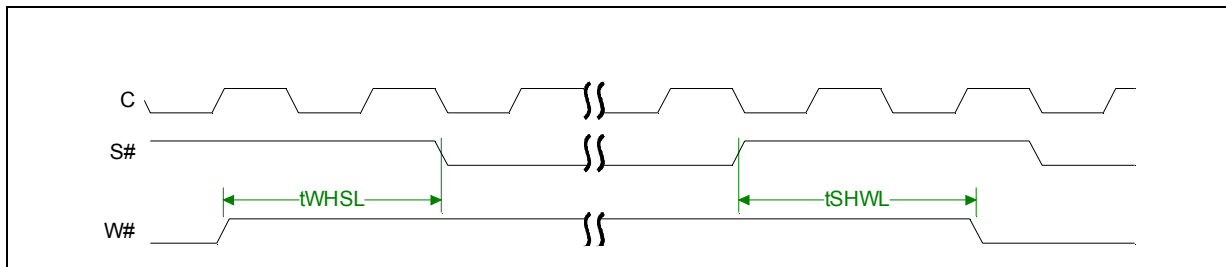

### 7.2.3 Output Timing

**Table 12: Output Timing**

Sym	Parameter	Min	Max	Unit	Notes
$t_{CLQV}$	Clock Low to Output Valid (30 pF, 2.7 V to 3.6 V)	—	8	ns	—
$t_{CLQV}$	Clock Low to Output Valid (10 pF, 3.0 V to 3.6 V)	—	6	ns	—
$t_{CLQX}$	Output Hold Time	0	—	ns	—
$t_{SHQZ}$	Output Disable Time	—	8	ns	1

**Note:**  
1. Sampled, not 100% tested.

**Figure 8: Output Timing**

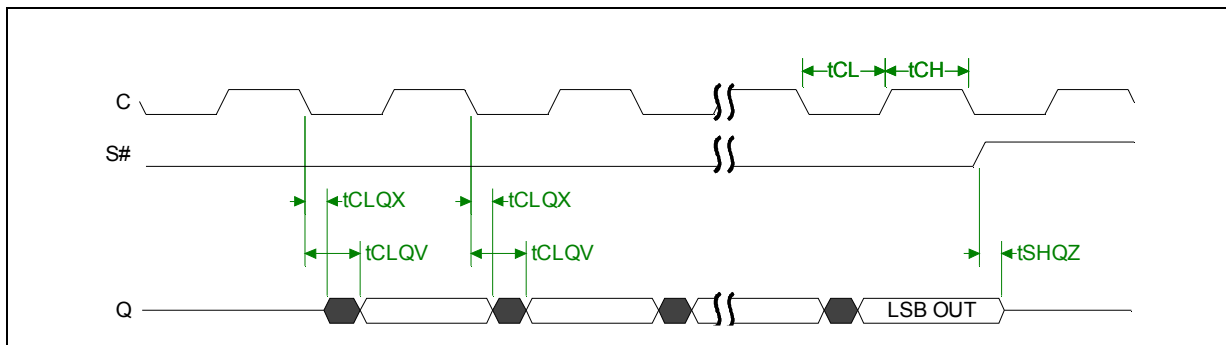

### 7.2.4 Hold Timing

**Table 13: Hold Timing**

Sym	Parameter	Min	Max	Unit	Notes
$t_{CHHL}$	HOLD# Assertion Hold Time (relative to C)	5	—	ns	—
$t_{HLCH}$	HOLD# Assertion Setup Time (relative to C)	5	—	ns	—
$t_{HLQZ}$	HOLD# Assertion to Output High-Z	—	8	ns	1
$t_{CHHH}$	HOLD# De-assertion Hold Time (relative to C)	5	—	ns	—
$t_{HHCH}$	HOLD# De-assertion Setup Time (relative to C)	5	—	ns	—
$t_{HHQX}$	HOLD# De-assertion to Output Low-Z	—	8	ns	1

**Note:**  
1. Sampled, not 100% tested.

**Figure 9: Hold Timing - Standard Usage**

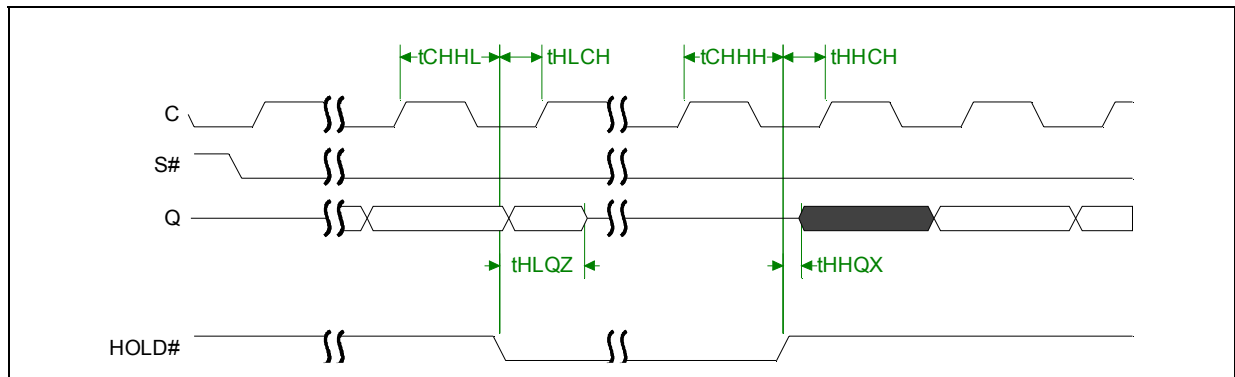

**Figure 10: Hold Timing - Non-standard Usage**

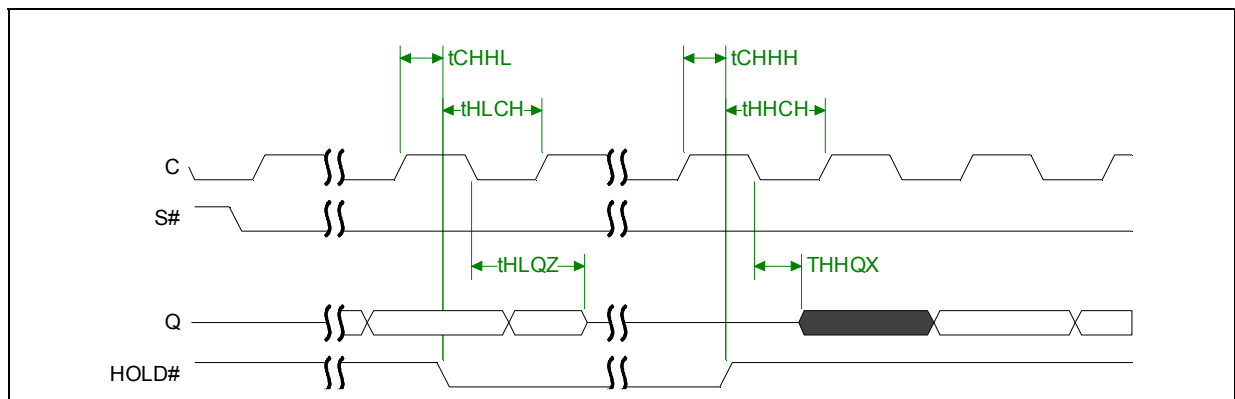

### 7.2.5 Other Timings

**Table 14: Other Timings**

Sym	Parameter	Min	Typ	Max	Unit	Notes
t <sub>PP</sub>	Page Program Time	—	1.4	10	ms	1
t <sub>BP</sub>	Byte OTP Program Time	—	40	175	μs	1
t <sub>SE</sub>	Parameter Block Erase Time (8 KB)	—	0.3	2.5	s	1
	Sector Erase Time (64 KB)	—	0.7	4.0	s	1
t <sub>BE</sub>	Bulk Erase Time (64 M)	—	89.6	512	s	1
	Bulk Erase Time (32 M)	—	44.8	256	s	1
	Bulk Erase Time (16 M)	—	22.4	128	s	1
t <sub>VSL</sub>	V <sub>CC</sub> power valid to S# assertion (low)	60	—	—	μs	—
t <sub>RDP</sub>	Release from DPD mode into standby mode	60	—	—	μs	—

**Figure 11: T<sub>VSL</sub> Power-up Timing**

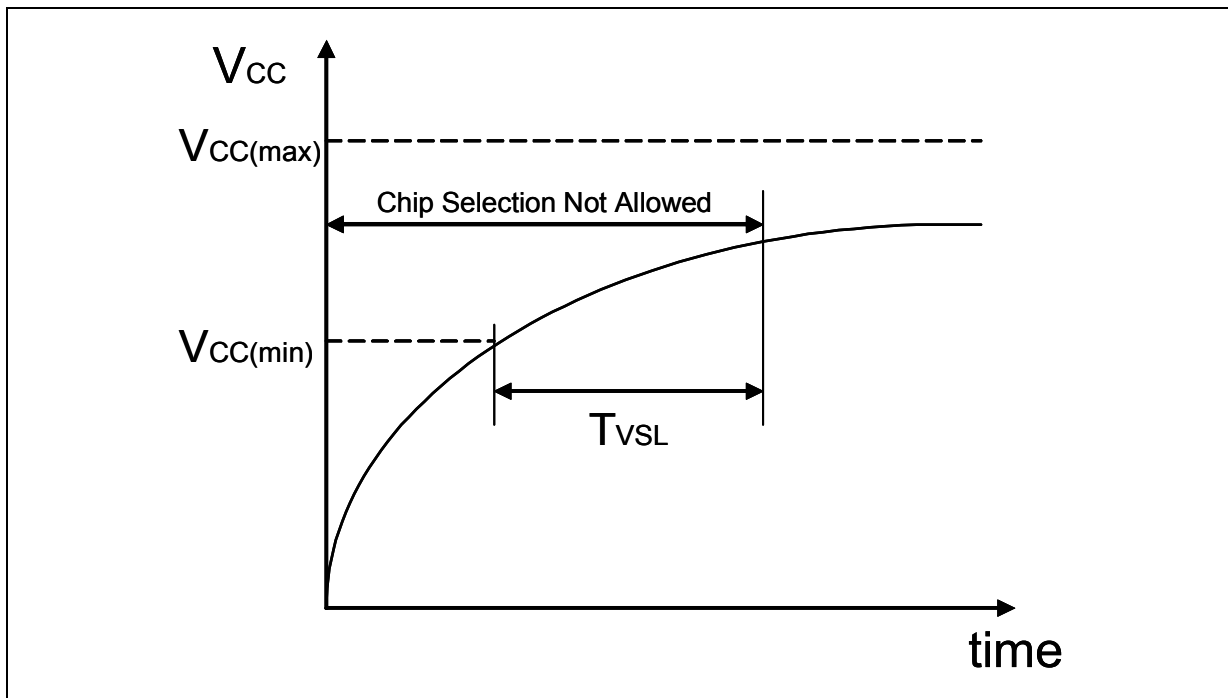

## 8.0 Device Operations

This section provides an overview of the Numonyx™ Serial Flash Memory (S33) device operations.

### 8.1 SPI Bus Operations

The SPI instruction cycle begins with a byte-wide OP Code that is initiated with the falling edge of S#. The 8-bit instruction is latched into "D" (data input), MSB first, on the rising edge of "C" (clock).

Some OP Codes are followed by an additional address and dummy and/or data bytes, MSB first. The number of input instruction bytes depends upon the OP Code. Refer to [Table 15, "SPI Command Set" on page 25](#) for the instruction protocols. Address and dummy bytes are input through "D" on the rising "C" edge.

Depending upon the OP Code, the data bytes are either *input* data through "D", or they are *output* data from "Q". On cycles that input data through "D", the output signal "Q" is at high-Z.

For instructions that change the memory contents or device configuration (such as a Status Register Write command), the rising S# edge must occur on a whole-byte increment, otherwise the command will be ignored.

For read operations, the instruction sequence can be botched (ignored) only if S# is raised before the input sequence is complete. After the required number of input bits is clocked into the device, a data stream is clocked out of "Q"; each bit is shifted out after the falling edge of "C" (MSB first). When data is streaming from "Q", raising S# will terminate the data stream and bring this output to high-Z.

The rising S# edge always resets the SPI command interpreter and places the output in high-Z. It also does one of the following actions:

- Terminates the output data stream (read operations)
- Kicks off program/erase algorithms
- Initiates changes to the SR
- Botches an SPI command when S# is raised too early (or too late for commands that alter the array or device configuration)
- Terminates a command and puts the device in standby mode (not in the case of a program or erase operation)

When S# is high and the internal algorithms are completed, the device will go into standby mode.

#### 8.1.1 SPI Modes

This device supports SPI bus operations Mode 0 and Mode 3, as depicted in [Figure 12, "Supported SPI Bus Operation Modes" on page 24](#). The difference between the two modes is the default state of the clock signal (C) when the SPI bus master is in standby. For Mode 0, the "C" is normally low; for Mode 3, "C" is normally high. For both modes, input data (D) is sampled on the rising edge of "C", and output data (Q) is updated on the falling edge of "C."

**Figure 12: Supported SPI Bus Operation Modes**

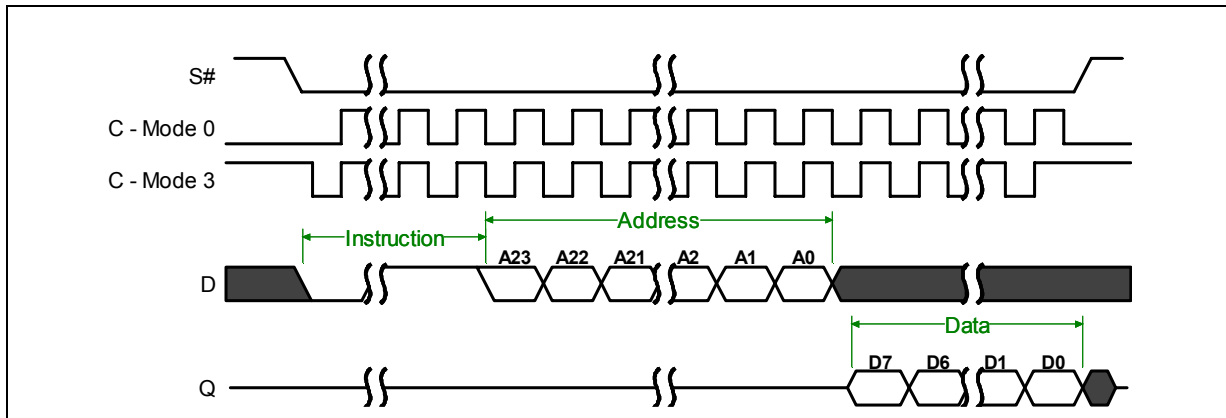

### 8.1.2 The Hold State

The HOLD# input signal freezes the internal Clock (C) without resetting the device's clocking sequence. However, taking HOLD# to  $V_{IL}$  does not terminate any program or erase operation that is currently in progress.

To enter the Hold State, the device must be selected ( $S\#$  at  $V_{IL}$ ). The Hold State starts on the falling edge of the HOLD# signal, provided that it coincides with the Clock at  $V_{IL}$  as shown in [Figure 13 on page 24](#). The Hold State ends on the rising edge of HOLD#, provided that it coincides with the SPI Clock at  $V_{IL}$ .

If the falling HOLD# edge does not coincide with the Clock at  $V_{IL}$ , the Hold State starts after the next falling edge of the Clock as shown in [Figure 14 on page 25](#). Similarly, if the rising edge does not coincide with the Clock at  $V_{IL}$ , the Hold State ends after the next falling edge of the Clock.

The command sequence will not necessarily abort if  $S\#$  is raised to  $V_{IH}$  while HOLD# is at  $V_{IL}$ . Raising  $S\#$  will complete the command sequence, regardless of the state of HOLD#. If a proper sequence was inputted prior to dropping HOLD# to  $V_{IL}$ , the input data stream will be recognized as a valid command sequence.

During the Hold State, the Data Output (Q) is at high impedance. The Clock Input and the Data Input (D) are Don't Care.

**Figure 13: Hold State – Standard Usage**

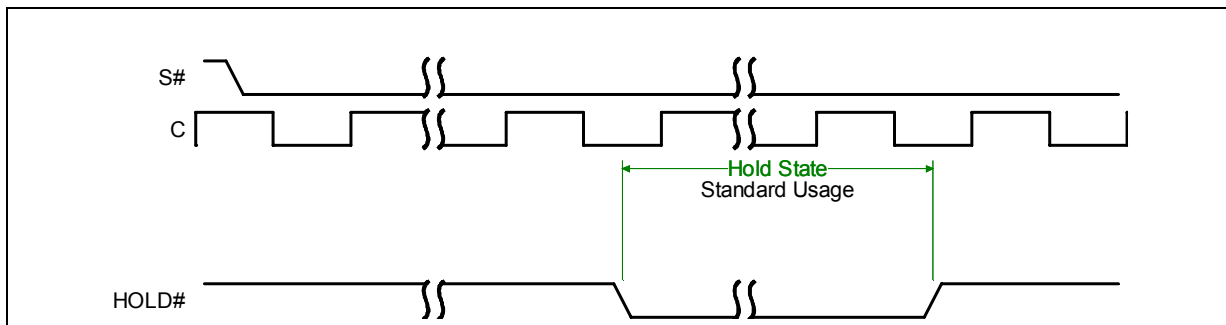
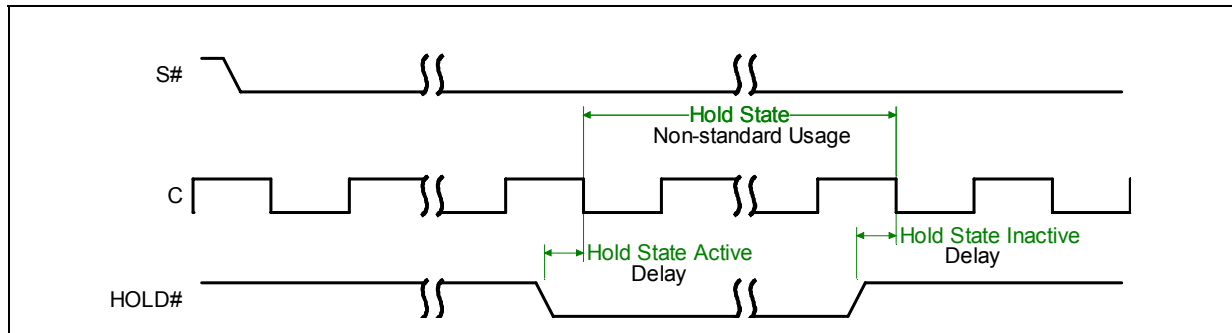



Figure 14: Hold State – Non-standard Usage



## 8.2 SPI Command Set

The SPI Command Set is found in Table 15. This table defines the commands (and the OP Codes) that are supported by the SPI interface. All other OP Codes will be ignored. All commands support frequencies up to 68 MHz except for the Read Data Bytes command (03h). The Read Data Bytes command (03h) supports up to 33.3 MHz.

Table 15: SPI Command Set (Sheet 1 of 2)

Instruction	Op Code	Addr Bytes	Dummy Bytes	Data Bytes	Name and Function
Write SPI SR	01h	-	-	1	Overwrites SR[7, 4:2] and (BP[2:0] SRWD). When W# = V <sub>IL</sub> & SRWD = 1, the values of BP[2:0] & SRWD cannot be changed.
Page Program	02h	3	-	1 to 256	Programs up to 256 bytes within a 256-byte-aligned main memory region.
Read Data Bytes	03h	3	-	1 to infinite	Supports up to 33.3 MHz Clock.
Write Disable	04h	-	-	-	Clears the WEL bit (SR1)
Read SR	05h	-	-	1 to infinite	Continuously Polls the SR
Write Enable	06h	-	-	-	Sets the WEL bit (SR1).
Fast Read Data Bytes	0Bh	3	1	1 to infinite	Supports up to a 68 MHz Clock; protocol uses a dummy byte.
Clear SR Fail Flags	30h	-	-	-	Resets the Erase Fail Flag and the Program Fail Flag (SR5 and SR6, respectively)
Parameter Block Erase	40h	3	-	-	Erases the specified parameter block; it is ignored when the address is outside parameter block space.
OTP Program	42h	3	-	1	Programs one byte of data in the OTP memory space.
Read OTP Data Bytes	4Bh	3	1	1 to infinite	Reads data in the OTP memory space. For details refer to Section 9.1.2, "Reading OTP Data" on page 36.
Read ID	9Fh	-	-	1 to 3	Device ID: 1st Byte = MFG ID 2nd Byte = Upper Byte, 3rd Byte = Lower Byte
Release from DPD only	ABh	-	-	-	Brings the device out of DPD mode into standby mode after the t <sub>RDP</sub> latency.

**Table 15: SPI Command Set (Sheet 2 of 2)**

Instruction	Op Code	Addr Bytes	Dummy Bytes	Data Bytes	Name and Function
Deep Power-Down	B9h	—	—	—	Puts device in DPD mode, whereby all commands are ignored except the Release from DPD command (ABh).
Bulk Erase	C7h	—	—	—	Serially erases all main memory Sectors including the eight parameter blocks.
Sector Erase	D8h	3	—	—	Erases a 64 KB Memory Sector; when addressing a parameter block, it will erase all eight 8 KB parameter blocks.

### 8.2.1 Write SPI SR Command (01h)

The Write SR command allows the user to write to the writable Status Register bits (that is, SR[7, 4:2]). As with any command that writes to the device, the Write Enable command must be executed prior to the Write SR command to set the WEL bit. If the WEL bit is not set, the Write SR command will be ignored.

If the device is in Hardware Protect mode, the Write SR command will be ignored and the WEL bit will be unchanged.

Assuming the WEL bit is set and the device is not in Hardware Protect mode, the rising edge of S# updates the SR within the  $t_{\text{SHSL}}$  specification time. If the Write SR command is botched (rising S# edge does not occur after exactly sixteen clock cycles), the writable SR bits and the WEL bit will remain unchanged.

### 8.2.2 Page Program Command (02h)

The Page Program command programs 1 bit to 256 bytes of data within a 256-Byte-Aligned memory segment. This command is used for programming the main array; it is not used for OTP programming.

The command sequence consists of an 8-bit OP Code, followed by a 24-bit address, and then by the data bytes to be programmed. The data to be programmed must be in whole-byte granularity. Otherwise, the command sequence will be ignored. To program in bit granularity, the remainder of the bits within the data byte must be set to "1".

The input data stream is loaded into a 256-Byte program buffer. The starting address of the program buffer is A[7:0] of the user-supplied address, and all subsequent bytes from the input data stream are loaded sequentially into the program buffer. If the program buffer reaches its maximum address, it wraps over, and subsequent data bytes are sequentially loaded starting at the beginning of the program buffer.

If more than 256 bytes of data are provided in the command input stream, the program buffer will be over-written, replacing the data that was previously loaded. The command sequence ends when S# goes high. When the command sequence ends, the data in the program buffer is programmed in the 256-Byte-Aligned memory segment defined by A[23:8] of the user-supplied address.

A byte count is not required with this command. The end of the data stream is identified with the rising edge of S#.

As with any command that writes to the device or changes the memory contents, the Write Enable command must be executed prior to the Page Program command in order to set the WEL bit. If the WEL bit is not set, the Page Program command will be ignored.

If the WEL bit is set and the address is protected, the program operation will not occur. Instead, the P\_FAIL flag of the Status Register will set and the WEL bit will clear.

The Page Program command can be botched (cancelled) by failing to raise the S# edge on a whole-byte increment. The following occur if the Page Program command is botched:

- The WEL bit will not be cleared.
- SR Fail Flags (described in [Table 16](#)) will not be set.
- None of the bytes written into the program buffer will be programmed into the flash array.

Assuming the WEL bit is set, the address is unprotected, and the command is not botched, the rising edge of S# initiates the program operation. This program operation cannot be terminated without powering off the device, and doing so will result in unexpected data.

### 8.2.3 Read Data Bytes Command (03h)

The Read Data Bytes command requires a 3-byte address. After the last address byte is clocked in (on the rising clock edge), the first data bit is clocked out on the subsequent falling clock edge. Data clocks out continuously and sequentially as long as S# remains low. When the address reaches its maximum, it wraps back to zero. The Read Data Byte command supports up to 33.3 MHz.

### 8.2.4 Write Disable Command (04h)

The Write Disable command clears the WEL bit, which corresponds to bit SR1. Clearing the WEL bit disables the following commands:

- Write SR
- Page Program
- OTP Program
- Bulk Erase
- Parameter Block Erase
- Sector Erase

These commands can be re-enabled by executing the Write Enable command as described in [Section 8.2.6](#). The WEL bit is cleared at power-up.

### 8.2.5 Read SPI SR Command (05h)

The Read SR command continuously polls the SPI Status Register. As long as S# remains low, a refreshed version of the status register is continuously clocked out. The Read SR command does not require address bytes, data bytes or dummy bytes.

### 8.2.6 Write Enable Command (06h)

The Write Enable command sets the WEL bit, which corresponds to bit SR1. Setting the WEL bit enables the following commands:

- Write SR

- Page Program
- OTP Program
- Bulk Erase
- Parameter Block Erase
- Sector Erase

These commands can be disabled by executing the Write Disable command as described in [Section 8.2.4](#). The WEL bit is cleared at power-up.

### 8.2.7 Fast Read Data Bytes Command (0Bh)

The Fast Read Data Bytes command requires a 3-byte address. After the last address byte is clocked in (on the rising clock edge), a dummy byte latency occurs (8 clock cycles) before the first data bit is clocked out on the falling clock edge. Data clocks out continuously and sequentially as long as S# remains low. Refer to [Section 8.4.1, "Fast Read" on page 32](#) for a detailed description of the Fast Read Data Bytes command. When the address reaches its maximum, it wraps back to zero. The Fast Read Data Bytes command supports up to 68 MHz, but it requires a dummy byte to allow time for the first Read latency.

### 8.2.8 Clear SR Fail Flags Command (30h)

The Clear SR Fail Flags command resets bit SR5 (Erase Fail Flag) and bit SR6 (Program Fail Flag). It is not necessary to set the WEL bit before the Clear SR Fail Flags command is executed. The WEL bit will be unchanged after this command is executed.

### 8.2.9 Parameter Block Erase Command (40h)

The Parameter Block Erase command is used to erase an 8-KB Parameter block. The command sequence consists of the OP Code followed by an address within the targeted block.

As with any command that writes to the device or changes the memory contents, the Write Enable command must be executed prior to the Parameter Block Erase command in order to set the WEL bit. The Parameter Block Erase command will be ignored if the WEL bit is not set.

If the WEL bit is set and one of the following is true:

- the address is not an 8-KB Parameter Block Address
- the address is protected,

the erase operation will not occur. Instead, the E\_FAIL flag of the Status Register will set and the WEL bit will clear.

The Parameter Block Erase command can be botched (cancelled) by failing to raise the S# edge after exactly thirty-two clock cycles. If the Parameter Block Erase command is botched, the WEL bit will not clear and the E\_FAIL flag will not set.

Assuming the WEL bit is set, the address is an unprotected 8-KB Parameter Block address, and the command is not botched, the rising edge of S# initiates the erase operation. This erase operation cannot be terminated without powering off the device, and doing so will result in unexpected data.

### 8.2.10 OTP Program Command (42h)

The OTP Program command programs data in the OTP region, which is in a different address space from the main array data. Refer to [Section 9.1, "OTP Memory Space" on page 36](#) for details on the OTP region. The protocol of the OTP Program command is the same as the Page Program command, except that the OTP Program command requires exactly one byte of data; otherwise, the command will be ignored. To program the OTP in bit granularity, the rest of the bits within the data byte can be set to "1".

If the WEL bit is set and the address is not a valid OTP address, the program operation will not occur. Instead, the F\_FAIL flag of the Status Register will set and the WEL bit will clear.

The OTP memory space can be programmed one or more times, provided that the OTP memory space is not locked (as described in [Section 9.1.3, "Lock Protection Registers" on page 36](#)). Subsequent OTP programming can be performed only on the unprogrammed bits (that is, "1" data).

### 8.2.11 Read OTP Data Bytes Command (4Bh)

The Read OTP Data Bytes command reads data from the OTP region. Refer to [Section 9.1, "OTP Memory Space" on page 36](#) for details on the OTP region. The protocol of the Read OTP Data Bytes command is the same as the Fast Read Data Bytes command except that it will not wrap to the starting address after the OTP address is at its maximum; instead, the data will be indeterminate.

### 8.2.12 Read ID Command (9Fh)

The Read ID command reads three bytes of data. It does not require any address bytes, data bytes or dummy bytes. After inputting the OP code, three bytes are clocked out of the device: the MFG ID, the first byte of the Device ID, and the second byte of the Device ID. Refer to [Table 19, "Device ID Codes" on page 38](#) for the MFG ID and Device IDs of the S33 device. If S# is held low after the third byte of data, the subsequent data is indeterminate.

### 8.2.13 Release from DPD Command (ABh)

In Deep Power-Down mode, the only command that the SPI interface recognizes is the Release from DPD command. After issuing this command, the  $t_{RDP}$  latency is required before S# can go low to initiate another command. The only other way to release the device from DPD mode is to power it off and on.

When issuing a Release from DPD command, it is not necessary to raise S# after exactly eight clock cycles. After inputting the 8-bit OP Code, all subsequent bits in the command sequence will be ignored.

### 8.2.14 Deep Power-Down Command (B9h)

The Deep Power-Down command puts the device in DPD mode, whereby all commands are ignored except the Release from DPD command (ABh).

### 8.2.15 Bulk Erase Command (C7h)

The Bulk Erase command serially erases the entire main array, including the parameter blocks (but excluding the OTP memory space).

As with any command that writes to the device or changes the memory contents, the Write Enable command must be executed prior to the Bulk Erase command to set the WEL bit. The Bulk Erase command will be ignored if the WEL bit is not set.

If the WEL bit is set and there is at least one memory sector that is protected, the erase operation will not occur. Instead, the E\_FAIL flag of the Status Register will set and the WEL bit will clear.

The Bulk Erase command can be botched (cancelled) by failing to raise the S# edge after exactly eight clock cycles. If the Bulk Erase command is botched, the WEL bit will not clear and the E\_FAIL flag will not set.

Assuming the WEL bit is set, all memory sectors are unprotected, and the command is not botched, the rising edge of S# initiates the erase operation. This erase operation cannot be terminated without powering off the device, and doing so will result in unexpected data.

### 8.2.16 Sector Erase Command (D8h)

The Sector Erase command is used to erase a 64-KB memory sector. The command sequence consists of an 8-bit OP code followed by a 24-bit address. If the address is within the parameter block address range ( $A[\text{max}:16]=0$ ), all eight parameter blocks will be erased. (With this characteristic, the device behaves as a symmetrically blocked device.)

As with any command that writes to the device or changes the memory contents, the Write Enable command must be executed prior to the Sector Erase command in order to set the WEL bit. If the WEL bit is not set, the Sector Erase command will be ignored.

If the WEL bit is set and the address is protected, the erase operation will not occur. Instead, the E\_FAIL flag of the Status Register will set and the WEL bit will clear.

The Sector Erase command can be botched (cancelled) by failing to raise the S# edge after exactly 32 clock cycles. If the Sector Erase command is botched, the WEL bit will not clear and the E\_FAIL flag will not set.

Assuming the WEL bit is set, the address is an unprotected, and the command is not botched, the rising edge of S# initiates the erase operation. The erase operation cannot be terminated without powering off the device, and doing so will result in unexpected data.

## 8.3 Status Register Definition

The Status Register bit definition can be found in [Table 16](#). The Status Register has program/erase fail flags, and it contains writeable bits that define the program/erase protection within the Flash array. All Status Register bits are volatile.

**Table 16: Status Register Bit Definition**

SR Bit	Bit Name	Bit Description	Power-up State	Write/Read Capability
7	SRWD	<b>Status Register Write Disable</b> - When this writeable bit is set and W# is low, none of the writable SR bits can be changed including these bits (that is, SR7, 4:2). For details, refer to <a href="#">Table 18, "Main Array Protection Modes" on page 32</a> . This bit is volatile.	0	Read/Write <sup>(1)</sup>
6	P_FAIL	<b>Program Fail Flag</b> - When set, this bit indicates that a program failure occurred. This bit will also be set when the user attempts to program a protected main memory region or a locked OTP region. However, the Program Fail Flag will not be set under the following scenarios: <ul style="list-style-type: none"> <li>• Botched Command Sequence (that is, S# edge not raised on a whole-byte increment)</li> <li>• Write Enable Latch bit is reset (that is, SR1 = 0)</li> </ul> After a series of program operations, this bit indicates whether one or more of these operations failed. Once set, this bit is reset with the Clear SR Fail Flag command.	0	Read only <sup>(2)</sup>
5	E_FAIL	<b>Erase Fail Flag</b> - When set, this bit indicates that an erase failure occurred. This bit will also be set when the user attempts to erase a protected main memory region. However, the Erase Fail Flag will not be set under the following scenarios: <ul style="list-style-type: none"> <li>• Botched Command Sequence (that is, S# edge not raised on a whole-byte increment).</li> <li>• Write Enable Latch bit is reset (that is, SR1 = 0)</li> </ul> After a series of erase operations, this bit indicates whether one or more of the operations failed. Once set, this bit is reset with the Clear SR Fail Flag command.	0	Read only <sup>(2)</sup>
4	BP2	<b>Sector Protect Bits</b> - These bits define the lock region of the main memory. A locked region is one or more adjacent memory sectors that are protected from program or erase. For further details, refer to <a href="#">Table 17</a> . When all three of these bits are "0", the entire main array is unlocked. These bits are volatile; at power-up, these bits are set to "1".	1	Read/Write <sup>(1)</sup>
3	BP1		1	Read/Write <sup>(1)</sup>
2	BP0		1	Read/Write <sup>(1)</sup>
1	WEL	<b>Write Enable Latch</b> - This bit must be set prior to the following SPI Commands: <ul style="list-style-type: none"> <li>• Write SPI SR</li> <li>• Page Program</li> <li>• OTP Program</li> <li>• Bulk Erase</li> <li>• Parameter Block Erase</li> <li>• Sector Erase</li> </ul> After issuing one of these commands, the WEL bit will clear when the command is completed. The WEL bit will not be cleared if the command is botched by not raising S# on a whole-byte increment.	0	read only <sup>(3)</sup>
0	WIP	<b>Write in Process</b> - When a program, erase, or write to the SR is in process (busy), the WIP reads as "1". When the WIP bit is zero, the SPI interface is in its ready state.	0	read only
<b>Notes:</b> <ol style="list-style-type: none"> <li>1. Refer to <a href="#">Table 18, "Main Array Protection Modes" on page 32</a> for writable conditions.</li> <li>2. The Program and Erase Fail flags are not directly writable, but they can be reset with the Clear SR Fail Flag command. This is true regardless of the protection modes described in <a href="#">Table 18</a>.</li> <li>3. The WEL bit is not directly writable but it can be set with the Write Enable command and reset with the Write Disable command. This is true regardless of the protection modes described in <a href="#">Table 18</a>.</li> </ol>				

### 8.3.1 Main Memory Protection

Main memory program/erase protection is defined by three Status Register bits (SR[4:2]) and the W# input signal. [Table 17](#) defines the memory protection regions. [Table 18](#) defines the SR and W# configurations for Software Protection Mode and Hardware Protection Mode.

**Table 17: Main Array Protection Regions - Bottom Boot**

Status Register Bits			Protected Main Memory Sectors		
BP2	BP1	BP0	64 M	32 M	16 M
0	0	0	None	None	None
0	0	1	Sectors 126 - 127 (upper 1/64)	Sector 63 (upper 1/64)	Sector 31 (upper 1/32)
0	1	0	Sectors 124 - 127 (upper 1/32)	Sectors 62 - 63 (upper 1/32)	Sectors 30 - 31 (upper 1/16)
0	1	1	Sectors 120 - 127 (upper 1/16)	Sectors 60 - 63 (upper 1/16)	Sectors 28 - 31 (upper 1/8)
1	0	0	Sectors 112 - 127 (upper 1/8)	Sectors 56 - 63 (upper 1/8)	Sectors 24 - 31 (upper 1/4)
1	0	1	Sectors 96 - 127 (upper 1/4)	Sectors 48 - 63 (upper 1/4)	Sectors 16 - 31 (upper 1/2)
1	1	0	Sectors 64 - 127 (upper 1/2)	Sectors 32 - 63 (upper 1/2)	All Sectors
1	1	1	All Sectors	All Sectors	All Sectors

**Table 18: Main Array Protection Modes**

W# Signal	SRWD Bit (SR7)	Mode	Protection of SR
V <sub>IL</sub>	0	Software Protect	The SRWD bit (SR7) and the BP bits (SR[4:2]) are writable.
V <sub>IL</sub>	1	Hardware Protect	The SRWD bit (SR7) and the BP bits (SR[4:2]) are <b>not</b> writable. These bits cannot be altered without raising W# to V <sub>IH</sub> or device power-up. In this configuration, the Main Array Protection Regions cannot be changed.
V <sub>IH</sub>	0	Software Protect	The SRWD bit (SR7) and the BP bits (SR[4:2]) are writable.
V <sub>IH</sub>	1	Software Protect	The SRWD bit (SR7) and the BP bits (SR[4:2]) are writable.

## 8.4 SPI Instruction Cycle Examples

In this section, two SPI instruction cycles are explained in detail to provide a thorough understanding of SPI instruction cycles in general. The intent of these examples is to provide a foundation for all SPI instructions.

### 8.4.1 Fast Read

A Fast Read instruction uses 0Bh as an OP Code. After clocking in the OP Code, a 3-byte address is clocked in (starting with the MSB), followed by a dummy byte. The output serial data stream is clocked out on the falling edge of "C", one-half cycle after the last dummy bit is clocked in. The timing diagram for a Fast Read command sequence can be found in [Figure 15, "Timing Diagram for SPI Fast Read Command Sequence" on page 33](#).

Within the SPI interface, the address is automatically incremented internally as the data is clocked out continuously and sequentially, as long as S# remains low. The output data stream can be paused by bringing HOLD# low, and it can be continued by



bring it high again. When the internal address reaches the last address within the device's range, it will wrap to address 0h. When the user brings S# high, the instruction cycle is terminated, and the data output (Q) becomes tri-stated.

**Figure 15: Timing Diagram for SPI Fast Read Command Sequence**

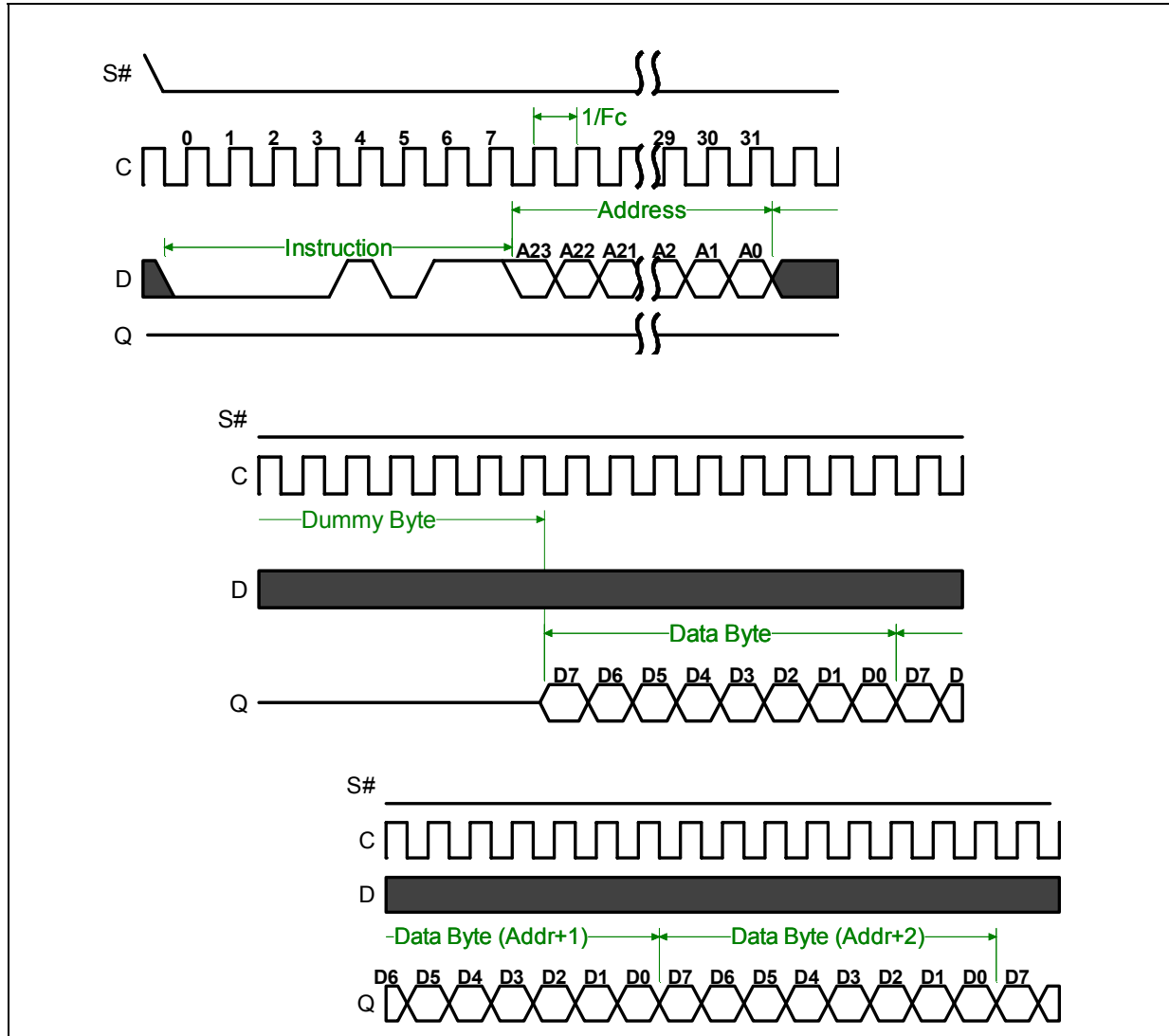

### 8.4.2 Page Program

A Page Program instruction consists of an OP Code (02h) followed by a 3-byte address and a variable number of data bytes, up to the size of the program buffer (page). Assuming S# goes high on a whole-byte increment, the SPI module will instruct the WSM to initiate programming, otherwise the Page Program instruction will botch (and nothing will be programmed). The timing diagram for a Page Program command sequence can be found in [Figure 16, "Timing Diagram for SPI Page Program Command Sequence" on page 34.](#)

To monitor when the program algorithm is complete, a Read SR command must be issued. The Read SR command is the only instruction that the device will recognize while a write is in process.

Figure 16: Timing Diagram for SPI Page Program Command Sequence

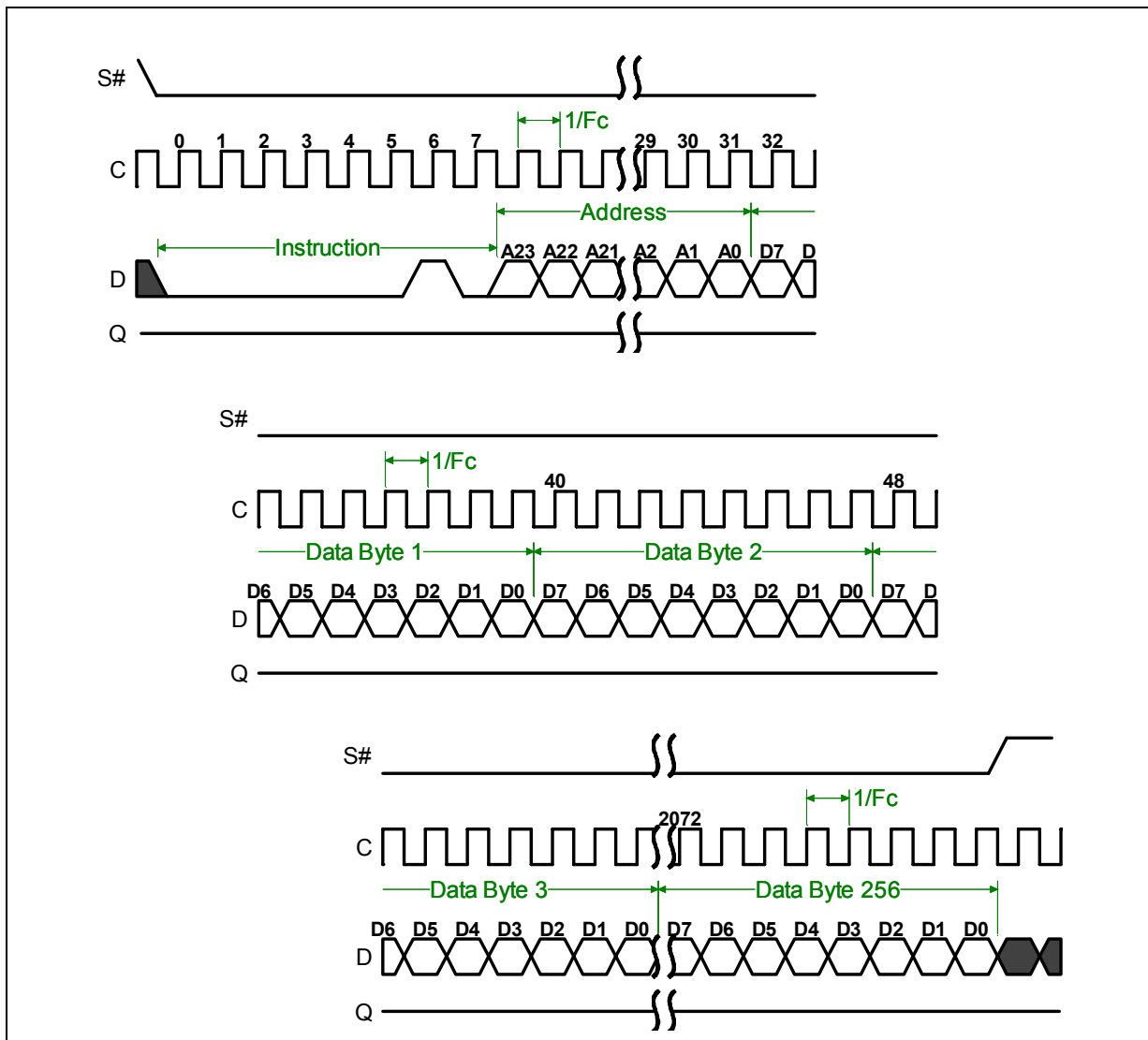

### 8.4.3 Write Enable

For write operations such as the Page Program operation, the single-byte Write Enable command sequence must be issued to set the WEL bit prior to issuing the Page Program operation. Without setting the WEL bit, the subsequent Page Program operation will be ignored. Just as with any other command that alters the configuration, the Write Enable command is completed on the rising edge of  $S\#$ . The timing diagram for a Write Enable command sequence can be found in [Figure 17, "Timing Diagram for Write Enable Command Sequence" on page 35.](#)

Figure 17: Timing Diagram for Write Enable Command Sequence

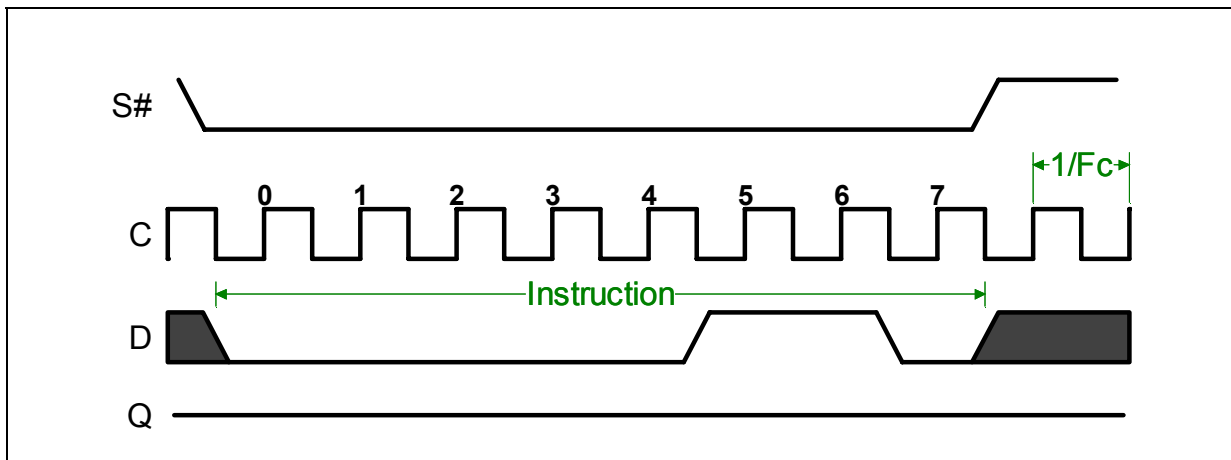

## 9.0 Security Features

This section describes the security features of the S33 device that go beyond the typical SPI Flash feature set.

### 9.1 OTP Memory Space

The S33 device contains two 8-Byte, thirty 16-Byte, and one 10-Byte individually-lockable OTP regions (Protection Registers) within an address space that is separate from the main array. Refer to [Figure 18, "OTP Memory Map" on page 37](#) for a pictorial representation of the OTP memory space.

The two 8-Byte Protection Registers are intended for increased system security. Protection Register values can "mate" a flash component with system CPU/ASIC to prevent device substitution. The Numonyx factory programs the lower 8-Byte Protection Register with a unique, unchangeable 64-bit number. The other 64 bits (upper 8-Byte) are blank so customers can program them for a similar purpose.

Once programmed, each customer segment (one of the 8-Byte segment, thirty 16-Byte segments, and one 10-Byte segment) can be locked to prevent further reprogramming.

#### 9.1.1 Programming OTP Address Space

For the description and SPI protocol of the OTP Program command, refer to [Table 15, "SPI Command Set" on page 25](#). The protocol of this command is the same as Page Program.

The OTP Program command can be issued multiple times to any given OTP address, but this address space can never be erased. After a given OTP segment is programmed, it can be locked to prevent further programming with the Lock Protection Registers, which are describe in [Section 9.1.3](#).

The valid address range for OTP Program is depicted in [Figure 18, "OTP Memory Map" on page 37](#). OTP Program operations outside the valid OTP address range will be ignored.

#### 9.1.2 Reading OTP Data

For the description and SPI protocol of the OTP Read command, refer to [Table 15, "SPI Command Set" on page 25](#). The protocol of this command is the same as Fast Read.

The valid address range for OTP Reads is depicted in [Figure 18, "OTP Memory Map" on page 37](#). OTP Read operations outside the valid OTP address range will yield indeterminate data.

#### 9.1.3 Lock Protection Registers

The Lock Protection Registers (PR-LOCK1, PR-LOCK2, and PR-LOCK3) are illustrated in [Figure 18, "OTP Memory Map" on page 37](#). PR-LOCK1 is used to permanently lock OTP addresses 0x102 through 0x111; PR-LOCK2 is used to permanently lock OTP addresses 0x114 through 0x213; PR-LOCK3 is used to permanently lock OTP addresses 0x216 through 0x2FF.

Figure 18: OTP Memory Map

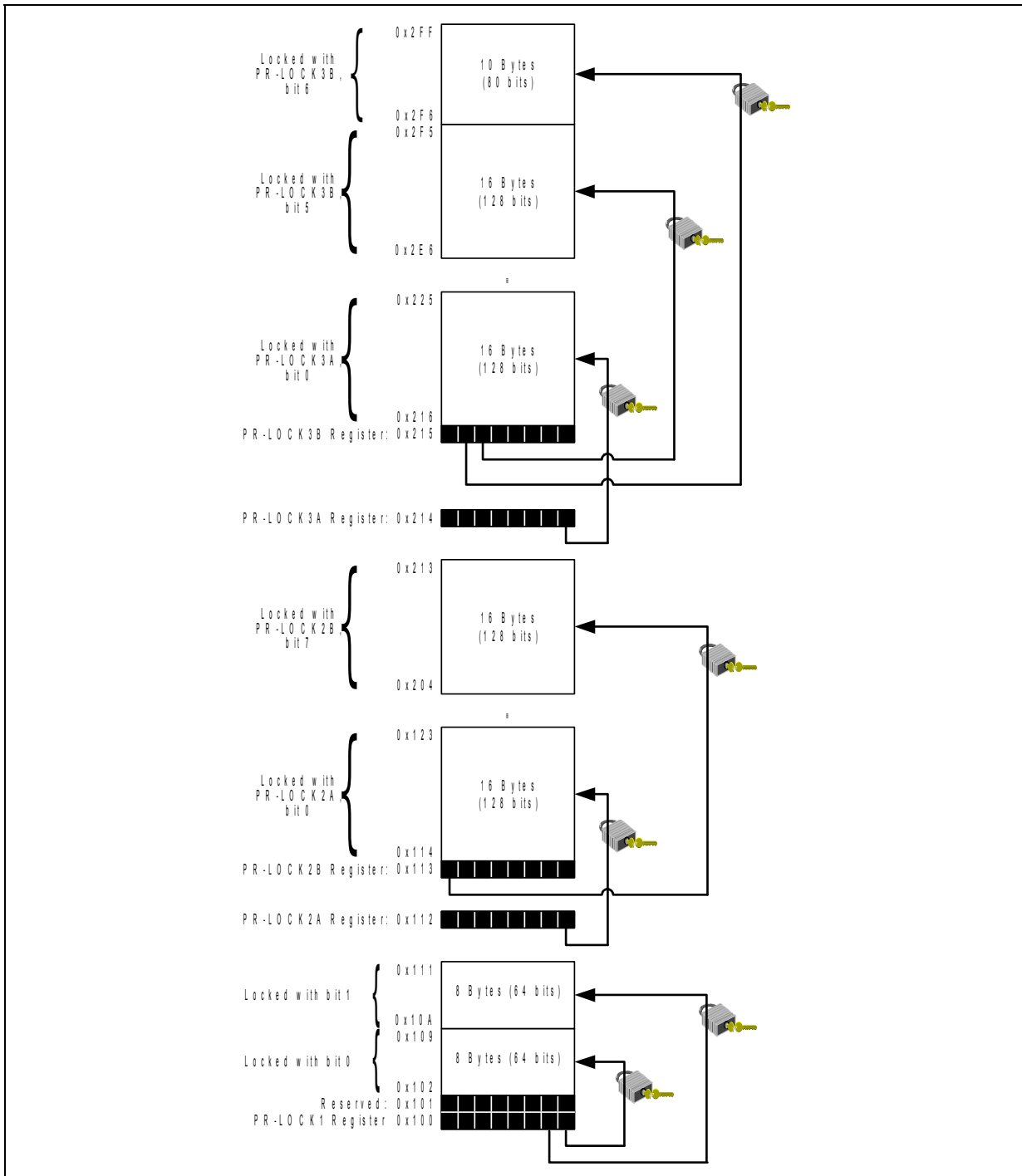

**Note:** OTP Bytes 0x102 through 0x109 will be programmed at Numonyx's factory with an unchangeable, unique identifier, and bit 0 of PR-LOCK1 register will be programmed to 0.

## 10.0 Numonyx™ Serial Flash Memory (S33) ID Codes

The Manufacturer ID is 89h, and the Device IDs are found in [Table 19](#).

Through the SPI Command Set, OP code 9Fh is required. The first byte of data read is the Manufacturer ID (89h); the second byte is the upper byte of the Device ID, and the third byte is the lower byte of the Device ID.

**Table 19: Device ID Codes**

Device	Device ID	Mode
Numonyx™ Serial Flash Memory (S33) 64M	8913	Bottom Boot
Numonyx™ Serial Flash Memory (S33) 32M	8912	Bottom Boot
Numonyx™ Serial Flash Memory (S33) 16M	8911	Bottom Boot

## Appendix A Write State Machine (WSM)

Table 20 and Table 21 shows the command state transitions (Next State Table) based on incoming commands.

**Table 20: Chip State and Output State Transitions (Sheet 1 of 2)**

Current Chip State	Command Input to Chip and Resulting Chip Next State (1 of 2)								
	Write SR	Page Program	Read Data Bytes	Write Disable	Read SR	Write Enable	Fast Read Data Bytes	Clear SR Fail Flags	Param Block Erase
	01h	02h	03h	04h	05h	06h	08h	30h	40h
<b>Ready, WEL bit = 0</b>	Ready, WEL bit = 0 (command ignored)								Ready, WEL bit = 0 (command ignored)
<b>Ready, WEL bit = 1</b>	Ready. If Software Protected, SR Write occurs and WEL=0. Else, command is ignored and WEL=1. (see note 1)	If targeted address is protected, device is Ready and WEL=1. Else, device is busy and WEL=x. (see note 2)	Ready, WEL bit does not change (Array Data Output)	Ready, WEL=0	Ready, WEL bit does not change (SR Output)	Ready, WEL=1	Ready, WEL bit does not change (Array Data Output)	Ready, WEL bit does not change	If the targeted address is protected and a valid parameter block address, device is Ready and WEL bit = 1. Else, device is busy and WEL bit = x (see note 2)
<b>DPD, WEL bit = x</b>	DPD, WEL bit does not change (command ignored)								
<b>Busy</b>	Busy (command ignored)				Busy (SR Output)	Busy (command ignored)			

**Notes:**

1. Refer to [Table 18](#) for details on HW/SW protection.
2. Refer to [Table 18](#) for details on address protection.
3. Refer to [Section 9.0, "Security Features"](#) for details on OTP protection.
4. Refer to [Table 16](#) for details on the Status Register.

**Table 21: Chip State and Output State Transitions (Sheet 2 of 2)**

Current Chip State	Command Input to Chip and resulting Chip Next State (2 of 2)								
	OTP Program	Read OTP Data Bytes	Read JEDEC ID	Release from DPD	Deep Power-Down	Bulk Erase	Sector Erase	Power Cycle (off, then on)	Program or Erase Operation Completes
	42h	4Bh	9Fh	ABh	B9h	C7h	D8h		
<b>Ready, WEL bit = 0</b>	Ready, WEL bit = 0 (command ignored)	Ready, WEL bit does not change (OTP Data Output)	Ready, WEL bit does not change (ID Output)	Ready, WEL bit does not change	DPD, WEL bit does not change	Ready, WEL=0 (command ignored)		Ready, SR = 1Ch (see note 4)	N/A
<b>Ready, WEL bit = 1</b>	If targeted address is protected, device is Ready and WEL bit = 1. Else, device is busy and WEL bit = x. (see note 3)					If any main memory is protected, device is Ready and WEL bit = 1. Else, device is busy and WEL bit = x. (see note 2)	If targeted address is protected, device is Ready and WEL bit = 1. Else, device is busy and WEL bit = x. (see note 2)		
<b>DPD, WEL bit = x</b>	DPD, WEL bit does not change (command ignored)					DPD, WEL bit does not change (command ignored)			
<b>Busy</b>	Busy (command ignored)								Ready, WEL bit = 0

**Notes:**

1. Refer to [Table 18](#) for details on HW/SW protection.
2. Refer to [Table 18](#) for details on address protection.
3. Refer to [Section 9.0, "Security Features"](#) for details on OTP protection.
4. Refer to [Table 16](#) for details on the Status Register.



## Appendix B Ordering Information

Figure 19: Ordering Information

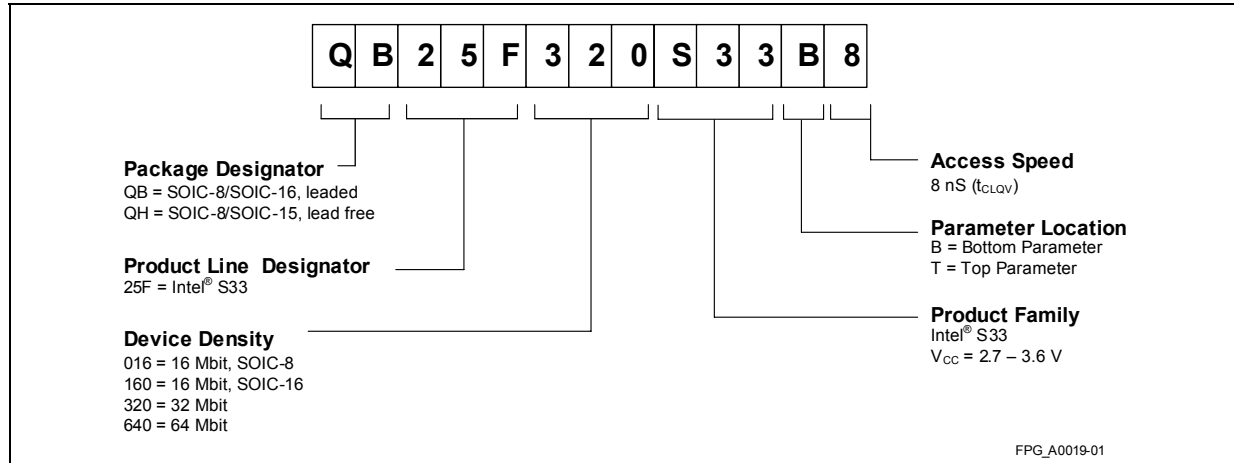

Table 22: Valid Combinations for Numonyx™ Serial Flash Memory (S33)

32 Mbit	16 Mbit	64 Mbit
QB25F320S33B8	QB25F016S33B8/QB25F160S33B8	QB25F640S33B8
QH25F320S33B8	QH25F016S33B8/QB25F160S33B8	QH25F640S33B8