

Customer Information Sheet

DRAWING No.: R40-100XX02 SHEET 2 OF 2 IF IN DOUBT - ASK (C) NOT TO SCALE THIRD ANGLE PROJECTION ALL DIMENSIONS IN mm

ALL SPACERS UP TO & INCLUDING 28mm

22 TO 28mm SPACERS DO NOT HAVE A THROUGH TAPPED HOLE, BUT HAVE A MINIMUM THREAD LENGTH OF 10mm FROM BOTH ENDS.

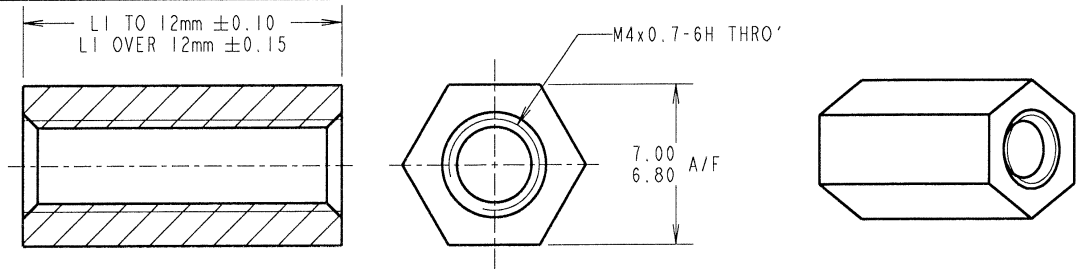

ALL SPACERS OVER 28mm

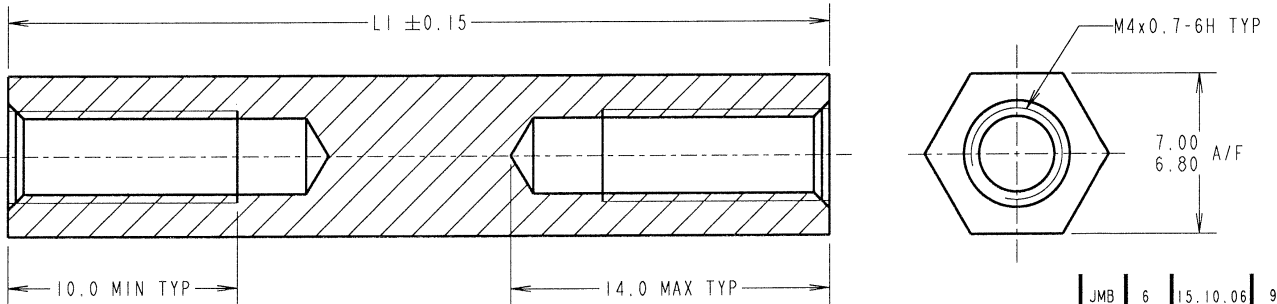

PART No.	LI	PART No.	LI	PART No.	LI	PART No.	LI
R40-1000502	5.00	R40-1001002	10.00	R40-1001502	15.00	R40-1002602	26.00
R40-1000602	6.00	R40-1001102	11.00	R40-1001602	16.00	R40-1003002	30.00
R40-1000702	7.00	R40-1001202	12.00	R40-1001802	18.00	R40-1003602	36.00
R40-1000802	8.00	R40-1001302	13.00	R40-1002002	20.00	R40-1006002	60.00
R40-1000902	9.00	R40-1001402	14.00	R40-1002502	25.00		

ORDER CODE:
R40-100XX02
LENGTH LI IN mm

JMB	6	15.10.06	9512
NAME	ISS.	DATE	C/NOTE
APPROVED: <i>[Signature]</i>			
CHECKED: <i>[Signature]</i>			
DRAWN: D BECK			
CUSTOMER REF.:			
ASSEMBLY DRG:			

HARWIN

HARWIN INC U.S.A. TEL: (812) 542 2540 FAX: (812) 542 2541	HARWIN PLC U.K. TEL: 023 9231 4545 FAX: 023 9231 4590	HARWIN PTE SINGAPORE TEL: 65 6779 4909 FAX: 65 6779 3868
--	--	---

THIS DRAWING AND ANY INFORMATION OR DESCRIPTIVE MATTER SET OUT HEREON ARE CONFIDENTIAL AND COPYRIGHT PROPERTY OF THE HARWIN GROUP AND MUST NOT BE DISCLOSED, LOANED, COPIED OR USED FOR MANUFACTURING, TENDERING OR FOR ANY OTHER PURPOSE WITHOUT THEIR WRITTEN PERMISSION.

TOLERANCES
X. = ±1mm
X.X = ±0.25mm
X.XX = ±0.10mm
X.XXX = ±0.01mm
ANGLES = ±5°
UNLESS STATED

MATERIAL: BRASS
CW614N M TO BS EN 12164
(CuZn39Pb3)
FINISH: NICKEL
S/AREA: mm²

TITLE: M4 HEXAGONAL FEMALE SPACER

DRAWING NUMBER: R40-100XX02

SHT
2 OF 2