

D3FP3**30V 3A****特長**

- 小型SMD
- 超低 $V_F=0.4V$

Feature

- Small SMD
- Ultra-Low $V_F=0.4V$

用途

- バッテリー逆接防止
- DC出力OR用
- DC/DCコンバータ
- 携帯電話、パソコン

Main Use

- Reverse connect protection for DC power source
- DC OR-output
- DC/DC Converter
- Mobile phone, PC

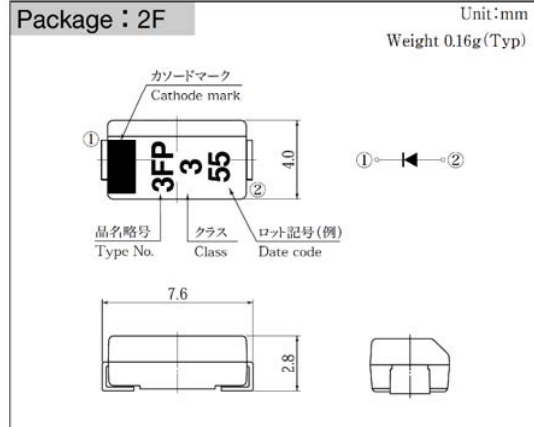
■外観図 OUTLINE

外形図については新電元Webサイト又は〈半導体製品一覧表〉をご参照下さい。捺印表示については捺印仕様をご確認下さい。
For details of the outline dimensions, refer to our web site or Semiconductor Short Form Catalog. As for the marking, refer to the specification "Marking, Terminal Connection".

■定格表 RATINGS**●絶対最大定格 Absolute Maximum Ratings (指定のない場合 $T_I = 25^\circ C$)**

項目 Item	記号 Symbol	条件 Conditions	品名 Type No.	D3FP3	単位 Unit
保存温度 Storage Temperature	T_{stg}			-55~125	$^\circ C$
接合部温度 Operation Junction Temperature	T_j			125	$^\circ C$
せん頭逆電圧 Maximum Reverse Voltage	V_{RM}			30	V
繰り返しせん頭サージ逆電圧 Repetitive Peak Surge Reverse Voltage	V_{RRSM}	パルス幅0.5ms, duty 1/40 Pulse width 0.5ms, duty 1/40		35	V
出力電流 Average Rectified Forward Current	I_O	50Hz正弦波, 抵抗負荷, $T_I = 74^\circ C$ 50Hz sine wave, Resistance load, $T_I = 74^\circ C$		3	A
せん頭サージ順電流 Peak Surge Forward Current	I_{FSM}	50Hz正弦波, 非繰り返し1サイクルせん頭値, $T_j = 25^\circ C$ 50Hz sine wave, Non-repetitive 1 cycle peak value, $T_j = 25^\circ C$		150	A

●電氣的・熱的特性 Electrical Characteristics (指定のない場合 $T_I = 25^\circ C$)

順電圧 Forward Voltage	V_F	$I_F = 1.6A$, パルス測定 Pulse measurement	MAX 0.35	V	
		$I_F = 4A$, パルス測定 Pulse measurement	MAX 0.40		
逆電流 Reverse Current	I_R	$V_R = V_{RM}$, パルス測定 Pulse measurement	MAX 10	mA	
接合容量 Junction Capacitance	C_j	$f = 1MHz, V_R = 10V$	TYP 300	pF	
熱抵抗 Thermal Resistance	$\theta_{j\ell}$	接合部・リード間 Junction to lead	MAX 24	$^\circ C/W$	
		接合部・周囲間 Junction to ambient	アルミナ基板実装 On alumina substrate		MAX 90
			プリント基板実装 On glass-epoxy substrate		MAX 120

■特性図 CHARACTERISTIC DIAGRAMS

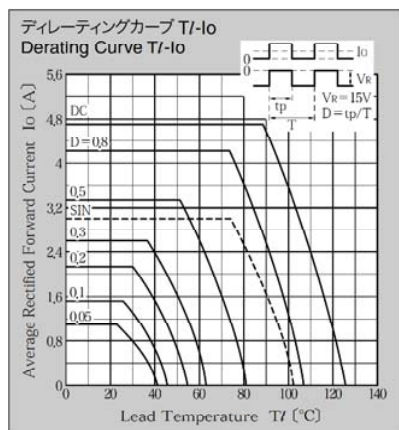
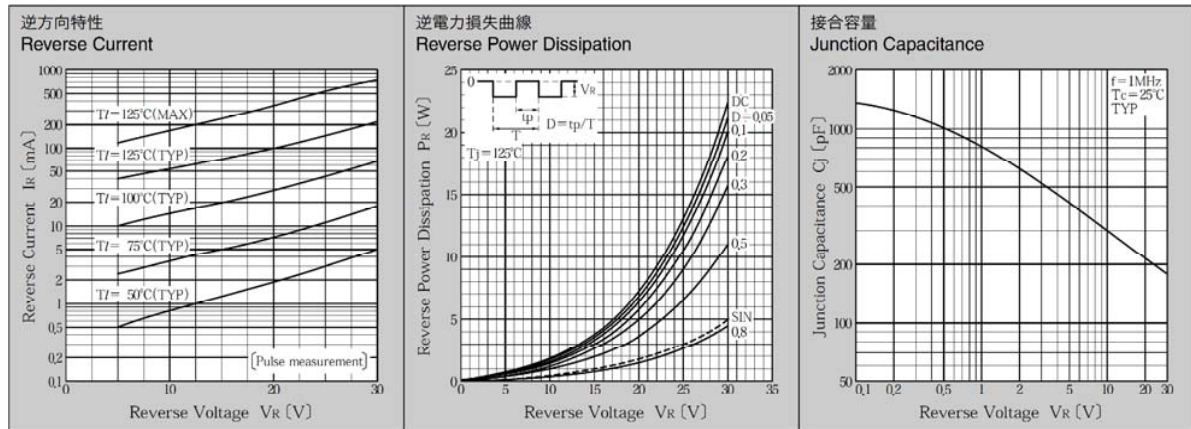
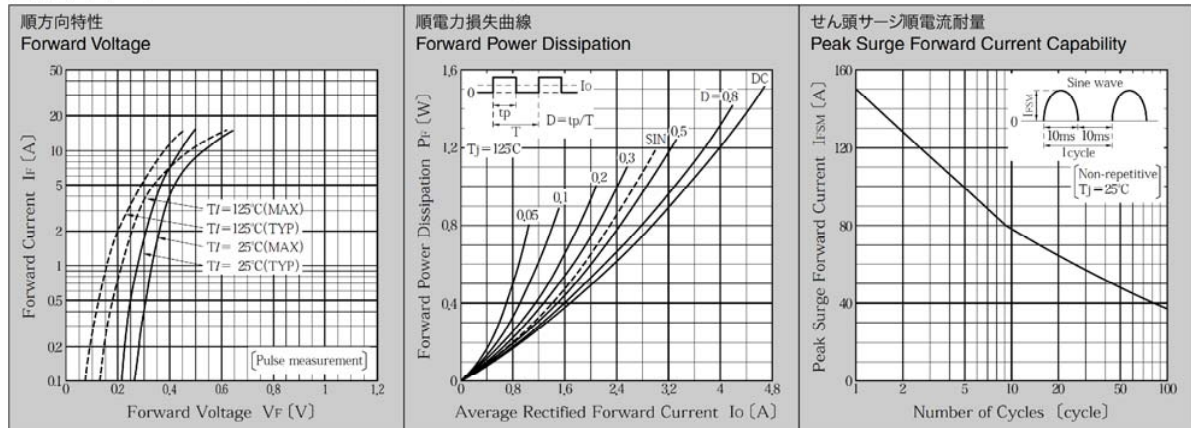

* Sine waveは50Hzで測定しています。
* 50Hz sine wave is used for measurements.
* 半導体製品の特性は一般的にバラツキを持っており、Typicalは統計的な実力を表しています。
* Semiconductor products generally have characteristic variation. Typical is a statistical average of the device's ability.