

# GL1500, 2500, 3500 SERIES

## IN-LINE HIGH CURRENT SILICON BRIDGE RECTIFIERS VOLTAGE - 50 to 800 Volts CURRENT - 15 to 35 Amperes

### FEATURES

- Plastic Case With Heatsink For Heat Dissipation
- Surge Overload Ratings to 400 Amperes
- The plastic package has Underwriters Laboratory Flammability Classification 94V-O

### MECHANICAL DATA

Case: Molded plastic with heatsink integrally mounted in the bridge Encapsulation

Weight: 1 ounce, 30 grams

Mounting position: Any

Terminals: Wire Lead 50 mils

### GL

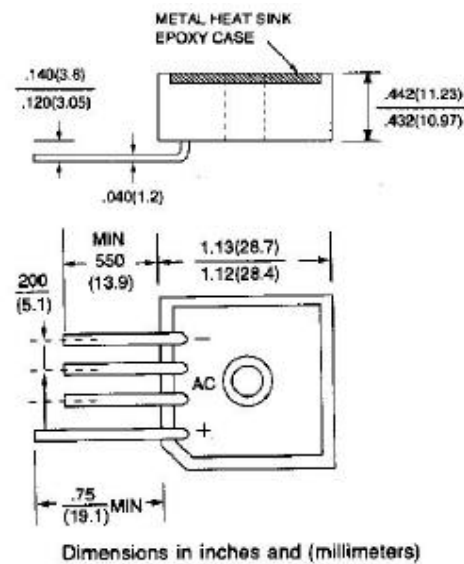

### MAXIMUM RATINGS AND ELECTRICAL CHARACTERISTICS

Inductive or resistive Load at 60Hz. For capacitive load derate current by 20%.

All Ratings are for  $T_C=25$  unless otherwise specified.

	-00	-01	-02	-04	-06	-08	UNITS
Max Recurrent Peak Reverse Voltage	50	100	200	400	600	800	V
Max RMS Input Voltage	35	70	140	280	420	560	V
Max DC Blocking Voltage	50	100	200	400	600	800	V
DC Output Voltage, Resistive Load	30	62	124	250	380	505	V
DC Output Voltage, Capacitive Load	50	100	200	400	600	800	V
Max Average Forward Current for Resistive Load at $T_C=55$	GL15			15			A
	GL25			25			A
	GL35			35			A
Non-repetitive Peak Forward Surge Current at Rated Load	GL15			300			A
	GL25			300			A
	GL35			400			A
Max Forward Voltage per Bridge Element at Specified Current	GL15 $I_F$ 7.5A						
	GL25 12.5A			1.2			V
	GL35 17.5A						
Max Reverse Leakage Current @ $T_A=25$ at Rated DC Blocking Voltage @ $T_A=100$				10			A
				1000			
$I^2t$ Rating for fusing ( $t < 8.3ms$ )				374 / 664			$A^2s$
Typical Thermal Resistance (Fig. 3) $R_{JC}$				2.0			$^{\circ}W$
Operating Temperature Range $T_J$				-55 to +150			
Storage Temperature Range $T_A$							

RATING AND CHARACTERISTIC CURVES

GL1500 THRU GL3500

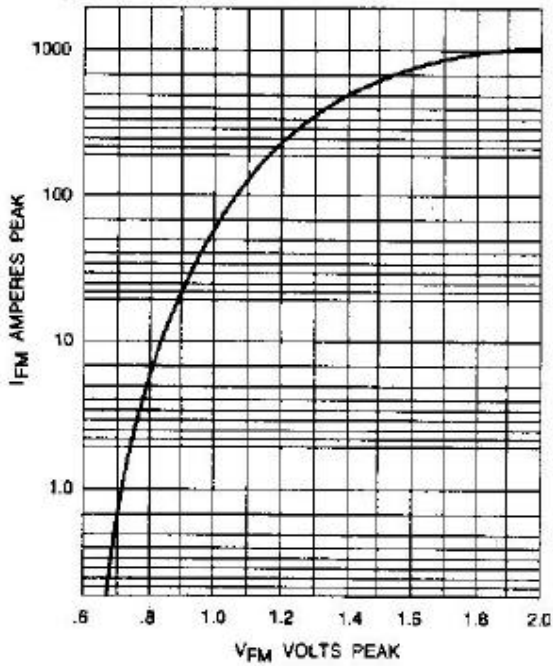

Fig. 1-TYPICAL INSTANTANEOUS FORWARD CHARACTERISTICS AT  $T_J=25$

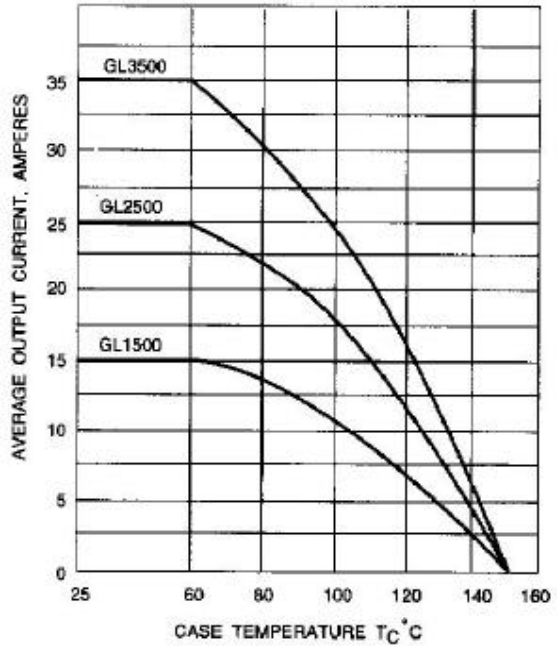

Fig. 2-OUTPUT CURRENT VS. CASE TEMPERATURE RESISTIVE OR INDUCTIVE LOAD  $T_J=175$

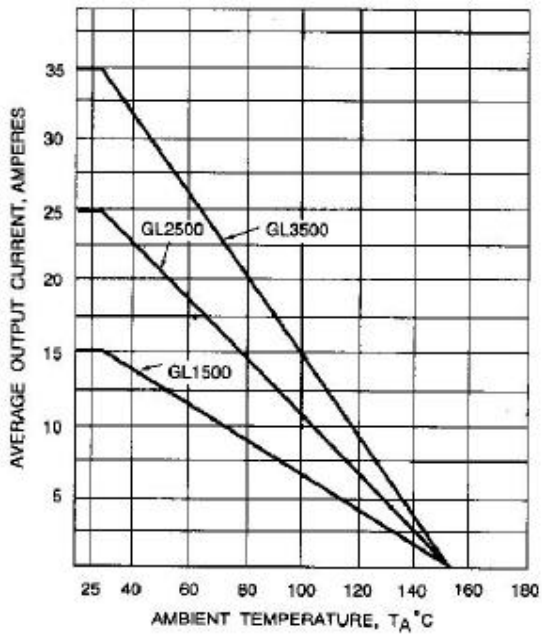

Fig. 3-OUTPUT CURRENT VS. AMBIENT TEMPERATURE RESISTIVE OR INDUCTIVE LOAD BRIDGE MOUNTED ON A8"x8" ALUMINUM PLATE 25" THICK

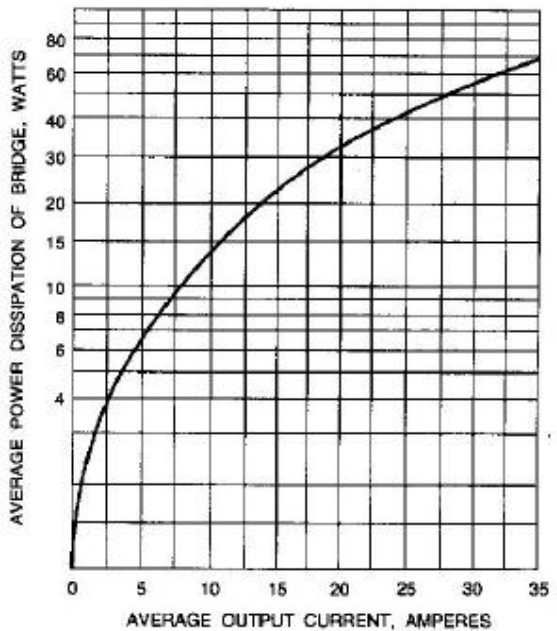

Fig. 4-POWER DISSIPATION VS. AVERAGE OUTPUT CURRENT RESISTIVE OR INDUCTIVE LOAD,  $T_J=175$