

## BLUTONIUM® BLUETOOTH® EDR SINGLE-CHIP HCI SOLUTION

### FEATURES

- Best-in-class Bluetooth® EDR solution in 0.13  $\mu\text{m}$  CMOS technology
- Built-in output power amplifier supports class 1 transmission
- Fully integrated balun and T/R switch eliminates all external RF matching components
- Supports class 1, 2, and 3 designs
- Bluetooth 1.1, 1.2, 2.0, and 2.1 standards are fully supported, including 1-, 2-, and 3-Mbps EDR operation
- Lowest current consumption in all modes of operation
- ROM-based solution available to eliminate external flash and/or EEPROM memory
- Highest available Bluetooth radio performance of any single-chip solution
  - -90 dBm typical receiver sensitivity using EDR communication
  - Programmable output power up to +10 dBm
- External BOM requirements of less than 10 external passive components
- Supports high-speed UART baud rate of up to 4 Mbps, USB 2.0 full-speed compliant interface, SDI, and eSPI HCI transports
- Fractional-N frequency synthesizer supports any crystal or TCXO source from 12 MHz to 40 MHz
- Automatic calibration and frequency detection of crystal frequency
- Proprietary packet prioritization scheme allowing two simultaneous A2DP applications

### SUMMARY OF BENEFITS

- Maximizes range and simplifies system integration by providing exceptional output power and receiver sensitivity
- High level of integration eliminates challenges of board level RF design
- Achieves smallest board area requirements by minimal external BOM and smallest package size available today
  - Standard PCB requirement is less than 50 mm<sup>2</sup>
  - Module solutions less than 25 mm<sup>2</sup>
- ROM-based solution with flexible code patching ensures fast integration
- On-chip voltage regulator lowers BOM requirements and provides additional power savings capability
- Minimized power dissipation over other solutions
  - 50% power savings in standard telephony headset applications
  - 30% power savings in advanced stereo audio applications

### APPLICATIONS

- Cellular and mobile communication devices
- PDA and low-power embedded communication devices
- PC and integration on PC mother board applications
- Package types available
  - 95-pin fpBGA package (6 mm x 6 mm)
  - 65-pin fpBGA package (5 mm x 5 mm)
  - Wafer scale flip chip packaging

#### Typical Cell Phone Application

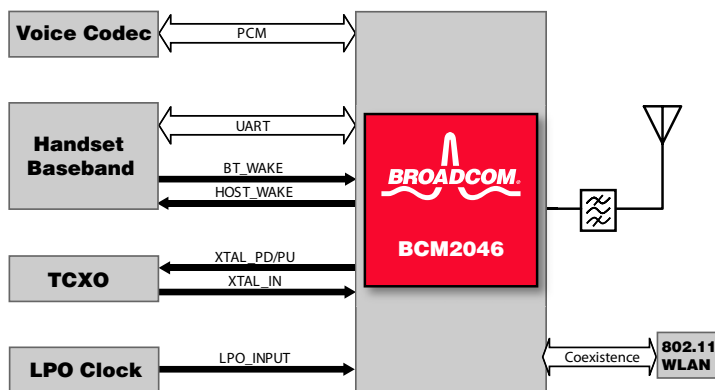

#### Typical PC Application

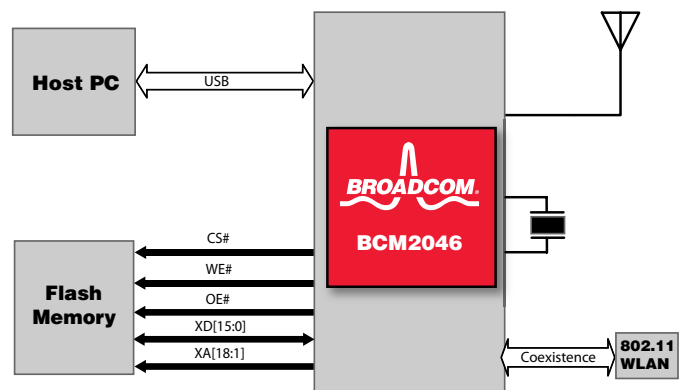

# OVERVIEW

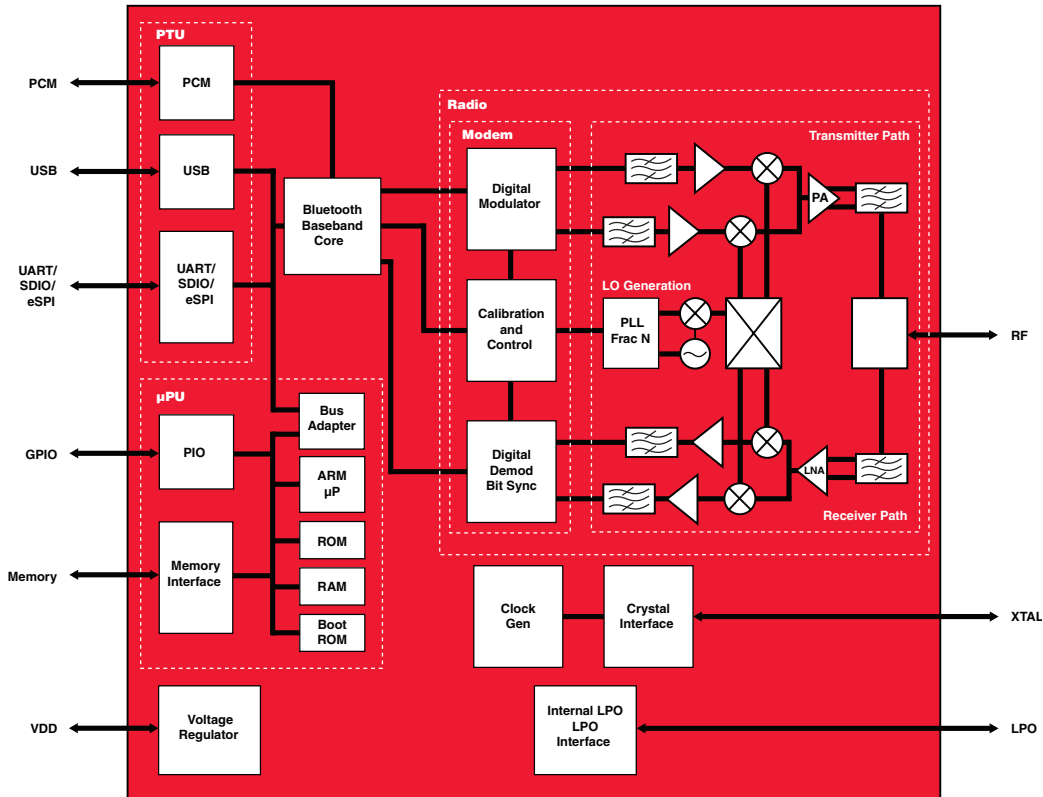

**BCM2046 Block Diagram**

The Broadcom BCM2046 is a monolithic, single-chip, stand-alone baseband processor with an integrated 2.4-GHz transceiver for Bluetooth Enhanced Data Rate (EDR) applications. It is fully compliant with Bluetooth 2.1 features such as Simple Pairing (SP) and Enhanced Inquiry Response (EIR). The BCM2046 is also completely backward-compatible with any prior Bluetooth versions. The ROM-based solution eliminates the need for external flash memories and active components by integrating critical components into the device, thus minimizing the footprint and system cost of implementing a Bluetooth system.

The BCM2046 EDR solution has been designed in 0.13μm bulk CMOS technology, the most widely available silicon process today. This use of the advanced process enables the BCM2046 to achieve the lowest possible current consumption in all modes of operation and maintain the lowest cost total solution.

The BCM2046 has an architecture that has been designed to take advantage of the EDR standard. Its superior integrated RF design enables higher output power and lower input sensitivity which makes the BCM2046 the ideal solution to support Bluetooth EDR. The built-in Class 1 PA combats interference and reduces dropped connections that

can result from distance and physical obstructions. This translates directly into higher and more reliable throughput and greater link range performance. A higher speed UART interface of up to 4 Mbps has been added to the BCM2046 for faster communication. The BCM2046 also includes industry collaborative coexistence solutions with WLAN systems. By using Broadcom's proprietary packet prioritization scheme, the BCM2046 is the industry's first Bluetooth product that is capable of supporting two simultaneous A2DP applications.

Cost optimized solutions can be achieved with the BCM2046 by using standard chip-on-board assembly techniques. Low risk applications are enabled through the extensive integration of external passive and active components. All sensitive RF and analog portions of the Bluetooth radio and baseband have been integrated into the device including the most sensitive high-frequency matching components. This eliminates the possibility of board level interference and degradation in performance due to the environment and board level designs. Internal voltage regulation has been added to eliminate the need for a voltage regulator and the device is capable of operation using a noisy digital 1.8 to 3.6V power supply.

Broadcom®, the pulse logo, Connecting everything®, the Connecting everything logo, and Blutionium® are among the trademarks of Broadcom Corporation and/or its affiliates in the United States, certain other countries and/or the EU. Bluetooth® is a trademark of the Bluetooth SIG. Any other trademarks or trade names mentioned are the property of their respective owners.

Connecting  
everything®



**BROADCOM CORPORATION**

5300 California Avenue  
Irvine, California 92617

© 2007 by BROADCOM CORPORATION. All rights reserved.

2046-PB04-R 12/12/07

Phone: 949-926-5000  
Fax: 949-926-5203  
E-mail: info@broadcom.com  
Web: www.broadcom.com