

M52723ASP

DYNAMIC FOCUS

DESCRIPTION

The M52723ASP is semiconductor integrated circuit for Multi-Sync display monitors. It generates horizontal and vertical parabola waves, and it can revise focus of CRT monitors.

FEATURES

- It can control phase of horizontal wave.
- It contains the horizontal saw wave generator and Auto Gain Control circuit, so that it is able to keep the amplitude constant if frequency change.
- It change the parabola wave inretrace period to constant voltage in order to reduce load at the amplitude after IC.

APPLICATION

CRT display monitor

RECOMMENDED OPERATING CONDITION

Supply voltage range.....11.5 to 12.5V
 Rated supply voltage.....12V

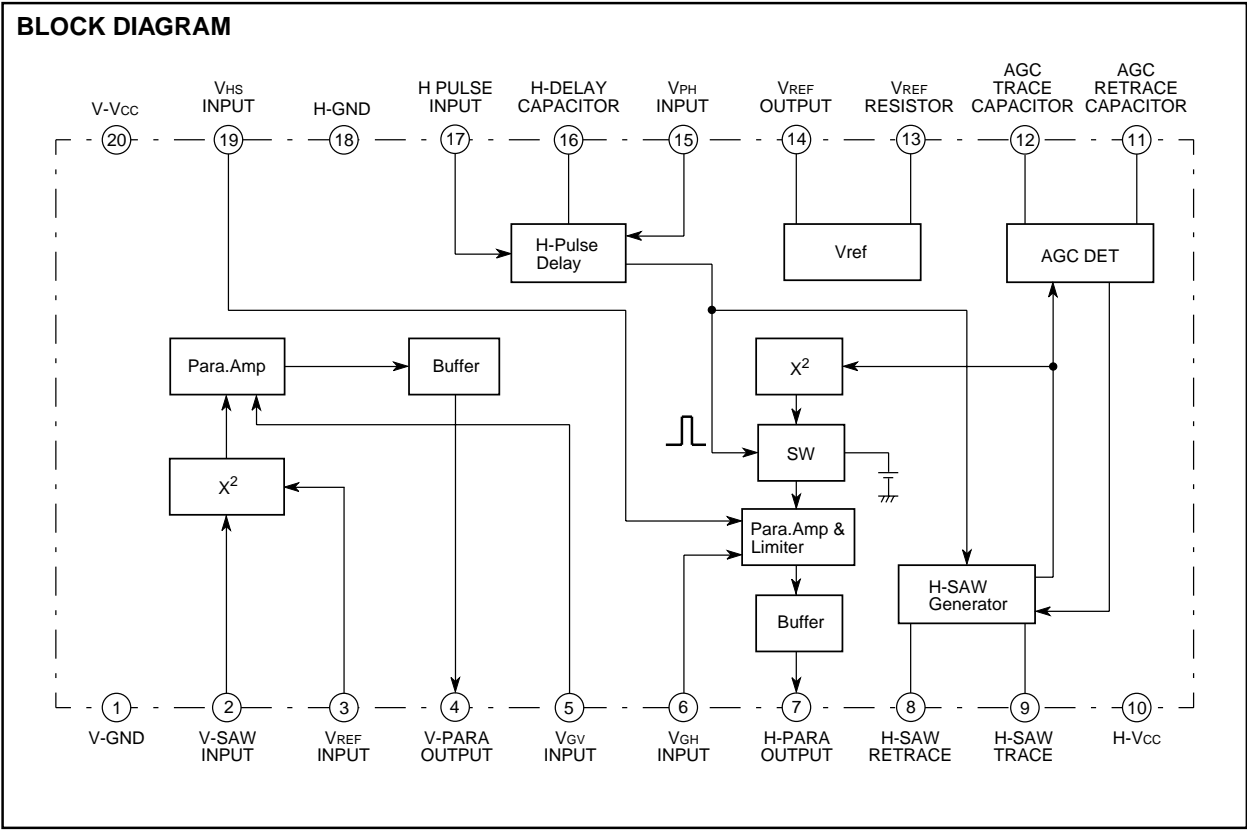
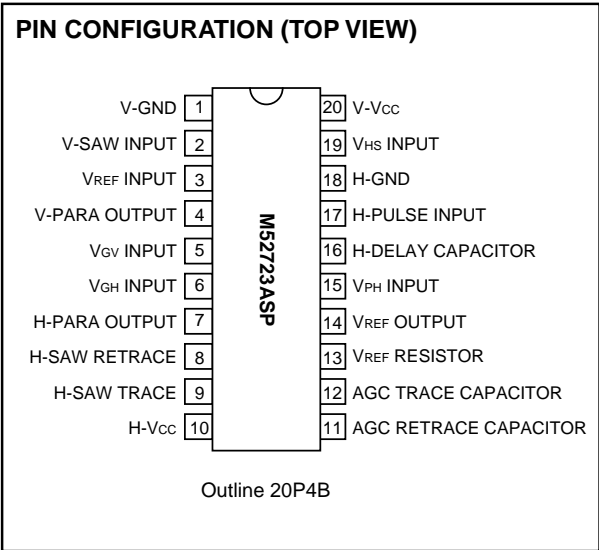

ABSOLUTE MAXIMUM RATINGS (Ta=25°C)

Symbol	Parameter	Ratings			Unit
		Min.	Typ.	Max.	
V _{CC}	Supply voltage	–	–	13.0	V
P _d	Power dissipation	–	–	1237.6	mW
T _{opr}	Operating temperature	-20	–	+85	°C
T _{stg}	Storage temperature	-40	–	+150	°C
V _{opr}	Recommended operating voltage	–	12.0	–	V
V _{opr'}	Recommended operating voltage range	11.5	–	12.5	V
V _{surge}	Surge	±200	–	–	V

ELECTRICAL CHARACTERISTICS (Ta=25°C, V_{CC}=12V, unless otherwise noted)

Symbol	Parameter	Test conditions	Pin No.	Limits			Unit
				Min.	Typ.	Max.	
I _{CCH}	Circuit current 1	(10) Measure	10	15.1	21.5	27.9	mA
I _{CCV}	Circuit current 2	(20) Measure	20	5.2	7.4	9.6	mA
V _{REF}	Reference voltage output	(14) Measure	14	6.75	6.95	7.15	V
D _{REF}	Reference voltage temperature drift	(14) Measure	14	–	49	–	ppm/deg
HORIZONTAL BLOCK							
V _{IL}	H-pulse low input range	(6) 4.0V in (7) Measure (15) 3.0V in (17) fH=50kHz H-pulse in (19) 3.2V in	7	0.0	–	2.0	V
V _{IH}	H-pulse high input range	(6) 4.0V in (7) Measure (15) 3.0V in (17) fH=50kHz H-pulse in (19) 3.2V in	7	3.0	–	V _{CC} -2.0	V
I _{IL}	H-pulse low input current	(17) 0V in, measure	17	-5.0	-0.6	-0.1	μA
I _{IH}	H-pulse high input current	(17) 5V in, measure	17	-1.0	0.0	1.0	μA
T _W	H parabola width	(6) 4.0V in (7) Measure (15) 3.0V in (17) fH=50kHz H-pulse in (19) 3.2V in	7	0.50	0.70	0.90	μsec
T _{D1}	H parabola delay 1	(6) 4.0V in (7) Measure (15) 0V in (17) fH=50kHz H-pulse in (19) 3.2V in	7	-0.09	0.09	0.35	μsec
T _{D2}	H parabola delay 2	(6) 4.0V in (7) Measure (15) 1.5V in (17) fH=50kHz H-pulse in (19) 3.2V in	7	0.19	0.41	0.65	μsec
T _{D3}	H parabola delay 3	(6) 4.0V in (7) Measure (15) 4.0V in (17) fH=50kHz H-pulse in (19) 3.2V in	7	2.65	2.95	3.20	μsec
D _D	Delay temperature drift	(6) 4.0V in (7) Measure (15) 3.0V in (17) fH=50kHz H-pulse in (19) 3.2V in	7	–	-0.08	–	ns/deg
I ₁₅	Pin15 input current	(15) 2.5V in, measure	15	-5.0	-0.4	-0.1	μA
V _{HP}	H parabola amplitude	(6) 2.5V in (7) Measure (15) 3.0V in (17) fH=50kHz H-pulse in (19) 4.0V in	7	7.5	8.2	8.9	V _{P-P}
F _{HP1}	H para. freq. characteristics 1	(6) 2.5V in (7) Measure (15) 3.0V in (17) fH=24kHz H-pulse in (19) 4.0V in	7	-0.2	0.0	0.2	V
F _{HP2}	H para. freq. characteristics 2	(6) 2.5V in (7) Measure (15) 3.0V in (17) fH=110kHz H-pulse in (19) 4.0V in	7	-0.2	0.0	0.2	V
V _{VHP1}	H para. V _{CC} characteristics 1	(6) 2.5V in (7) Measure (15) 3.0V in (10) (20) 11.5V in (17) fH=50kHz H-pulse in (19) 4.0V in	7	-0.1	0.0	0.1	V
V _{VHP2}	H para. V _{CC} characteristics 2	(6) 2.5V in (7) Measure (15) 3.0V in (10) (20) 12.5V in (17) fH=50kHz H-pulse in (19) 4.0V in	7	-0.1	0.0	0.1	V
D _{HP}	H para. size temperature drift	(6) 2.5V in (7) Measure (15) 3.0V in (17) fH=50kHz H-pulse in (19) 4.0V in	7	–	-275	–	ppm/deg
S _{HP1}	H para. size control 1	(6) 2.5V in (7) Measure (15) 3.0V in (17) fH=50kHz H-pulse in (19) 4.0V in	7	7.5	8.2	8.9	V _{P-P}
S _{HP2}	H para. size control 2	(6) 2.5V in (7) Measure (15) 3.0V in (17) fH=50kHz H-pulse in (19) 2.0V in	7	20	25	30	%
S _{HP3}	H para. size control 3	(6) 2.5V in (7) Measure (15) 3.0V in (17) fH=50kHz H-pulse in (19) 0V in	7	-5	0	5	%
G _{HP1}	H para. gain control 1	(6) 1.0V in (7) Measure (15) 3.0V in (17) fH=50kHz H-pulse in (19) 4.0V in	7	0.7	0.9	1.1	V _{P-P}
G _{HP2}	H para. gain control 2	(6) 2.5V in (7) Measure (15) 3.0V in (17) fH=50kHz H-pulse in (19) 4.0V in	7	4.2	4.7	5.2	–
G _{HP3}	H para. gain control 3	(6) 4.0V in (7) Measure (15) 3.0V in (17) fH=50kHz H-pulse in (19) 4.0V in	7	8.36	8.76	9.16	V _{P-P}

ELECTRICAL CHARACTERISTICS (cont.)

Symbol	Parameter	Test conditions	Pin No.	Limits			Unit
				Min.	Typ.	Max.	
DLI	H para. limit size temperature drift	(6) 4.0V in (7) Measure (15) 3.0V in (17) fH=50kHz H-pulse in (19) 4.0V in	7	–	106	–	ppm/deg
I ₆	Pin6 input current	(16) 2.5V in, measure	6	-5.0	-0.4	-0.1	μA
I ₁₉	Pin19 input current	(19) 2.0V in, measure	19	-5.0	-0.4	-0.1	μA
VERTICAL BLOCK							
AVP1	V parabola accuracy 1	(2) 1.9V in (3) 3.5V in (4) measure (5) 4.0V in	4	9.5	10.0	10.5	V
AVP2	V parabola accuracy 2	(2) 2.7V in (3) 3.5V in (4) measure (5) 4.0V in	4	6.23	6.73	7.23	V
AVP3	V parabola accuracy 3	(2) 3.5V in (3) 3.5V in (4) measure (5) 4.0V in	4	20	25	30	%
AVP4	V parabola accuracy 4	(2) 4.3V in (3) 3.5V in (4) measure (5) 4.0V in	4	20	25	30	%
AVP5	V parabola accuracy 5	(2) 5.1V in (3) 3.5V in (4) measure (5) 4.0V in	4	90	100	110	%
GVP1	V parabola amplitude 1	(2) fv=70Hz, 3.2V _{P-P} saw wave in (3) 3.5V in (4) measure (5) 1.0V in	4	0.0	0.0	0.1	V _{P-P}
GVP2	V parabola amplitude 2	(2) fv=70Hz, 3.2V _{P-P} saw wave in (3) 3.5V in (4) measure (5) 2.5V in	4	2.77	3.12	3.47	V _{P-P}
GVP3	V parabola amplitude 3	(2) fv=70Hz, 3.2V _{P-P} saw wave in (3) 3.5V in (4) measure (5) 4.0V in	4	6.26	6.56	6.86	V _{P-P}
FVP1	V para. freq. characteristics 1	(2) fv=50Hz, 3.2V _{P-P} saw wave in (3) 3.5V in (4) measure (5) 4.0V in	4	-0.1	0.0	0.1	V
FVP2	V para. freq. characteristics 2	(2) fv=185Hz, 3.2V _{P-P} saw wave in (3) 3.5V in (4) measure (5) 4.0V in	4	-0.1	0.0	0.1	V
VVP1	V para. Vcc. characteristics 1	(2) fv=70Hz, 3.2V _{P-P} saw wave in (3) 3.5V in (4) measure (5) 4.0V in	4	-0.1	0.0	0.1	V
VVP2	V para. Vcc. characteristics 2	(2) fv=70Hz, 3.2V _{P-P} saw wave in (3) 3.5V in (4) measure (5) 4.0V in	4	-0.1	0.0	0.1	V
DVP	V para. Vcc. temperature drift	(2) fv=70Hz, 3.2V _{P-P} saw wave in (3) 3.5V in (4) measure (5) 4.0V in	4	–	-325	–	ppm/deg
I ₂	Pin2 input current	(2) 3.5V in, measure	2	-5.0	-0.4	-0.1	μA
I ₃	Pin3 input current	(3) 3.5V in, measure	3	-5.0	-0.4	-0.1	μA
I ₅	Pin5 input current	(5) 2.5V in, measure	5	-5.0	-0.4	-0.1	μA

M52723ASP

DYNAMIC FOCUS

SWITCH AND VOLTAGE CONDITION

Symbol	Switch									Voltage (V)						
	SW2	SW3	SW5	SW6	SW10	SW15	SW17	SW19	SW20	Vcc	V2	V5	V6	V15	V17	V19
ICCH	a	a	a	a	b	a	b	a	a	12.0	3.5	2.5	2.5	3.0	0	2.0
ICCV					a				b							
VREF									a							
DREF							↓						↓		↓	↓
VIL							a						4.0		–	3.2
VIH							b						2.5		0	2.0
IIL							↓						↓		5.0	↓
IIH							a						4.0	↓	–	3.2
TW														0		
TD1														1.5		
TD2														4.0		
TD3														3.0	↓	↓
DD						↓	↓						↓	3.0	↓	↓
I15						b	b						2.5	–	0	2.0
VHP						a	a							3.0	–	4.0
FHP1																
FHP2										↓						
VVHP1										11.5						
VVHP2										12.5						
DHP										12.0						↓
SHP1																4.0
SHP2																2.0
SHP3																0
GHP1													1.0			4.0
GHP2													2.5			
GHP3													4.0			↓
DLI				↓			↓	↓					↓		↓	4.0
I6				b			b	↓					–		0	2.0
I19				a				b					2.5			–
AVP1								a					↓	4.0		2.0
AVP2													1.9			
AVP3													2.7			
AVP4													4.3			
AVP5	↓												5.1	↓		
GVP1	b												–	1.0		
GVP2														2.5		
GVP3														4.0		
FVP1																
FVP2										↓						
VVP1										11.5						
VVP2										12.5						
DVP	↓									12.0	↓	↓				
I2	c	↓									3.5	2.5				
I3	a	b	↓										↓			
I5	↓	a	b	↓	↓	↓	↓	↓	↓	↓	↓	–	↓	↓	↓	↓

INPUT SIGNAL

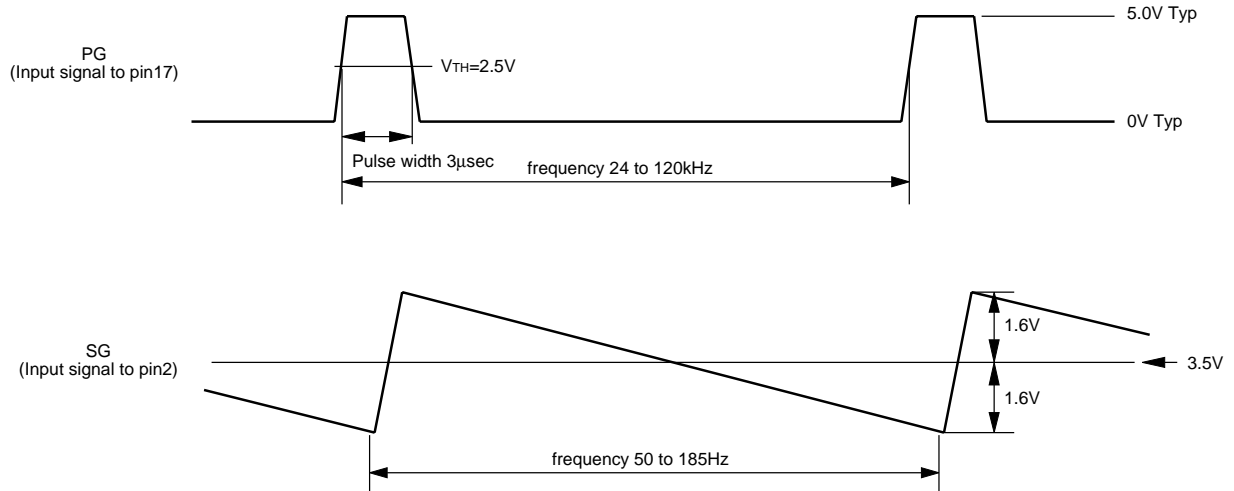

ELECTRICAL CHARACTERISTICS TEST METHOD

I_{ccH} Circuit current1

Measure the input current to pin10.

I_{ccV} Circuit current2

Measure the input current to pin20.

V_{REF} Reference voltage output

Measure the output voltage at pin14.

D_{REF} Reference voltage temperature drift

Measure temperature drift of pin14. (-20°C to 85°C)

V_{IL} H-pulse low input range

Input horizontal pulse which low level is 2V in pin17 and confirm output horizontal signal at pin7.

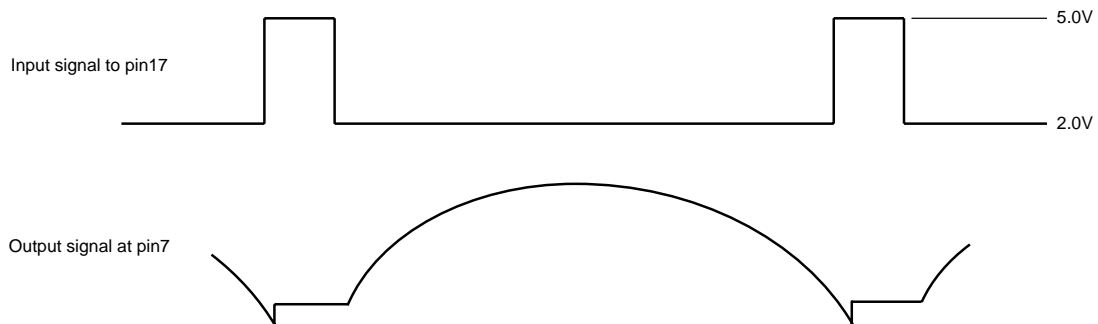

V_{IN} H-pulse high input range

Input horizontal pulse which high level is 3V in pin17 and confirm output horizontal signal at pin7.

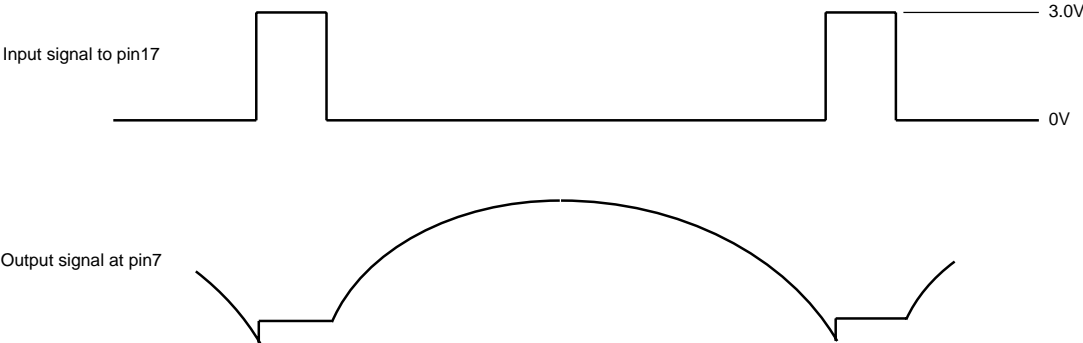

Tw H parabola width

Measure the time width of retrace period at pin 7.

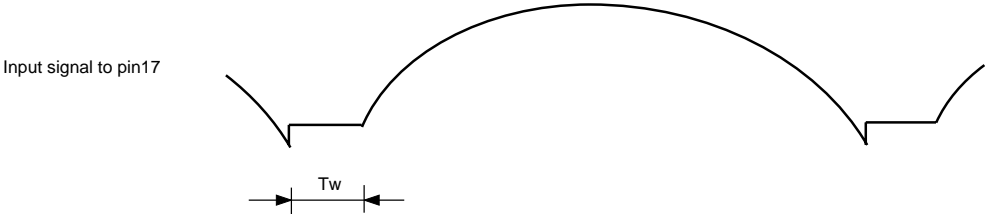

T_{D1} H parabola delay1, T_{D2} H parabola delay2, T_{D3} H parabola delay3

Measure the delay time from rise time of input signal to middle point of raise waveform point and down waveform point which voltage is retrace voltage +1.5V when the voltage of pin15 is 0V, 1.5V, and 4V.

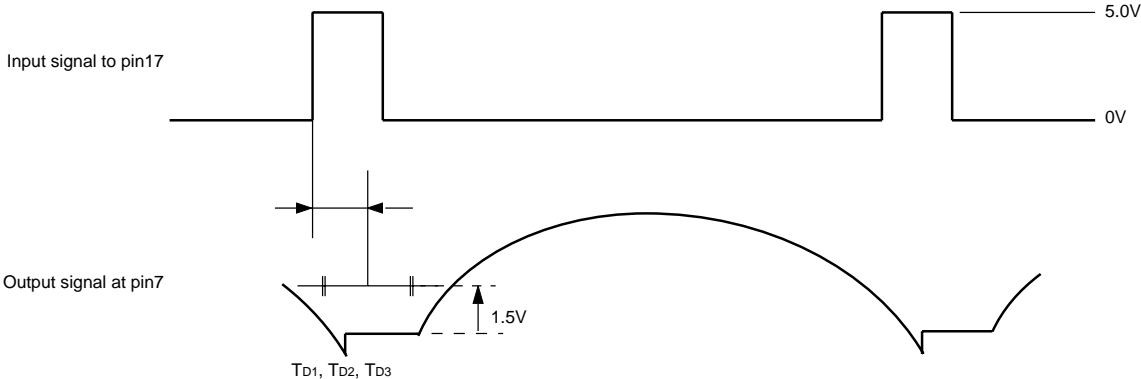

D₀ Delay temperature drift

Measure the temperature drift of the delay time. (-20°C to 85°C).

I₁₅ Pin15 input current

Measure the input current to pin15 when the voltage of pin15 is 2.5V.

V_{HP} H parabola amplitude

Measure the amplitude of parabola waveform at pin7 and it is defined HP_{50kHz}.

F_{HP1} H para. freq. characteristics1

When the frequency of input signal in pin17 is 24kHz, the amplitude of parabola waveform at pin7 is defined as HP_{24kHz}.

$$F_{HP1} = HP_{50kHz} - HP_{24kHz}$$

F_{HP2} H para. freq. characteristics2

When the frequency of input signal in pin17 is 120kHz, the amplitude of parabola waveform at pin7 is defined as HP_{120kHz}.

$$F_{HP2} = HP_{50kHz} - HP_{120kHz}$$

V_{VHP1} H para. Vcc. characteristics1

When the supply voltage of pin10, 20 is 11.5V, the amplitude of parabola waveform at pin7 is defined as HP_{11.5V}.

$$V_{VHP1} = HP_{50kHz} - HP_{11.5V}$$

V_{VHP2} H para. Vcc. characteristics2

When the supply voltage of pin10, 20 is 12.5V, the amplitude of parabola waveform at pin7 is defined as HP_{12.5V}.

$$V_{VHP2} = HP_{50kHz} - HP_{12.5V}$$

D_{HP} H para. size. temperature drift

Measure the temperature drift of HP_{50kHz}. (-20°C to 85°C)

S_{HP1} H para. size. control1

Measure the amplitude of parabola waveform at pin7 and it is defined as HP_{19 4.0V}.

S_{HP2} H para. size. control2

The amplitude of parabola waveform at pin7 is defined as HP_{19 2.0V}.

$$S_{HP2} = \frac{HP_{19 2.0V}}{HP_{19 4.0V}} \times 100 (\%)$$

S_{HP3} H para. size. control3

The amplitude of parabola waveform at pin7 is defined as HP_{19 0V}.

$$S_{HP3} = \frac{HP_{19 0V}}{HP_{19 4.0V}} \times 100 (\%)$$

G_{HP1} H para. gain control1

Measure the amplitude of parabola waveform at pin7 and it is defined as HP_{6 1.0V}.

G_{HP2} H para. gain control2

The amplitude of parabola waveform at pin7 is defined as HP_{19 2.5V}.

$$G_{HP2} = \frac{HP_{6 2.0V} - HP_{6 1.0V}}{1.5}$$

G_{HP3} H para. gain control3

Measure the amplitude of parabola waveform at pin7 (Limit level).

D_{L1} H para. limit size temperature drift

Measure temperature drift of G_{HP3}. (-20°C to 85°C)

I₆ Pin6 input current

Measure the input current to pin6 when voltage of pin6 is 2.5V.

I₁₉ Pin19 input current

Measure the input current to pin19 when voltage of pin19 is 2V.

AV_{P1} V parabola accuracy1

Measure the output voltage at pin4 and it is defined as VP_{2 3.5V}.

AV_{P2} V parabola accuracy2

The output voltage at pin4 is defined as VP_{2 1.9V}.

$$AV_{P2} = VP_{2 3.5V} - VP_{2 1.9V}$$

AV_{P3} V parabola accuracy3

The output voltage at pin4 is defined as VP_{2 2.7V}.

$$AV_{P3} = \frac{VP_{2 3.5V} - VP_{2 2.7V}}{VP_{2 3.5V} - VP_{2 1.9V}} \times 100 (\%)$$

AV_{P4} V parabola accuracy4

The output voltage at pin4 is defined as VP_{2 4.3V}.

$$AV_{P4} = \frac{VP_{2 3.5V} - VP_{2 4.3V}}{VP_{2 3.5V} - VP_{2 1.9V}} \times 100 (\%)$$

AV_{P5} V parabola accuracy5

The output voltage at pin4 is defined as VP_{2 5.1V}.

$$AV_{P5} = \frac{VP_{2 3.5V} - VP_{2 5.1V}}{VP_{2 3.5V} - VP_{2 1.9V}} \times 100 (\%)$$

G_{VP1} V parabola amplitude1, G_{VP2} V parabola amplitude2,**G_{VP3} V parabola amplitude3**

Measure the amplitude of parabola waveform at pin4 when the voltage of pin5 is 0V, 2.5V, and 4V.

When the voltage of pin5 is 4V, the amplitude of parabola waveform is defined as VP_{70Hz}.

F_{VP1} V para. freq. characteristics1

When the frequency of input signal in pin2 is 50Hz, the amplitude of parabola waveform at pin4 is defined as VP_{50Hz}.

$$F_{VP1} = VP_{70Hz} - VP_{50Hz}$$

F_{VP2} V para. freq. characteristics2

$$F_{VP2} = VP_{70Hz} - VP_{185Hz}$$

V_{VP1} V para. Vcc. characteristics1

When the voltage of pin10, 20 is 11.5V, the amplitude of parabola waveform is defined as VP_{11.5V}.

$$V_{VP1} = VP_{70Hz} - VP_{11.5V}$$

V_{VP2} V para. Vcc. characteristics2

When the voltage of pin10, 20 is 12.5V, the amplitude of parabola waveform is defined as VP_{12.5V}.

$$V_{VP2} = VP_{70Hz} - VP_{12.5V}$$

D_{VP} V para. temperature drift

Measure temperature drift of VP_{70Hz}. (-20°C to 85°C)

I₂ Pin2 input current

Measure the input current to pin2 when the voltage of pin2 is 3.5V.

I₃ Pin3 input current

Measure the input current to pin3 when the voltage of pin3 is 3.5V.

I₅ Pin5 input current

Measure the input current to pin5 when the voltage of pin5 is 3.5V.

TEST CIRCUIT

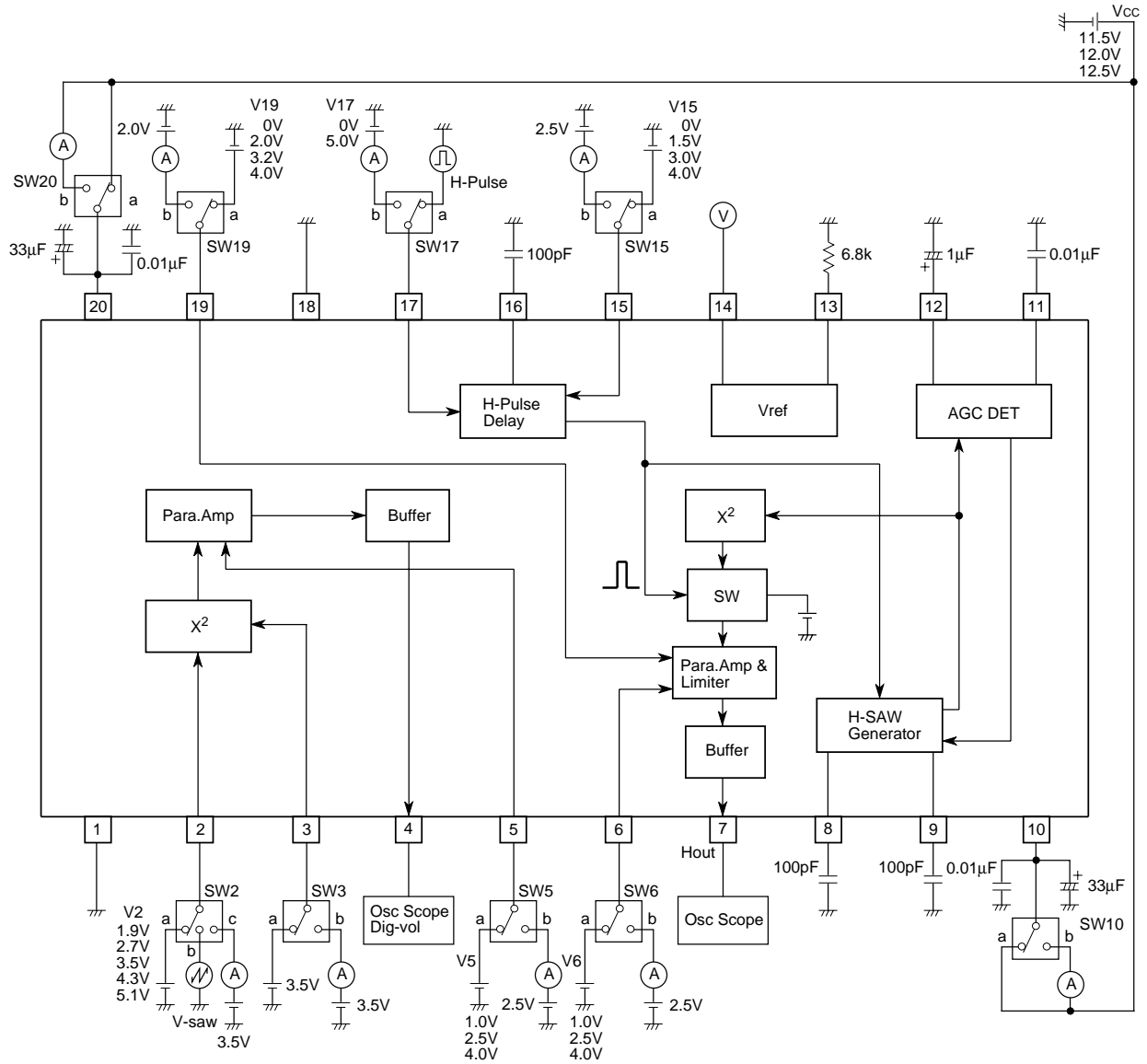

Units Resistance : Ω
Capacitance : F

TYPICAL CHARACTERISTICS

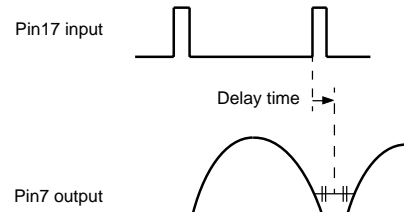
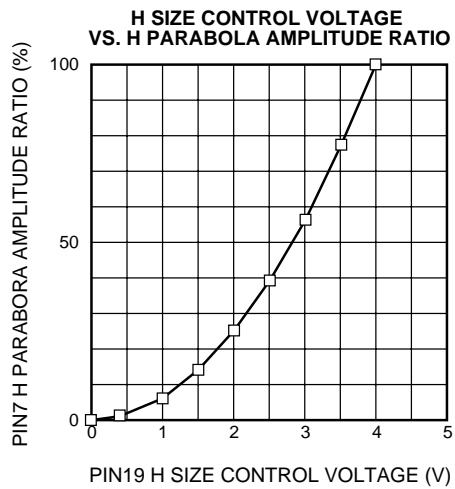
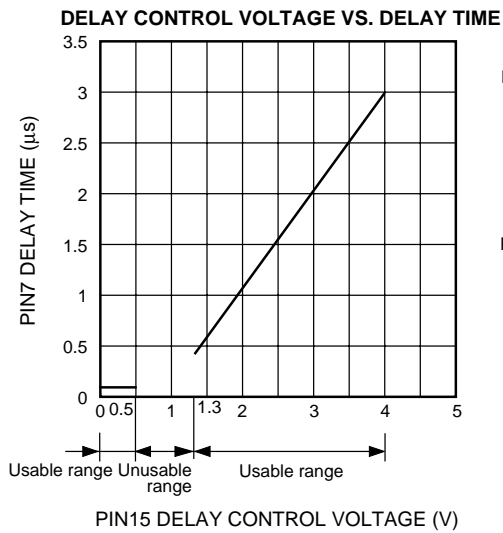
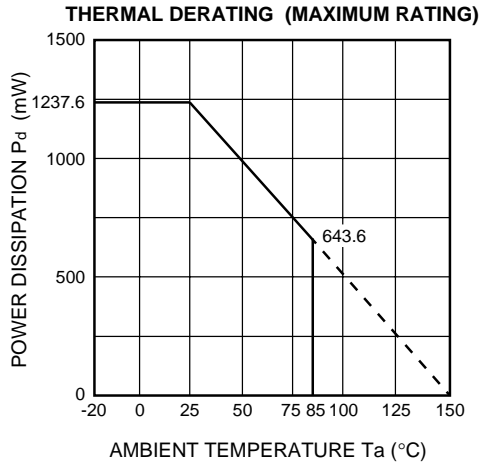

Pin6=2.5V const.

$$\text{Amplitude ratio} = \frac{\text{Pin7 output level}}{\text{Pin7 output level at pin19=4.0V}} \times 100(\%)$$

H GAIN CONTROL VOLTAGE VS. H PARABOLA AMPLITUDE

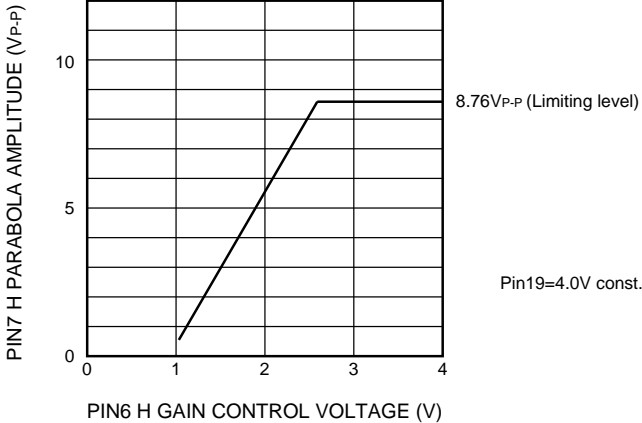

V PARA DC OUTPUT VOLTAGE RATIO

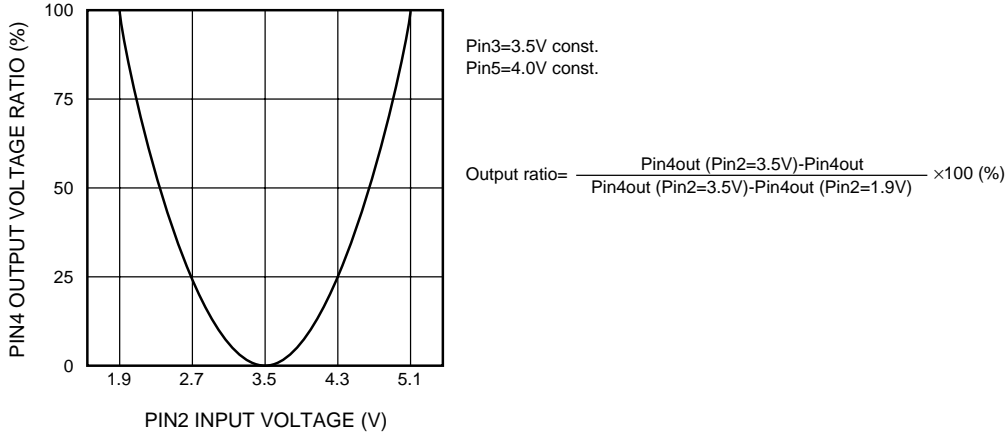

V PARA AMP GAIN CONTROL VOLTAGE VS. OUTPUT AMPLITUDE

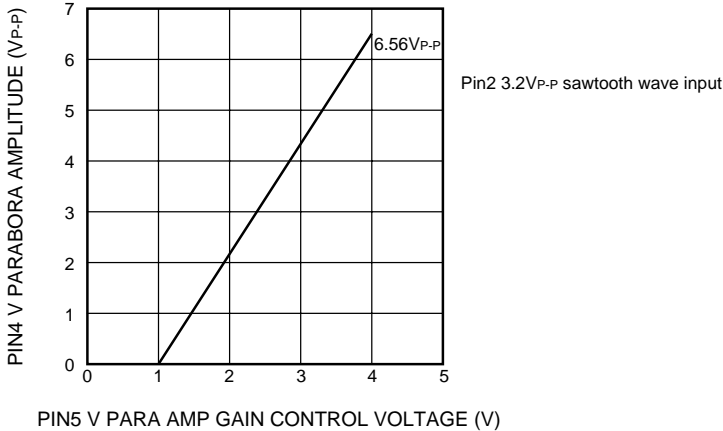

TIMING DIAGRAM

HORIZONTAL BLOCK

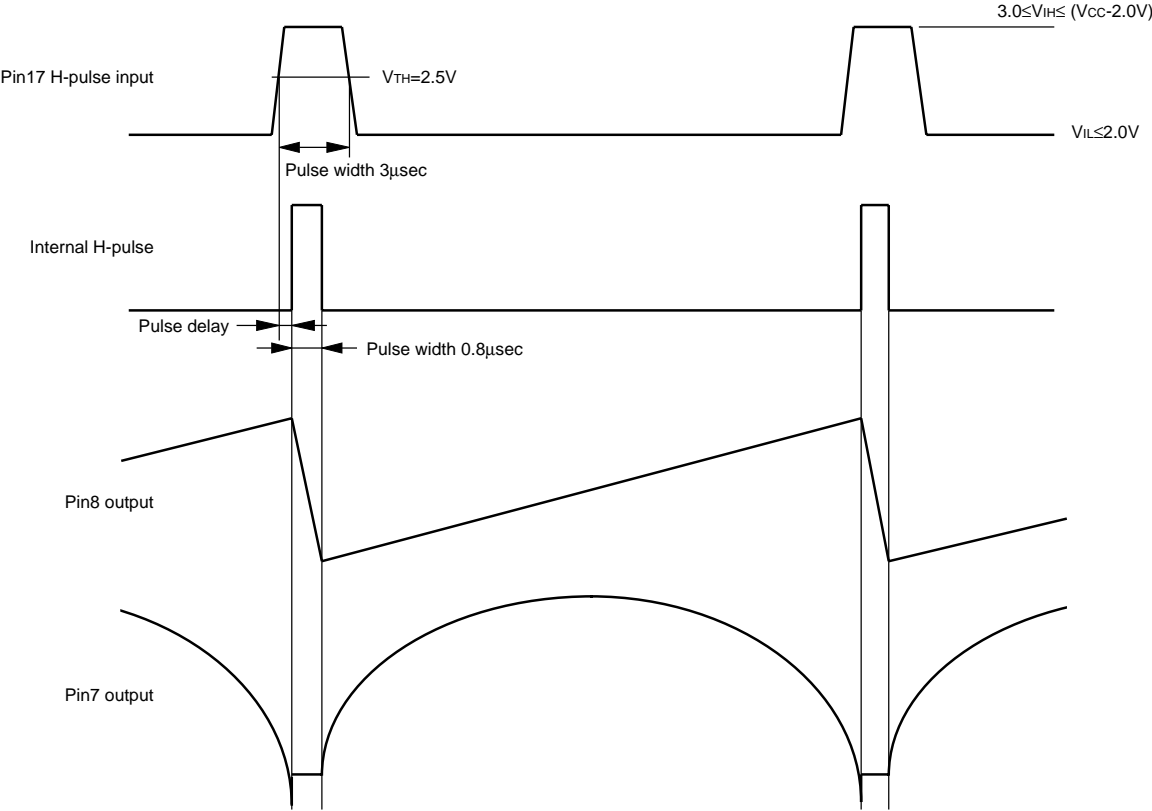

VERTICAL BLOCK

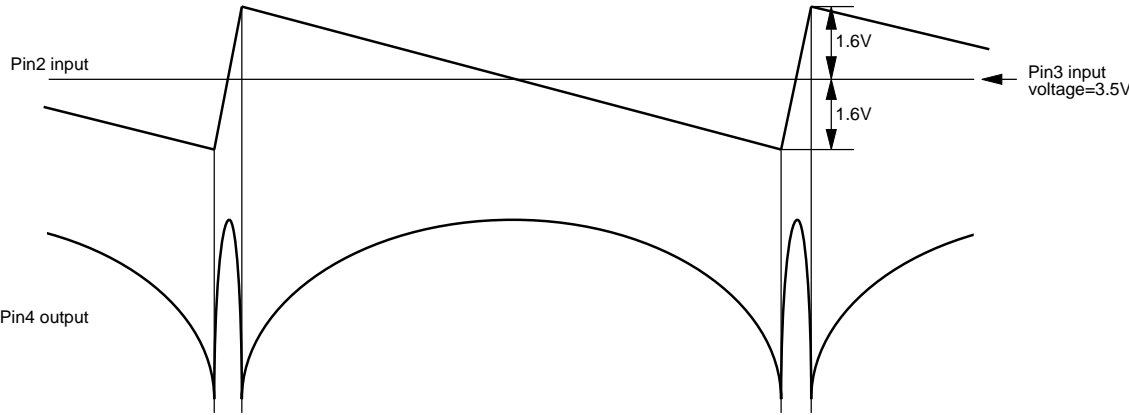

APPLICATION EXAMPLE

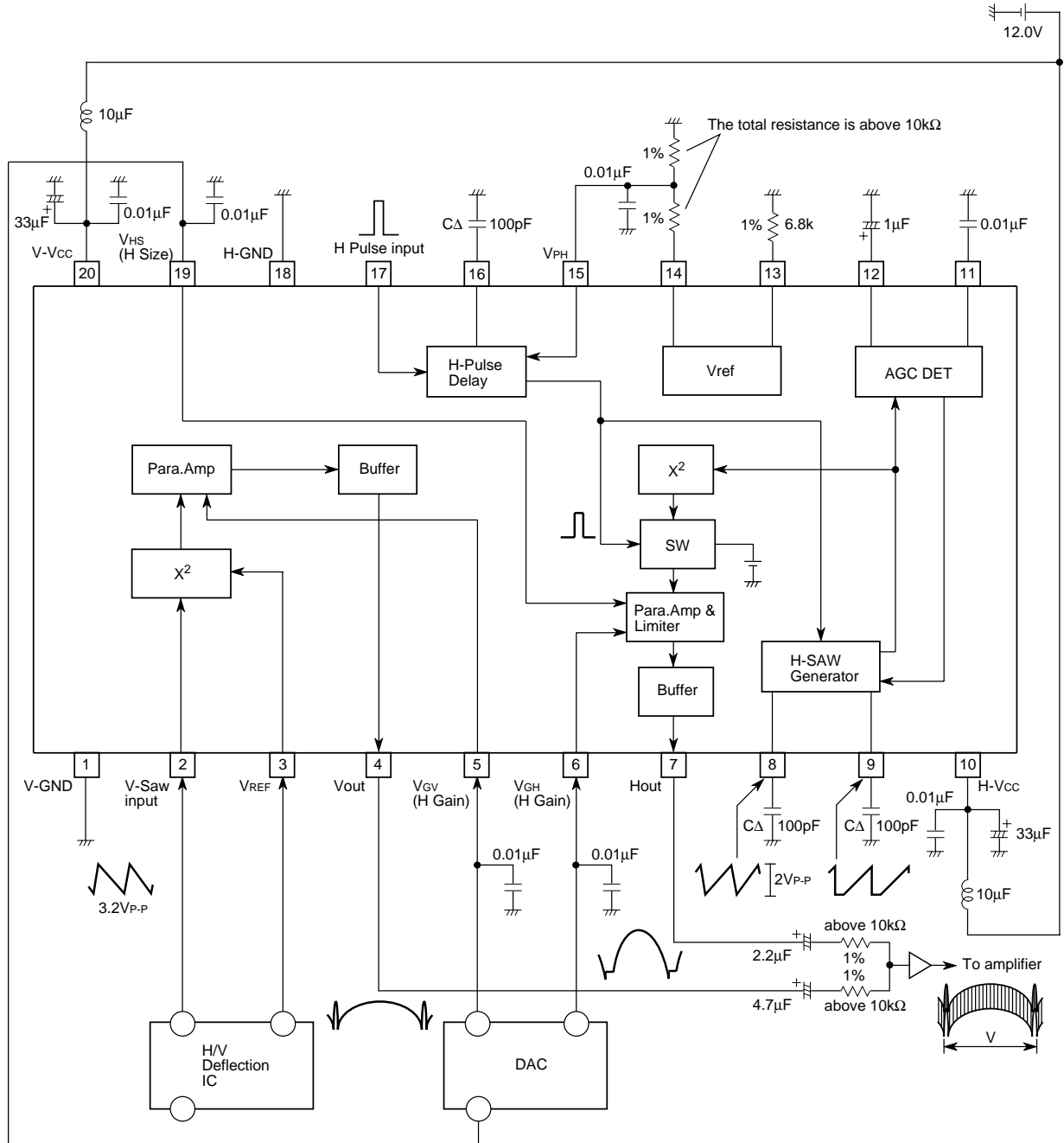

Units Resistance : Ω
Capacitance : F

DESCRIPTION OF PIN

Pin No.	Name	DC voltage (V)	Peripheral circuit of pins	Description of function
1	V-GND	-		GND of vertical block
2	Vsawi	3.5V		<p>Vertical sawtooth wave input pin.</p>
3	Vsawref	3.5V		<p>Vertical reference voltage input pin. (3.5V)</p>
4	Vout	10V (Peak)		<p>Vertical parabola wave output pin.</p>
5	Vgv	1.0 to 4.0V		<p>Vertical parabola wave gain control voltage input pin. Input voltage range is 1.0 to 4.0V.</p>
6	VGH	1.0 to 4.0V		<p>Horizontal parabola wave gain control voltage input pin. Input voltage range is 1.0 to 4.0V.</p>

DESCRIPTION OF PIN (cont.)

Pin No.	Name	DC voltage (V)	Peripheral circuit of pins	Description of function
7	Hout	9.2V (Peak)		horizontal parabola wave output pin. Peak voltage=9.2V (fixed) Amplitude is possible to control by pin6 and pin19.
8	Cret	7.1V (Top) 4.9V (Bottom)		Connection pin of horizontal retrace capacitor. Recommended capacitance is 100pF.
9	Ctrc	7.1V (Top) 4.9V (Bottom)		Connection pin of horizontal trace capacitor. Recommended capacitance is 100pF.
10	H-Vcc	12.0V		Vcc of horizontal block.
11	CAGCr	2.5V		Connection pin of horizontal sawtooth wave AGC retrace capacitor. Recommended capacitance is 0.01μF.

DESCRIPTION OF PIN (cont.)

Pin No.	Name	DC voltage (V)	Peripheral circuit of pins	Description of function
12	CAGC	4.0V		<p>Connection pin of horizontal AGC capacitor. Recommended capacitance is 1μF.</p>
13	VREFR	1.28V		<p>Connection pin of reference current source resistor. Recommended resistance is 6.8kΩ.</p>
14	VREFO	7.0V		<p>Reference voltage output for horizontal pulse delay circuit. Should be connect more than 10kΩ external resistor.</p>
15	VPH	0 to 0.5V 1.3 to 4.0V		<p>Delay adjustment voltage input pin of horizontal pulse. Input voltage range is 1.3 to 4.0V. At 0 to 0.5V, delay is minimized. (0.5 to 1.3V is unusable range.)</p>
16	Chpd	0V (Bottom)		<p>Connection pin of horizontal pulse delay timing capacitor. Recommended capacitance is 100pF.</p>

DESCRIPTION OF PIN (cont.)

Pin No.	Name	DC voltage (V)	Peripheral circuit of pins	Description of function
17	HPin	-		Horizontal pulse input pin. Low input level is less than 2.0V, and high is 3.0 to 10V (at Vcc=12V).
18	H-GND	-		GND of horizontal block
19	VHs	-		Horizontal size control voltage input pin. Input Voltage range is 0 to 4V.
20	V-Vcc	12.0V		Vcc of vertical block