

M52734SP

3-CHANNEL VIDEO AMPLIFICATION WITH OSD BLANKING

DESCRIPTION

The M52734SP is a semiconductor integrated circuit amplifies video signals, having a 3-channel amplifier with a band width of 130MHz. The circuit also features the OSD mixing function.

The circuit is most useful with high resolution displays that have OSD, and its function are available for each channel, including OSD blanking, OSD mixing, wide-band amplification, contrast control (main and sub), and brightness control.

FEATURES

- Frequency band width: RGB.....130MHz (3VP-P)
OSD.....50MHz
- Input :RGB.....0.7VP-P (typ.)
OSD.....3.0VP-P min. (positive)
BLK3.0VP-P min. (positive)
- Output :RGB.....4.0VP-P (max.)
OSD.....4.0VP-P (max.)
- To adjust contrast, two types of controls are provided, main and sub. With the main control, the contrast of the 3-channels can be changed simultaneously. Sub controls are used to adjust the contrast of a given channel individually. The control terminals can be controlled by applying a voltage of 0 to 5V.
- The DC power remains stable at the IC output terminal because a feedback circuit is built in.

APPLICATION

Display monitor

RECOMMENDED OPERATING CONDITION

Supply voltage range.....11.5 to 12.5V
Rated supply voltage.....12.0V

PIN CONFIGURATION (TOP VIEW)

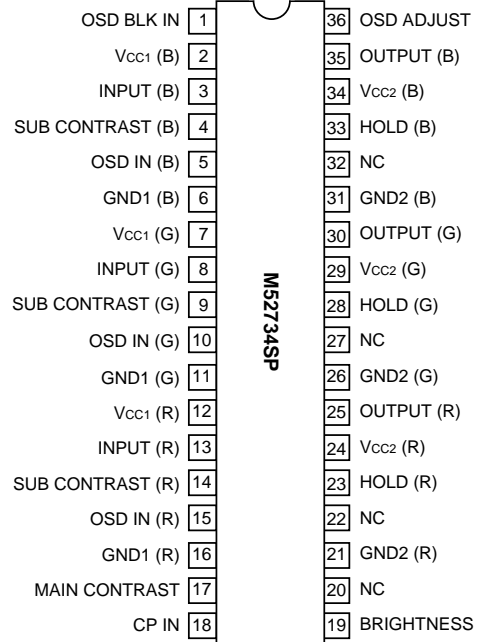

Outline 36P4E

NC : NO CONNECTION

BLOCK DIAGRAM

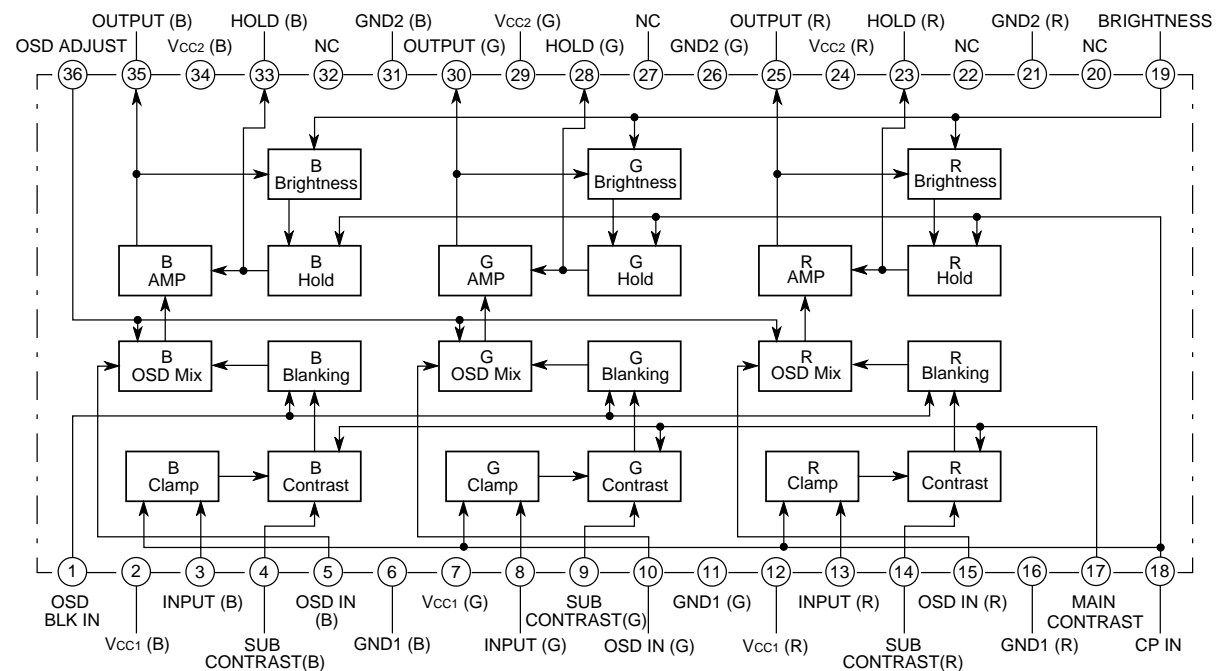

3-CHANNEL VIDEO AMPLIFICATION WITH OSD BLANKING

ABSOLUTE MAXIMUM RATINGS (Ta=25°C)

Symbol	Parameter	Ratings	Unit
Vcc	Supply voltage	13.0	V
Pd	Power dissipation	2016	mW
Topr	Ambient temperature	-20 to +85	°C
Tstg	Storage temperature	-40 to +150	°C
Vopr	Recommended supply voltage	12.0	V
Vopr'	Recommended supply voltage range	11.5 to 12.5	V
Surge	Electrostatic discharge	±200	V

ELECTRICAL CHARACTERISTICS (Vcc=12V, Ta=25°C, unless otherwise noted)

Symbol	Parameter	Test conditions										Limits			Unit
		Test point (s)	Input			External power supply (V)				Pulse input		Min.	Typ.	Max.	
			SW13 R-ch	SW8 G-ch	SW3 B-ch	V4	V17	V19	V36	SW18	SW1 5, 10, 15				
Icc	Circuit current	A	a	a	a	5	5	5	2	b SG5	a	70	100	140	mA
Vomax	Output dynamic range	T.P.35 T.P.30 T.P.25	b SG6	b SG6	b SG6	5	5	Variable	5	b SG5	a	5.8	6.8	9.0	VP-P
Vimax	Maximum input	T.P.35 T.P.30 T.P.25	b SG6	b SG6	b SG6	5	2.5	1	5	b SG5	a	1	1.8	-	VP-P
Gv	Maximum gain	T.P.35 T.P.30 T.P.25	b SG6	b SG6	b SG6	5	5	2	5	b SG5	a	15	17	20	dB
ΔGv	Relative maximum gain		Relative to measured values above									0.8	1	1.2	-
VCR1	Contrast control characteristics (typical)	T.P.35 T.P.30 T.P.25	b SG6	b SG6	b SG6	5	4	2	5	b SG5	a	14	15.5	17	dB
ΔVCR1	Contrast control relative characteristics (typical)		Relative to measured values above									0.8	1	1.2	-
VCR2	Contrast control characteristics (minimum)	T.P.35 T.P.30 T.P.25	b SG6	b SG6	b SG6	5	1	2	5	b SG5	a	0.3	0.6	0.9	VP-P
ΔVCR2	Contrast control relative characteristics (minimum)		Relative to measured values above									0.8	1	1.2	-
VSCR1	Sub contrast control characteristics (typical)	T.P.35 T.P.30 T.P.25	b SG6	b SG6	b SG6	4	5	2	5	b SG5	a	14	15.5	17	dB
ΔVSCR1	Sub contrast control relative characteristics (typical)		Relative to measured values above									0.8	1	1.2	-
VSCR2	Sub contrast control characteristics (minimum)	T.P.35 T.P.30 T.P.25	b SG6	b SG6	b SG6	1	5	2	5	b SG5	a	0.5	0.9	1.3	VP-P
ΔVSCR2	Sub contrast control relative characteristics (minimum)		Relative to measured values above									0.8	1	1.2	-
VSCR3	Contrast/sub contrast control characteristics (typical)	T.P.35 T.P.30 T.P.25	b SG6	b SG6	b SG6	3	3	2	5	b SG5	a	0.8	1.5	2.2	VP-P
ΔVSCR3	Contrast/sub contrast control relative characteristics (typical)		Relative to measured values above									0.8	1	1.2	-
VB1	Brightness control characteristics (maximum)	T.P.35 T.P.30 T.P.25	a	a	a	5	5	4	5	b SG5	a	3.0	3.6	4.2	V
ΔVB1	Brightness control relative characteristics (maximum)		Relative to measured values above									-0.3	0	0.3	V

3-CHANNEL VIDEO AMPLIFICATION WITH OSD BLANKING

ELECTRICAL CHARACTERISTICS (cont.)

Symbol	Parameter	Test point (s)	Test conditions									Limits			Unit
			Input			External power supply (V)				Pulse input		Min.	Typ.	Max.	
			SW13 R-ch	SW8 G-ch	SW3 B-ch	V4	V17	V19	V36	SW18	SW15, 10, 15				
V _{B2}	Brightness control characteristics (typical)	T.P.35 T.P.30 T.P.25	a -	a -	a -	5	5	2.5	5	b SG5	a -	1.7	2.3	2.9	V
ΔV _{B2}	Brightness control relative characteristics (typical)		Relative to measured values above									-0.3	0	0.3	V
V _{B3}	Brightness control characteristics (minimum)	T.P.35 T.P.30 T.P.25	a -	a -	a -	5	5	1	5	b SG5	a -	0.5	0.9	1.3	V
ΔV _{B3}	Brightness control relative characteristics (minimum)		Relative to measured values above									-0.3	0	0.3	V
F _{C1}	Frequency characteristics 1 (f=50MHz; maximum)	T.P.35 T.P.30 T.P.25	b SG2	b SG2	b SG2	5	2.5	V _T	-	a -	a -	-2.5	-1	3	dB
ΔF _{C1}	Frequency relative characteristics 1 (f=50MHz; maximum)		Relative to measured values above									-1	0	1	dB
F _{C1'}	Frequency characteristics 1 (f=130MHz; maximum)	T.P.35 T.P.30 T.P.25	b SG3	b SG3	b SG3	5	2.5	V _T	-	a -	a -	-3	-2	3	dB
ΔF _{C1'}	Frequency relative characteristics 1 (f=130MHz; maximum)		Relative to measured values above									-1	0	1	dB
F _{C2}	Frequency characteristics 2 (f=50MHz; maximum)	T.P.35 T.P.30 T.P.25	b SG2	b SG2	b SG2	5	1.5	V _T	-	a -	a -	-3	0	3	dB
ΔF _{C2'}	Frequency relative characteristics 2 (f=130MHz; maximum)	T.P.35 T.P.30 T.P.25	b SG3	b SG3	b SG3	5	1.5	V _T	-	a -	a -	-1	0	1	dB
C.T.1	Crosstalk 1 (f=50MHz)	T.P.35 T.P.30 T.P.25	b SG2	a -	a -	5	5	V _T	-	a -	a -	-	-30	-20	dB
C.T.1'	Crosstalk 1 (f=130MHz)	T.P.35 T.P.30 T.P.25	b SG3	a -	a -	5	5	V _T	-	a -	a -	-	-20	-15	dB
C.T.2	Crosstalk 2 (f=50MHz)	T.P.35 T.P.30 T.P.25	a -	b SG2	a -	5	5	V _T	-	a -	a -	-	-30	-20	dB
C.T.2'	Crosstalk 2 (f=130MHz)	T.P.35 T.P.30 T.P.25	a -	b SG3	a -	5	5	V _T	-	a -	a -	-	-20	-15	dB
C.T.3	Crosstalk 3 (f=50MHz)	T.P.35 T.P.30 T.P.25	a -	a -	b SG2	5	5	V _T	-	a -	a -	-	-30	-20	dB
C.T.3'	Crosstalk 3 (f=130MHz)	T.P.35 T.P.30 T.P.25	a -	a -	b SG3	5	5	V _T	-	a -	a -	-	-20	-15	dB
Tr	Pulse characteristics 1	T.P.35 T.P.30 T.P.25	b SG4	b SG4	b SG4	5	3.3	2	-	b SG5	a -	-	3	7	nsec
Tf	Pulse characteristics 2	T.P.35 T.P.30 T.P.25	b SG4	b SG4	b SG4	5	3.3	2	-	b SG5	a -	-	4	8	nsec
V _{14th}	Clamp pulse threshold voltage	T.P.35 T.P.30 T.P.25	a -	a -	a -	5	5	2	-	b SG5	a -	1.0	1.5	2.0	V _{DC}
W ₁₄	Clamp pulse minimum width	T.P.35 T.P.30 T.P.25	a -	a -	a -	5	5	2	-	b SG5	a -	-	0.1	0.5	μsec
P _{DCH}	Pedestal voltage temperatere characteristics1	T.P.35 T.P.30 T.P.25	b SG6	b SG6	b SG6	5	5	2	-	b SG5	a -	-0.3	0	0.3	V _{DC}

3-CHANNEL VIDEO AMPLIFICATION WITH OSD BLANKING

ELECTRICAL CHARACTERISTICS (cont.)

Symbol	Parameter	Test point (s)	Test conditions									Limits			Unit
			Input			External power supply (V)				Pulse input		Min.	Typ.	Max.	
			SW13 R-ch	SW8 G-ch	SW3 B-ch	V4	V17	V19	V36	SW18	SW1 5, 10, 15				
PdCL	Pedestal voltage temperatere characteristics2	T.P.35 T.P.30 T.P.25	b SG6	b SG6	b SG6	5	5	2	-	b SG5	a -	-0.3	0	0.3	Vdc
OTr	OSD pulse characteristics1	T.P.35 T.P.30 T.P.25	a -	a -	a -	5	5	2	3	a -	b SG7	-	4	8	nsec
OTf	OSD pulse characteristics2	T.P.35 T.P.30 T.P.25	a -	a -	a -	5	5	2	3	a -	b SG7	-	4	8	nsec
Oaj1	OSD adjusting control characteristics (maximum)	T.P.35 T.P.30 T.P.25	a -	a -	a -	5	5	2	4	a -	b SG7	3.5	4.0	4.5	VP-P
ΔOaj1	OSD adjusting control relative characteristics (maximum)		Relative to measured values above									0.8	1	1.2	-
Oaj2	OSD adjusting control characteristics (minimum)	T.P.35 T.P.30 T.P.25	a -	a -	a -	5	5	2	0	a -	b SG7	-	0	0.5	VP-P
ΔOaj2	OSD adjusting control relative characteristics (minimum)		Relative to measured values above									0.8	1	1.2	-
OSDth	OSD input threshold voltage	T.P.35 T.P.30 T.P.25	a -	a -	a -	5	5	2	5	a -	b SG7	1.7	2.5	3.5	VDC
V1th	BLK input threshold voltage	T.P.35 T.P.30 T.P.25	b SG6	b SG6	b SG6	5	5	2	5	a -	SW1 only b SG7	1.7	2.5	3.5	VDC

ELECTRICAL CHARACTERISTICS TEST METHOD

1. Because a description of signal input pin and pulse input pin switch numbers is already given in Supplementary Table, only external power supply switch numbers are included in the notes below.

Sub contrast voltages V4, V9 and V14 are always set to the same voltage, therefore only V4 is referred to in Supplementary Table.

Icc Circuit current

Measuring conditions are as listed in Supplementary Table.
Measured with an ammeter At test point A when SW1 is set to a.

Vomax Output dynamic range

Voltage V19 is varied as described below:

- Increase V19 gradually while inputting SG6 to pin 13 (8 or 3). Measure the voltage when the top of the waveform output at T.P.25 (30 or 35) is distorted. The voltage is called VTR1 (VTG1 or VTB1). Next, decrease V19 gradually, and measure the voltage when the bottom of the waveform output at T.P.35 (30 or 25) is distorted. The voltage is called VTR2 (VTG2 or VTB2).

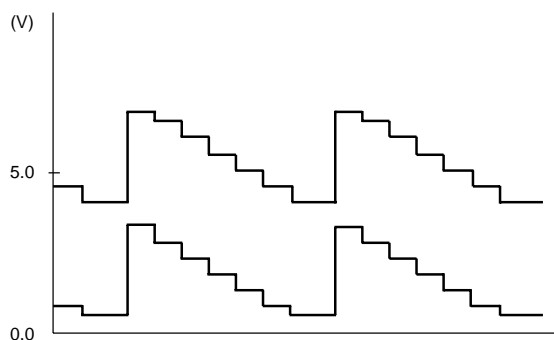

Waveform Output at T.P.25
(Identical to output at T.P.30 and T.P.35.)

- Voltage VT (VTR, VTG and VTB) is calculated by the equation below:

$$VTR (VTG, VTB) = \frac{VTR1 (VTG1, VTB1) + VTR2 (VTG1, VTB1)}{2}$$

Use relevant voltages, depending on the pin at which the waveform is output; specifically, use VTR1 when it is output at T.P.25; VTG1, at T.P.30, and VTB, at T.P.35.

3-CHANNEL VIDEO AMPLIFICATION WITH OSD BLANKING

- After setting V_{TR} (V_{TG} or V_{TB}), increase the SG6 amplitude gradually, starting from 700mV. Measure the amplitude when the top and bottom of the waveform output at T.P25 (30 or starts becoming distorted synchronously.

Vimax Maximum input

Measuring conditions are the same as those used above, except that the setting of V17 is changed to 2.5V as specified in Supplementary Table. Increase the input signal amplitude gradually, starting from 700mV_{P-P}. Measure the amplitude when the output signal starts becoming distorted.

Gv Maximum gain

ΔGv Relative maximum gain

- Input SG6 to pin 13 (8 or 3), and read the amplitude at output T.P25 (30 or 35). The amplitude is called V_{OR1} (V_{OG1} or V_{OB1}).
- Maximum gain G_V is calculated by the equation below:

$$G_V = 20 \text{LOG} \frac{V_{OR1} (V_{OG1}, V_{OB1})}{0.7} \frac{[V_{P-P}]}{[V_{P-P}]}$$

- Relative maximum gain ΔG is calculated by the equation below:

$$\Delta G_V = V_{OR1}/V_{OG1}, V_{OG1}/V_{OB1}, V_{OB1}/V_{OR1}$$

V_{CR1} Contrast control characteristics (typical)

ΔV_{CR1} Contrast control relative characteristics (typical)

- Measuring conditions are as given in Supplementary Table. The setting of V17 is changed to 4V.
- Measure the amplitude output at T.P25 (30 or 35). The measured value is called V_{OR2} (V_{OG2} or V_{OB2}).
- Contrast control characteristics V_{CR1} and relative characteristics ΔV_{CR1} are calculated, respectively, by the equations below:

$$V_{CR1} = 20 \text{LOG} \frac{V_{OR2} (V_{OG2}, V_{OB2})}{0.7} \frac{[V_{P-P}]}{[V_{P-P}]}$$

$$\Delta V_{CR1} = V_{OR2}/V_{OG2}, V_{OG2}/V_{OB2}, V_{OB2}/V_{OR1}$$

V_{CR2} Contrast control characteristics (minimum)

ΔV_{CR2} Contrast control relative characteristics (minimum)

- Measuring conditions are as given in Supplementary Table. The setting of V17 is changed to 1.0V.
- Measure the amplitude output at T.P25 (30 or 35). The measured value is called V_{OR3} (V_{OG3} or V_{OB3}), and is treated as V_{CR2} .
- Contrast control relative characteristics ΔV_{CR2} are calculated by the equation below:

$$\Delta V_{CR2} = V_{OR3}/V_{OG3}, V_{OG3}/V_{OB3}, V_{OB3}/V_{OR3}$$

V_{SCR1} Sub contrast control characteristics (typical)

ΔV_{SCR1} Sub contrast control relative characteristics (typical)

- Set V4, V9 and V14 to 4.0V. Other conditions are as given in Supplementary Table.
- Measure the amplitude output at T.P25 (30 or 35). The measured value is called V_{OR4} (V_{OG4} or V_{OB4}).
- Sub contrast control characteristics V_{SCR1} and relative characteristics ΔV_{SCR1} are calculated, respectively, by the equations below:

$$V_{SCR1} = 20 \text{LOG} \frac{V_{OR4} (V_{OG4}, V_{OB4})}{0.7} \frac{[V_{P-P}]}{[V_{P-P}]}$$

$$\Delta V_{SCR1} = V_{OR4}/V_{OG4}, V_{OG4}/V_{OB4}, V_{OB4}/V_{OR4}$$

V_{SCR2} Sub contrast control characteristics (minimum)

ΔV_{SCR2} Sub contrast control relative characteristics (minimum)

- Set V4, V9 and V14 to 1.0V. Other conditions are as given in Supplementary Table.
- Measure the amplitude output at T.P25 (30 or 35). The measured value is called V_{OR5} (V_{OG5} or V_{OB5}).
- Relative characteristics ΔV_{SCR2} are calculated by the equation below:

$$\Delta V_{SCR2} = V_{OR5}/V_{OG5}, V_{OG5}/V_{OB5}, V_{OB5}/V_{OR5}$$

V_{CR3} Contrast/sub contrast control characteristics (typical)

ΔV_{CR3} Contrast/sub contrast control relative characteristics (typical)

- Set V4, V9, V14 and V17 to 3.0V. Other conditions are as given in Supplementary Table.
- Measure the amplitude at T.P25 (30 or 35). The measured value is called V_{OR6} (V_{OG6} or V_{OB6}).

$$V_{CR3} = 20 \text{LOG} \frac{V_{OR6} (V_{OG6}, V_{OB6})}{0.7} \frac{[V_{P-P}]}{[V_{P-P}]}$$

$$\Delta V_{CR3} = V_{OR6}/V_{OG6}, V_{OG6}/V_{OB6}, V_{OB6}/V_{OR6}$$

V_{B1} Brightness control characteristics (maximum)

ΔV_{B1} Brightness control relative characteristics (maximum)

- Measuring conditions are as given in Supplementary Table.
- Measure the output at T.P25 (30 or 35) with a voltmeter. The measured value is called V_{OR7} (V_{OG7} or V_{OB7}), and is treated as V_{B1} .
- To obtain brightness control relative characteristics, calculate the difference in the output between the channels, using V_{OR7} , V_{OG7} and V_{OB7} .

$$\Delta V_{B1} = V_{OR7} - V_{OG7} \quad [\text{mV}]$$

$$= V_{OG7} - V_{OB7}$$

$$= V_{OB7} - V_{OR7}$$

3-CHANNEL VIDEO AMPLIFICATION WITH OSD BLANKING

V_{B2} Brightness control characteristics (typical)

ΔV_{B2} Brightness control relative characteristics (typical)

1. Measuring conditions are as given in Supplementary Table.
2. Measure the output at T.P25 (30 or 35) with a voltmeter.
The measured value is called V_{OR7} (V_{OG7} or V_{OB7}), and is treated as V_{B2}.
3. To obtain brightness control relative characteristics (ΔV_{B2}), calculate the difference in the output between the channels, using V_{OR7}, V_{OG7}, and V_{OB7}.

$$\begin{aligned} \Delta V_{B2} &= V_{OR7} - V_{OG7} && [mV] \\ &= V_{OG7} - V_{OB7} \\ &= V_{OB7} - V_{OR7} \end{aligned}$$

V_{B3} Brightness control characteristics (minimum)

ΔV_{B3} Brightness control relative characteristics (minimum)

1. Measuring conditions are as given in Supplementary Table.
2. Measure the output at T.P25 (30 or 35) with a voltmeter.
The measured value is called V_{OR7'} (V_{OG7'} or V_{OB7'}), and is treated as V_{B2}.
3. To obtain brightness control relative characteristics (ΔV_{B3}), calculate the difference in the output between the channels, using V_{OR7'}, V_{OG7'} and V_{OB7'}.

$$\begin{aligned} \Delta V_{B3} &= V_{OR7'} - V_{OG7'} && [mV] \\ &= V_{OG7'} - V_{OB7'} \\ &= V_{OB7'} - V_{OR7'} \end{aligned}$$

F_{C1} Frequency characteristics1 (f=50MHz; maximum)

ΔF_{C1} Frequency relative characteristics1

(f=50MHz; maximum)

F_{C1'} Frequency characteristics1 (f=130MHz; maximum)

ΔF_{C1'} Frequency relative characteristics1

(f=130MHz; maximum)

1. Measuring conditions are as given in Supplementary Table.
2. SG1-SG2 and SG3 are input. The amplitude of the waveform output at T.P25 (30 or 35) is measured.
3. Supposing that the measured value is treated as amplitude V_{OR1} (V_{OG1} or V_{OB1}) when SG1 is input, as V_{OR8} (V_{OG8} or V_{OB8}) when SG2 is input, or as V_{OR9} (V_{OG9} or V_{OB9}) when SG3 is input, frequency characteristics F_{C1} and F_{C1'} are calculated as follows:

$$F_{C1} = 20 \text{LOG} \frac{V_{OR8} (V_{OG8}, V_{OB8})}{V_{OR1} (V_{OG1}, V_{OB1})} \frac{[V_{P-P}]}{[V_{P-P}]}$$

$$F_{C1'} = 20 \text{LOG} \frac{V_{OR9} (V_{OG9}, V_{OB9})}{V_{OR1} (V_{OG1}, V_{OB1})} \frac{[V_{P-P}]}{[V_{P-P}]}$$

4. Frequency relative band widths ΔF_{C1} and ΔF_{C1'} are equal to the difference in F_{C1} and F_{C1'}, respectively, between the channels.

F_{C2} Frequency characteristics2 (f=50MHz; maximum)

ΔF_{C2'} Frequency relative characteristics2

(f=130MHz; maximum)

Measuring conditions and procedure are the same as described in F_{C1}, ΔF_{C1}, F_{C1'}, ΔF_{C1'}, except that CONTRAST (V17) is turned down to 1.5V.

C.T.1 Crosstalk1 (f=50MHz)

C.T.1' Crosstalk1 (f=130MHz)

1. Measuring conditions are as given in Supplementary Table.
2. Input SG2 (or SG3) to pin 13 (R-ch) only, and then measure the waveform amplitude output at T.P25 (30 or 35). The measured value is called V_{OR}, V_{OG} and or V_{OB} respectively.
3. Crosstalk C.T. 1 is calculated by the equation below:

$$C.T.1 = 20 \text{LOG} \frac{V_{OR \text{ or } V_{OB}}}{V_{OR}} \frac{[V_{P-P}]}{[V_{P-P}]} \text{ [dB]} \\ (C.T.1')$$

C.T.2 Crosstalk2 (f=50MHz)

C.T.2' Crosstalk2 (f=130MHz)

1. Change the input pin from pin 13 (R-ch) to pin 8 (G-ch), and measure the output in the same way as in C.T.1, C.T.1'.
2. Crosstalk C.T. 2 is calculated by the equation below:

$$C.T.2 = 20 \text{LOG} \frac{V_{OR \text{ or } V_{OB}}}{V_{OG}} \frac{[V_{P-P}]}{[V_{P-P}]} \text{ [dB]} \\ (C.T.2')$$

C.T.3 Crosstalk3 (f=50MHz)

C.T.3' Crosstalk3 (f=130MHz)

1. Change the input pin from pin 13 (R-ch) to pin 3 (B-ch), and measure the output in the same way as in C.T.1, C.T.1'.
2. Crosstalk C.T. 3 is calculated by the equation below:

$$C.T.3 = 20 \text{LOG} \frac{V_{OR \text{ or } V_{OG}}}{V_{OB}} \frac{[V_{P-P}]}{[V_{P-P}]} \text{ [dB]} \\ (C.T.3')$$

3-CHANNEL VIDEO AMPLIFICATION WITH OSD BLANKING

Tr Pulse characteristics1**Tf Pulse characteristics2**

1. Measuring conditions are as given in Supplementary Table.
2. Measure the time needed for the input pulse to rise from 10% to 90% (Tr1) and to fall from 90% to 10% (Tf1) with an active prove.
3. Measure the time needed for the output pulse to rise from 10% to 90% (Tr2) and to fall from 90% to 10% (Tf2) with an active prove.
4. Pulse characteristics Tr and Tf are calculated by the equation below:

$$Tr \text{ (nsec)} = \sqrt{(Tr2)^2 - (Tr1)^2}$$

$$Tf \text{ (nsec)} = \sqrt{(Tf2)^2 - (Tf1)^2}$$

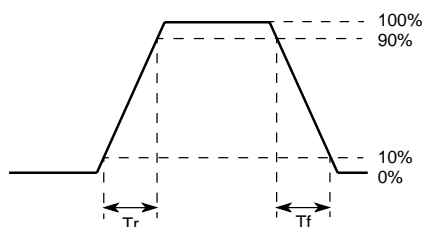
**V14th Clamp pulse threshold voltage**

1. Measuring conditions are as given in Supplementary Table.
2. Turn down the SG5 input level gradually, monitoring the output (about 2.0 VDC). Measure the SG5 input level when the output reaches 0V.

W14 Clamp pulse minimum width

Under the same conditions as given in Note 19, reduce the SG5 pulse width gradually, monitoring the output. Measure the SG5 pulse width when the output reaches 0V.

PdCH Pedestal voltage temperatere characteristics1**PdCL Pedestal voltage temperatere characteristics2**

1. Measuring conditions are as given in Supplementary Table.
2. Measure the pedestal voltage at room temperature.
The measured value is called PDC1.
3. Measure the pedestal voltage at temperatures of -20°C and 85°C. The measured value is called, respectively, PDC2 and PDC3.
4. $P_{DCH} = P_{DC1} - P_{DC2}$
 $P_{DCL} = P_{DC1} - P_{DC3}$

OTr OSD pulse characteristics1**OTf OSD pulse characteristics2**

1. Measuring conditions are as given in Supplementary Table.
2. Measure the time needed for the the output pulse to rise from 10% to 90% (OTr) and to fall from 90% to 10% (OTf) with an active prove.

Oaj1 OSD adjusting control characteristics (maximum)**ΔOaj1 OSD adjusting control relative characteristics (maximum)**

1. Measuring conditions are as given in Supplementary Table.
2. Measure the amplitude at T.P25 (30 or 35). The measured value is called VORA (VOGA or VOBA), and is treated as Oaj1.
3. OSD adjusting control relative characteristics ΔOaj1 are calculated by the equation below:

Oaj2 OSD adjusting control characteristics (minimum)**ΔOaj2 OSD adjusting control relative characteristics (minimum)**

1. Measuring conditions are as given in Supplementary Table, except that V36 is set to 0V.
2. Measure the amplitude at T.P25 (30 or 35). The measured value is called VORB (VOGB or VOBB), and is treated as Oaj2.
3. OSD adjusting control relative characteristics ΔOaj2 are calculated by the equation below:

OSDth OSD input threshold voltage

1. Measuring conditions are as given in Supplementary Table.
2. Reduce the SG7 input level gradually, monitoring output.
Measure the SG7 level when the output reaches 0V. The measured value is called OSDth.

V1th BLK input threshold voltage

1. Measuring conditions are as given in Supplementary Table.
2. Make sure that signals are not being output synchronously with SG7 (blanking period).
3. Reduce the SG7 input level gradually, monitoring output.
Measure the SG7 level when the blanking period disappears.
The measured value is called V1th.

3-CHANNEL VIDEO AMPLIFICATION WITH OSD BLANKING

INPUT SIGNAL

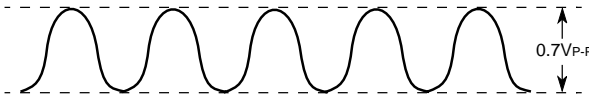
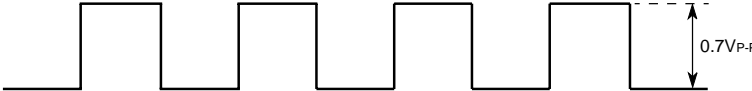
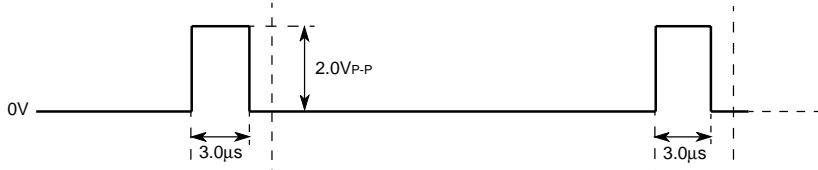
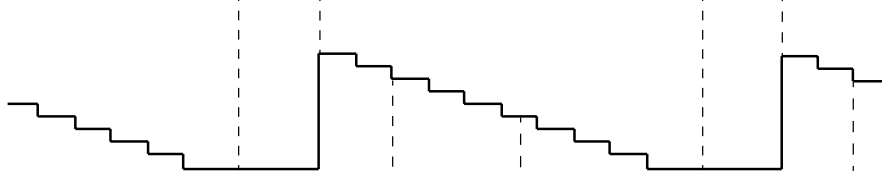
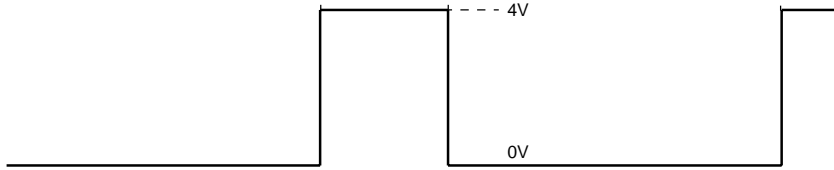
SG No.	Signals
SG1	Sine wave of amplitude 0.7V _{P-P} (f=1MHz) 
SG2	Sine wave with amplitude of 0.7V _{P-P} (f=50MHz)
SG3	Sine wave with amplitude of 0.7V _{P-P} (f=130MHz)
SG4	Pulse with amplitude of 0.7V _{P-P} (f=1MHz, duty=50%) Pulses which are synchronous with SG4 pedestal portion 
SG5	Pulses which are synchronous with standard video step waveform pedestal portion: amplitude, 2.0V _{P-P} ; and pulse width, 3.0μs (pulse width and amplitude sometimes variable) 
SG6 Standard video step waveform	 Video signal with amplitude of 0.7V _{P-P} (f=30kHz, amplitude sometimes variable)
SG7 OSD BLK and OSD signals	 Pulses which are synchronous with standard video step waveform's video portions: amplitude, 4.0V _{P-P} ; and pulse width, 25μs

M52734SP

3-CHANNEL VIDEO AMPLIFICATION WITH OSD BLANKING

TEST CIRCUIT

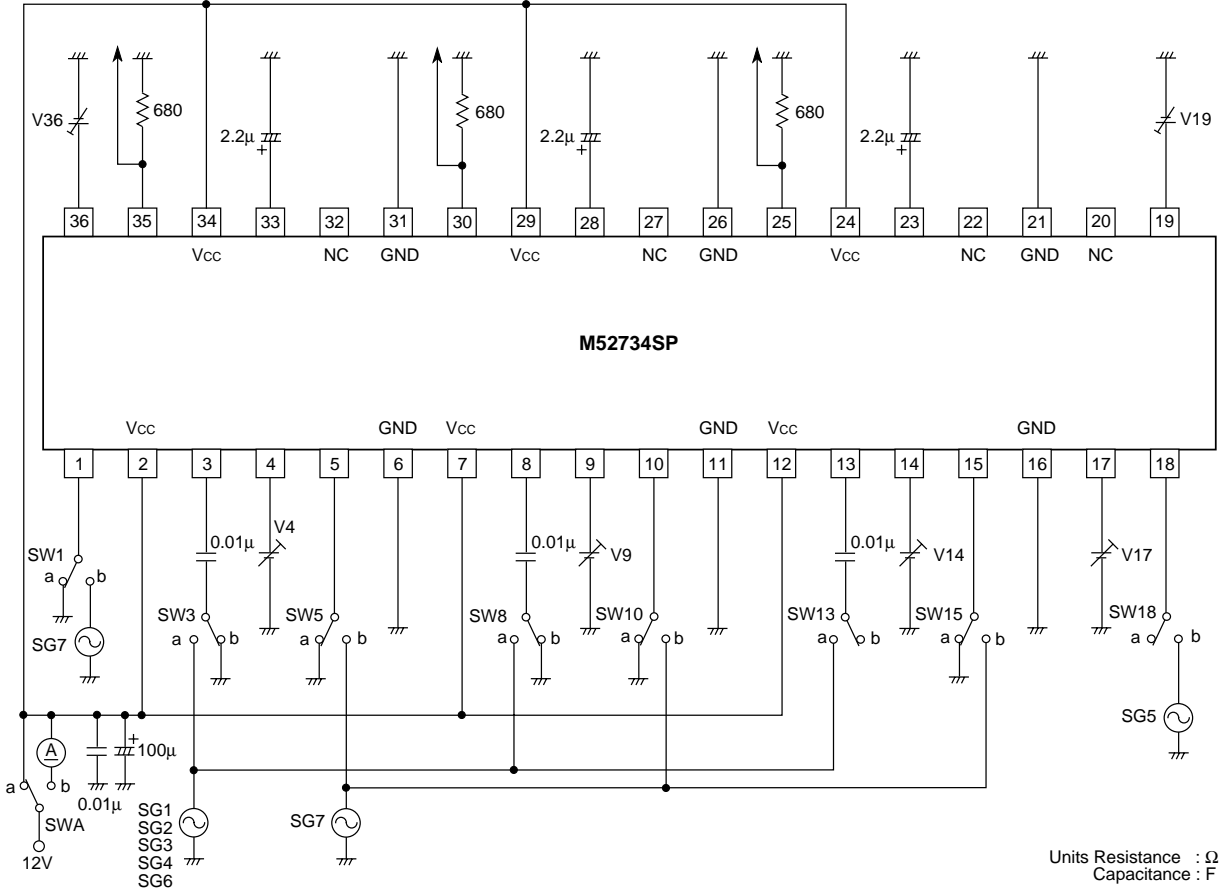

TYPICAL CHARACTERISTICS

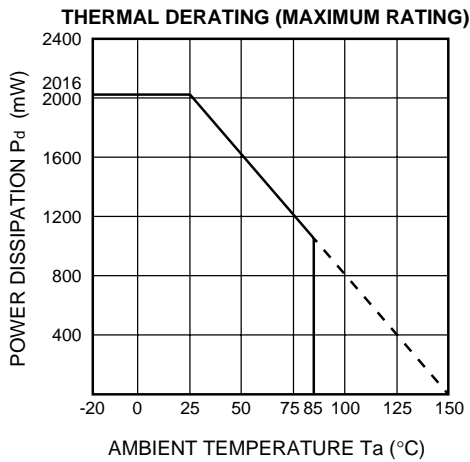

M52734SP

3-CHANNEL VIDEO AMPLIFICATION WITH OSD BLANKING

APPLICATION EXAMPLE

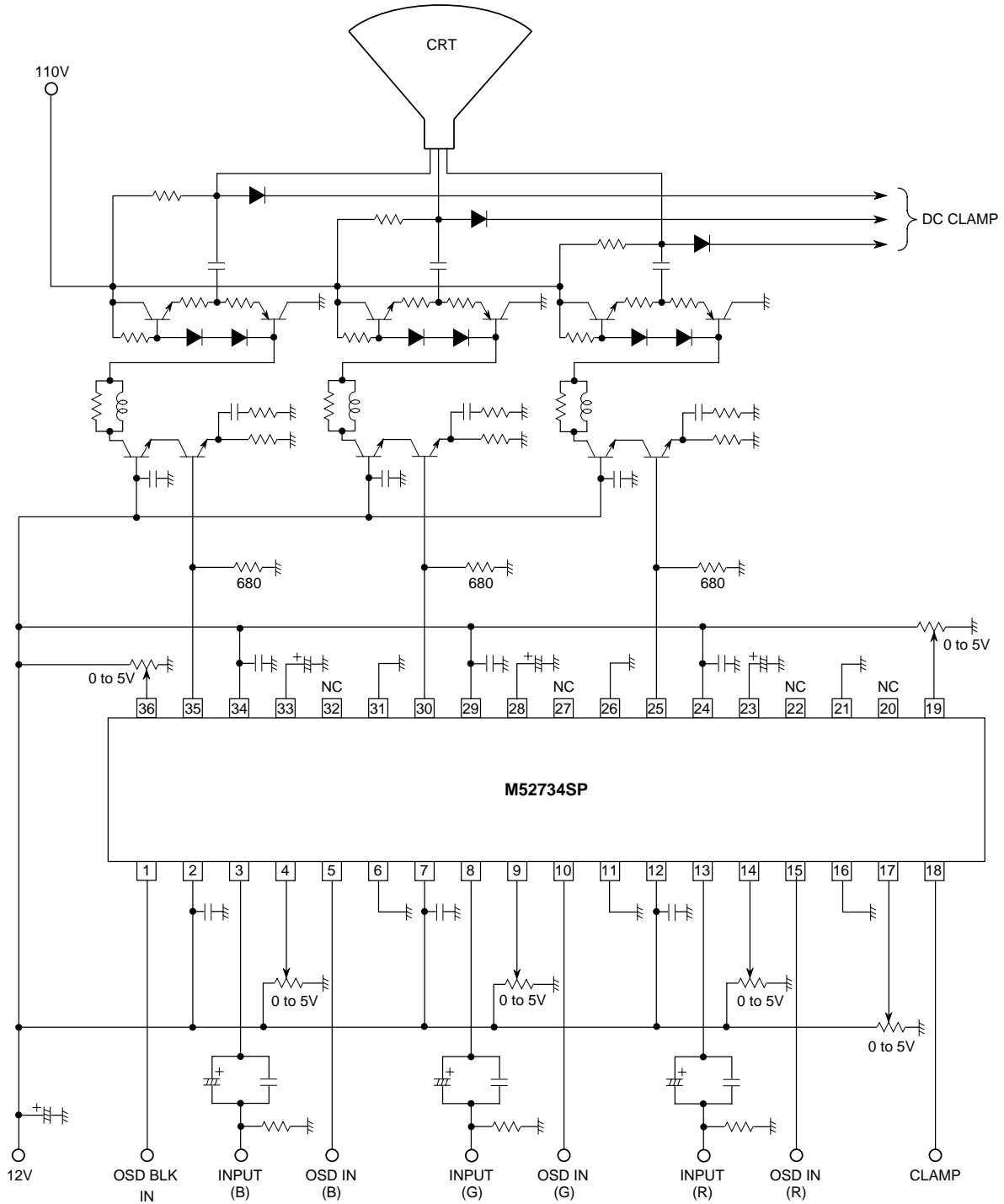

Units Resistance : Ω
Capacitance : F

3-CHANNEL VIDEO AMPLIFICATION WITH OSD BLANKING

DESCRIPTION OF PIN

Pin No.	Name	DC voltage (V)	Peripheral circuit of pins	Description of function
1	OSD BLK IN	-		<p>·Input pulses of minimum 3V.</p> <p>·Connected to GND if not used.</p>
2 7 12	Vcc (B-ch) Vcc (G-ch) Vcc (R-ch)	12	-	·Apply equivalent voltage to 3 channels.
3 8 13	INPUT (B) INPUT (G) INPUT (R)	2.5		<p>·Clamped to about 2.5V due to clamp pulses from pin 18.</p> <p>·Input at low impedance.</p>
4 9 14	Subcontrast (B) Subcontrast (G) Subcontrast (R)	2.5		·Use at maximum 5V for stable operation.
5 10 15	OSD IN (B) OSD IN (G) OSD IN (R)	-		<p>·Input pulses of minimum 3V.</p> <p>·Connected to GND if not used.</p>

3-CHANNEL VIDEO AMPLIFICATION WITH OSD BLANKING

DESCRIPTION OF PIN (cont.)

Pin No.	Name	DC voltage (V)	Peripheral circuit of pins	Description of function
6, 31 11, 26 16, 21	GND (B-ch) GND (G-ch) GND (R-ch)	GND	-	
17	Main contrast	2.5		·Use at maximum 5V for stable operation.
18	CP IN	-		·Input pulses of minimum 2.5V. ·Input at low impedance.
19	Brightness	-		
20, 22, 27, 32	NC	-	-	·Connected to GND usually; otherwise kept open.
23 28 33	Hold (R) Hold (G) Hold (B)	Variable		·A capacity is needed on the GND side.

M52734SP

3-CHANNEL VIDEO AMPLIFICATION WITH OSD BLANKING

DESCRIPTION OF PIN (cont.)

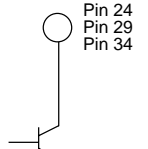
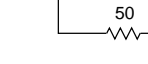
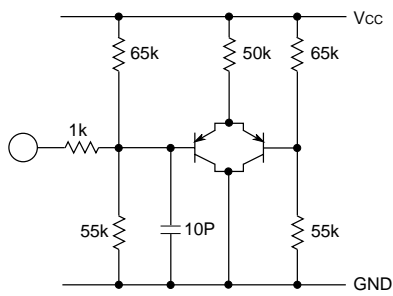
Pin No.	Name	DC voltage (V)	Peripheral circuit of pins	Description of function
24 29 34	Vcc2 (R) Vcc2 (G) Vcc2 (B)	Apply 12		<ul style="list-style-type: none"> Used to supply power to output emitter follower only. Apply equivalent voltage to 3 channels.
25 30 35	OUTPUT (R) OUTPUT (G) OUTPUT (B)	Variable		<ul style="list-style-type: none"> A resistor is needed on the GND side. Set discretionally to maximum 15mA, depending on the required driving capacity.
36	OSD adjust	Apply at open 5.5V		<ul style="list-style-type: none"> Pulled up directly to Vcc or open if not used.