

DESCRIPTION

M52769FP is a semiconductor integrated circuit consisting of VIF/SIF signal processing for CTVs and VCRs. M52769FP corresponds to FM radio and provide low cost and high performance system with the coil-less AFT.

FEATURES

- FM radio receiving is available without FM radio IC and external filter
- Built-in FM radio carrier indicator
- Coil-less AFT.
- The PLL-SPLIT system provides good sound sensitivity and reduces buzz.
- Video output is 2.0Vp-p through EQ AMP.
- Built-in QIF AGC.
- Improve over modulation characteristics and Vcc ripple rejection.

RECOMMENDED OPERATING CONDITIONS

Supply Voltage Range (Vcc) • • • • • 4.75 to 5.25 V

Rated Supply Voltage (Vcc) • • • • • 5.0 V

APPLICATION

TV,VTR

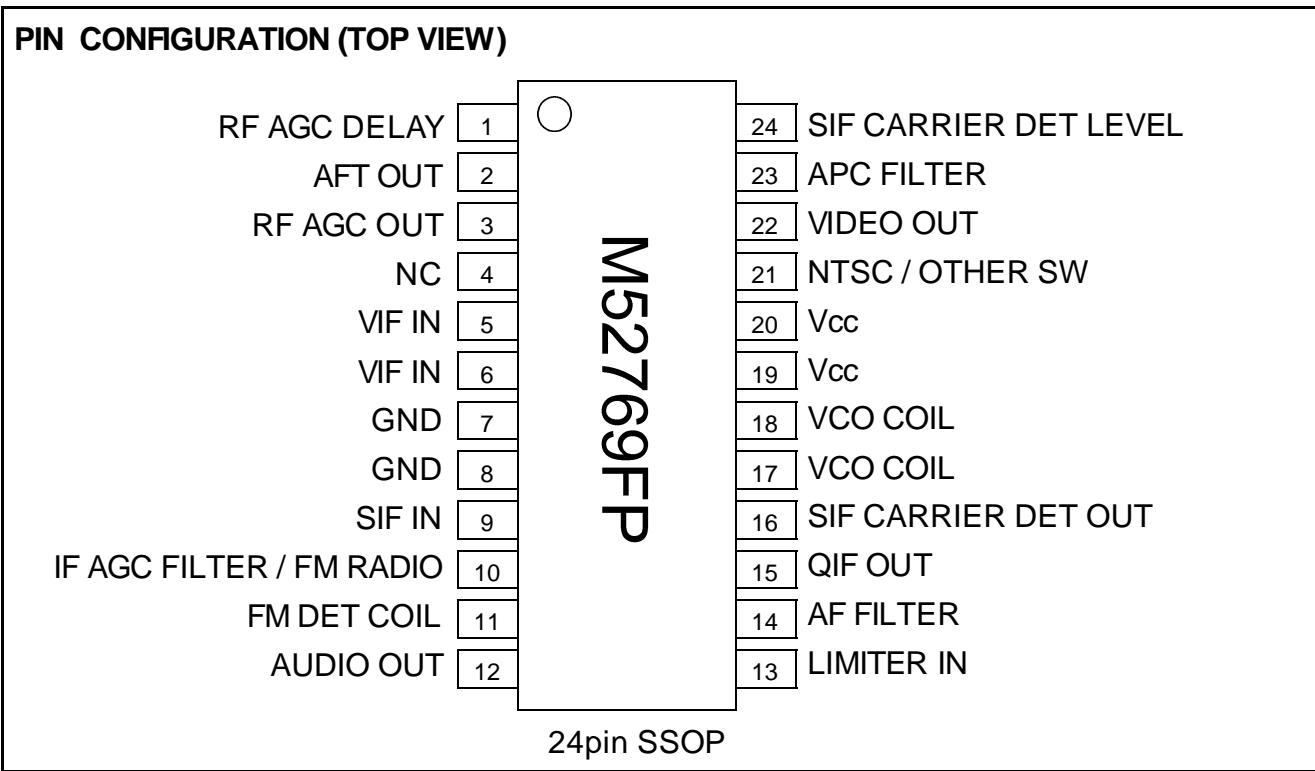

BLOCK DIAGRAM and PERIPHERAL CIRCUIT

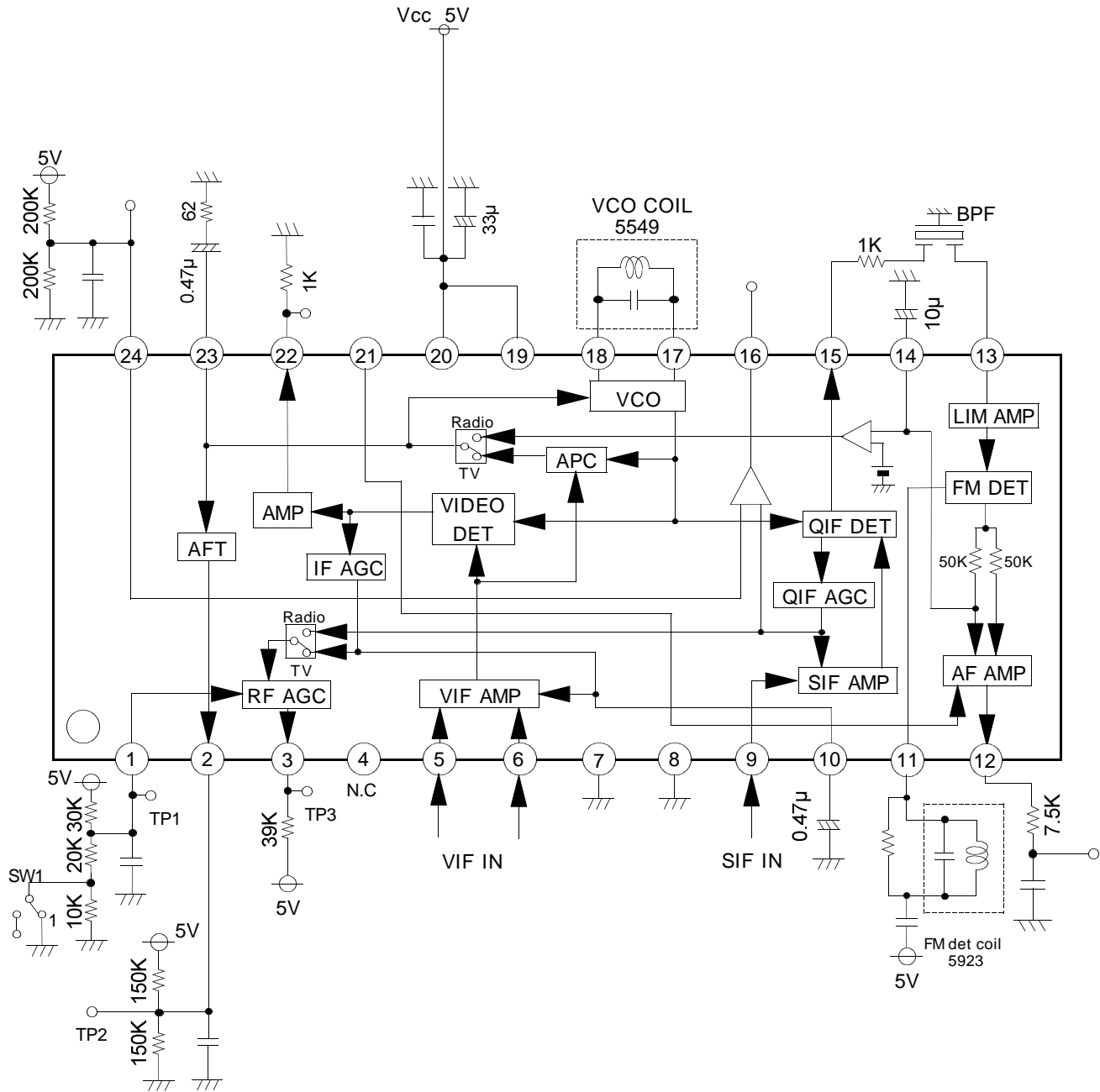

ABSOLUTE MAXIMUM RATINGS

(Ta = 25°C, unless otherwise noted)

Parameter	Symbol	Ratings	Unit	Note
Supply Voltage 1	Vcc	6.0	V	
Power Consumption	Pd	1190	mW	
Operating Temperature	Topr	-20 to +75	°C	
Storage Temperature	Tstg	-40 to +150	°C	

Temperature Characteristics (maximum ratings)

Mounting in standard circuit board

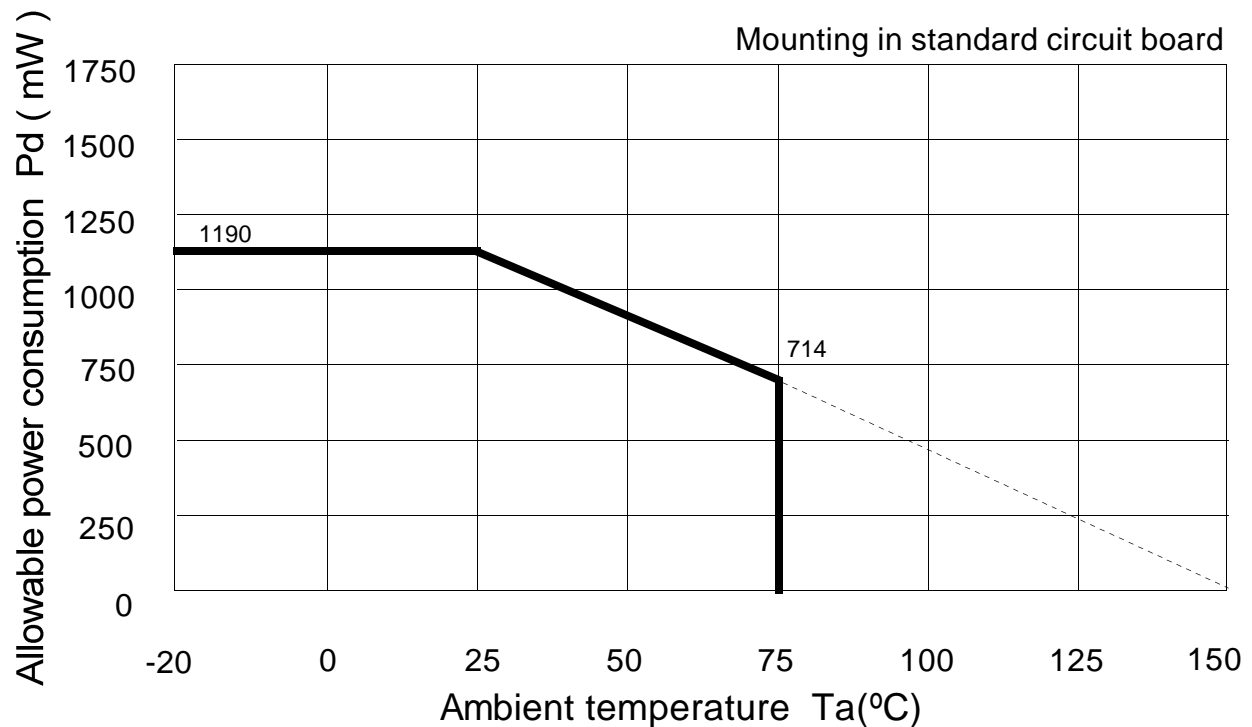

ELECTRICAL CHARACTERISTICS ($V_{CC}=5V, T_a=25^{\circ}C$ unless otherwise noted)
TV Mode

NO	Parameter	Symbol	Test Circuit	Test Point	Input Point	Input SG	Measurement condition			Limits			Unit	Note
							External power		switches set to position 1 unless otherwise noted	MIN	TYP	MAX		
							V10	V14						
1	Circuit Current 1 $V_{CC}=5V$	ICC1	1	A	VIF IN	SG1	—	—	$V_{CC}=5V$ $SW19=2$	30	43	56	mA	
2	Video Output DC Voltage 1	V22	1	TP22A	—	—	0	—	$SW10=2$	3.2	3.5	3.8	V	
3	Video Output Voltage 1	Vo det	1	TP22A	VIF IN	SG1	—	—		1.8	2.1	2.4	Vp-p	
4	Video S/N	Video S/N	1	TP22B	VIF IN	SG2	—	—	$SW22=2$	51	56	—	dB	1
5	Video Band Width	BW	1	TP22A	VIF IN	SG3	Variable	—	$SW10=2$	6.0	7.0	—	MHz	2
6	Input Sensitivity	VIN MIN	1	TP22A	VIF IN	SG4	—	—		—	48	52	dB μ	3
7	Maximum Allowable Input	VIN MAX	1	TP22A	VIF IN	SG5	—	—		101	105	—	dB μ	4
8	AGC Control Range Input	GR	—	—	—	—	—	—		50	57	—	dB	5
9	IF AGC Voltage	V10	1	TP10	VIF IN	SG6	—	—		2.9	3.2	3.5	V	
10	Maximum IF AGC Voltage	V10H	1	TP10	—	—	—	—		4.0	4.4	—	V	
11	Minimum IF AGC Voltage	V10L	1	TP10	VIF IN	SG7	—	—		2.2	2.4	2.6	V	
12	Maximum RF AGC Voltage	V3H	1	TP3	VIF IN	SG6	—	—		4.2	4.7	—	V	
13	Minimum RF AGC Voltage	V3L	1	TP3	VIF IN	SG7	—	—		—	0.1	0.5	V	
14	RF AGC Delay Point	V3	1	TP3	VIF IN	SG8	—	—	$SW1=1$	89	92	95	dB μ	6
15	Capture Range U	CL-U	1	TP22A	VIF IN	SG9	—	—		1.0	1.7	—	MHz	7
16	Capture Range L	CL-L	1	TP22A	VIF IN	SG9	—	—		1.8	2.4	—	MHz	8
17	Capture Range T	CL-T	—	—	—	—	—	—		3.1	4.1	—	MHz	9
18	AFT Sensitivity	μ	1	TP2	VIF IN	SG10	—	—		23	35	70	mV/kHz	10
19	AFT Maximum Voltage	V2H	1	TP2	VIF IN	SG10	—	—		3.85	4.15	—	V	10
20	AFT Minimum Voltage	V2L	1	TP2	VIF IN	SG10	—	—		—	0.7	1.2	V	10

NO	Parameter	Symbol	Test Circuit	Test Point	Input Point	Input SG	Measurement condition			Limits			Unit	Note
							External power		switches set to position 1 unless otherwise noted	MIN	TYP	MAX		
							V10	V14						
21	Inter Modulation	IM	1	TP22A	VIF IN	SG11	Variable	—	SW10=2	35	40	—	dB	11
22	Differential Gain	DG	1	TP22A	VIF IN	SG12	—	—		—	2	5	%	
23	Differential Phase	DP	1	TP22A	VIF IN	SG12	—	—		—	2	5	deg	
24	Sync. tip level	V22 SYNC	1	TP22A	VIF IN	SG2	—	—		0.85	1.15	1.45	V	
25	VIF Input Resistor	RINV	2	TP5	—	—	—	—			1.2		kΩ	
26	VIF Input capacitance	CINV	2	TP5	—	—	—	—			5		pF	

NO	Parameter	Symbol	Test Circuit	Test Point	Input Point	Input SG	Measurement condition			Limits			Unit	Note
							External power		switches set to position 1 unless otherwise noted	MIN	TYP	MAX		
							V10	V14						
27	QIF Output Voltage 1	QIF1	1	TP15	VIF IN SIF IN	SG2 SG13	—	—		90	96	102	dBμ	
28	QIF Output Voltage 2	QIF2	1	TP15	VIF IN SIF IN	SG2 SG14	—	—		90	96	102	dBμ	
29	AF Output (4.5MHz)	VoAF1	1	TP12	LIM IN	SG15	—	—		300	430	615	mVrms	
30	AFOutput Distortion (4.5MHz)	THD AF1	1	TP12	LIM IN	SG15	—	—		—	0.2	1.0	%	
31	Limiting Sensitivity (4.5MHz)	LIM1	1	TP12	LIM IN	SG16	—	—		—	55	60	dBμ	12
32	AM Rejection (4.5MHz)	AMR1	1	TP12	LIM IN	SG17	—	—		40	46	—	dB	13
33	AF S/N (4.5MHz)	AF S/N1	1	TP12	LIM IN	SG19	—	—		46	53	—	dB	14
34	SIF Input Resistor	RINS	2	TP9	—	—	—	—		—	1.5	—	kΩ	
35	SIF Input capacitance	CINS	2	TP9	—	—	—	—		—	4	—	pF	

FM Radio Mode

NO	Parameter	Symbol	Test Circuit	Test Point	Input Point	Input SG	Measurement condition			Limits			Unit	Note
							External power		switches set to position 1 unless otherwise noted	MIN	TYP	MAX		
							V10	V14						
32	SIF detection out High Voltage	V16H	1	TP16	—	—	0	—	SW10=2	4.0	4.8	—	V	
33	SIF detection out Low Voltage	V16L	1	TP16	SIF IN	SG20	0	—	SW10=2	—	0.2	1.0	V	
34	SIF detection Threshold Point	TSIF	1	TP16	SIF IN	SG21	0	—	SW10=2	85	90	95	dBμ	15
35	RF AGC Delay Point	V3F	1	TP3	SIF IN	SG21	0	—	SW1=2 SW10=2	85	90	95	dBμ	16
36	AF Output	VoF	1	TP12	LIM IN	SG22	0	—	SW10=2	400	560	800	mVrms	
37	AF Output Distortion	THD F	1	TP12	LIM IN	SG22	0	—	SW10=2	—	0.2	1.0	%	
38	AF S/N	S/N F	1	TP12	LIM IN	SG19	0	—	SW10=2	55	62	—	dB	17

Measuring Circuit Diagram1

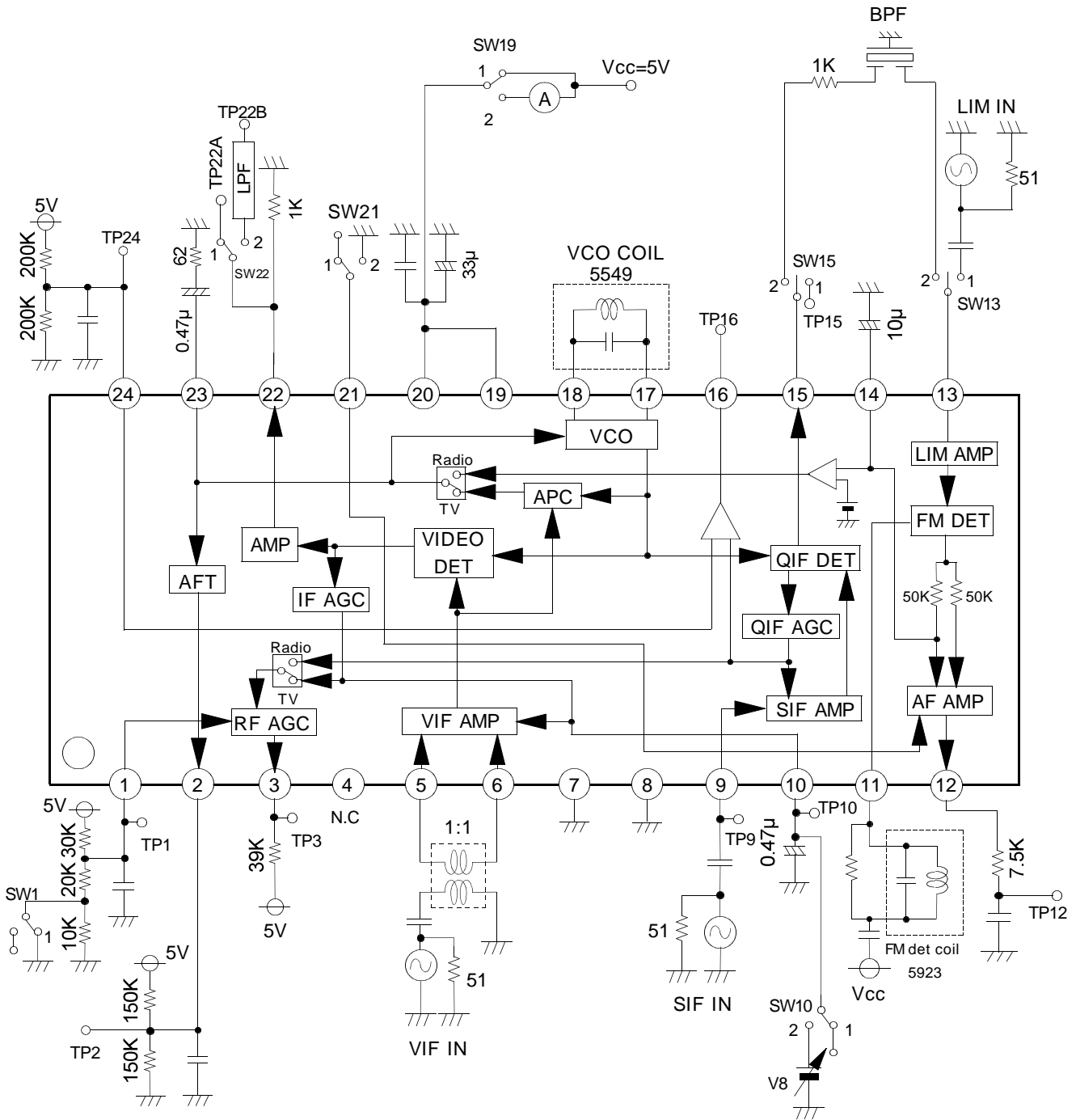

* All capacitor is 0.01µF, unless otherwise noted.

* The Measuring Circuit 1 is Mitsubishi standard evaluation fixture.

Measuring Circuit Diagram2

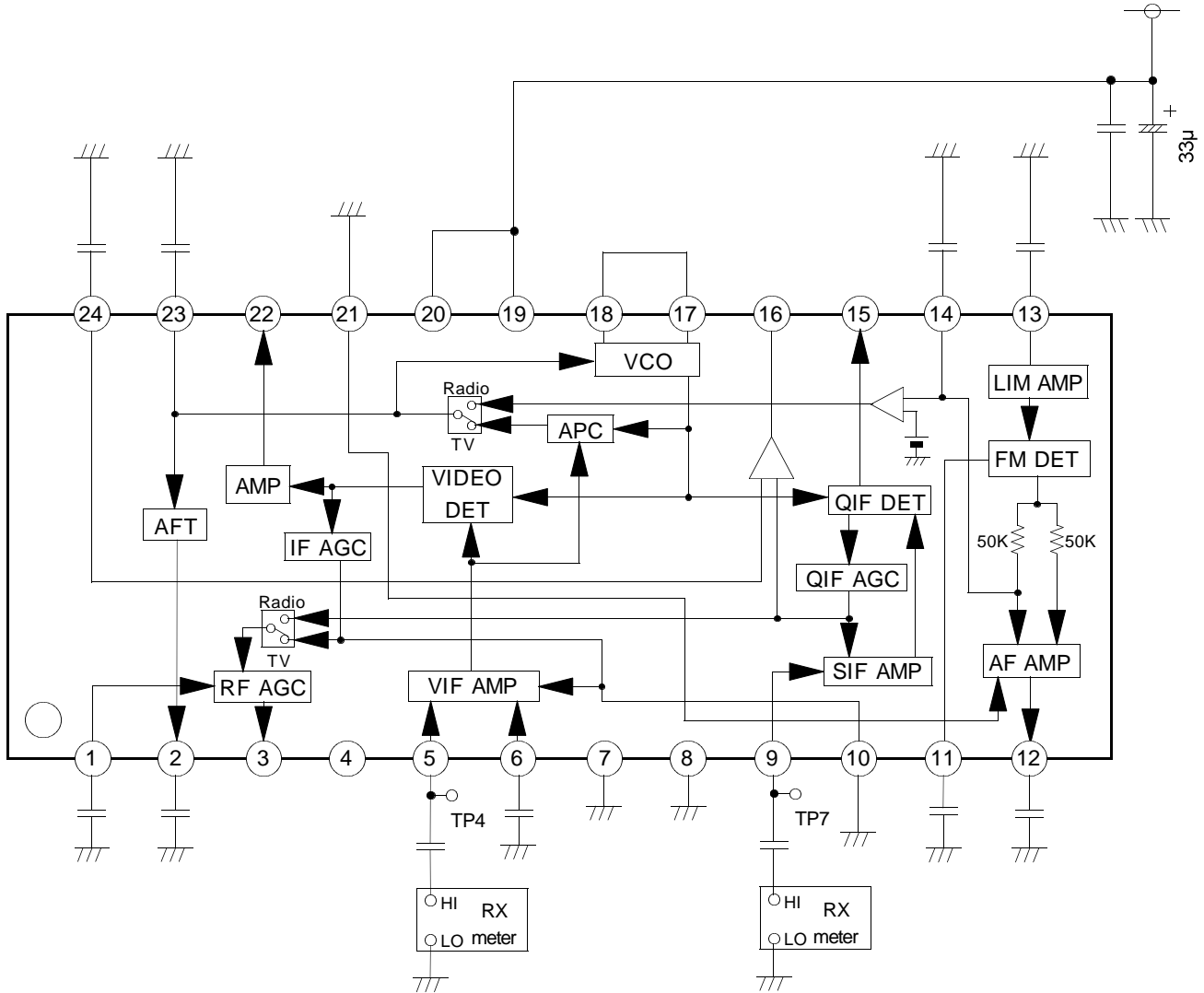

* All capacitor is 0.01µF, unless otherwise noted.

INPUT SIGNAL

SG	50ohm Termination			
1	fo=58.75MHz	AM 20 KHz	77.8 %	90 dBμ
2	fo=58.75MHz	90 dBμ	Cw	
3	f1=58.75MHz	90 dBμ	Cw	} Mixed Signal
	f2=Frequency Variable	70 dBμ	Cw	
4	fo=58.75MHz	AM 20 KHz	77.8%	Level Variable
5	fo=58.75MHz	AM 20 KHz	14.0%	Level Variable
6	fo=58.75 MHz	80 dBμ	Cw	
7	fo=58.75 MHz	110 dBμ	Cw	
8	fo=58.75 MHz	Level Variable	Cw	
9	fo=Frequency Variable	AM 20 KHz	77.8 %	90 dBμ
10	fo=Frequency Variable	90 dBμ	Cw	
11	f1=58.75MHz	90 dBμ	Cw	} Mixed Signal
	f2=55.17MHz	80 dBμ	Cw	
	f3=54.25MHz	80 dBμ	Cw	
12	fo=58.75MHz	87.5 %	TV modulation Ten-step waveform	
	Sync Tip Level	90 dBμ		
13	fo=54.25MHz	95 dBμ	Cw	
14	fo=54.25MHz	75 dBμ	Cw	
15	fo=4.5 MHz	90 dBμ	FM 400 Hz ±25 KHz dev	
16	fo=4.5 MHz	Level Variable	FM 400Hz ±25KHz dev	
17	fo=4.5 MHz	100 dBμ	AM 400 Hz	30 %
18	fo=4.5 MHz	Level Variable	Cw	
19	fo=4.5 MHz	90 dBμ	Cw	
20	fo=54.25 MHz	90 dBμ	Cw	
21	fo=54.25 MHz	Level Variable	Cw	
22	fo=4.5 MHz	90 dBμ	FM 400 Hz ±75 KHz dev	

Notes

1. Video S/N

Input SG2 into VIF IN and measure the video out(Pin 22) noise in r.m.s at TP22-B through a 5MHz (-3dB) L.P.F.

$$S/N=20 \log \left(\frac{0.7 \times V_o \text{ det}}{\text{NOISE}} \right) \quad (\text{dB})$$

2. Video Band width: BW

1. Measure the 1MHz component level of Video output TP22A with a spectrum analyzer when SG3($f_2=57.75\text{MHz}$) is input into VIF IN. At that time, measure the voltage at TP10 with SW10, set to position 2, and then fix V10 at that voltage.
2. Reduce f_2 and measure the value of (f_2-f_1) when the (f_2-f_1) component level reaches -3dB from the 1MHz component level as shown below.

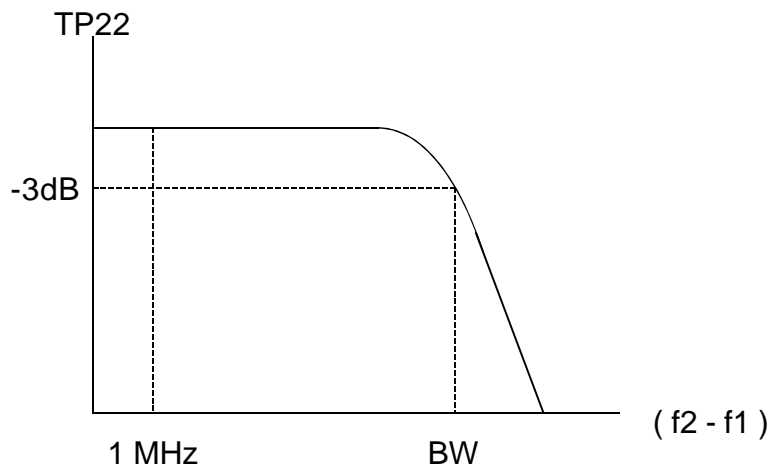

3. Input Sensitivity: $V_{IN \text{ MIN}}$

Input SG4 ($V_i=90\text{dB}\mu$) into VIF IN, and then gradually reduce V_i and measure the input level when the 20KHz component of Video output TP22A reaches -3dB from $V_o \text{ det}$ level.

4. Maximum Allowable Input: $V_{IN \text{ MAX}}$

1. Input SG5 ($V_i=90\text{dB}\mu$) into VIF IN, and measure the level of the 20KHz component of Video output.
 2. Gradually increase the V_i of SG and measure the input level when the output reaches -3dB.
-

5. AGC Control Range: GR

$$GR = V_{IN \text{ MAX}} - V_{IN \text{ MIN}} \quad (\text{dB})$$

6. RF AGC Operating Voltage: V3

Input SG8 into VIF IN and gradually reduce V_i and then measure the input level when RF AGC output TP3 reaches $1/2 V_{CC}$, as shown below.

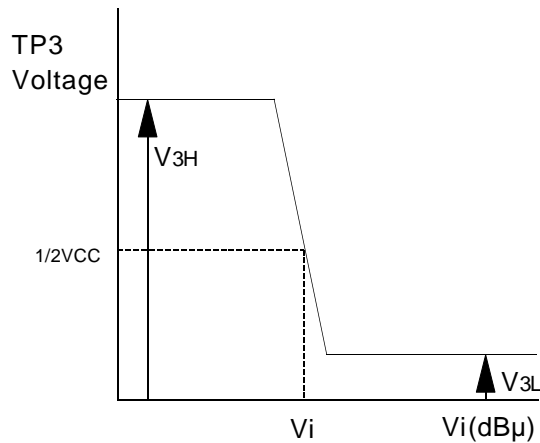

7. Capture range: CL - U

1. Increase the frequency of SG9 until the VCO is out of locked-oscillation.
2. Decrease the frequency of SG9 and measure the frequency f_U when the VCO locks.

$$CL - U = f_U - 58.75 \quad (\text{MHz})$$

8. Capture range: CL - L

1. Decrease the frequency of SG9 until the VCO is out of locked-oscillation.
2. Increase the frequency of SG9 and measure the frequency f_L when the VCO locks.

$$CL - L = 58.75 - f_L \quad (\text{MHz})$$

9. Capture range: CL - T

$$CL - T = CL - U + CL - L \quad (\text{MHz})$$

10. AFT sensitivity u , Maximum AFT voltage V_{2H} , Minimum AFT voltage V_{2L}

1. Input SG10 into VIF IN, and set the frequency of SG10 so that the voltage of AFT output TP2 is 3V . This frequency is named $f(3)$.
2. Set the frequency of SG10 so that the AFT output voltage is 2V. This frequency is named $f(2)$
3. IN the graph, maximum and minimum DC voltage is V_{2H} and V_{2L} , respectively.

$$u = \frac{1000 \text{ (mV)}}{f(2) - f(3) \text{ (kHz)}} \quad (\text{mV / kHz})$$

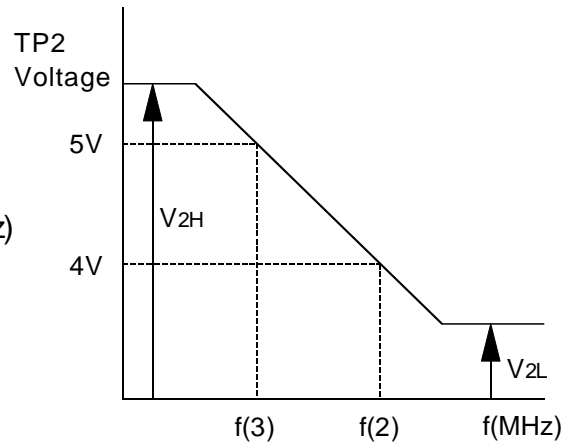

11. Inter modulation: IM

1. Input SG11 into VIF IN, and measure EQ output TP22A with an oscilloscope.
2. Adjust AGC filter voltage V_{10} so that the minimum DC level of the output waveform is 1.0V.
3. At this time, measure TP22A with a spectrum analyzer .
The inter modulation is defined as a difference between 0.92MHz and 3.58 MHz frequency components.

12. Limiting Sensitivity: LIM

1. Input SG16 ($V_i=90\text{dB}\mu$) into SIF IN, and measure the 400Hz component level of AF output TP12.
2. Lower the input level of SG16, and measure the level of SG16 when the VoAF level reaches -3dB.

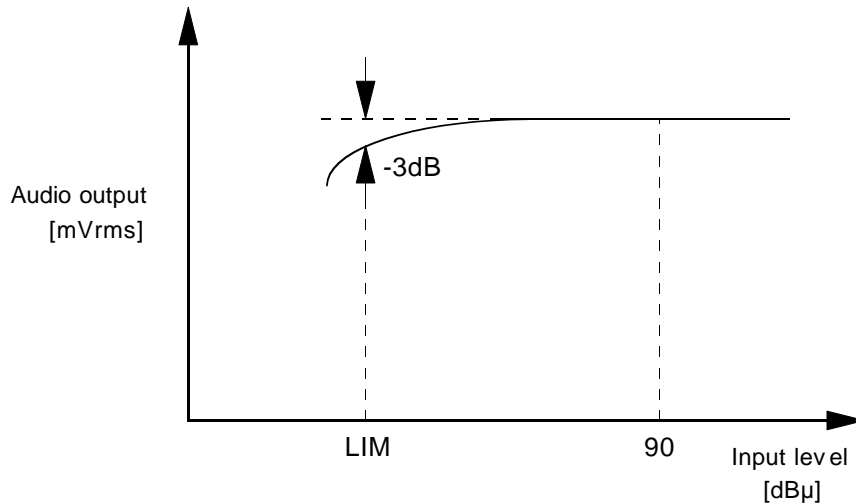

13. AM Rejection: AMR

1. Input SG17 into SIF IN, and measure the output level of AF OUT (TP12). This level is named VAM.

2. AMR is;

$$\text{AMR} = 20\log \left(\frac{\text{VoAF (mVr.m.s)}}{\text{VAM (mVr.m.s)}} \right) \quad (\text{dB})$$

14. AF S/N: AF S/N

1. Input SG19 into SIF IN, and measure the output noise level of AF OUT (TP12). This level is named VN.

2. S/N is;

$$\text{S/N} = 20\log \left(\frac{\text{VoAF (mVr.m.s)}}{\text{VN (mVr.m.s)}} \right) \quad (\text{dB})$$

15. SIF detection threshold level TSIF

SG21 is applied to SIF IN and the input amplitude is swept.
Then, the level of SG21, TSIF, is measured at the time when the DC voltage of SIF CARRIER DET OUT (TP16) has just begun to vary.

16. RF AGC voltage V3F

SG21 is applied to SIF IN and the input amplitude is swept.
Then, the level of SG21, V3F, is measured at the time when the DC voltage of RF AGC OUT (TP3) has just reached $1/2V_{cc}$.

17. AF S/N (S/N F)

1. SG19 is applied to SIF IN and the output noise of AUDIO OUT (TP12) is measured. The measured noise is named VNF.

2. S/N F is,

$$S/N F = 20 \log \left(\frac{VoF [mVr.m.s]}{VNF [mVr.m.s]} \right) \quad [dB]$$

VCO coil adjustment methods

1. Input SG2 (fo=58.75MHz, 90dB μ CW) into VIF IN.
2. And adjust the coil until the voltage of AFT output reaches about $V_{cc}/2=2.5V$.

FM DET coil adjustment methods

1. The first thing, adjust the VCO coil.
2. Input SG13 (fo=54.25MHz, 95dB μ CW) into SIF IN.
3. Change the switch of SW13 and SW15 to 2 position.
4. Change to FM RADIO mode (V10=0V).
5. Adjust the DC voltage of AFT OUT to $V_{cc}/2$ and SIF det OUT to Low (under 1V).

DETAILED DIAGRAM OF PACKAGE OUTLINE

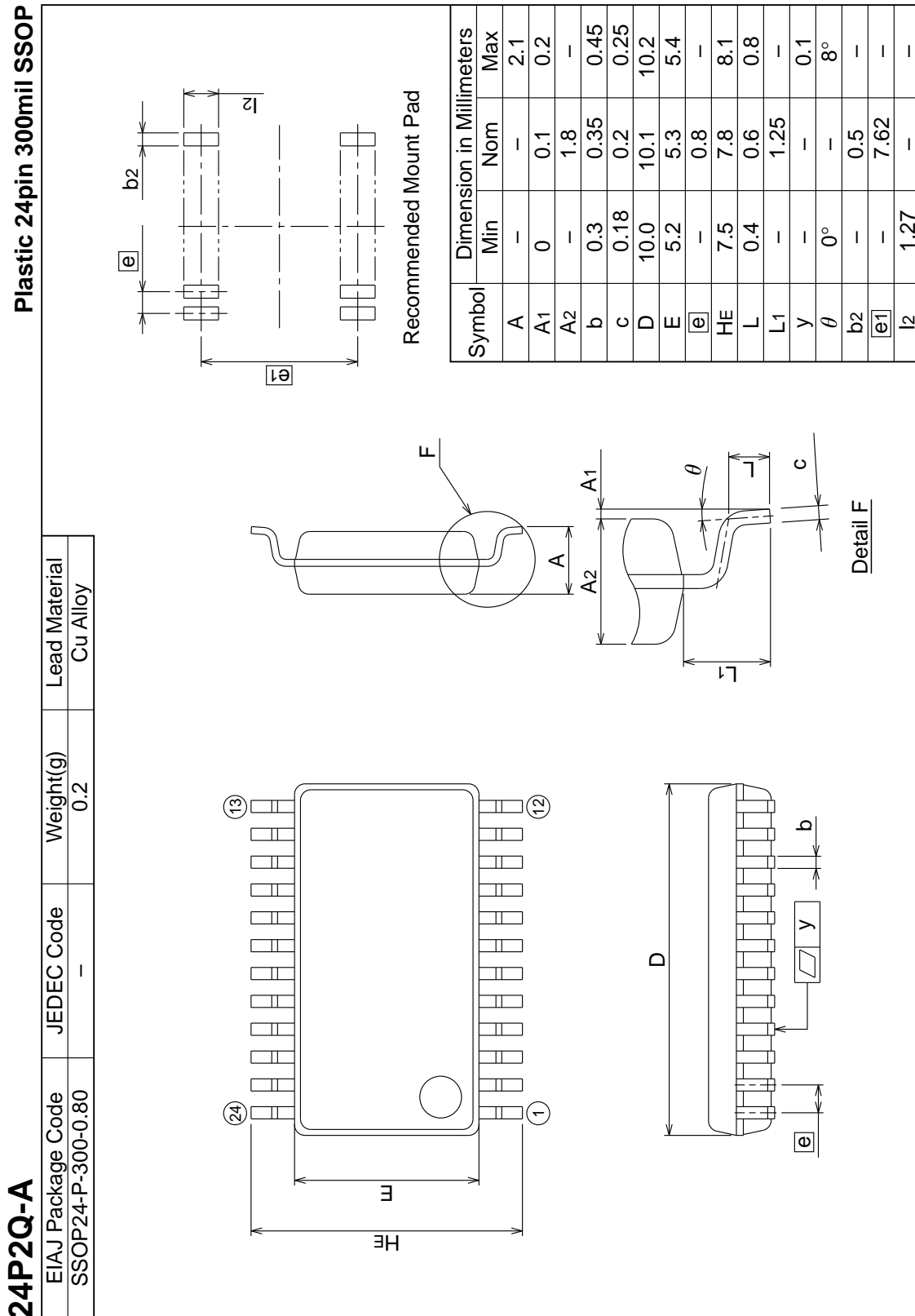

Keep safety first in your circuit designs!

●Mitsubishi Electric Corporation puts the maximum effort into making semiconductor products better and more reliable, but there is always the possibility that trouble may occur with them. Trouble with semiconductors may lead to personal injury, fire or property damage. Remember to give due consideration to safety when making your circuit designs, with appropriate measures such as (i) placement of substitutive, auxiliary circuits, (ii) use of non-flammable material or (iii) prevention against any malfunction or mishap.

Notes regarding these materials

●These materials are intended as a reference to assist our customers in the selection of the Mitsubishi semiconductor product best suited to the customer's application; they do not convey any license under any intellectual property rights, or any other rights, belonging to Mitsubishi Electric Corporation or a third party.

●Mitsubishi Electric Corporation assumes no responsibility for any damage, or infringement of any third-party's rights, originating in the use of any product data, diagrams, charts, programs, algorithms, or circuit application examples contained in these materials.

●All information contained in these materials, including product data, diagrams, charts, programs and algorithms represents information on products at the time of publication of these materials, and are subject to change by Mitsubishi Electric Corporation without notice due to product improvements or other reasons. It is therefore recommended that customers contact Mitsubishi Electric Corporation or an authorized Mitsubishi Semiconductor product distributor for the latest product information before purchasing a product listed herein.

The information described here may contain technical inaccuracies or typographical errors. Mitsubishi Electric Corporation assumes no responsibility for any damage, liability, or other loss rising from these inaccuracies or errors.

Please also pay attention to information published by Mitsubishi Electric Corporation by various means, including the Mitsubishi Semiconductor home page (<http://www.mitsubishichips.com>).

●When using any or all of the information contained in these materials, including product data, diagrams, charts, programs, and algorithms, please be sure to evaluate all information as a total system before making a final decision on the applicability of the information and products. Mitsubishi Electric Corporation assumes no responsibility for any damage, liability or other loss resulting from the information contained herein.

●Mitsubishi Electric Corporation semiconductors are not designed or manufactured for use in a device or system that is used under circumstances in which human life is potentially at stake. Please contact Mitsubishi Electric Corporation or an authorized Mitsubishi Semiconductor product distributor when considering the use of a product contained herein for any specific purposes, such as apparatus or systems for transportation, vehicular, medical, aerospace, nuclear, or undersea repeater use.

●The prior written approval of Mitsubishi Electric Corporation is necessary to reprint or reproduce in whole or in part these materials.

●If these products or technologies are subject to the Japanese export control restrictions, they must be exported under a license from the Japanese government and cannot be imported into a country other than the approved destination.

Any diversion or reexport contrary to the export control laws and regulations of Japan and/or the country of destination is prohibited.

●Please contact Mitsubishi Electric Corporation or an authorized Mitsubishi Semiconductor product distributor for further details on these materials or the products contained therein.