

M52766FP

PLL SPLIT VIF / SIF

DESCRIPTION

The M52766FP is a semiconductor IC with PLL system of VIF/ SIF.

The circuit includes video UF amplifier, PLL video detector, IFAGC, RFAGC, VCO, AFT, LOCK DET, EQ, REG, QIF amplifier, QIF detector, QIF AGC, LIM, FM detector function.

The circuit realize no abjstment SIF, nothing coil AFT.

FEATURES

- Dynamic AGC realizes high speed AGC with double filtre.
- The M52766FP can correspond to 2tipe sound career, from change on standard board, with sound LIM input have 2pins (12,13pin).
- Sound FM detection can correspond to wide SIF signal, with PLL system and no abjstment.
- The N52766FP correspond to PLL split system and intercareer system.
- AFT coil is necessary.
- AFT mute is not used.
- The M52766FP optimum for VTR and color TV, with video output-pin, because this IC has a built in EQ amplifier.
- VCC correspond to 5V, be main strem of tuner in future.
- Flat package is 24-pin SSOP of mini flat (0.8mm pitch), suitable for space saving.

PIN CONFIGURATION (TOP VIEW)

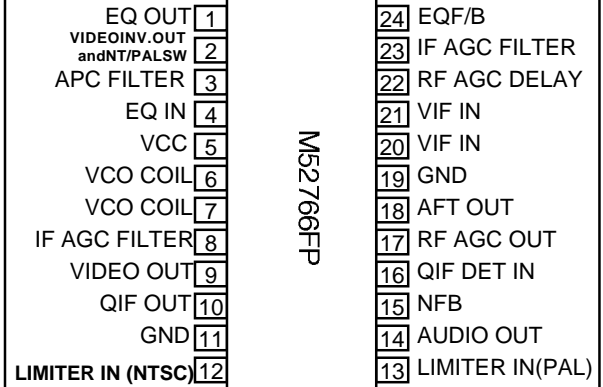

APPLICATION

TV sets, VTR tuners.

RECOMMEND OPERATING CONDITION

Supply voltage range 5.0 ± 0.25V
Recommended supply voltage 5.0V

BLOCK DIAGRAM

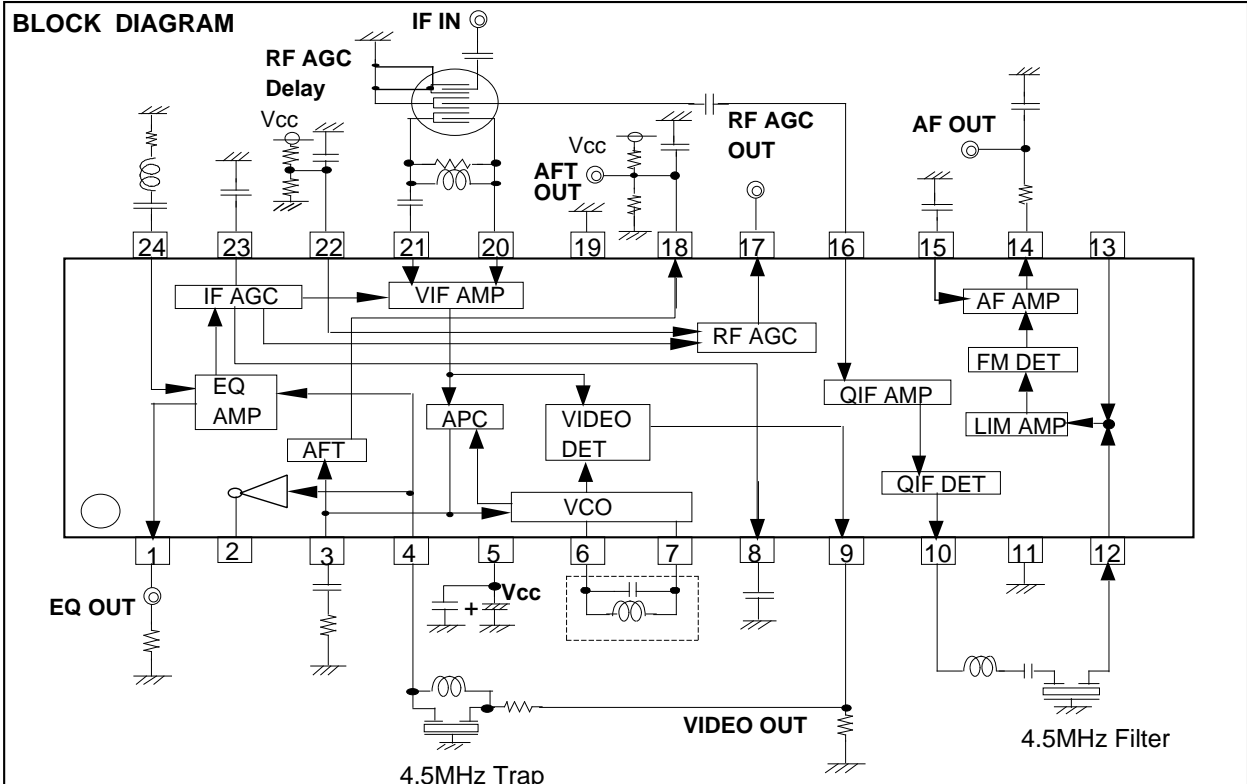

Absolute maximum ratings (Ta = 25°C, unless otherwise noted)

Parameter	Symbol	Ratings	Unit	Note
Supply Voltage 1	Vcc	6.0	V	
Power Consumption	Pd	1524	mW	
Operating Temperature	Topr	-20 to +75	°C	
Storage Temperature	Tstg	-40 to +150	°C	
Surge voltage resistance	Surge	±200	V	surge protection capacitance 200pF resistance 0Ω

* There is not all pins problem about surge, but the case of use pay attention about latch up because the ninth pin is weak a few.

Temperature Characteristics (maximum ratings)

Mounting in standard circuit board

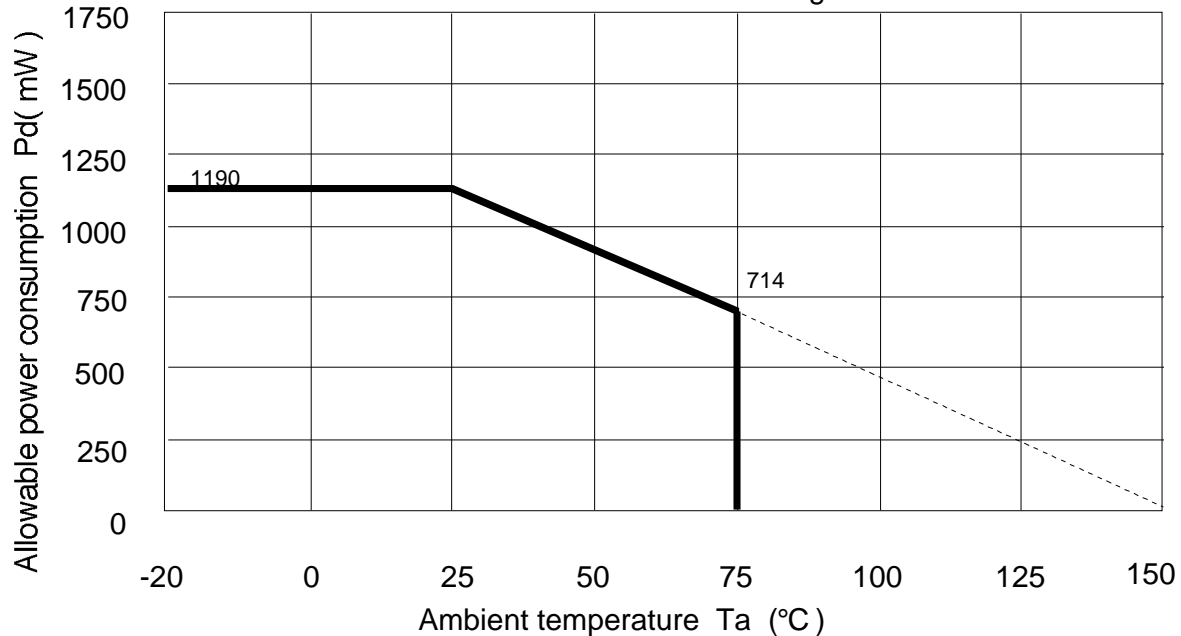

Recommended Operating Condition (Ta = 25°C, unless otherwise noted)

Supply Voltage Range (Vcc) ••••• 4.75 to 5.25 V

Rated Supply Voltage (Vcc) ••••• 5.0 V

Electrical Characteristics (Vcc=5V, Ta=25°C unless otherwise noted)

VIF Section

No.	Parameter	Symbol	Test Circuit	Test Point	Input Point	Input SG	Measurement switches set to position 1 unless otherwise noted	Limits			Unit	Note
								MIN	TYP	MAX		
1	Circuit Current 1 Vcc=5V	Icc1	1	A	-	-	SW5=2	40	56	72	mA	
2	Video Output DC Voltage 1	V1	1	TP1A	-	-	SW23=2 V23=0V	3.1	3.5	3.9	V	
3	Video Output Voltage 9	Vo det9	1	TP9	VIF IN	SG1		0.85	1.1	1.35	Vp-p	
4	Video Output Voltage 1	Vo det	1	TP1A	VIF IN	SG1		1.77	2.1	2.43	Vp-p	
5	Video S/N	Video S/N	1	TP1B	VIF IN	SG2	SW1=2	51	56	-	dB	1
6	Video Band Width	BW	1	TP1A	VIF IN	SG3	SW23=2 V23=Variable	5.0	7.0	-	MHz	2
7	Input Sensitivity	VIN MIN	1	TP1A	VIF IN	SG4		-	48	52	dBμ	3
8	Maximum Allowable Input	VIN MAX	1	TP1A	VIF IN	SG5		101	105	-	dBμ	4
9	AGC Control Range Input	GR	-	-	-	-		50	57	-	dB	5
10	IF AGC Voltage 1	V23	1	TP23	VIF IN	SG6		2.47	2.75	3.03	V	
11	Maximum IF AGC Voltage 1	V23H	1	TP23	-	-		4.35	4.75	-	V	
12	Minimum IF AGC Voltage 1	V23L	1	TP23	VIF IN	SG7		2.06	2.25	2.45	V	
13	Maximum RF AGC Voltage	V17H	1	TP17	VIF IN	SG6		4.13	4.75	-	V	
14	Minimum RF AGC Voltage	V17L	1	TP17	VIF IN	SG7		-	0.1	0.5	V	
15	RF AGC Delay Point	V17	1	TP17	VIF IN	SG8		80	83	86	dBμ	6
16	Capture Range U	CL-U	1	TP1A	VIF IN	SG9		0.9	1.5	-	MHz	7
17	Capture Range L	CL-L	1	TP1A	VIF IN	SG9		1.3	1.8	-	MHz	8
18	Capture Range T	CL-T	1	-	-	-		2.5	3.3	-	MHz	9

No.	Parameter	Symbol	Test Circuit	Test Point	Input Point	Input SG	Measurement switches set to position 1 unless otherwise noted	Limits			Unit	Note
								MIN	TYP	MAX		
19	AFT Sensitivity	μ	1	TP18	VIF IN	SG10		20	30	70	mV/kHz	10
20	AFT Maximum Voltage	V18H	1	TP18	VIF IN	SG10		3.85	4.15	-	V	10
21	AFT Minimum Voltage	V18L	1	TP18	VIF IN	SG10		-	0.7	1.2	V	10
22	AFT defeat	AFT def 1	1	TP18	VIF IN	-		2.2	2.5	2.8	V	
23	Inter Modulation	IM	1	TP1A	VIF IN	SG11	SW23=2 V23=Variable	33	40	-	dB	11
24	Differential Gain	DG	1	TP1A	VIF IN	SG12		-	2	5	%	
25	Differential Phase	DP	1	TP1A	VIF IN	SG12		-	2	5	deg	
26	Sync. tip level	V9 SYNC	1	TP1A	VIF IN	SG2		0.95	1.35	1.75	V	
27	VIF Input Resistor	RINV	2	TP20				-	1.2	-	k Ω	
28	VIF Input capacitance	CINV	2	TP20				-	5	-	pF	
29	IF AGC Voltage 2	V8	1	TP8	VIF IN	SG6		2.40	2.75	3.11	V	
30	Maximum IF AGC Voltage 2	V8	1	TP8	VIF IN	-		3.80	4.25	-	V	
31	Minimum IF AGC Voltage 2	V8	1	TP8	VIF IN	SG7		1.95	2.25	2.55	V	
32	Video Inversion Output Voltage	Vo det INV	1	TP2	VIF IN	SG1		0.25	0.5	0.75	Vp-p	

Control Section

No.	Parameter	Symbol	Test Circuit	Test Point	Input Point	Input SG	Measurement switches set to position 1 unless otherwise noted	Limits			Unit	Note
								MIN	TYP	MAX		
33	QIF Control	CQIF	1	TP16	-	-	SW16=2	-	0.7	1.0	V	15

Electrical Characteristics (Vcc=5V, Ta=25°C unless otherwise noted)

SIF Section

No.	Parameter	Symbol	Test Circuit	Test Point	Input Point	Input SG	Measurement switches set to position 1 unless otherwise noted	Limits			Unit	Note
								MIN	TYP	MAX		
34	QIF Output Voltage 1	QIF1	1	TP10	VIF IN QIF IN	SG2 SG13		104	110	116	dBμ	
35	QIF Output Voltage 2	QIF2	1	TP10	VIF IN QIF IN	SG2 SG14		94	100	106	dBμ	
36	SIF Detection Output	Vos	1	TP10	VIF IN	SG15	SW16=2 V16=0V	94	100	106	dBμ	
37	AF Output DC Voltage	V1	1	TP14	SIF IN	SG19		1.5	2.1	2.7	V	
38	AF Output (4.5MHz)	VoAF 1	1	TP14	SIF IN	SG16	SW13=2	571	800	1142	mVrms	
39	AF Output (5.5MHz)	VoAF 2	1	TP14	SIF IN	SG21	SW2=2 SW12=2	521	730	1043	mVrms	
40	AF Output Distortion (4.5MHz)	THD AF 1	1	TP14	SIF IN	SG16	SW13=2	-	0.8	1.2	%	
41	AF Output Distortion (5.5MHz)	THD AF 2	1	TP14	SIF IN	SG21	SW2=2 SW12=2	-	0.6	1.0	%	
42	Limiting Sensitivity (4.5MHz)	LIM 1	1	TP14	SIF IN	SG17	SW13=2	-	42	55	dBμ	12
43	Limiting Sensitivity (5.5MHz)	LIM 2	1	TP14	SIF IN	SG22	SW2=2 SW12=2	-	42	55	dBμ	12
44	AM Rejection (4.5MHz)	AMR 1	1	TP14	SIF IN	SG18	SW13=2	53	62	-	dB	13
45	AM Rejection (5.5MHz)	AMR 2	1	TP14	SIF IN	SG23	SW2=2 SW12=2	54	64	-	dB	13
46	AF S/N (4.5MHz)	AF S/N 1	1	TP14	SIF IN	SG19	SW13=2	53	62	-	dB	14
47	AF S/N (5.5MHz)	AF S/N 2	1	TP14	SIF IN	SG24	SW2=2 SW12=2	54	64	-	dB	14
48	SIF Input Resistor	RINS	2	TP16				-	0.7	-	kΩ	
49	SIF Input Capacitance	CINS	2	TP16				-	4	-	pF	

Measuring Circuit Diagram 1

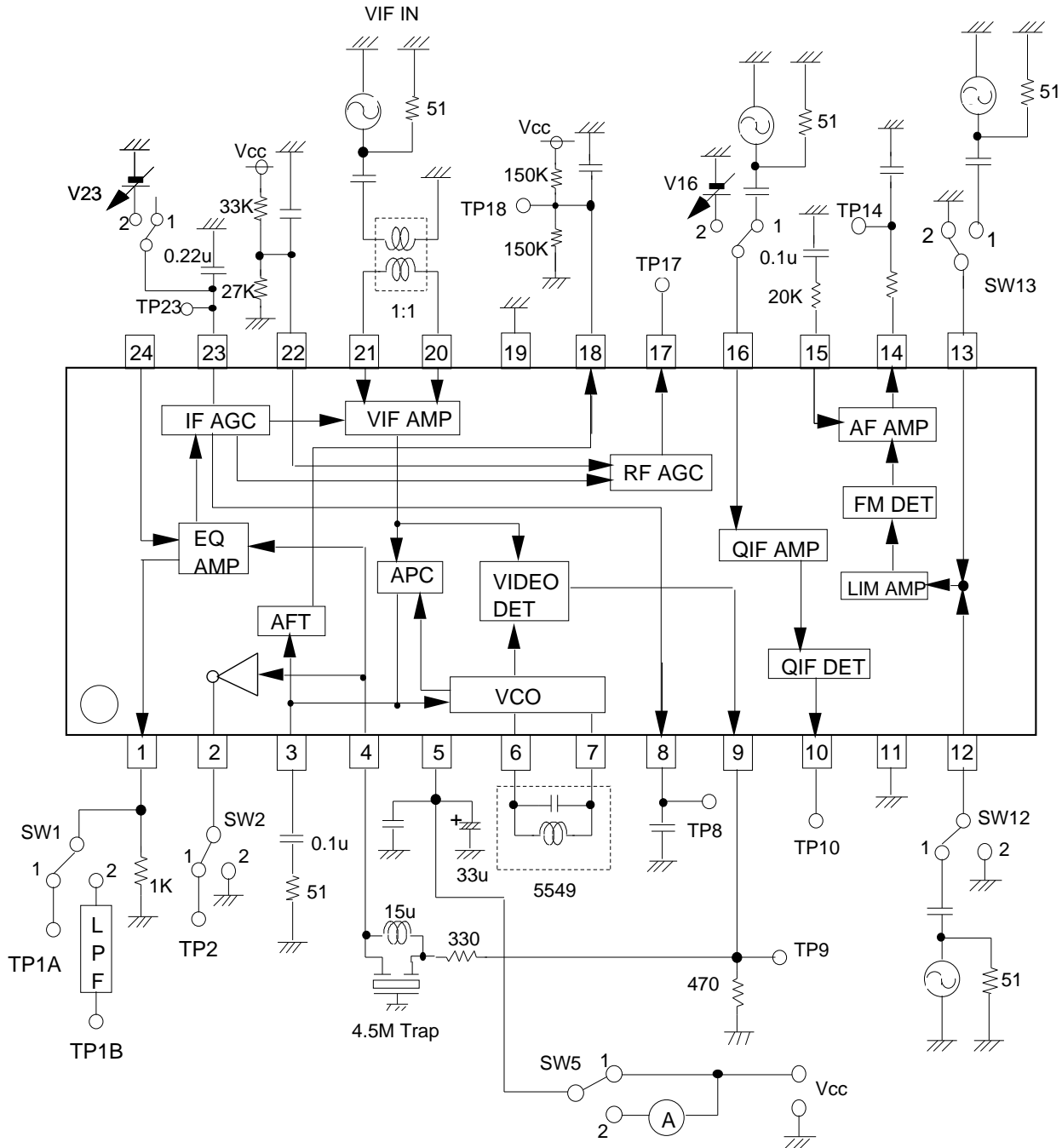

* All capacitor is 0.01μF, unless otherwise noted.

* The Measuring Circuit 1 is Mitsubishi standard evaluation fixture.

Measuring Circuit Diagram 2

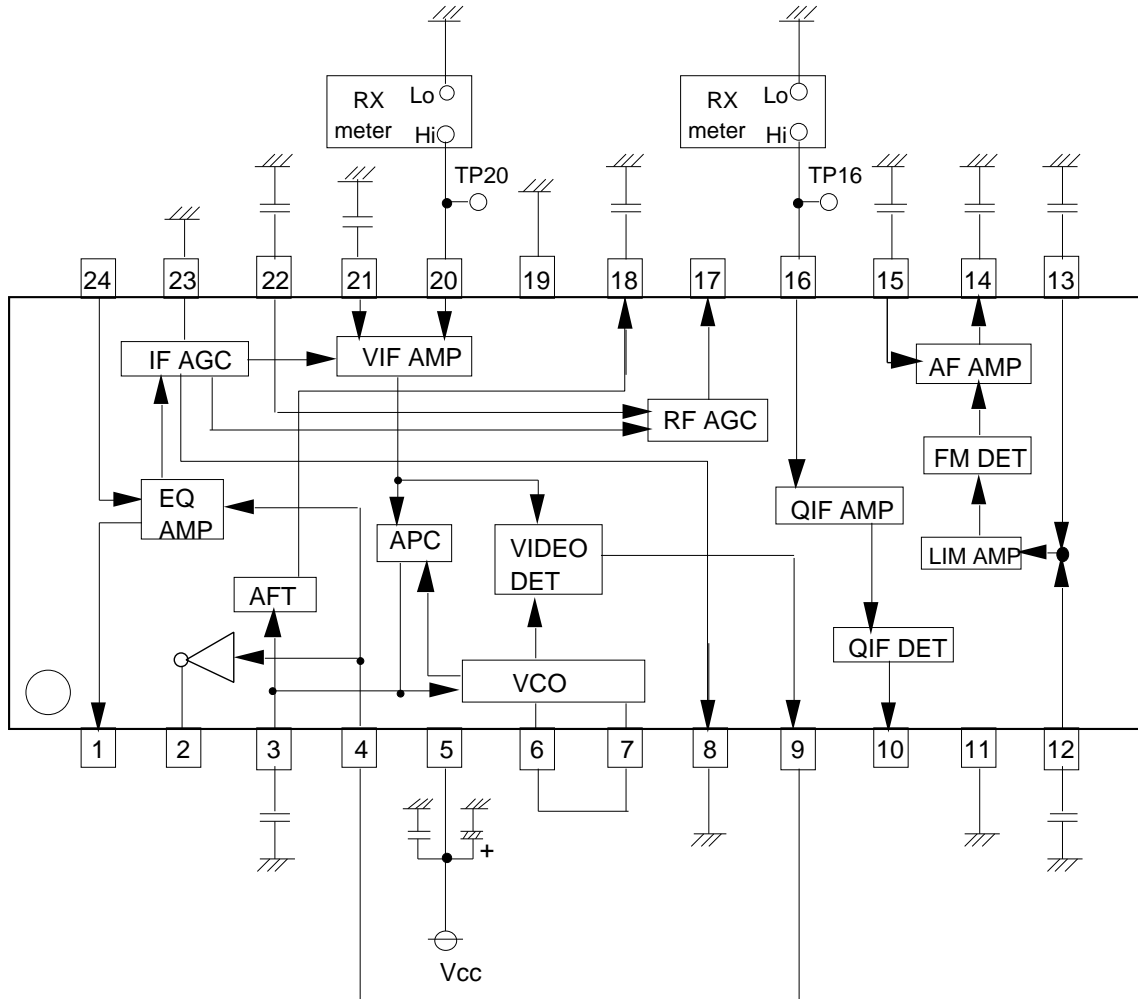

* All capacitor is 0.01 μ F, unless otherwise noted.

INPUT SIGNAL

SG	50 Ω Termination					
1	f ₀	=	58.75 MHz	AM 20 KHz	77.8 %	90 dBμ
2	f ₀	=	58.75 MHz	90 dBμ Cw		
3	f ₁	=	58.75 MHz	90 dBμ Cw	}	Mixed Signal
	f ₂	=	Frequency Variable	70 dB Cw		
4	f ₀	=	58.75 MHz	AM 20 KHz	77.8%	Level Variable
5	f ₀	=	58.75 MHz	AM 20 KHz	14.0%	Level Variable
6	f ₀ =		58.75 MHz	80 dBμ Cw		
7	f ₀	=	58.75 MHz	110 dBμ Cw		
8	f ₀	=	58.75 MHz	Cw		Level Variable
9	f ₀	=	Frequency Variable	AM 20 KHz	77.8 %	90 dBμ
10	f ₀	=	Frequency Variable	90 dBμ Cw		
11	f ₁	=	58.75 MHz	90 dBμ Cw	}	Mixed Signal
	f ₂	=	55.17 MHz	80 dBμ Cw		
	f ₃	=	54.25 MHz	80 dBμ Cw		
12	f ₀	=	58.75 MHz	87.5 %	TV modulation Ten-step waveform Sync Tip Level 90 dBμ	
13	f ₁	=	54.25 MHz	95 dBμ Cw		
14	f ₁	=	54.25 MHz	75 dBμ Cw		
15	f ₁	=	58.75 MHz	90 dBμ Cw	}	Mixed Signal
	f ₂	=	54.25 MHz	70 dBμ Cw		
16	f ₀	=	4.5 MHz	90 dBμ	FM 400 Hz ±25 KHzdev	
17	f ₀	=	4.5 MHz	Level Variable	FM 400Hz ±25KHzdev	
18	f ₀	=	4.5 MHz	90 dBμ	AM 400 Hz	30 %
19	f ₀	=	4.5 MHz	90 dBμ Cw		
20	f ₀	=	4.5 MHz	Level Variable	Cw	
21	f ₀	=	5.5 MHz	90 dBμ	FM 400 Hz ±50 KHzdev	
22	f ₀	=	5.5 MHz	Level Variable	FM 400Hz ±50KHzdev	
23	f ₀	=	5.5 MHz	90 dBμ	AM 400 Hz	30 %
24	f ₀	=	5.5 MHz	90 dBμ Cw		
25	f ₀	=	5.5 MHz	Level Variable	Cw	

Notes

1. Video S/N

Input SG2 into VIF IN and measure the video out(Pin 1) noise in r.m.s at TP1B through a 5MHz (-3dB) L.P.F.

$$S/N=20 \log \left(\frac{0.7 \times V_o \text{ det}}{\text{NOISE}} \right) \quad [\text{dB}]$$

2. Video Band Width: BW

1. Measure the 1MHz component level of Video output TP1A with a spectrum analyzer when SG3($f_2=57.75\text{MHz}$) is input into VIF IN. At that time, measure the voltage at TP23 with SW23, set to position 2, and then fix V23 at that voltage.
2. Reduce f_2 and measure the value of (f_2-f_0) when the (f_2-f_0) component level reaches -3dB from the 1MHz component level as shown below.

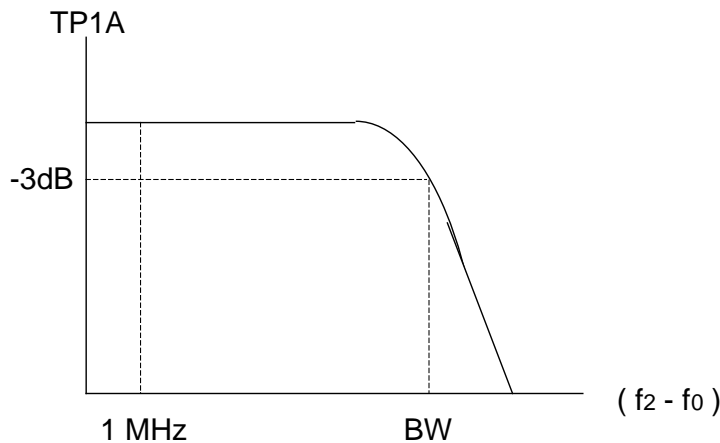

3. Input Sensitivity: VIN MIN

Input SG4 ($V_i=90\text{dB}\mu$) into VIF IN, and then gradually reduce V_i and measure the input level when the 20KHz component of Video output TP1A reaches -3dB from $V_o \text{ det}$ level.

4. Maximum Allowable Input: VIN MAX

1. Input SG5 ($V_i=90\text{dB}\mu$) into VIF IN, and measure the level of the 20KHz component of Video output.
2. Gradually increase the V_i of SG and measure the input level when the output reaches -3dB.

5. AGC Control Range: GR

$$GR = V_{IN \text{ MAX}} - V_{IN \text{ MIN}} \quad [dB]$$

6. RF AGC Operating Voltage: V17

Input SG8 into VIF IN and gradually reduce V_i and then measure the input level when RF AGC output TP17 reaches $1/2 V_{CC}$, as shown below.

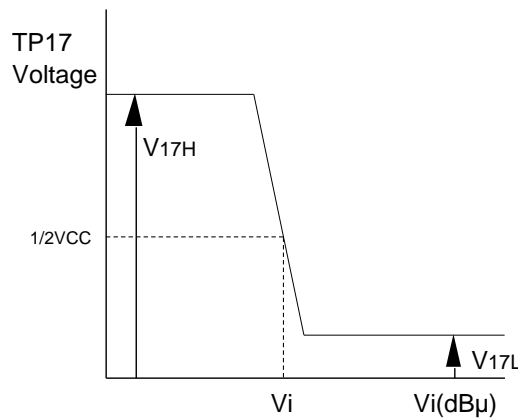

7. Capture range: CL - U

1. Increase the frequency of SG9 until the VCO is out of locked-oscillation.
2. Decrease the frequency of SG9 and measure the frequency f_U when the VCO locks.

$$CL - U = f_U - 58.75 \quad [MHz]$$

8. Capture range: CL - L

1. Decrease the frequency of SG9 until the VCO is out of locked-oscillation.
2. Increase the frequency of SG9 and measure the frequency f_L when the VCO locks.

$$CL - L = 58.75 - f_L \quad [MHz]$$

9. Capture range: CL - T

$$CL - T = CL - U + CL - L \quad [MHz]$$

10. AFT sensitivity μ , Maximum AFT voltage V_{18H} , Minimum AFT voltage V_{18L}

1. Input SG10 into VIF IN , and set the frequency of SG10 so that the voltage of AFT output TP18 is 3[V] . This frequency is named f(3).
2. Set the frequency of SG10 so that the AFT output voltage is 2[V]. This frequency is named f(2)
3. IN the graph, maximum and minimum DC voltage are V_{18H} and V_{18L} , respectively.

$$\mu = \frac{1000 \text{ [mV]}}{f(2) - f(3) \text{ [kHz]}} \text{ [mV/kHz]}$$

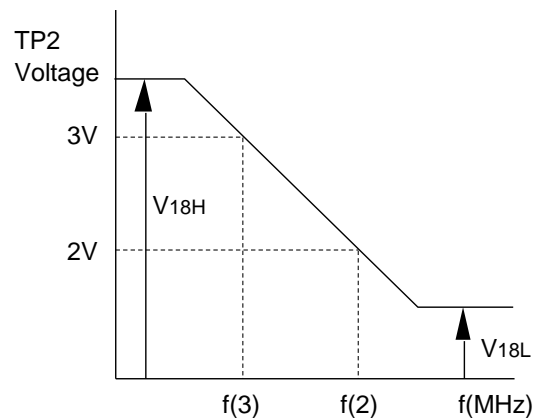

11. Inter modulation: IM

1. Input SG11 into VIF IN, and measure video output TP9 with an oscilloscope.
2. Adjust AGC filter voltage V23 so that the minimum DC level of the output waveform is 1.0V.
3. At this time, measure TP9 with a spectrum analyzer .
The inter modulation is defined as a difference between 0.92MHz and 3.58 MHz frequency components.

12. Limiting Sensitivity: LIM

1. Input SG17 (SG22) into SIF input, and measure the 400Hz component level of AF output TP14.
2. Input SG20 (SG25) into SIF input, and measure the 400Hz component level of AF output TP14 .
3. The input limiting sensitivity is defined as the input level when a difference between each 400Hz components of audio output (TP14) is 30dB, as shown below.

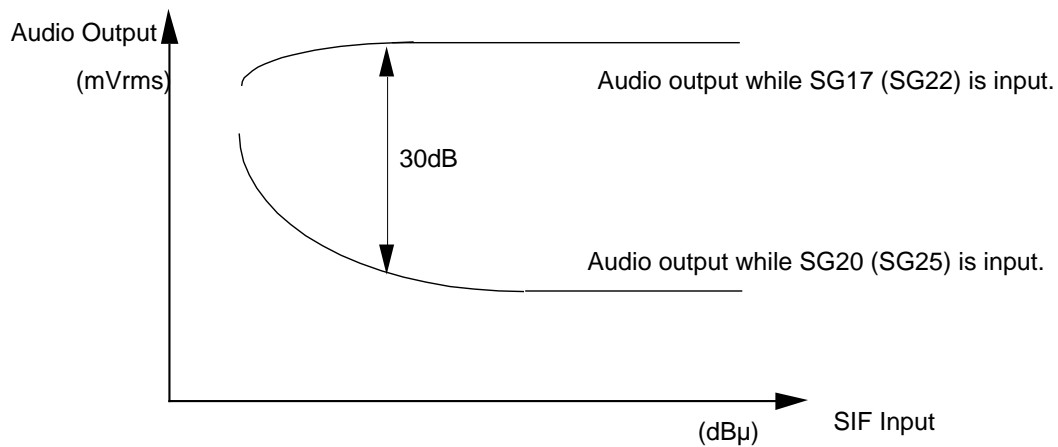
**13. AM Rejection: AMR**

1. Input SG18 (SG23) into SIF IN ,and measure the output level of Audio output (TP12). This level is named VAM.
2. AMR is;

$$AMR = 20 \log \left(\frac{V_{oAF} \text{ (mVr.m.s)}}{V_{AM} \text{ (mVr.m.s)}} \right) \quad [\text{dB}]$$

14. AF S/N: AF S/N

1. Input SG19 (SG24) into SIF input ,and measure the output noise level of Audio output (TP14). This level is named VN.
2. S/N is;

$$S/N = 20 \log \left(\frac{V_{oAF} \text{ (mVr.m.s)}}{V_N \text{ (mVr.m.s)}} \right) \quad [\text{dB}]$$

15. QIF Control : CqIF

Lower the voltage of V16 ,and measure the voltage of V16 when DC voltage of TP10 begins to change.

Structure of package (Cross section)

Structure

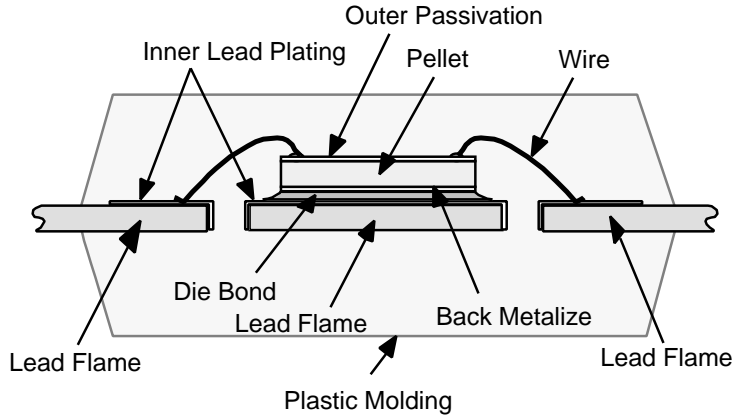

Matrrial	Mold resin	: Epoxy resin
	Internal lead	: Au wire (φ 25μm)
	External lead plating	: Solder plating
	Lead frame	: Copper alloy
	Passivation	: Nitride coat

Manufacturing place (Wafer process, assembly, final inspection)

Mitsubishi Electric Corporation Fukuoka Semiconductor Factory

Indications

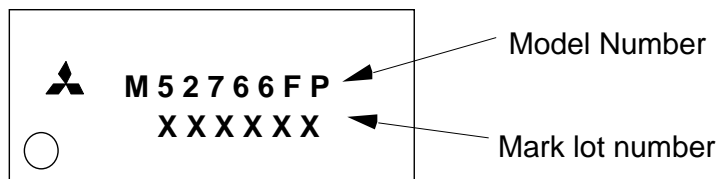

Lot number constitution

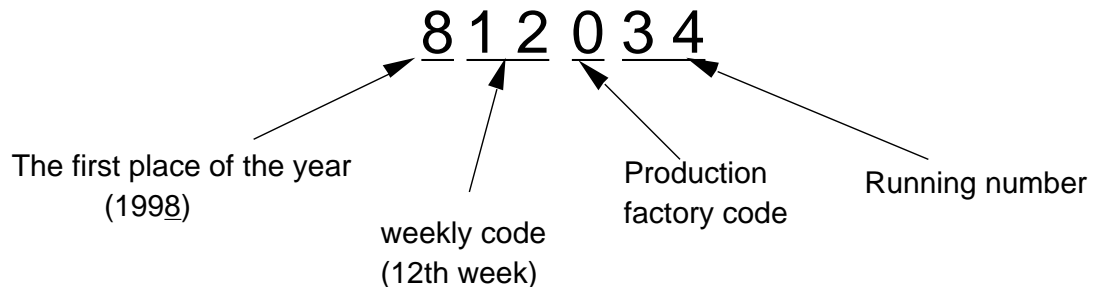

Package specification

IC package : 24P2Q

In case of tube shipping

Tube : 50 pieces / tube
 Interior box : 5000 pieces / interior box
 (100 tubes / interior box)
 Exterior box : 20000 pieces / exterior box
 (4 interior boxes / exterior box)

In case of emboss tape shipping
 (The direction of T1)

Reel : 2000 pieces / reel
 Interior box : 1 reel / interior
 Exterior box : 10000 pieces / exterior box
 (5 interior boxes / exterior box)

The packing method in case of tube shipping

1. Container tube

1.1 Container tube size

(1) IC tube MP016PC

A cross section

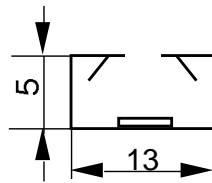

(2) Stopper plug

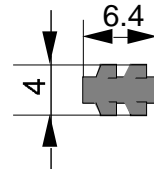

Width : 5.5
 Color : Gray

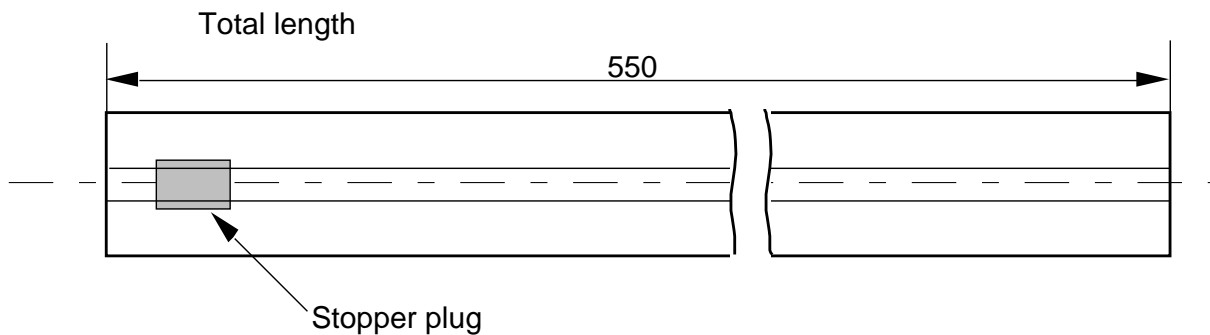

Unit : (mm)

1.2 Packing method

(1) The packing direction of the device.

(Facing the Pin No.1 with the marking side as shown below.)

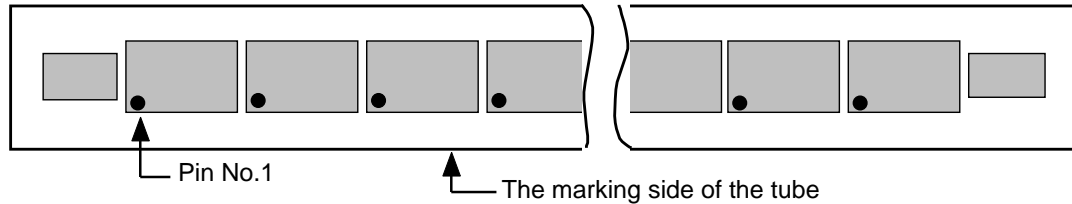

(2) The prevention of the vibration damage.

The stopper plug is pushed into the tube so that devices should not move and are kept plain condition.

Take care they do not warp.

(3) In case of a fraction

* In case IC number does not fill the typical accommodations, the stopper plug is used to fix devices.

* "PARTIAL" label is stuck on the fraction tube as shown below.

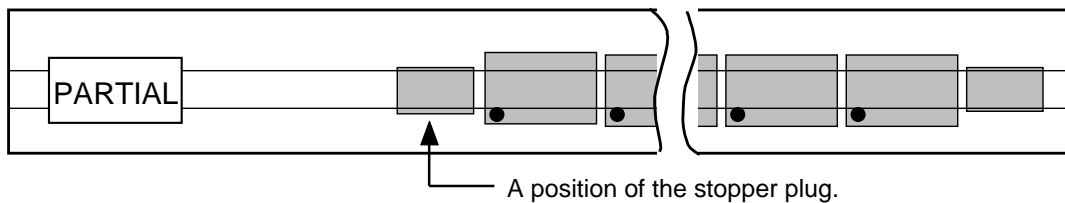

2. Interior box and exterior box

2.1 The arrangement of tubes in the interior box.

Nine lines and twelve steps

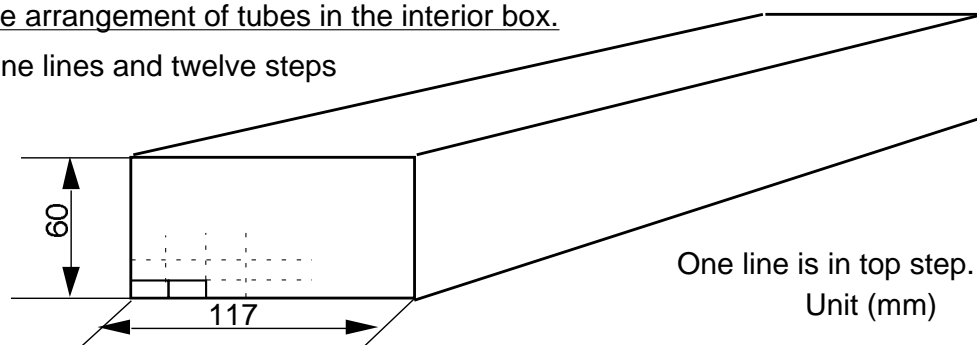

2.2 Damp proof packing

Use the specified PE bag and put a silica gel in it.

* Put the sealed interior box in a PE bag.

* Put the silica gel on the top step in the box.