



# KBPC6/BR6 SERIES

**SINGLE PHASE 6.0 AMPS.  
SILICON BRIDGE RECTIFIERS**

**Voltage Range  
50 to 1000 VOLTS  
Current  
6.0 Amperes**

**Features**

- UL Recognized File # E-230084
- High surge current capability
- Low forward voltage drop
- High temperature soldering guaranteed:  
250°C/10 seconds/.375" (9.5mm)  
lead lengths at 5 lbs. (2.3kg) tension
- Small size, simple installation
- Leads solderable per MIL-STD-202,  
Method 208

**KBPC6**

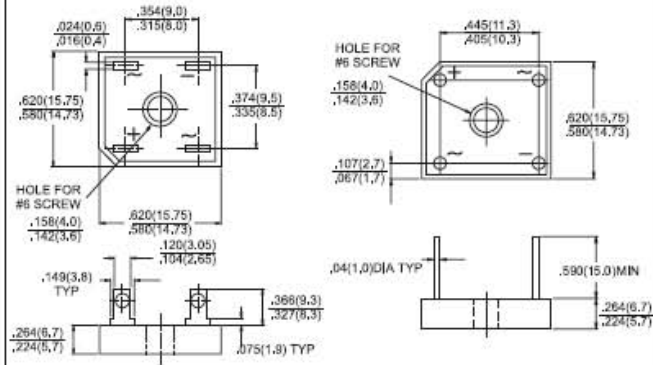

Dimensions in inches and (millimeters)

**MAXIMUM RATINGS AND ELECTRICAL CHARACTERISTICS**

Rating at 25°C ambient temperature unless otherwise specified.  
Single phase, half wave, 60Hz, resistive or inductive load.  
For capacitive load, derate current by 20%

Type Number		BR6005 KBPC6005	BR601 KBPC601	BR602 KBPC602	BR604 KBPC604	BR606 KBPC606	BR608 KBPC608	BR610 KBPC610	UNITS
Maximum Repetitive Peak Reverse Voltage	V <sub>RRM</sub>	50	100	200	400	600	800	1000	V
Maximum RMS Voltage	V <sub>RMS</sub>	35	70	140	280	420	560	700	V
Maximum DC Blocking Voltage	V <sub>DC</sub>	50	100	200	400	600	800	1000	V
Maximum Average Forward Rectified Current @T <sub>A</sub> = 50°C	I <sub>F(AV)</sub>	6.0							A
Peak Forward Surge Current, 8,3 ms Single Half Sine-wave Superimposed on Rated Load (JEDEC method)	I <sub>FSM</sub>	200							A
Maximum Instantaneous Forward Voltage Drop Per Leg @6.0A	V <sub>F</sub>	1.1							V
Maximun DC Reverse Current @ T <sub>A</sub> = 25°C at Rated DC Blocking Voltage @ T <sub>A</sub> = 100°C	I <sub>R</sub>	5 100							uA uA
Operating Temperature Range	T <sub>J</sub>	-55 to +125							°C
Storage Temperature Range	T <sub>STG</sub>	-55 to +150							°C

# RATING AND CHARACTERISTIC CURVES KBPC6/BR6 SERIES



FIG.1- MAXIMUM NON-REPEETITIVE FORWARD SURGE CURRENT PER BRIDGE ELEMENT

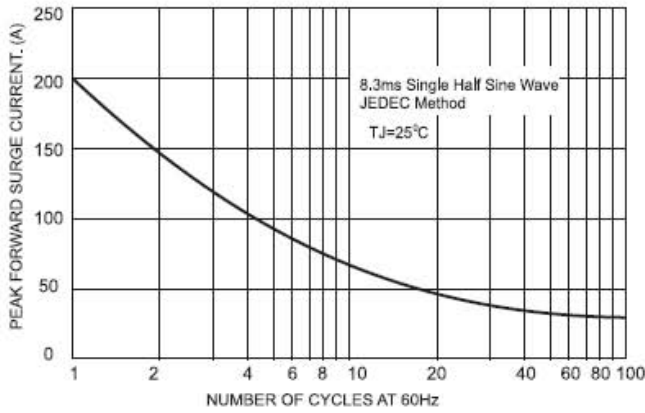

FIG.2- MAXIMUM FORWARD CURRENT DERATING CURVE

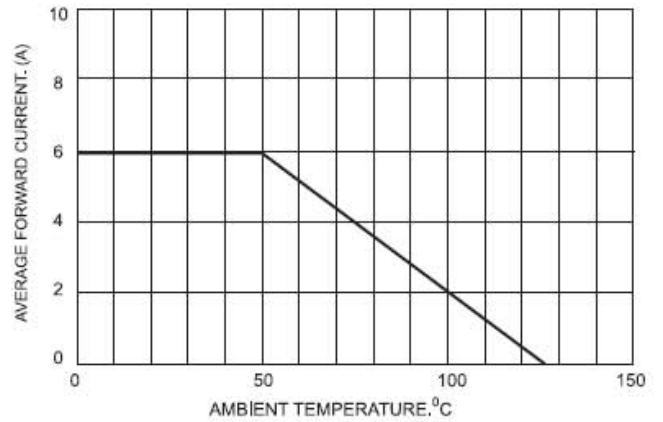

FIG.3- TYPICAL INSTANTANEOUS FORWARD CHARACTERISTICS PER BRIDGE ELEMENT

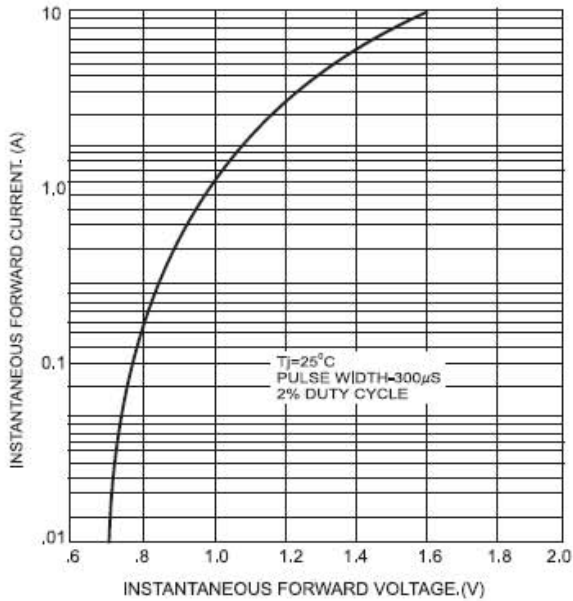

FIG.4- TYPICAL REVERSE CHARACTERISTICS PER BRIDGE ELEMENT

