

MCL4148

List

List..... 1

Package outline..... 2

Features..... 2

Mechanical data..... 2

Maximum ratings 2

Rating and characteristic curves..... 3

Pinning information..... 4

Marking..... 4

Suggested solder pad layout..... 4

Packing information..... 5

Reel packing..... 6

Suggested thermal profiles for soldering processes..... 6

High reliability test capabilities..... 7



Document ID	Issued Date	Revised Date	Revision	Page
DS-221903	2008/02/10	-	A	7

MCL4148

150mA Surface Mount Switching Diode- 100V

Features

- Fast speed switching.
- For general purpose switching application.
- High conductance.
- Hermetically sealed glass
- Silicon epitaxial planar chip.
- Lead-free parts meet RoHS requirements.

Mechanical data

- Case : GLASS MICRO-MELF
- Terminals : Solder plated, solderable per MIL-STD-750, Method 2026
- Polarity : Indicated by cathode band
- Mounting Position : Any
- Weight : Approximated 0.013 gram

Package outline

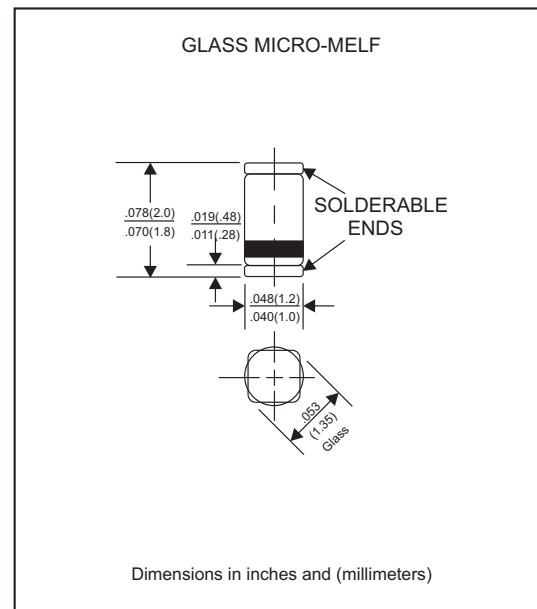

Maximum ratings and Electrical Characteristics (AT $T_A=25^\circ\text{C}$ unless otherwise noted)

PARAMETER	CONDITIONS	Symbol	MIN.	TYP.	MAX.	UNIT
Repetitive peak reverse voltage		V_{RRM}			100	V
Reverse voltage		V_R			75	V
Peak forward surge current	$t_p = 1 \text{ s}$	I_{FSM}			500	mA
Forward current		I_F			300	mA
Average forward current		I_{FAV}			150	mA
Power dissipation		P_V			500	mW
Junction temperature		T_J	-55		+150	$^\circ\text{C}$
Storage temperature		T_{STG}	-65		+150	$^\circ\text{C}$
Forward voltage	$I_F = 10 \text{ mA}$	V_F		0.86	1.00	V
Reverse current	$V_R = 20 \text{ V}$	I_R			25	nA
	$V_R = 20 \text{ V}, T_J = 150^\circ\text{C}$	I_R			50	μA
	$V_R = 75 \text{ V}$	I_R			5.0	μA
Diode capacitance	$V_R = 0 \text{ V}, f = 1\text{MHz}$	C_D			4.0	pF
Reverse recovery time	$I_F = 10 \text{ mA}, V_R = 6\text{V}, I_{RR} = 0.1 \times I_R, R_L = 100\Omega$	t_{rr}			4.0	ns

Rating and characteristic curves (MCL4148)

Fig.1 ADMISSIBLE REPETITIVE PEAK FORWARD CURRENT VERSUS PULSE DURATION

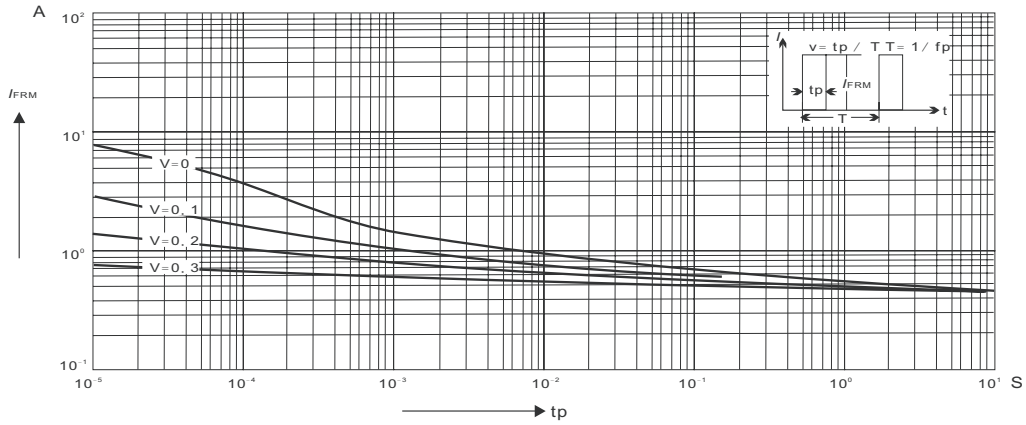

Fig.2-DYNAMIC FORWARD RESISTANCE VERSUS FORWARD CURRENT

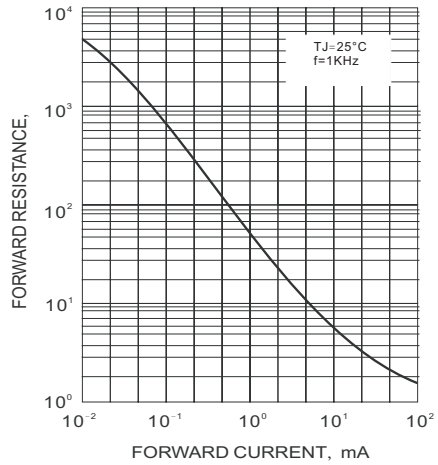

Fig.3 FORWARD CHARACTERISTICS

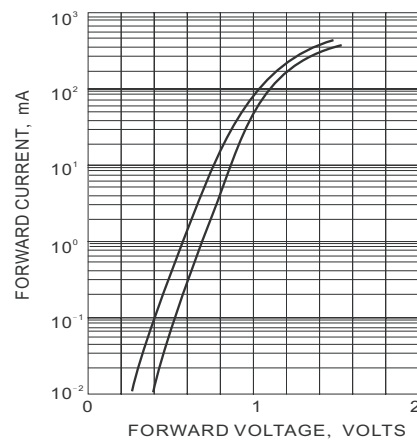

Fig.4 DERATING CURVE

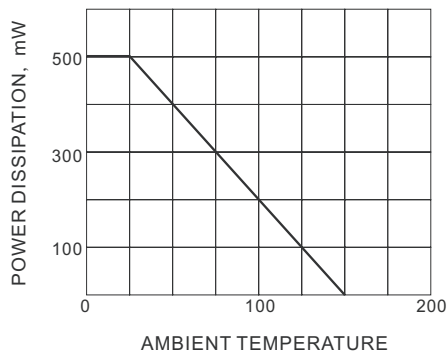
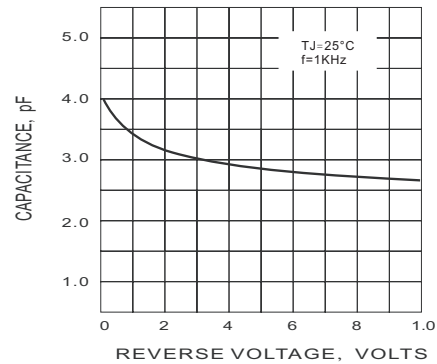

Fig.5 TYPICAL JUNCTION CAPACITANCE



MCL4148

Pinning information

Pin	Simplified outline	Symbol
Pin1 cathode Pin2 anode		

Marking

Type number	Marking code
MCL4148	cathode band only

Suggested solder pad layout

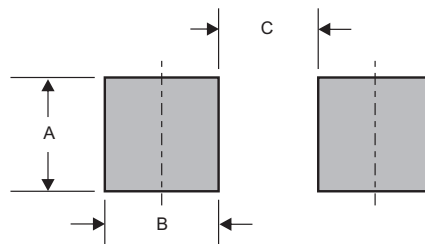

Dimensions in inches and (millimeters)

PACKAGE	A	B	C
MICRO-MELF	0.055(1.40)	0.024(0.60)	0.051(1.30)

MCL4148

Packing information

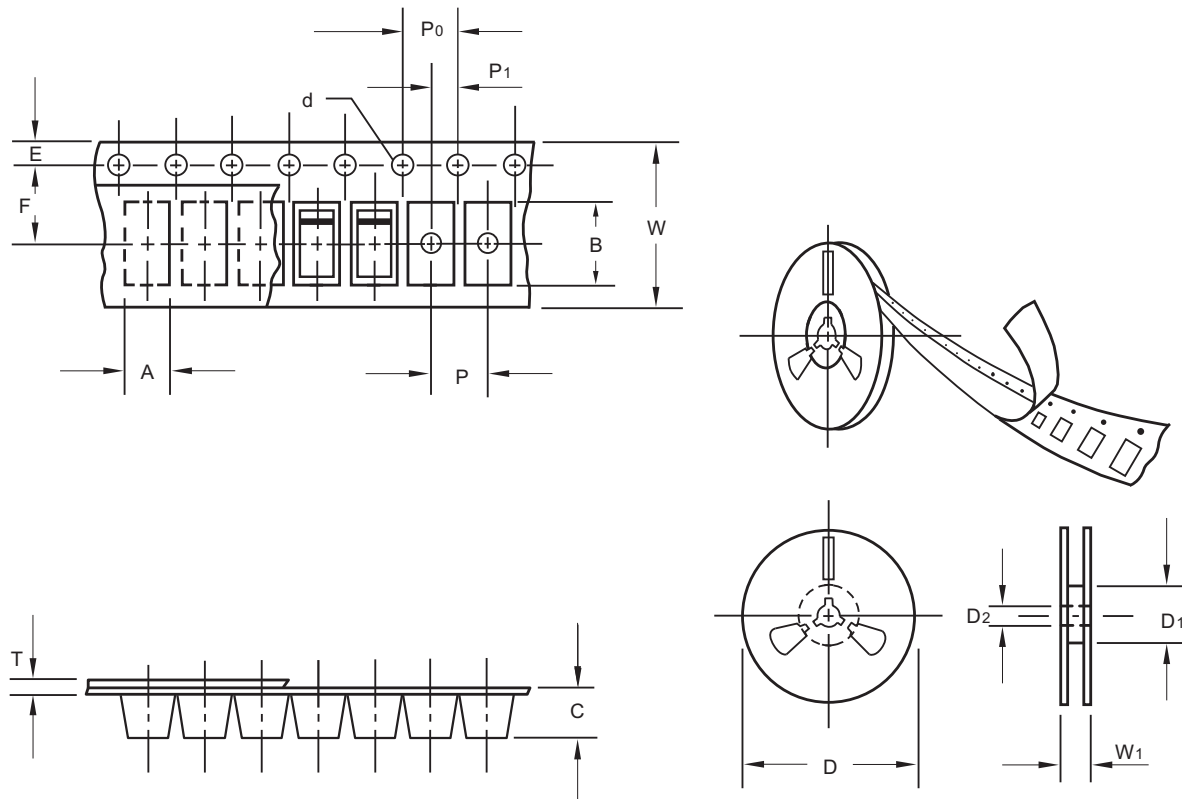

unit:mm

Item	Symbol	Tolerance	MICRO-MELF
Carrier width	A	0.1	2.00
Carrier length	B	0.1	3.70
Carrier depth	C	0.1	1.80
Sprocket hole	d	0.1	1.50
7" Reel outside diameter	D	2.0	178.00
7" Reel inner diameter	D ₁	min	50.00
Feed hole diameter	D ₂	0.5	13.00
Sprocket hole position	E	0.1	1.75
Punch hole position	F	0.1	3.50
Punch hole pitch	P	0.1	4.00
Sprocket hole pitch	P ₀	0.1	4.00
Embossment center	P ₁	0.1	2.00
Overall tape thickness	T	0.1	0.23
Tape width	W	0.3	8.00
Reel width	W ₁	0.1	11.40

Note: Devices are packed in accordance with EIA standard RS-481-A and specifications listed above.

MCL4148

Reel packing

PACKAGE	REEL SIZE	REEL (pcs)	COMPONENT SPACING (m/m)	BOX (pcs)	INNER BOX (m/m)	REEL DIA, (m/m)	CARTON SIZE (m/m)	CARTON (pcs)	APPROX. GROSS WEIGHT (kg)
GLASS MICRO -MELF	7"	2,500	4.0	25,000	183*183*123	178	382*262*387	200,000	9.6

Suggested thermal profiles for soldering processes

- 1.Storage environment: Temperature=5°C~40°C Humidity=55%±25%
- 2.Reflow soldering of surface-mount devices

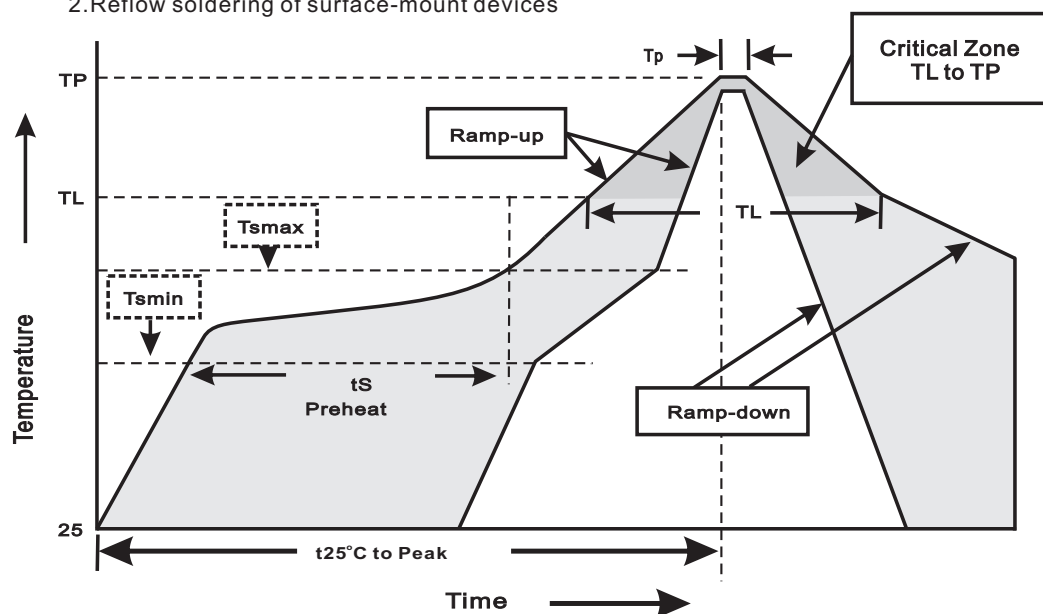

3.Reflow soldering

Profile Feature	Soldering Condition
Average ramp-up rate(T _L to T _P)	<3°C/sec
Preheat -Temperature Min(T _{smin}) -Temperature Max(T _{smax}) -Time(min to max)(t _s)	150°C 200°C 60~120sec
T _{smax} to T _L -Ramp-upRate	<3°C/sec
Time maintained above: -Temperature(T _L) -Time(t _L)	217°C 60~260sec
Peak Temperature(T _P)	255°C-0/+5°C
Time within 5°C of actual Peak Temperature(t _P)	10~30sec
Ramp-down Rate	<6°C/sec
Time 25°C to Peak Temperature	<6minutes

MCL4148**High reliability test capabilities**

Item Test	Conditions	Reference
1. Solder Resistance	at 260±5°C for 10±2sec. immerse body into solder 1/16"±1/32"	MIL-STD-750D METHOD-2031
2. Solderability	at 245±5°C for 5 sec.	MIL-STD-202F METHOD-208
3. High Temperature Reverse Bias	$V_R=80\%$ rate at $T_J=150^\circ\text{C}$ for 168 hrs.	MIL-STD-750D METHOD-1038
4. Forward Operation Life	Rated average rectifier current at $T_A=25^\circ\text{C}$ for 500hrs.	MIL-STD-750D METHOD-1027
5. Intermittent Operation Life	$T_A = 25^\circ\text{C}$, $I_F = I_O$ On state: power on for 5 min. off state: power off for 5 min. on and off for 500 cycles.	MIL-STD-750D METHOD-1036
6. Pressure Cooker	15P _{SIG} at $T_A=121^\circ\text{C}$ for 4 hrs.	JESD22-A102
7. Temperature Cycling	-55°C to +125°C dwelled for 30 min. and transferred for 5min. total 10 cycles.	MIL-STD-750D METHOD-1051
8. Thermal Shock	0°C for 5 min. rise to 100°C for 5 min. total 10 cycles.	MIL-STD-750D METHOD-1056
9. Forward Surge	Peak Forward Current $t_p = 1\text{s}$	MIL-STD-750D METHOD-4066-2
10. Humidity	at $T_A=85^\circ\text{C}$, RH=85% for 1000hrs.	MIL-STD-750D METHOD-1021
11. High Temperature Storage Life	at 175°C for 1000 hrs.	MIL-STD-750D METHOD-1031