

THIS COPY IS PROVIDED ON A RESTRICTED BASIS AND IS NOT TO BE USED IN ANY WAY DETRIMENTAL TO THE INTERESTS OF PANDUIT CORP.

PART NUMBER		TAB SIZE	WIRE RANGE AWG (mm ²)	DIMENSIONS in	
PREFIX	PK			A ^{±.03} (.8)	W ^{±.01} (.3)
D10-250M	-L -D	.250 X .032 (6.3 X 0.8)	12-10 (4.0-6.0)	.72 (18.3)	.25 (6.3)

NOTES:

- USED FOR:
A. STRANDED COPPER WIRE ONLY
- INSTALLATION TOOLS: CT-100, CT-200, CT-260, CT-570*, CT-1570*
- WIRE STRIP LENGTH: $9/32 \text{ }^{+1/32}_{-0}$ (7.1 $\text{ }^{+.8}_{-0}$)
- MATERIAL
A. STAMPING: .032 (.8) THICK NICKEL PLATED COPPER
- PACKAGING:
A. STD: -L = 50
B. BULK: -D = 500
- DIMENSIONS IN BRACKETS ARE IN MILLIMETERS OR mm²

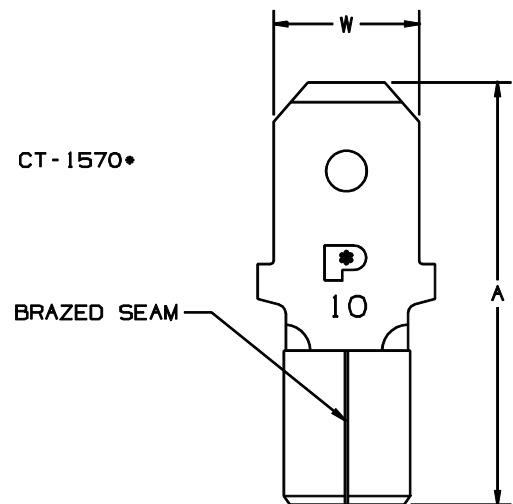

* APPROVED FOR USE WITH 14-10 AWG (2.5 - 6.0) WIRE WITH CT-570 & CT-1570 TOOLS

A41546_01

							PANDUIT CORP.		TINLEY PARK, ILLINOIS		
01	8/97	TM		WAS TIN PLATED, ADDED CT-1570 TOOL			12-10 .250 TAB NON-INSULATED MALE DISCONNECT				
00	9/92	BK	RS	RELEASED			01148	LA	JMO		
REV	DATE	BY	CHK	DESCRIPTION	ECN #	CUST	PM	DRAWN BY	CHK'D	SCALE	DRAWING NO./CAD FILENAME
								BDK		NONE	A41546