

5 BIT PROGRAMMABLE SYNCHRONOUS BUCK CONTROLLER IC WITH DUAL LDO CONTROLLER

FEATURES

- Meets Latest VRM 8.4 Specification for PIII
- Provides Single Chip Solution for Vcore, GTL+ and Clock Supply
- On board DAC programs the output voltage from 1.3V to 3.5V. The US3004/5 remains on for VID code of (11111).
- Dual linear regulator controller on board for 1.5V GTL+ and 2.5V clock supplies
- Loss less Short Circuit Protection
- Synchronous operation allows maximum efficiency
- Patented architecture allows fixed frequency operation as well as 100% duty cycle during dynamic load
- Min part count, No external Compensation
- Soft Start
- High current totem pole driver for direct driving of the external Power MOSFET
- Power Good function

APPLICATIONS

- Pentium III & next generation processor DC to DC converter application
- Low cost Pentium with AGP

DESCRIPTION

The US3004/5 series of controller ICs are specifically designed to meet Intel specification for Pentium III™ microprocessor applications as well as the next generation P6 family processors. **The IC provides a single chip controller IC for the Vcore, GTL+ and clock supplies required for the Pentium III applications.** These devices feature a patented topology that in combination with a few external components as shown in the typical application circuit, will provide in excess of 20A of output current for an on-board DC/DC converter while automatically providing the right output voltage via the 5 bit internal DAC meeting the latest VRM specification. These products also feature, **loss less current sensing by using the Rds-on of the high side Power MOSFET as the sensing resistor**, a Power Good window comparator that switches its open collector output low when the output is outside of a ±10% window. Other features of the device are; Undervoltage lockout for both 5V and 12V supplies, an external programmable soft start function as well as programming the oscillator frequency by using an external capacitor.

TYPICAL APPLICATION

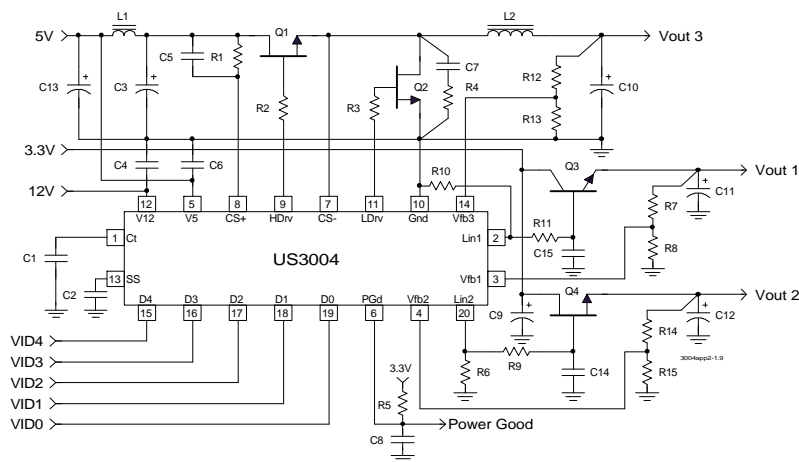

Notes: Pentium III is trade mark of Intel Corp.

PACKAGE ORDER INFORMATION

Ta (°C)	Device	Package	2.5V Output Voltage
0 TO 70	US3004CW	20 pin Plastic SOIC WB	Adjustable
0 TO 70	US3005CW	20 pin Plastic SOIC WB	Fixed

US3004,US3005

ABSOLUTE MAXIMUM RATINGS

V5 supply Voltage 10V
 V12 Supply Voltage 20V
 Storage Temperature Range -65 TO 150°C
 Operating Junction Temperature Range 0 TO 125°C

PACKAGE INFORMATION

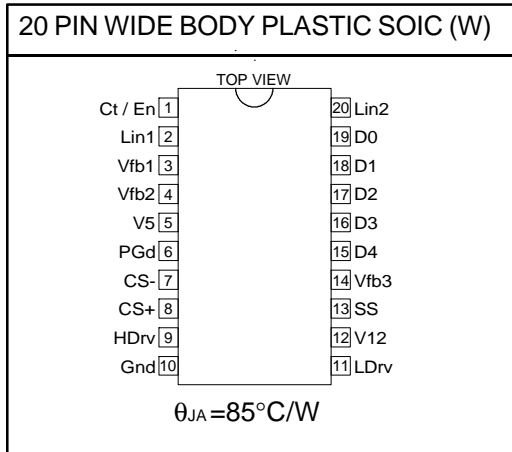

ELECTRICAL SPECIFICATIONS

Unless otherwise specified, these specifications apply over, $V_{12} = 12\text{V}$, $V_5 = 5\text{V}$ and $T_a = 0$ to 70°C . Typical values refer to $T_a = 25^{\circ}\text{C}$. Low duty cycle pulse testing are used which keeps junction and case temperatures equal to the ambient temperature.

PARAMETER	SYM	TEST CONDITION	MIN	TYP	MAX	UNITS
VID Section						
DAC output voltage (note 1)			0.99Vs	Vs	1.01Vs	V
DAC Output Line Regulation					0.1	%
DAC Output Temp Variation					0.5	%
VID Input LO					0.4	V
VID Input HI			2			V
VID input internal pull-up resistor to V5				27		k Ω
Power Good Section						
Under voltage lower trip point		Vout ramping down	0.89Vs	0.90Vs	0.91Vs	V
Under voltage upper trip point		Vout ramping up		0.92Vs		V
UV Hysterises			.015Vs	.02Vs	.025Vs	V
Over voltage upper trip point		Vout ramping up	1.09Vs	1.10Vs	1.11Vs	V
Over voltage lower trip point		Vout ramping down		1.08Vs		V
OV Hysterises			.015Vs	.02Vs	.025Vs	V
Power Good Output LO		RL=3mA			0.4	V
Power Good Output HI		RL=5K pull up to 5V	4.8			V
Soft Start Section						
Soft Start Current		CS+ =0V , CS- =5V		10		μA

UVLO Section						
UVLO Threshold-12V		Supply ramping up	9.2	10	10.8	V
UVLO Hysterises-12V			0.3	0.4	0.5	V
UVLO Threshold-5V		Supply ramping up	4.1	4.3	4.5	V
UVLO Hysterises-5V			0.2	0.3	0.4	V
Error Comparator Section						
Input bias current					2	uA
Input Offset Voltage			-2		+2	mV
Delay to Output		Vdiff=10mV			100	nS
Current Limit Section						
C.S Threshold Set Current			160	200	240	uA
C.S Comp Offset Voltage			-5		+5	mV
Hiccup Duty Cycle		Css=0.1 uF			2	%
Supply Current						
Operating Supply Current		CL=3000pF V5 V12		20 14		mA
Output Drivers Section						
Rise Time		CL=3000pF		70	100	nS
Fall Time		CL=3000pF		70	130	nS
Dead band Time		CL=3000pF	100	200	300	nS
Oscillator Section						
Osc Frequency		Ct=150pF	190	220	250	Khz
Osc Valley					0.2	V
Osc Peak				V5		V
LDO Controller Section						
Vfb1 & Vfb2 (US3004)			1.477	1.500	1.522	V
Vfb2 (US3005)						
Vfb1 (US3005)				2.500		V
Input bias current					2	uA
Lin1 or Lin2 Drive Current				50		mA

Note 1: Vs refers to the set point voltage given in Table 1.

D4	D3	D2	D1	D0	Vs
0	1	1	1	1	1.30
0	1	1	1	0	1.35
0	1	1	0	1	1.40
0	1	1	0	0	1.45
0	1	0	1	1	1.50
0	1	0	1	0	1.55
0	1	0	0	1	1.60
0	1	0	0	0	1.65
0	0	1	1	1	1.70
0	0	1	1	0	1.75
0	0	1	0	1	1.80
0	0	1	0	0	1.85
0	0	0	1	1	1.90
0	0	0	1	0	1.95
0	0	0	0	1	2.00
0	0	0	0	0	2.05

D4	D3	D2	D1	D0	Vs
1	1	1	1	1	2.0
1	1	1	1	0	2.1
1	1	1	0	1	2.2
1	1	1	0	0	2.3
1	1	0	1	1	2.4
1	1	0	1	0	2.5
1	1	0	0	1	2.6
1	1	0	0	0	2.7
1	0	1	1	1	2.8
1	0	1	1	0	2.9
1	0	1	0	1	3.0
1	0	1	0	0	3.1
1	0	0	1	1	3.2
1	0	0	1	0	3.3
1	0	0	0	1	3.4
1	0	0	0	0	3.5

Table 1 - Set point voltage vs. VID codes

US3004,US3005

PIN DESCRIPTIONS

PIN#	PIN SYMBOL	Pin Description
19	D0	LSB input to the DAC that programs the output voltage. This pin can be pulled up externally by a 10k resistor to either 3.3V or 5V supply.
18	D1	Input to the DAC that programs the output voltage. This pin can be pulled up externally by a 10k Ω resistor to either 3.3V or 5V supply.
17	D2	Input to the DAC that programs the output voltage. This pin can be pulled up externally by a 10k resistor to either 3.3V or 5V supply.
16	D3	MSB input to the DAC that programs the output voltage. This pin can be pulled up externally by a 10k resistor to either 3.3V or 5V supply.
15	D4	This pin selects a range of output voltages for the DAC. When in the LOW state the range is 1.3V to 2.05V. For VID codes of all "1" the US3004 keeps all the outputs on.
6	PGd	This pin is an open collector output that switches LO when the output of the converter is not within $\pm 10\%$ (typ) of the nominal output voltage. When PWRGD pin switches LO the sat voltage is less than 0.4V at 3mA.
14	Vfb3	This pin is connected directly to the output of the Core supply to provide feedback to the Error comparator.
8	CS+	This pin is connected to the Drain of the power MOSFET of the Core supply and it provides the positive sensing for the internal current sensing circuitry. An external resistor programs the C.S threshold depending on the Rds of the power MOSFET. An external capacitor is placed in parallel with the programming resistor to provide high frequency noise filtering.
7	CS-	This pin is connected to the Source of the power MOSFET for the Core supply and it provides the negative sensing for the internal current sensing circuitry.
13	SS	This pin provides the soft start for the switching regulator. An internal current source charges an external capacitor that is connected from this pin to the GND which ramps up the outputs of the switching regulator, preventing the outputs from overshooting as well as limiting the input current. The second function of the Soft Start cap is to provide long off time (HICCUP) for the synchronous MOSFET during current limiting.
1	Ct	This pin programs the oscillator frequency in the range of 50 kHz to 500kHz with an external capacitor connected from this pin to the GND.
2	Lin1	This pin controls the gate of an external transistor for either the GTL+ linear regulator or Clock supply.
3	Vfb1	This pin provides the feedback for the linear regulator that its output drive is Lin1 pin. For US3005, this pin is connected to the 2.5V regulator, eliminating the external dividers.
20	Lin2	This pin controls the gate of an external transistor for either the GTL+ linear regulator or Clock supply.
4	Vfb2	This pin provides the feedback for the linear regulator that its output drive is Lin2 pin.
10	Gnd	This pin serves as the ground pin and must be connected directly to the ground plane. A high frequency capacitor (0.1 to 1 uF) must be connected from V5 and V12 pins to this pin for noise free operation.
11	LDrv	Output driver for the synchronous power MOSFET.
9	HDrv	Output driver for the high side power MOSFET.
12	V12	This pin is connected to the 12 V supply and serves as the power Vcc pin for the output drivers. A high frequency capacitor (0.1 to 1 uF) must be connected directly from this pin to GND pin in order to supply the peak current to the power MOSFET during the transitions.
5	V5	5V supply voltage.

BLOCK DIAGRAM

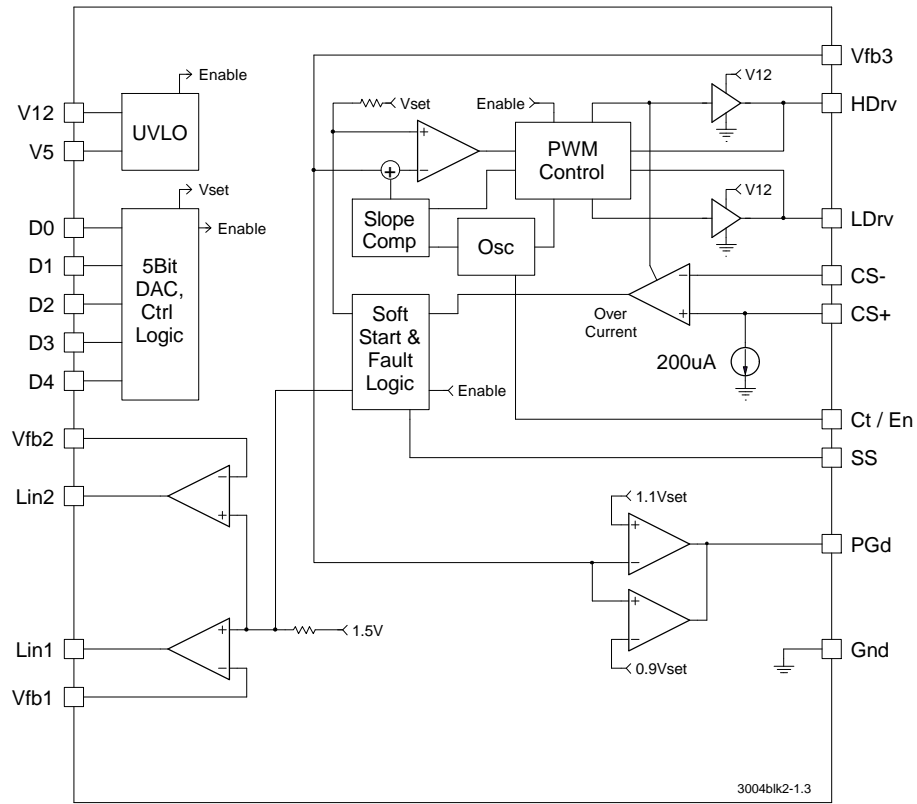

Figure 1 - Simplified block diagram of the US3004.

US3004,US3005

TYPICAL APPLICATION

Pentium III

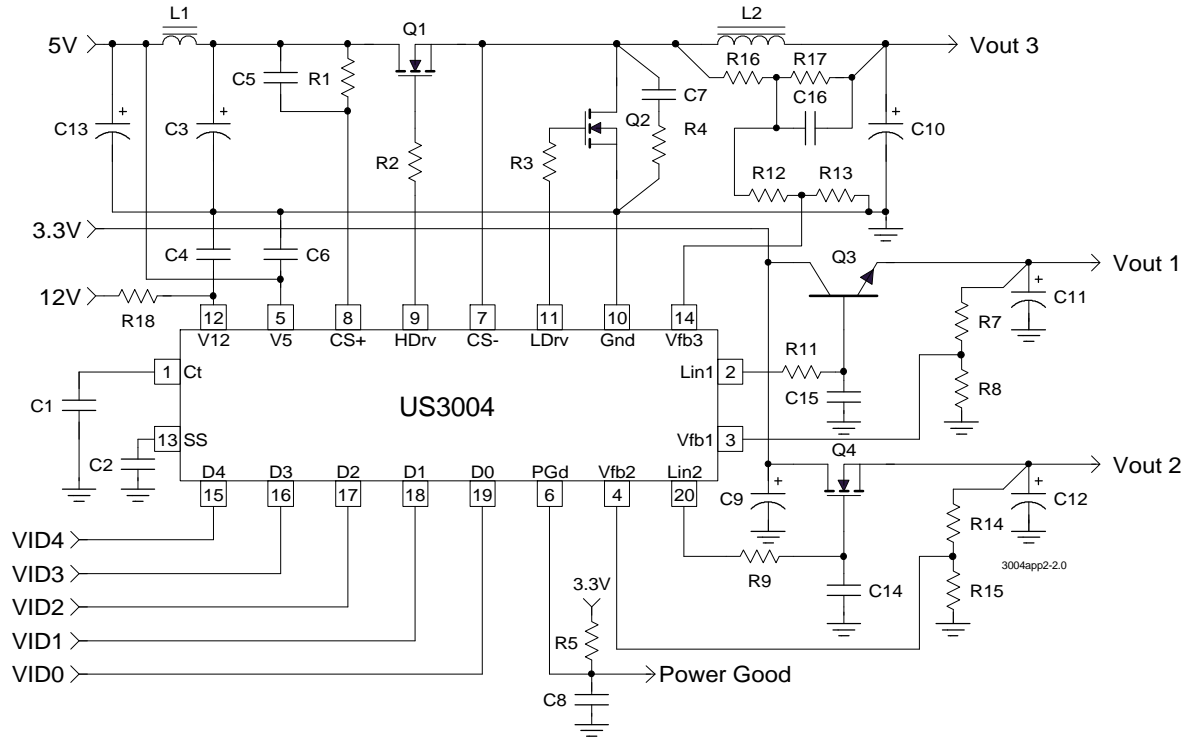

Figure 2- Typical application of US3004 or 3005 in an on board DC-DC converter providing the Core , GTL+, and Clock supplies for the Pentium II microprocessor.

PART #	R7 VALUE	R8 VALUE
US3004	SEE PARTS LIST	SEE PARTS LIST
US3005	SHORT	OPEN

Table2, describing the differences between 3004 and 3005 applications.

US3004/5 Application Parts List

Q1	MOSFET	1	IRL3103s, TO263 package	IR
Q2	MOSFET	1	IRL3103D1S, TO263 package	IR
Q3	Bipolar Trans, GP	1	MPS2222A, SOT23 package	MOT
Q4	MOSFET	1	IRLR024, TO252 package	IR
L1	Inductor	1	L=1uH, 5052 core with 4 turns of 1.0mm wire	Micro Metal
L2	Inductor	1	L=2.7uH, 5052B core with 7 turns of 1.2mm wire	Micro Metal
C1	Capacitor, Ceramic	1	150pF, 0603	
C2,6	Capacitor, Ceramic	2	1uF, 0603	
C3	Capacitor, Electrolytic	2	10MV1200GX, 1200uF,10V	Sanyo
C4	Capacitor, Ceramic	1	1uF, 0805	
C5	Capacitor, Ceramic	1	220pF, 0603	
C7,14,15	Capacitor, Ceramic	3	1000pF, 0603	
C8	Capacitor, Ceramic	1	0.1uF, 0603	
C9	Capacitor, Electrolytic	1	6MV1000GX, 1000uF,6.3V	Sanyo
C10	Capacitor, Electrolytic	6	6MV1500GX, 1500uF,6.3V	Sanyo
C11	Capacitor, Electrolytic	1	6MV150GX, 150uF,6.3V	Sanyo
C12	Capacitor, Electrolytic	1	6MV1000GX, 1000uF,6.3V	Sanyo
C13	Capacitor, Electrolytic	1	10MV470GX, 470uF,10V	Sanyo
C16	Capacitor, Ceramic	1	4.7uF, 1206	
R1	Resistor	1	3.3k Ω , 5%, 0603	
R2,3,4	Resistor	3	4.7 Ω , 5%, 1206	
R5,15	Resistor	2	10k Ω , 5%, 0603	
R7,12	Resistor	2	100 Ω , 1%, 0603	
R8	Resistor	1	150 Ω , 1%, 0603	
R9,11,14	Resistor	3	100 Ω , 5%, 0603	
R13	Resistor	1	22k Ω , 1%, 0603	
R16	Resistor	1	220 Ω , 1%, 0603	
R17	Resistor	1	330 Ω , 1%, 0603	
R18	Resistor	1	10 Ω , 5%, 0603	

Note 1: R16, R17, C16, R12, and R13 set the Vcore 2% higher for level shift to reduce CPU Transient Voltage.

Note 2: R14 and R15 set the 1.5V approximately 1% higher to account for the trace resistance drop.

US3004, US3005

TYPICAL APPLICATION

Pentium with AGP

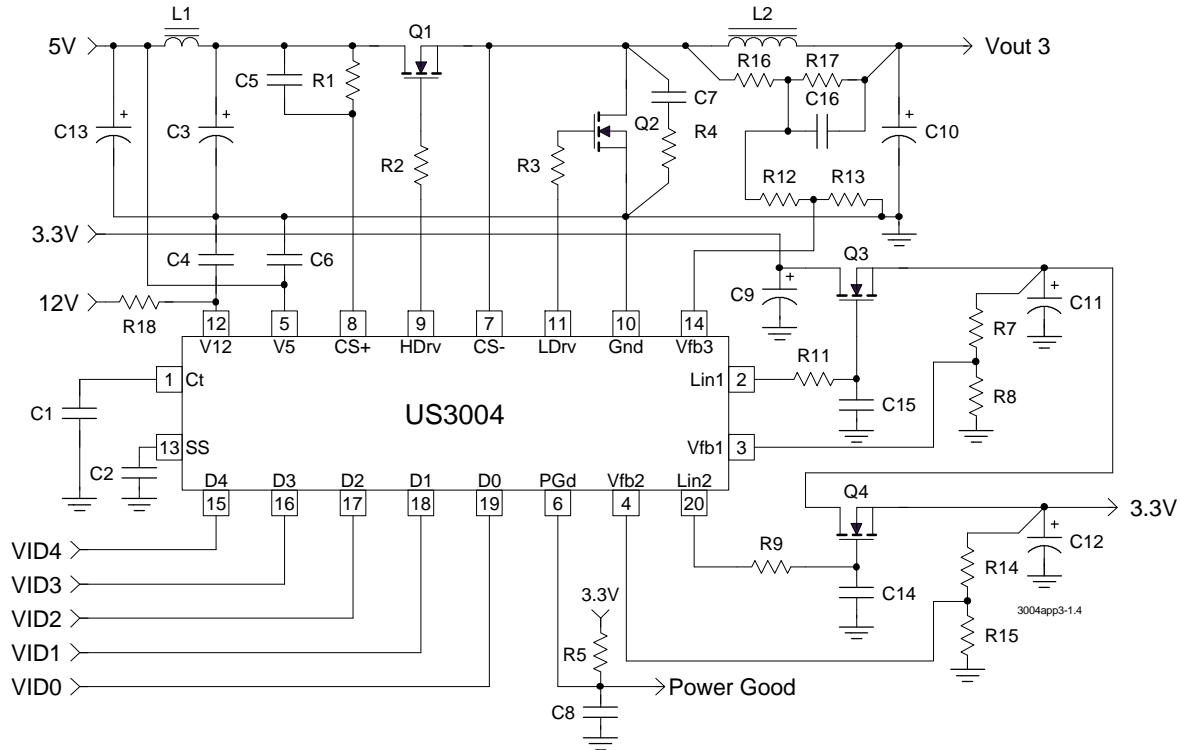

Figure 3- Typical application of US3004 in a Pentium with AGP where the power dissipation of the 3.3V linear regulator is equally distributed between Q3 and Q4 pass transistors. This equal distribution is possible by accurately regulating the first regulator using the US3004 linear controller and its internal 1% reference voltage while the second controller regulates the output of the first regulator from 4.17V to 3.3V, thereby distributing the power dissipation equally.

US3004 Application Parts List

Ref Desig	Description	Qty	Part #	Manuf
Q1	MOSFET	1	IRL3103s, TO263 package	IR
Q2	MOSFET	1	IRL3103D1S, TO263 package	IR
Q3,4	MOSFET	2	IRL3303S, TO263 package	IR
L1	Inductor	1	L=1uH, 5052 core with 4 turns of 1.0mm wire	Micro Metal
L2	Inductor	1	L=2.7uH, 5052B core with 7 turns of 1.2mm wire	Micro Metal
C1	Capacitor, Ceramic	1	150pF, 0603	
C2,6	Capacitor, Ceramic	2	1uF, 0603	
C3	Capacitor, Electrolytic	2	10MV1200GX, 1200uF,10V	Sanyo
C4	Capacitor, Ceramic	1	1uF, 0805	
C5	Capacitor, Ceramic	1	220pF, 0603	
C7,14,15	Capacitor, Ceramic	3	1000pF, 0603	
C8	Capacitor, Ceramic	1	0.1uF, 0603	
C9	Capacitor, Electrolytic	1	6MV1000GX, 1000uF,6.3V	Sanyo
C10	Capacitor, Electrolytic	6	6MV1500GX, 1500uF,6.3V,	Sanyo
C11	Capacitor, Electrolytic	1	6MV150GX, 150uF,6.3V	Sanyo
C12	Capacitor, Electrolytic	1	6MV1000GX, 1000uF,6.3V	Sanyo
C13	Capacitor, Electrolytic	1	10MV470GX, 470uF,10V	Sanyo
C16	Capacitor, Ceramic	1	4.7uF, 1206	
R1	Resistor	1	3.3k Ω , 5%, 0603	
R2,3,4	Resistor	3	4.7 Ω , 5%, 1206	
R5,15	Resistor	2	10k Ω , 5%, 0603	
R7	Resistor	1	267 Ω , 1%, 0603	
R8	Resistor	2	150 Ω , 1%, 0603	
R9,11,14	Resistor	3	100 Ω , 5%, 0603	
R12	Resistor	1	100 Ω , 1%, 0603	
R13	Resistor	1	22k Ω , 1%, 0603	
R16	Resistor	1	220 Ω , 1%, 0603	
R17	Resistor	1	330 Ω , 1%, 0603	
R18	Resistor	1	10 Ω , 5%, 0603	

Note 1: R16, R17, C16, R12, and R13 set the Vcore 2% higher for level shift to reduce CPU Transient Voltage.

Application Information

An example of how to calculate the components for the application circuit is given below.

Assuming, two sets of output conditions that this regulator must meet,

a) $V_o=2.8V$, $I_o=14.2A$, $\Delta V_o=185mV$, $\Delta I_o=14.2A$

b) $V_o=2V$, $I_o=14.2A$, $\Delta V_o=140mV$, $\Delta I_o=14.2A$

The regulator design will be done such that it meets the worst case requirement of each condition.

Output Capacitor Selection

The first step is to select the output capacitor. This is done primarily by selecting the maximum ESR value that meets the transient voltage budget of the total ΔV_o specification. Assuming that the regulators DC initial accuracy plus the output ripple is 2% of the output voltage, then the maximum ESR of the output capacitor is calculated as :

$$ESR \leq \frac{100}{14.2} = 7 \text{ m}\Omega$$

The Sanyo MVGX series is a good choice to achieve both the price and performance goals. The 6MV1500GX, 1500uF, 6.3V has an ESR of less than 36 m Ω typ. Selecting 6 of these capacitors in parallel has an ESR of ≈ 6 m Ω which achieves our low ESR goal.

Other type of Electrolytic capacitors from other manufacturers to consider are the Panasonic "FA" series or the Nichicon "PL" series.

Reducing the Output Capacitors Using Voltage Level Shifting Technique

The trace resistance or an external resistor from the output of the switching regulator to the Slot 1 can be used to the circuit advantage and possibly **reduce the number of output capacitors, by level shifting the DC regulation point when transitioning from light load to full load and vice versa**. To accomplish this, the output of the regulator is typically set about half the DC drop that results from light load to full load. For example, if the total resistance from the output capacitors to the Slot 1 and back to the GND pin of the device is 5m Ω and if the total ΔI , the change from light load to full load is 14A, then the output voltage measured at the top of the resistor divider which is also connected to the output capacitors in this case, must be set at half of the 70 mV or 35mV higher than the DAC voltage setting. This in

tentional voltage level shifting during the load transient eases the requirement for the output capacitor ESR at the cost of load regulation. One can show that the new ESR requirement eases up by **half the total trace resistance**. For example, if the ESR requirement of the output capacitors without voltage level shifting must be 7m Ω then after level shifting the new ESR will only need to be 9.5m Ω if the trace resistance is 5m Ω ($7+5/2=9.5$). However, one must be careful that the combined "voltage level shifting" and the transient response is still within the maximum tolerance of the Intel specification. To insure this, the maximum trace resistance must be less than:

$$R_s \leq 2(V_{\text{spec}} - 0.02 \cdot V_o - \Delta V_o) / \Delta I$$

Where :

R_s = Total maximum trace resistance allowed

V_{spec} = Intel total voltage spec

V_o = Output voltage

ΔV_o = Output ripple voltage

ΔI = load current step

For example, assuming:

$V_{\text{spec}} = \pm 140 \text{ mV} = \pm 0.14 \text{ V}$ for 2V output

$V_o = 2 \text{ V}$

$\Delta V_o = \text{assume } 10 \text{ mV} = 0.01 \text{ V}$

$\Delta I = 14.2 \text{ A}$

Then the R_s is calculated to be:

$$R_s \leq 2(0.140 - 0.02 \cdot 2 - 0.01) / 14.2 = 12.6 \text{ m}\Omega$$

However, if a resistor of this value is used, the maximum power dissipated in the trace (or if an external resistor is being used) must also be considered. For example if $R_s = 12.6 \text{ m}\Omega$, the power dissipated is $(I_o^2) \cdot R_s = (14.2^2) \cdot 12.6 = 2.54 \text{ W}$. This is a lot of power to be dissipated in a system. So, if the $R_s = 5 \text{ m}\Omega$, then the power dissipated is about 1W which is much more acceptable. If level shifting is not implemented, then the maximum output capacitor ESR was shown previously to be 7m Ω which translated to ≈ 6 of the 1500uF, 6MV1500GX type Sanyo capacitors. With $R_s = 5 \text{ m}\Omega$, the maximum ESR becomes 9.5m Ω which is equivalent to ≈ 4 caps. Another important consideration is that **if a trace is being used to implement the resistor, the power dissipated by the trace increases the case temperature of the output capacitors which could seriously effect the life time of the output capacitors**.

Output Inductor Selection

The output inductance must be selected such that under low line and the maximum output voltage condition, the inductor current slope times the output capacitor ESR is ramping up faster than the capacitor voltage is

drooping during a load current step. However if the inductor is too small, the output ripple current and ripple voltage become too large. One solution to bring the ripple current down is to increase the switching frequency, however that will be at the cost of reduced efficiency and higher system cost. The following set of formulas are derived to achieve the optimum performance without many design iterations.

The maximum output inductance is calculated using the following equation:

$$L = ESR * C * (V_{in\ min} - V_{om\ max}) / (2 * \Delta I)$$

Where:

$V_{in\ min}$ = Minimum input voltage

For $V_o = 2.8\text{ V}$, $\Delta I = 14.2\text{ A}$

$$L = 0.006 * 9000 * (4.75 - 2.8) / (2 * 14.2) = 3.7\ \mu\text{H}$$

Assuming that the programmed switching frequency is set at 200 KHZ, an inductor is designed using the Micrometals' powder iron core material. The summary of the design is outlined below:

The selected core material is Powder Iron, the selected core is T50-52D from Micro Metal wounded with 8 Turns of # 16 AWG wire, resulting in 3 uH inductance with $\approx 3\text{ m}\Omega$ of DC resistance.

Assuming $L = 3\ \mu\text{H}$ and the switching frequency; $f_{sw} = 200\text{ KHZ}$, the inductor ripple current and the output ripple voltage is calculated using the following set of equations:

$$T = 1/f_{sw}$$

$T \equiv$ Switching Period

$$D \approx (V_o + V_{sync}) / (V_{in} - V_{sw} + V_{sync})$$

$D \equiv$ Duty Cycle

$$T_{on} = D * T$$

$V_{sw} \equiv$ High side Mosfet ON Voltage = $I_o * R_{ds}$

$R_{ds} \equiv$ Mosfet On Resistance

$$T_{off} = T - T_{on}$$

$V_{sync} \equiv$ Synchronous MOSFET ON Voltage = $I_o * R_{ds}$

$$\Delta I_r = (V_o + V_{sync}) * T_{off} / L$$

$\Delta I_r \equiv$ Inductor Ripple Current

$$\Delta V_o = \Delta I_r * ESR$$

$\Delta V_o \equiv$ Output Ripple Voltage

In our example for $V_o = 2.8\text{V}$ and 14.2 A load, Assuming IRL3103 MOSFET for both switches with maximum on resistance of $19\text{ m}\Omega$, we have:

$$T = 1 / 200000 = 5\ \mu\text{Sec}$$

$$V_{sw} = V_{sync} = 14.2 * 0.019 = 0.27\text{ V}$$

$$D \approx (2.8 + 0.27) / (5 - 0.27 + 0.27) = 0.61$$

$$T_{on} = 0.61 * 5 = 3.1\ \mu\text{Sec}$$

$$T_{off} = 5 - 3.1 = 1.9\ \mu\text{Sec}$$

$$\Delta I_r = (2.8 + 0.27) * 1.9 / 3 = 1.94\text{ A}$$

$$\Delta V_o = 1.94 * .006 = .011\text{ V} = 11\text{ mV}$$

Power Component Selection

Assuming IRL3103 MOSFETs as power components, we will calculate the maximum power dissipation as follows:

For high side switch the maximum power dissipation happens at maximum V_o and maximum duty cycle.

$$D_{max} \approx (2.8 + 0.27) / (4.75 - 0.27 + 0.27) = 0.65$$

$$P_{dh} = D_{max} * I_o^2 * R_{ds(max)}$$

$$P_{dh} = 0.65 * 14.2^2 * 0.029 = 3.8\text{ W}$$

$R_{ds(max)}$ = Maximum R_{ds-on} of the MOSFET at 125°C

For synch MOSFET, maximum power dissipation happens at minimum V_o and minimum duty cycle.

$$D_{min} \approx (2 + 0.27) / (5.25 - 0.27 + 0.27) = 0.43$$

$$P_{ds} = (1 - D_{min}) * I_o^2 * R_{ds(max)}$$

$$P_{ds} = (1 - 0.43) * 14.2^2 * 0.029 = 3.33\text{ W}$$

Heatsink Selection

Selection of the heat sink is based on the maximum allowable junction temperature of the MOSFETS. Since we previously selected the maximum R_{ds-on} at 125°C , then we must keep the junction below this temperature. Selecting TO220 package gives $\theta_{jc} = 1.8^\circ\text{C/W}$ (From the vendors' datasheet) and assuming that the selected heatsink is Black Anodized, the Heat sink to Case thermal resistance is; $\theta_{cs} = 0.05^\circ\text{C/W}$, the maximum heat sink temperature is then calculated as:

$$T_s = T_j - P_d * (\theta_{jc} + \theta_{cs})$$

$$T_s = 125 - 3.82 * (1.8 + 0.05) = 118^\circ\text{C}$$

With the maximum heat sink temperature calculated in the previous step, the Heat Sink to Air thermal resistance (θ_{sa}) is calculated as follows:

Assuming $T_a = 35^\circ\text{C}$

$$\Delta T = T_s - T_a = 118 - 35 = 83^\circ\text{C} \quad \text{Temperature Rise}$$

Above Ambient

$$\theta_{sa} = \Delta T / P_d$$

$$\theta_{sa} = 83 / 3.82 = 22^\circ\text{C/W}$$

Next, a heat sink with lower θ_{sa} than the one calculated in the previous step must be selected. One way to do this is to simply look at the graphs of the "Heat Sink Temp Rise Above the Ambient" vs. the "Power Dissipation" given in the heatsink manufacturers' catalog and select a heat sink that results in lower temperature rise than the one calculated in previous step. The following heat sinks from Aavid and Thermalloy meet this criteria.

Co.	Part #
Thermalloy	6078B
AAVID	577002

US3004,US3005

Following the same procedure for the Schottky diode results in a heatsink with $\theta_{sa} = 25 \text{ }^\circ\text{C/W}$. Although it is possible to select a slightly smaller heatsink, for simplicity the same heatsink as the one for the high side MOSFET is also selected for the synchronous MOSFET.

Switcher Current Limit Protection

The PWM controller uses the MOSFET Rds-on as the sensing resistor to sense the MOSFET current and compares to a programmed voltage which is set externally via a resistor (Rcs) placed between the drain of the MOSFET and the "CS+" terminal of the IC as shown in the application circuit. For example, if the desired current limit point is set to be 22A and from our previous selection, the maximum MOSFET Rds-on=19m Ω , then the current sense resistor, Rcs is calculated as :

$$V_{cs} = I_{cL} * R_{ds} = 22 * 0.019 = 0.418\text{V}$$

$$R_{cs} = V_{cs} / I_b = (0.418\text{V}) / (200\mu\text{A}) = 2.1\text{k}\Omega$$

Where: $I_b = 200\mu\text{A}$ is the internal current setting of the device

Switcher Timing Capacitor Selection

The switching frequency can be programmed using an external timing capacitor. The value of C_t can be approximated using the equation below:

$$F_{sw} \approx \frac{3.5 \times 10^{-5}}{C_T}$$

Where :

$C_T = \text{Timing Capacitor}$

$F_{sw} = \text{Switching Frequency}$

If, $F_{sw} = 200 \text{ kHz}$:

$$C_T \approx \frac{3.5 \times 10^{-5}}{200 \times 10^3} = 175 \text{ pF}$$

LDO Power MOSFET Selection

The first step in selecting the power MOSFET for the linear regulators is to select its maximum Rds-on based on the input to output Dropout voltage and the maximum load current.

$$R_{ds}(\text{max}) = (V_{in} - V_o) / I_L$$

For $V_o = 1.5\text{V}$, and $V_{in} = 3.3\text{V}$, $I_L = 2\text{A}$

$$R_{ds}(\text{max}) = (3.3 - 1.5) / 2 = 0.9\Omega$$

Note that since the MOSFETs Rds-on increases with temperature, this number must be divided by ≈ 1.5 , in order to find the Rds-on max at room temperature. The Motorola MTP3055VL has a maximum of 0.18 Ω Rds-on at room temperature, which meets our requirement.

To select the heatsink for the LDO Mosfet the first step is to calculate the maximum power dissipation of the device and then follow the same procedure as for the switcher.

$$P_d = (V_{in} - V_o) * I_L$$

Where :

$P_d = \text{Power Dissipation of the Linear Regulator}$

$I_L = \text{Linear Regulator Load Current}$

For the 1.5V and 2A load:

$$P_d = (3.3 - 1.5) * 2 = 3.6 \text{ W}$$

Assuming $T_{j\text{-max}} = 125^\circ\text{C}$

$$T_s = T_j - P_d * (\theta_{jc} + \theta_{cs})$$

$$T_s = 125 - 3.6 * (1.8 + 0.05) = 118 \text{ }^\circ\text{C}$$

With the maximum heat sink temperature calculated in the previous step, the Heat Sink to Air thermal resistance (θ_{sa}) is calculated as follows :

Assuming $T_a = 35^\circ\text{C}$

$$\Delta T = T_s - T_a = 118 - 35 = 83 \text{ }^\circ\text{C} \quad \text{Temperature Rise}$$

Above Ambient

$$\theta_{sa} = \Delta T / P_d$$

$$\theta_{sa} = 83 / 3.6 = 23 \text{ }^\circ\text{C/W}$$

The same heat sink as the one selected for the switcher MOSFETs is also suitable for the 1.5V regulator. It is also possible to use TO263 package or even the MTD3055VL in D pak if the load current is less than 1.5A. For the 2.5V regulator since the dropout voltage is only 0.8V and the load current is less than 0.5A, for most applications the same MOSFET without heat sink or for low cost applications, one can use **PN2222A in TO92 or SOT23 package.**

LDO Regulator Component Selection

Since the internal voltage reference for the linear regulators is set at 1.5V for all devices, there is no need to divide the output voltage for the 1.5V, GTL+ regulator. For the 2.5V, Clock supply the resistor dividers are selected per following:

$$V_o = (1 + R_t / R_b) * V_{ref}$$

Where:

$R_t = \text{Top resistor divider}$

$R_b = \text{Bottom resistor divider}$

$V_{ref} = 1.5\text{V typical}$

Assuming $R_t = 100\Omega$, for $V_o = 2.5\text{V}$

$$R_b = R_t / [(V_o / V_{ref}) - 1]$$

$$R_b = 100 / [(2.5 / 1.5) - 1] = 150\Omega$$

For 1.5V output, Rt can be shorted and Rb left open. However it is recommended to leave the resistor dividers as shown in the typical application circuit so that the output voltage can be adjusted higher to account for the trace resistance in the final board layout.

It is also recommended that an external filter to be added on the linear regulators to reduce the amount of the high frequency ripple at the output of the regulators. This can simply be done by the resistor capacitor combination as shown in the application circuit.

For US3005 that include the resistor dividers internally, Vfb1 can be directly connected to the output voltage without any external resistors for a preset voltage of 2.5V. The disadvantage is that the output voltage is not adjustable anymore. The application circuit given for Pentium II can use either US3004 or US3005 family of parts for maximum flexibility.

Disabling the LDO Regulators

The LDO controllers can easily be disabled by connecting the feedback pins, Vfb1 and Vfb2 to a voltage higher than 2.5V such as 5V for all devices.

Switcher Output Voltage Adjust

As it was discussed earlier, the trace resistance from the output of the switching regulator to the Slot 1 can be used to the circuit advantage and possibly reduce the number of output capacitors, by level shifting the DC regulation point when transitioning from light load to full load and vice versa. To account for the DC drop, the output of the regulator is typically set about half the DC drop that results from light load to full load. For example, if the total resistance from the output capacitors to the Slot 1 and back to the GND pin of the part is $5\text{m}\Omega$ and if the total ΔI , the change from light load to full load is 14A, then the output voltage measured at the top of the resistor divider which is also connected to the output capacitors in this case, must be set at half of the 70 mV or 35mV higher than the DAC voltage setting. To do this, the top resistor of the resistor divider (R12 in the application circuit) is set at 100Ω , and the R13 is calculated. For example, if DAC voltage setting is for 2.8V and the desired output under light load is 2.835V, then R13 is calculated using the following formula :

$$R13 = 100 \cdot \left\{ \frac{V_{dac}}{(V_o - 1.004 \cdot V_{dac})} \right\} \quad [\Omega]$$

$$R13 = 100 \cdot \left\{ \frac{2.8}{(2.835 - 1.004 \cdot 2.800)} \right\} = 11.76 \text{ k}\Omega$$

Select 11.8 k Ω , 1%

Note: The value of the top resistor must not exceed 100 Ω . The bottom resistor can then be adjusted to raise the output voltage.

Soft Start Capacitor Selection

The soft start capacitor must be selected such that during the start up when the output capacitors are charging up, the peak inductor current does not reach the current limit threshold. A minimum of 1 μF capacitor insures this for most applications. An internal 10 μA current source charges the soft start capacitor which slowly ramps up the inverting input of the PWM comparator Vfb3. This insures the output voltage to ramp at the same rate as the soft start cap thereby limiting the input current. For example, with 1 μF and the 10 μA internal current source the ramp up rate is $(\Delta V / \Delta t) = I / C = 1\text{V} / 100\text{mS}$. Assuming that the output capacitance is 9000 μF , the maximum start up current will be:

$$I = 9000\mu\text{F} \cdot (1\text{V} / 100\text{mS}) = 0.09\text{A}$$

Input Filter

It is highly recommended to place an inductor between the system 5V supply and the input capacitors of the switching regulator to isolate the 5V supply from the switching noise that occurs during the turn on and off of the switching components. Typically an inductor in the range of 1 to 3 μH will be sufficient in this type of application.

Switcher External Shutdown

The best way to shutdown the switcher is to pull down on the soft start pin using an external small signal transistor such as 2N3904 or 2N7002 small signal MOSFET. This allows slow ramp up of the output, the same as the power up.

Layout Considerations

Switching regulators require careful attention to the layout of the components, specifically power components since they switch large currents. These switching components can create large amount of voltage spikes and high frequency harmonics if some of the critical components are far away from each other and are connected with inductive traces. The following is a guideline of how to place the critical components and the connections between them in order to minimize the above issues.

Start the layout by first placing the power components:

- 1) Place the input capacitors C3 and the high side mosfet ,Q1 as close to each other as possible
- 2) Place the synchronous mosfet,Q2 and the Q1 as close to each other as possible with the intention that the source of Q1 and drain of the Q2 has the shortest length.
- 3) Place the snubber R4 & C7 between Q1 & Q2.
- 4) Place the output inductor ,L2 and the output capacitors ,C10 between the mosfet and the load with output capacitors distributed along the slot 1 and close to it.
- 5) Place the bypass capacitors, C4 and C6 right next to 12V and 5V pins. C4 next to the 12V, pin 12 and C6 next to the 5V, pin 5.
- 6) Place the controller IC such that the pwm output drives, pins 9 and 11 are relatively short distance from gates of Q1 and Q2.
- 7) Place resistor dividers, R7 & R8 close to pin 3, R12 & R13 (note 1) close to pin 14 and R14 and R15 (note 1) close to pin 20.

Note 1: Although, the PWM controller does not require R12-15 resistors, and the feedback pins 3 and 14 can be directly connected to their respective outputs, they can be used to set the outputs slightly higher to account for any output drop at the load due to the trace resistance.

8) Place R11, C15, Q3 and C11 close to each other and do the same with R9, C14, Q4 and C12. Note: It is better to place the linear regulator components close to the IC and then run a trace from the output of each regulator to its respective load such as 2.5V to the clock and 1.5V for GTL + termination. However, if this is not possible then the trace from the linear drive output pins, pins 2 and 20 **must be routed away from any high frequency data signals.**

It is critical, to place high frequency ceramic capacitors close to the clock chip and termination resistors to provide local bypassing.

9) Place timing capacitor C1 close to pin1 and soft start capacitor C2 close to pin 13

Component connections:

Note : It is extremely important that no data bus should be passing through the switching regulator section specifically close to the fast transition nodes such as PWM drives or the inductor voltage.

Using the 4 layer board, dedicate on layer to GND, another layer as the power layer for the 5V, 3.3V, Vcore, 1.5V and if it is possible for the 2.5V.

Connect all grounds to the ground plane using direct vias to the ground plane.

Use large low inductance/low impedance plane to connect the following connections either using component side or the solder side.

- a) C3 to Q1 Drain
- b) Q1 Source to Q2 Drain
- c) Q2 drain to L2
- d) L2 to the output capacitors, C10
- e) C10 to the slot 1
- f) Input filter L1 to the C3
- g) C9 to Q4 drain
- h) C12 to the Q4 source

Connect the rest of the components using the shortest connection possible