

<b>GLASS PASSIVATED BRIDGE RECTIFIERS</b>	<b>REVERSE VOLTAGE - 50 to 1000Volts</b> <b>FORWARD CURRENT - 8.0 Amperes</b>
---	--

### FEATURES

- Surge overload rating -175 amperes peak
- Low forward voltage drop
- Small size; simple installation
- Silver plated copper leads
- Mounting position: Any

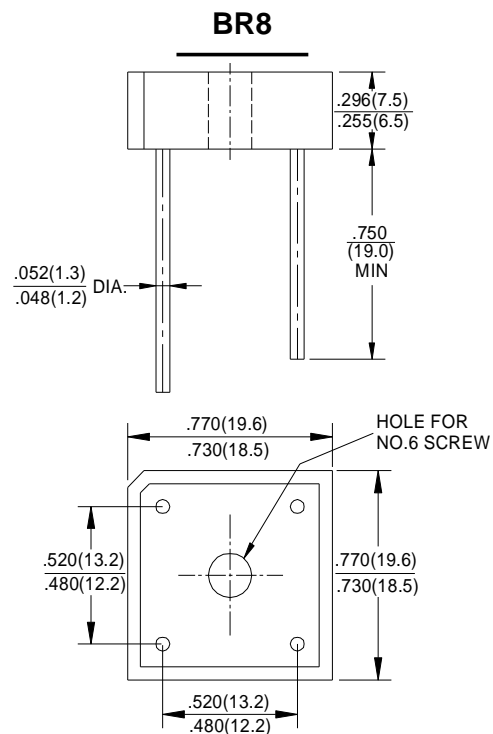

Polarity shown on side of case, Positive lead by beveled corner.

Dimensions in inches and (millimeters)

### MAXIMUM RATINGS AND ELECTRICAL CHARACTERISTICS

Rating at 25°C ambient temperature unless otherwise specified.

Single phase, half wave ,60Hz, resistive or inductive load.

For capacitive load, derate current by 20%

CHARACTERISTICS	SYMBOL	BR8005G	BR801G	BR802G	BR804G	BR806G	BR808G	BR810G	UNIT	
Maximum Recurrent Peak Reverse Voltage	VRRM	50	100	200	400	600	800	1000	V	
Maximum RMS Bridge Input Voltage	VRMS	30	70	140	280	420	560	700	V	
Maximum Average Forward Rectified Output Current at TC=100°C (Note1) TA=50°C (Note2)	I(AV)	8.0						3.0		A
Peak Forward Surge Current 8.3ms Single Half Sine-Wave Super Imposed on Rated Load	IFSM	175								A
Maximum Forward Voltage Drop Per Bridge Element at 4.0A Peak	VF	1.1								V
Maximum Reverse Current at Rated DC Blocking Voltage Per Element TA=25°C TA=100°C	IR	10.0						1.0		uA mA
Operating Temperature Range	TJ	-55 to +150								°C
Storage Temperature Range	TSTG	-55 to +150								°C

Notes: 1. Unit mounted on metal chassis

2. Unit mounted on P.C. board

FIG.1-DERATING CURVE FOR  
OUTPUT RECTIFIED CURRENT

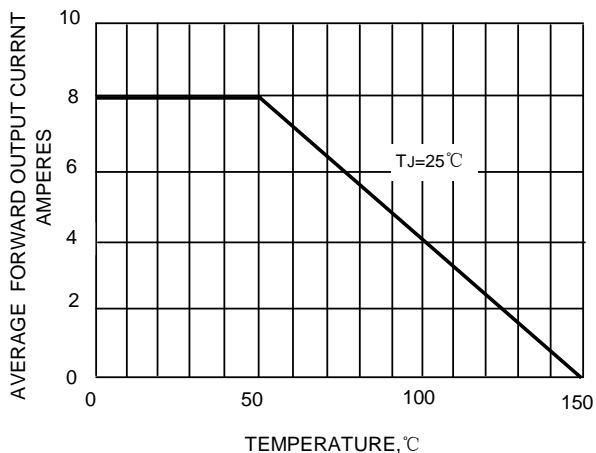

FIG.2-MAXIMUM FORWARD SURGE CURRENT

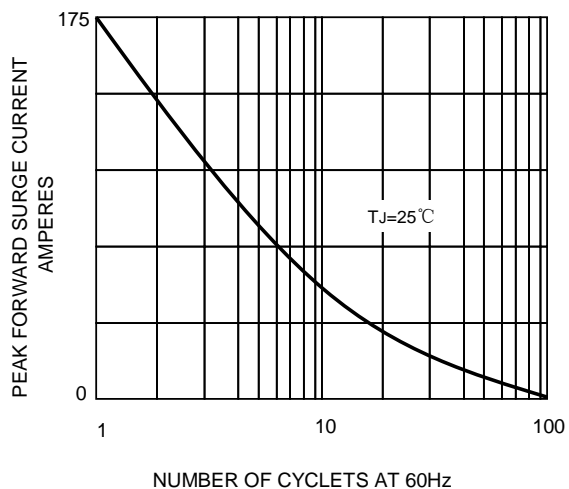

FIG.3-TYPICAL FORWARD  
CHARACTERISTICS

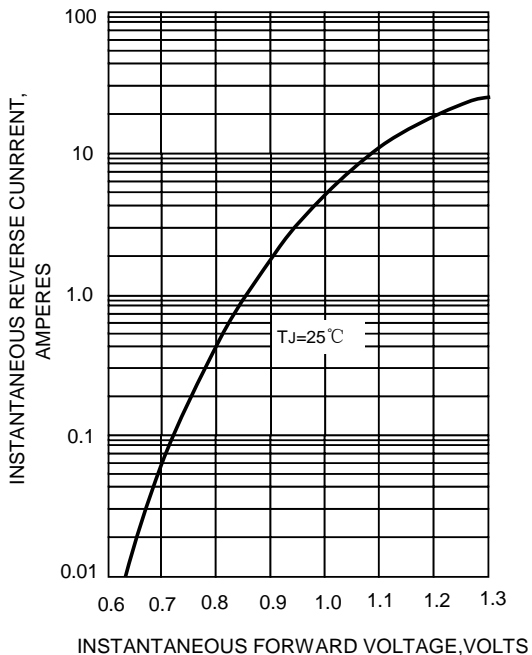

FIG.4-TYPICAL REVERSE  
CHARACTERISTICS

