

DESCRIPTION

The EV2108DQ/DK-00A is the evaluation board for the MP2108, a 2A, 720KHz synchronous buck converter designed for low voltage applications requiring high efficiency.

The MP2108 is capable of providing an output voltage as low as 0.9V and integrates top and bottom switches to minimize power loss and component count. The 720KHz switching frequency reduces the size of filtering components for a small solution size.

The MP2108 includes cycle-by-cycle current limiting and under voltage lockout. The 10-pin MSOP package is available on the EV2108DK-00A while the 10-pin 3mm x 3mm QFN package is available on the EV2108DQ-00A.

ELECTRICAL SPECIFICATIONS

Parameter	Symbol	Value	Units
Input Voltage	V_{IN}	2.6 – 6	V
Output Voltage	V_{OUT}	1.8	V
Output Current	I_{OUT}	2	A

FEATURES

- 2A Output Current
- Input Voltage Range of 2.6V to 6V
- Over 90% Efficiency

APPLICATIONS

- SOHO Routers, PCMCIA Cards, Mini PCI
- Handheld Computers, PDAs
- Cell phones, Digital Still and Video Cameras
- Small LCD Displays

"MPS" and "The Future of Analog IC Technology" are Registered Trademarks of Monolithic Power Systems, Inc.

EV2108DQ/DK-00A EVALUATION BOARD

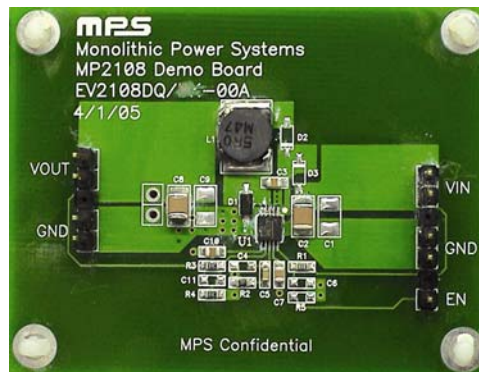

Dimensions (2.5"X x 2.0"Y x 0.5"Z)

Board Number	MPS IC Number
EV2108DQ/DK-00A	MP2108DQ/DK

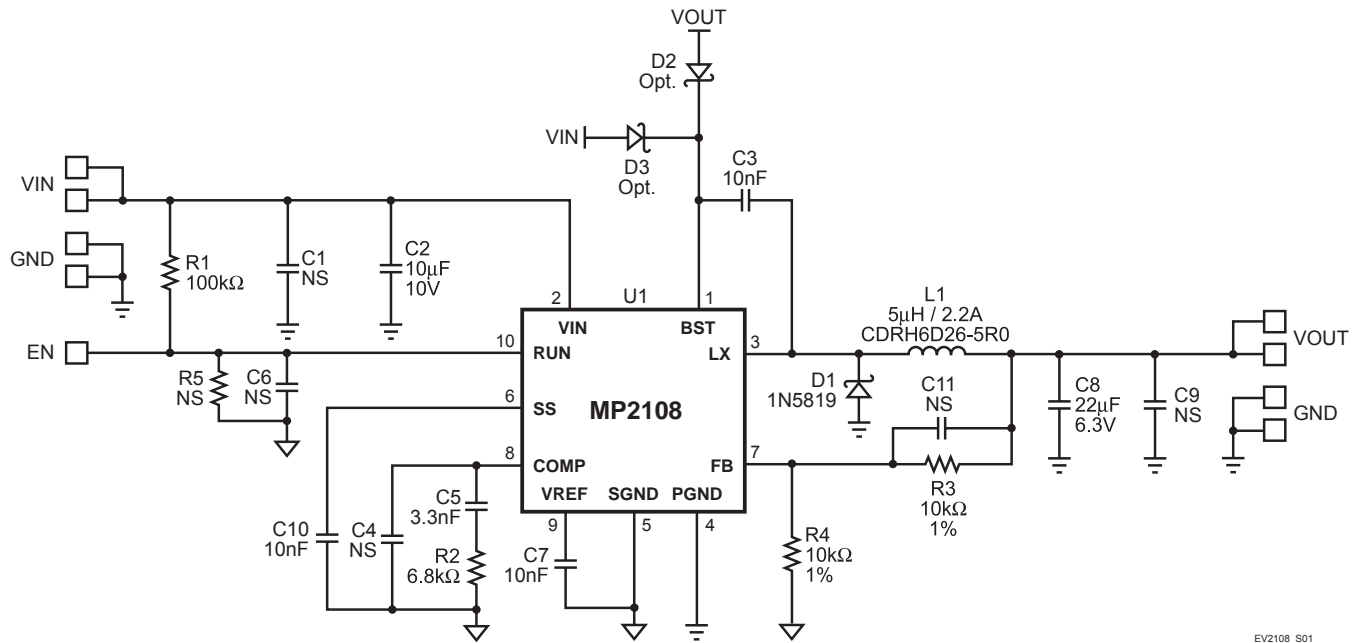
EVALUATION BOARD SCHEMATIC

EV2108_S01

EV2108DQ/DK-00A BILL OF MATERIALS

Qty	Ref	Value	Description	Package	Manufacturer	Manufacturer P/N
5	C1, C4, C6, C9, C11	NS	Not Stuffed			
1	C2	10 μ F	Ceramic Cap, 10V, X5R	SM1210	TDK	C3225X5R1A106K
3	C3, C7, C10	10nF	Ceramic Cap, 50V, X7R	SM0805	TDK	C2012X7R1H103K
1	C5	3.3nF	Ceramic Cap, 50V, X7R	SM0805	Panasonic	ECJ-2VB1H332K
1	C8	22 μ F	Ceramic Cap, 6.3V, X5R	SM1210	TDK	C3225X5R0J226M
1	D1		Schottky Diode, 40V, 1A	SOD123	Diodes Inc	1N5819HW-7
2	D2, D3		Do Not Stuff			
1	L1	5 μ H	Inductor, 2.2A	SMD	Sumida	CDRH6D26-5R0
1	R1	100k Ω	Resistor, 5%	SM0805	Panasonic	ERJ-6GEYJ104V
1	R2	6.8k Ω	Resistor, 5%	SM0805	Panasonic	ERJ-6GEYJ682V
2	R3, R4	10k Ω	Resistor, 1%	SM0805	Panasonic	ERJ-6ENF1002V
1	R5	NS	Not Stuffed			
1	U1		DC-DC Converter	MSOP10/ QFN10	MPS	MP2108DQ/DK

PRINTED CIRCUIT BOARD LAYOUT

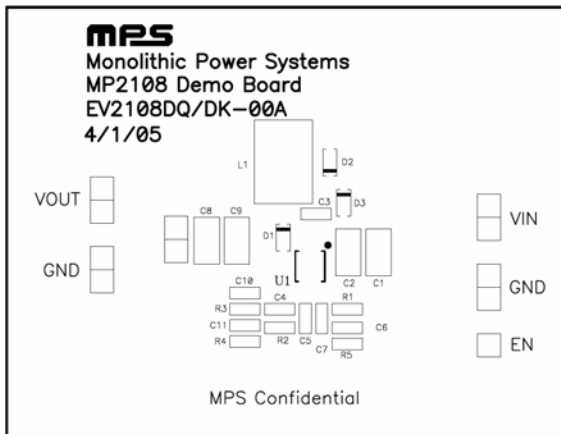

Figure 1—Top Silk Layer

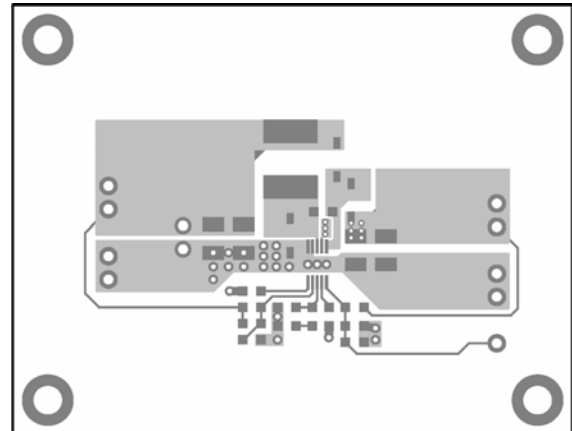

Figure 2—Top Layer

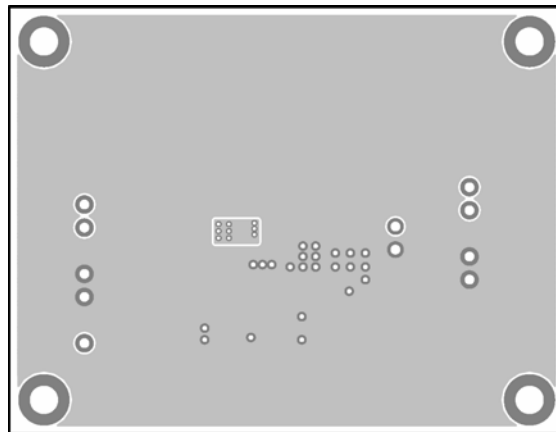

Figure 3—Bottom Layer

QUICK START GUIDE

The output voltage of this board is set to 1.8V. The board layout accommodates most commonly used inductors and output capacitors.

1. Attach the positive and negative ends of the load to the VOUT and GND pins, respectively.
2. Attach the input voltage ($2.6V \leq V_{IN} \leq 6V$) and input ground to the IN and GND pins, respectively.
3. A pull-up resistor has connected the RUN pin to the VIN pin, so the MP2108 will startup automatically without applying an external voltage to the RUN pin.
4. The output voltage V_{OUT} can be changed by varying R3. Calculate the new value using the formula:

$$R3 = R4 \times \left(\frac{V_{OUT}}{V_{FB}} - 1 \right)$$

where $V_{FB} = 0.9V$ and $R4 = 10k\Omega$.

For example, for $V_{OUT} = 2.5V$:

$$R3 = R4 \times \left(\frac{V_{OUT}}{V_{FB}} - 1 \right) = 10k\Omega \times \left(\frac{2.5V}{0.9V} - 1 \right) = 17.78k\Omega \sim 17.8k\Omega$$

for the closest standard 1% value.

See Maximum Duty Cycle limits to determine allowable output voltages.

The optional bootstrap diode (D3) may be added for improved efficiency.

NOTICE: The information in this document is subject to change without notice. Please contact MPS for current specifications. Users should warrant and guarantee that third party Intellectual Property rights are not infringed upon when integrating MPS products into any application. MPS will not assume any legal responsibility for any said applications.