



The Future of Analog IC Technology™

EV2101DQ-00A

1.6MHz, 800mA Synchronous Step-Down Converter plus 200mA LDO

EVALUATION BOARD

DESCRIPTION

The EV2101DQ-00A is the evaluation board for the MP2101 step-down converter. It is designed for high efficiency, step-down applications.

The MP2101 is a 1.6MHz current mode synchronous buck converter plus LDO, which provides two regulated output rails. Both control loops are internally compensated, and all power devices are integrated. Channel 1 is a synchronous buck providing up to 92% efficiency and 800mA output current from a 2.5V to 6V input voltage. Channel 2 is an LDO that can supply up to 200mA of load current from either the power input or the output of channel 1 to minimize the overall power loss and output noises.

The MP2101 is available in a space-saving 3mm x 3mm QFN10 package with an exposed pad.

FEATURES

- 0.8A and 0.2A Outputs
- 2.5V to 6V Operating Input Range
- Independently Adjustable Outputs from 0.6V to V_{IN}
- Independently External Enable Control
- PWROK Pin Monitors Output Regulation
- $\pm 3\%$ Output Voltage Reference Over Temperature
- Small Solution Size

APPLICATIONS

- DVD+/-RW drive
- Smart phones
- PDAs
- Digital Cameras
- Portable Instruments

"MPS" and "The Future of Analog IC Technology" are Trademarks of Monolithic Power Systems, Inc.

ELECTRICAL SPECIFICATIONS

Parameter	Symbol	Value	Units
Input Voltage Range	V_{IN}	2.5 – 6.0	V
Output Voltage	V_{OUT1}	1.8	V
	V_{OUT2}	1.2	V
Load Max	I_{OUT1}	800	mA
	I_{OUT2}	200	mA

EV2101DQ-00A EVALUATION BOARD



(L x W x H) 2.3" x 2.0" x 0.4"
(5.8cm x 5.1cm x 1.0cm)

Board Number	MPS IC Number
EV2101DQ-00A	MP2101DQ

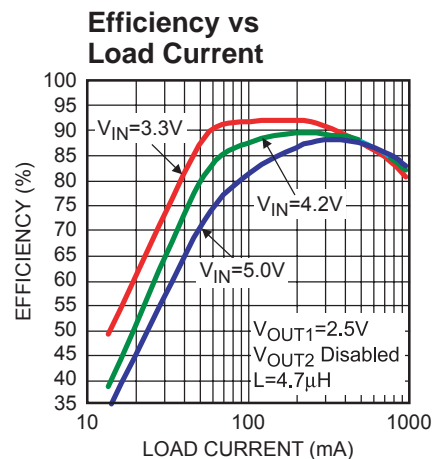

EVALUATION BOARD SCHEMATIC

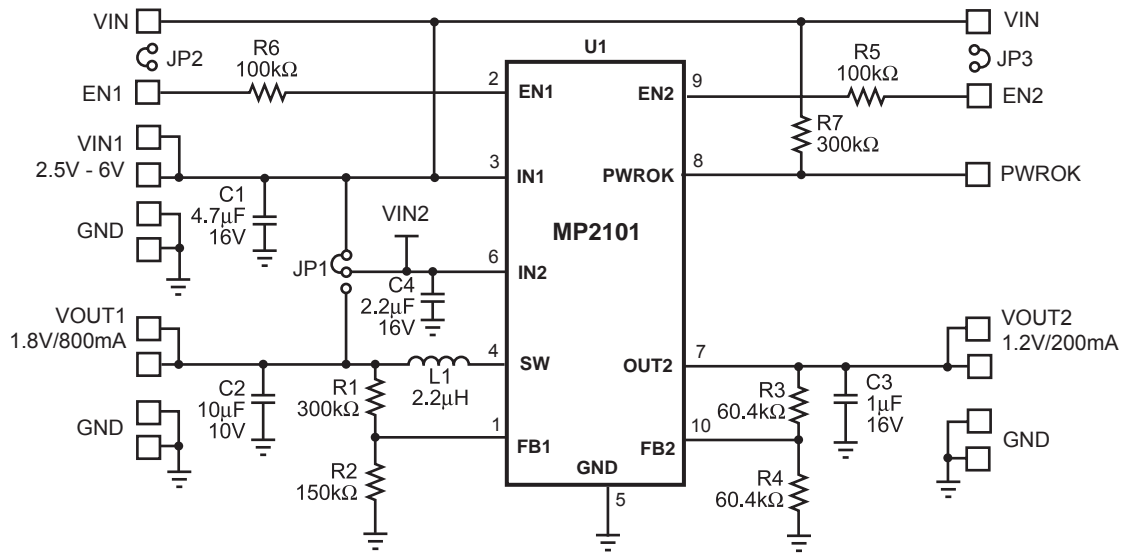

EV2101DQ-00A BILL OF MATERIALS

Qty	Ref	Value	Description	Package	Manufacturer	Manufacturer P/N
1	C1	4.7μF	Ceramic Cap., 16V, X7R	1206	TDK	C3216X7R1C475K
1	C2	10μF	Ceramic Cap., 10V, X5R	1210	TDK	C3225X5R1A106M
1	C3	1μF	Ceramic Cap., 16V, X7R	1206	TDK	C3216X7R1C105K
1	C4	2.2μF	Ceramic Cap., 16V, X7R	1206	TDK	C3216X7R1C225K
1	JP1		3-Pin Header, 0.1"		Sullins	PTC03SAAN
1	L1	2.2μH	D52LC Inductor, 1.63A	SMD	TOKO	A914BYW-2R2M
			CR32 Inductor, 1.28A	SMD	Sumida	CR32-2R2MC
2	R1, R7	300kΩ	Film Res., 1%	603	Yageo	9C06031A3003FKHFT
1	R2	150kΩ	Film Res., 1%	603	Panasonic	ERJ-3EKF1503V
2	R3, R4	60.4kΩ	Film Res., 1%	603	Panasonic	ERJ-3EKF6042V
2	R5, R6	100kΩ	Film Res., 5%	603	Panasonic	ERJ-3GEYJ104V
1	U1		DC-DC Converter	QFN10	MPS	MP2101DQ

TYPICAL PERFORMANCE CHARACTERISTICS

Enable Turn On

$V_{IN1} = V_{IN2} = 3.6V$, $V_{OUT1} = 1.8V$,
 $V_{OUT2} = 1.2V$, $EN1 = EN2 = 3.6V$
 $I_{LOAD1} = 0.3A$, $I_{LOAD2} = 0.1A$
 with Resistive Load

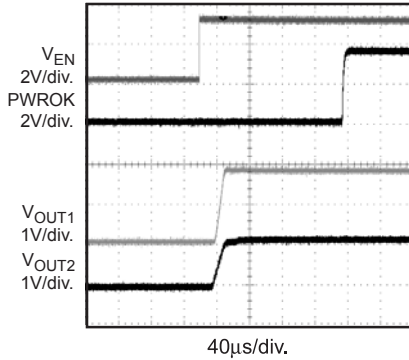

Enable Turn Off

$V_{IN1} = V_{IN2} = 3.6V$, $V_{OUT1} = 1.8V$,
 $V_{OUT2} = 1.2V$, $EN1 = EN2 = 3.6V$
 $I_{LOAD1} = 0.3A$, $I_{LOAD2} = 0.1A$
 with Resistive Load

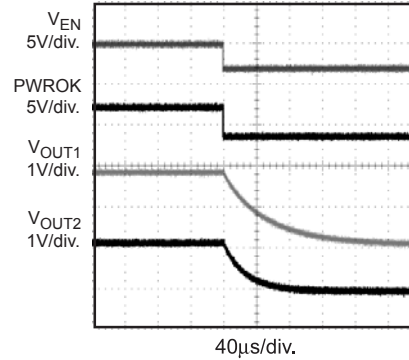

Input Ramp Up

$V_{IN1} = V_{IN2} = 3.6V$, $V_{OUT1} = 1.8V$,
 $V_{OUT2} = 1.2V$, $EN1 = EN2 = 3.6V$
 $I_{LOAD1} = 0.3A$, $I_{LOAD2} = 0.1A$
 with Resistive Load

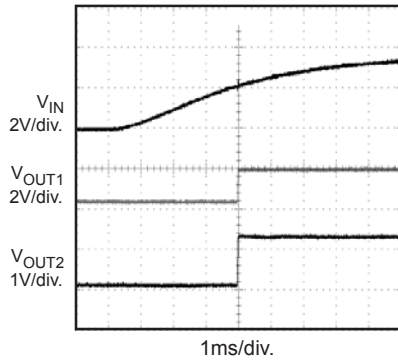

Input Ramp Down

$V_{IN1} = V_{IN2} = 3.6V$, $V_{OUT1} = 1.8V$,
 $V_{OUT2} = 1.2V$, $EN1 = EN2 = 3.6V$
 $I_{LOAD1} = 0.3A$, $I_{LOAD2} = 0.1A$
 with Resistive Load

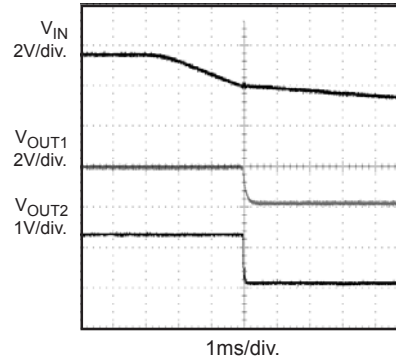

Load Transient of Synchronous Buck

$V_{IN} = 3.6V$, $V_{OUT1} = 1.8V$
 $I_{LOAD1} = 0.8A$ with Resistive Load

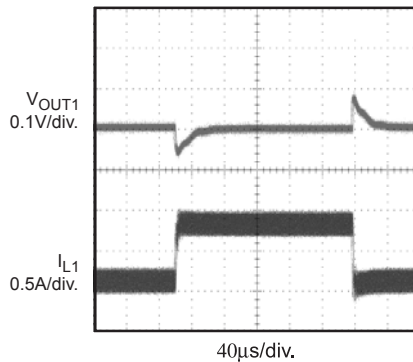

LDO Load Transient

$V_{IN} = V_{IN2} = 3.6V$, $V_{OUT2} = 1.2V$
 $I_{LOAD2} = 0.02A$ to $0.15A$
 with Resistive Load

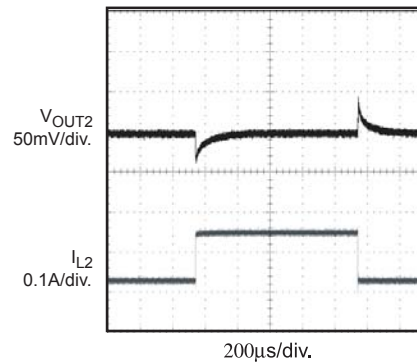

PRINTED CIRCUIT BOARD LAYOUT

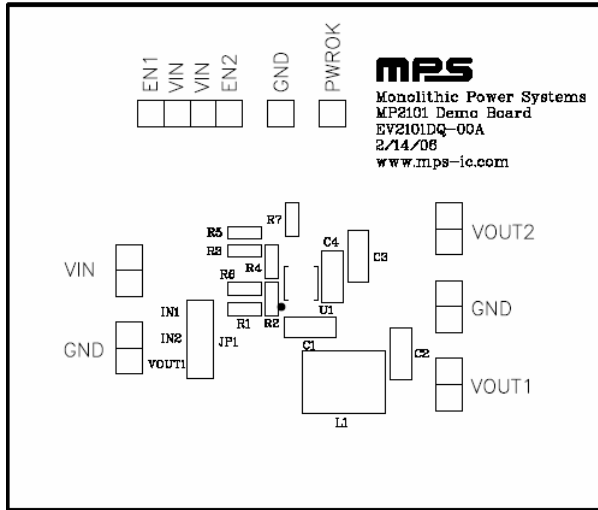

Figure 1—Top Silk Layer

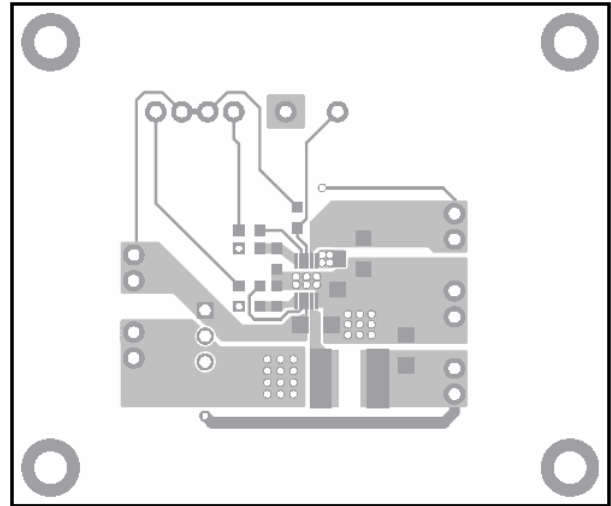

Figure 2—Top Layer

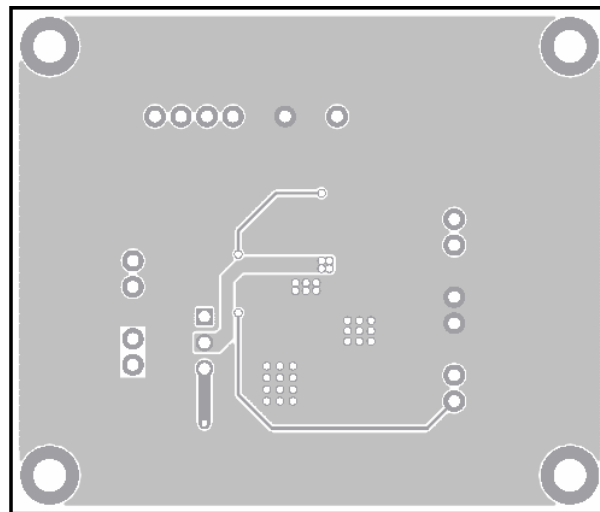

Figure 3—Bottom Layer

QUICK START GUIDE

The output voltages on this board are set to 1.8V and 1.2V. The board layout accommodates most commonly used inductors and output capacitors.

1. Attach the positive and negative ends of the load to the VOUT1/VOUT2 and GND pins, respectively.
2. With the input supply off, attach the input voltage, $2.5V \leq V_{IN} \leq 6V$, and the input ground to the VIN and GND pins, respectively. Then turn on the power supply.
3. To enable the MP2101, apply a voltage, $1.5V \leq V_{EN} \leq 6V$, to the EN1/EN2 pin. To disable the MP2101, apply a voltage, $V_{EN} < 0.3V$, to the EN1/EN2 pin. The default setting for the jumper on the board connects V_{IN} to the EN1/EN2 pin. In this configuration, the part will operate without applying any external voltage to the EN1/EN2 pin.
4. The output voltages V_{OUT1} and V_{OUT2} can be changed by varying R2 and R4, respectively. Calculate the new value by the formula:

$$R2 = \frac{R1}{\left(\frac{V_{OUT1}}{V_{FB1}}\right) - 1}$$

$$R4 = \frac{R3}{\left(\frac{V_{OUT2}}{V_{FB2}}\right) - 1}$$

Where $V_{FB1} = V_{FB2} = 0.6V$, $R1 = 300k\Omega$, and $R4 = 60.4k\Omega$

Example:

For $V_{OUT1} = 2.5V$:

$$R2 = \frac{300k\Omega}{\left(\frac{2.5V}{0.6V}\right) - 1} = 94.7k\Omega$$

Therefore, use a 95.3k Ω standard 1% value.

5. The JP1 Setting:

The JP1 can set the LDO input voltage from V_{IN1} or V_{OUT1} .

6. EN1/EN2 Setting: JP2 and JP3

The EN1/EN2 signals can be turned on by connecting to the input voltage V_{IN1} or an external signal.

NOTICE: The information in this document is subject to change without notice. Users should warrant and guarantee that third party Intellectual Property rights are not infringed upon when integrating MPS products into any application. MPS will not assume any legal responsibility for any said applications.