



The Future of Analog IC Technology™

# EV2000DJ-00A

## Low Input Voltage 150mA Linear Regulator Evaluation Board

### DESCRIPTION

The EV2000DJ-00A is the evaluation board for the MP2000DJ. The board operates from a 1.35V to 6.0V input voltage and regulates the output voltage at 1.2V with 2% accuracy. By adjusting the resistor divider values, the board can regulate the output voltage from 0.5V to 5V. It can also supply up to 150mA of load current.

### ELECTRICAL SPECIFICATIONS

Parameter	Symbol	Value	Units
Input Voltage	V <sub>IN</sub>	1.35 – 6.0	V
Output Voltage	V <sub>OUT</sub>	1.2	V
Operating Temperature		-40 – +85	°C

### FEATURES

- Excellent Load Transient Response
- Excellent Line Regulation
- 1.35V to 6V Input Voltage
- 1.2V Output Voltage
- Up to 150mA Load Current

### APPLICATIONS

- 802.11 PC Cards
- Mobile Handset PLL Power
- Audio Codec Power

"MPS" and "The Future of Analog IC Technology" are Trademarks of Monolithic Power Systems, Inc.

## EV2000DJ-00A EVALUATION BOARD



(L x W H) 2.0" x 2.0" x 0.4" (5.1cm x 5.1cm x 1.1cm)

Board Number	MPS IC Number
EV2000DJ-00A	MP2000DJ

**EVALUATION BOARD SCHEMATIC**

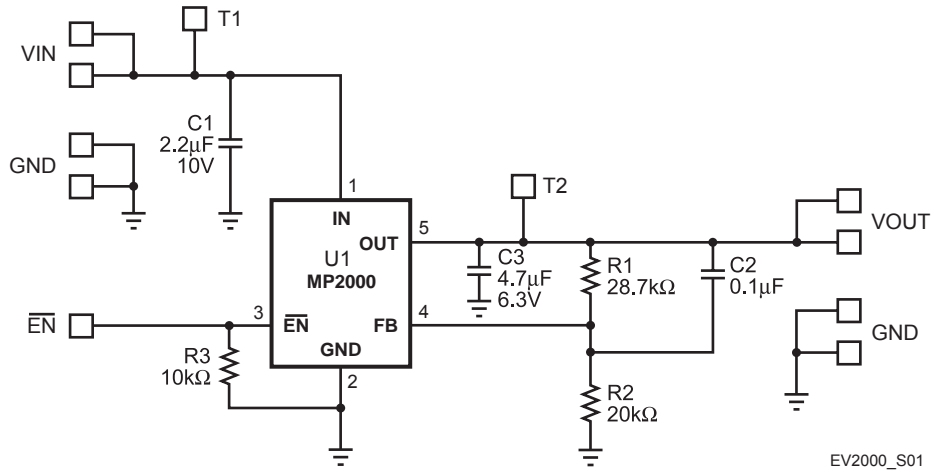

EV2000\_S01

**EV2000DJ-00A BILL OF MATERIALS**

Qty	Ref	Value	Description	Package	Manufacturer	Manufacturer P/N
1	C1	2.2µF	Ceramic Capacitor, 10V, X5R	0805	TDK	C2012X5R1A225K
1	C2	0.1µF	Ceramic Capacitor, 25V, X7R/X5R	0805	TDK	C2012X7R1E104K
1	C3	4.7µF	Ceramic Capacitor, 6.3V, X5R	0805	TDK	C2012X5R0J475K
1	R1	28.7kΩ	Resistor, 1%	0805	Panasonic	ERJ-6ENF4022V
1	R2	20.0kΩ	Resistor, 1%	0805	Panasonic	ERJ-6ENF4992V
1	R3	10kΩ	Resistor, 5%	0805	Panasonic	ERJ-6ENF1002V
1	U1		Low Voltage 150mA Linear Reg.	TSOT23-5	MPS	MP2000DJ

## PRINTED CIRCUIT BOARD LAYOUT

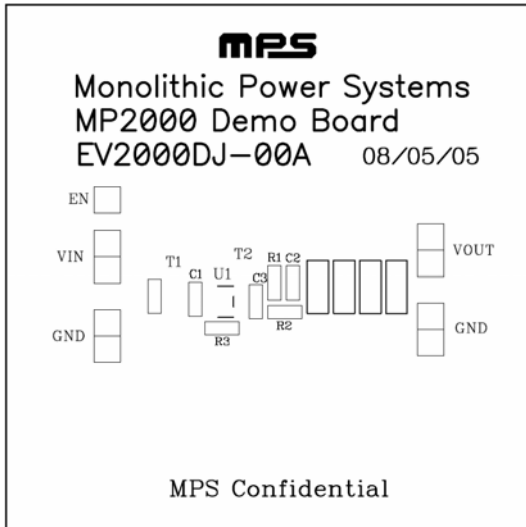

Figure 1—Top Silk Layer

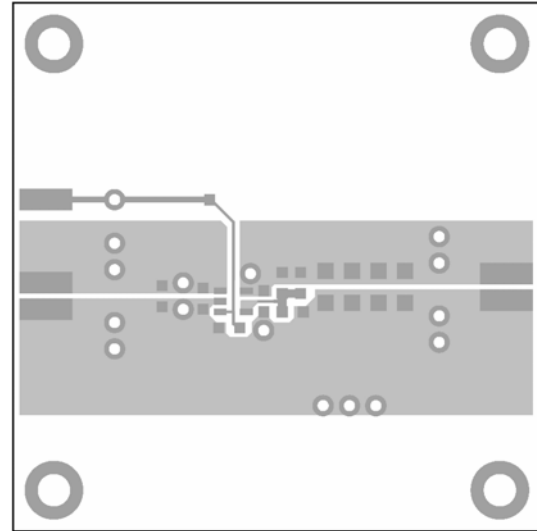

Figure 2—Top Layer

## QUICK START GUIDE

The output voltage of this board is set to 1.2V. The  $\overline{EN}$  pin is connected to ground with a 10kΩ resistor for automatic startup. You can connect  $\overline{EN}$  to VIN to disable the MP2000.

1. Attach the positive and negative ends of the load to the VOUT and GND pins, respectively.
2. Attach the input voltage ( $1.35V \leq V_{IN} \leq 6V$ ) and input ground to the VIN and GND pins, respectively.
3. The default resistor values on the board are R1=28.7kΩ and R2=20kΩ. Changing these resistor values will change the output voltage. Use the following equation to determine resistor values for different output voltages:

$$V_{OUT} = 0.5V \times \left( 1 + \frac{R1}{R2} \right)$$

T1 and T2 are test points for accurately measuring the input and output voltages.

**NOTICE:** The information in this document is subject to change without notice. Please contact MPS for current specifications. Users should warrant and guarantee that third party Intellectual Property rights are not infringed upon when integrating MPS products into any application. MPS will not assume any legal responsibility for any said applications.