

**High Speed Translator Buffer to CMOS (Selectable Drive)**

**FEATURES**

- CMOS output
- Selectable Drive capability (15pF or 30pF output load).
- Single AC coupled input (min. 100mV swing).
- Input range from DC to 200 MHz.
- 2.5V to 3.3V operation.
- Available in 8-Pin SOIC and 3x3mm QFN.

**DESCRIPTION**

The PLL130-07 is a low cost, high performance, high speed, buffer that reproduces any input frequency from DC to 200MHz. It provides CMOS output with 15pF output load drive capability. Any input signal with at least 100mV swing can be used as reference signal. This chip is ideal for conversion from sine wave to CMOS.

**PIN CONFIGURATION**

(TOP VIEW)

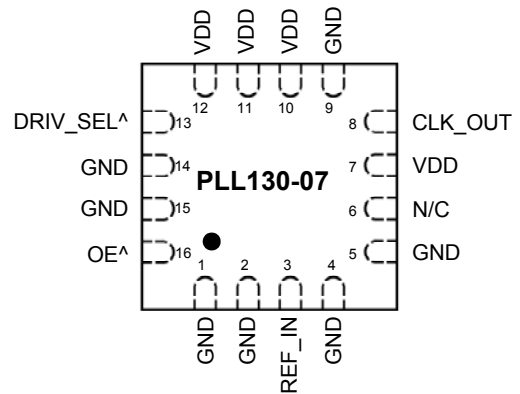
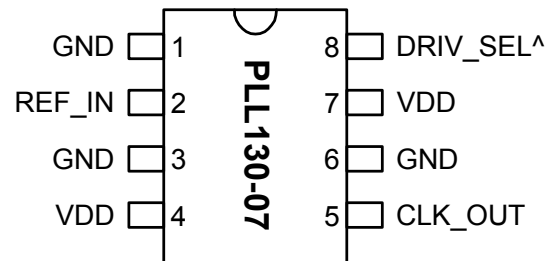

Note: ^ denotes internal pull up

**BLOCK DIAGRAM**

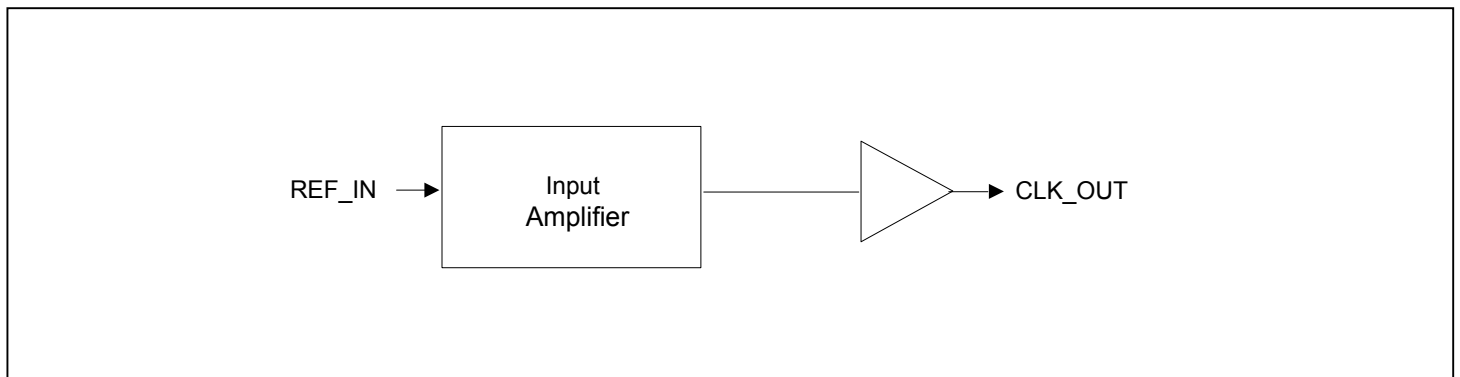

## High Speed Translator Buffer to CMOS (Selectable Drive)

### PIN DESCRIPTION

Name	8pin SOIC Pin number	3x3mm QFN Pin number	Type	Description
GND	1,3,6	1,2,4,5, 9,14,15	P	Ground.
VDD	4,7	7,10,11,12	P	Power supply.
DRIV_SEL	8	13	I	Drive Select input: '1' for standard drive, '0' for hi-drive output. Internal pull-up (default is '1').
REF_IN	2	3	I	Reference input signal. The frequency of this signal will be reproduced at the output (after translation to CMOS level).
CLK_OUT	5	8	O	CMOS clock output.
OE	N/A	16	I	Output enable ('1' for enable). Internal pull-up (default is '1').

### ELECTRICAL SPECIFICATIONS

#### 1. Absolute Maximum Ratings

PARAMETERS	SYMBOL	MIN.	MAX.	UNITS
Supply Voltage	$V_{DD}$		4.6	V
Input Voltage, dc	$V_I$	-0.5	$V_{DD}+0.5$	V
Output Voltage, dc	$V_O$	-0.5	$V_{DD}+0.5$	V
Storage Temperature	$T_S$	-65	150	°C
Ambient Operating Temperature*	$T_A$	-40	85	°C
Junction Temperature	$T_J$		125	°C
Lead Temperature (soldering, 10s)			260	°C
ESD Protection, Human Body Model			2	kV

Exposure of the device under conditions beyond the limits specified by Maximum Ratings for extended periods may cause permanent damage to the device and affect product reliability. These conditions represent a stress rating only, and functional operations of the device at these or any other conditions above the operational limits noted in this specification is not implied.

\* **Note:** Operating Temperature is guaranteed by design for all parts (COMMERCIAL and INDUSTRIAL), but tested for COMMERCIAL grade only.

#### 2. AC Specifications

PARAMETERS	CONDITIONS	MIN.	TYP.	MAX.	UNITS
Input Frequency		0		200	MHz
Input signal swing	REF_IN input	100			mV
Output Frequency		0		200	MHz

## High Speed Translator Buffer to CMOS (Selectable Drive)

### 3. CMOS Output Electrical Specifications

PARAMETERS	SYMBOL	CONDITIONS	MIN.	TYP.	MAX.	UNITS
Output High Voltage	$V_{OH}$	$I_{OH} = -12mA$	2.4			V
Output Low Voltage	$V_{OL}$	$I_{LO} = 12mA$			0.4	V
Output High Voltage at CMOS level	$V_{OHC}$	$I_{OH} = -4mA$	$V_{DD} - 0.4$			V
Output drive current		At TTL level (High drive*)	36	51		mA
		At TTL level (Standard drive)	12	17		mA

\* Note: High Drive CMOS is selectable through DRIV\_SEL selector input on pin 8(SOIC) or 13(QFN).

### 4. CMOS Switching Characteristics

PARAMETERS	SYMBOL	CONDITIONS	MIN.	TYP.	MAX.	UNITS
Output Clock Rise/Fall Time		0.8V ~ 2.0V with 10 pF load		1.15		ns
		0.3V ~ 3.0V with 15 pF load		3.7		
Output Clock Rise/Fall Time (High Drive*)		0.8V ~ 2.0V with 10 pF load		0.5		
		0.3V ~ 3.0V with 15 pF load		1.5		

\* Note: High Drive CMOS is selectable through DRIV\_SEL selector input on pin 8(SOIC) or 13(QFN).

**High Speed Translator Buffer to CMOS (Selectable Drive)**

**PACKAGE INFORMATION**

8 PIN ( dimensions in mm )

Narrow SOIC		
Symbol	Min.	Max.
A	1.47	1.73
A1	0.10	0.25
B	0.33	0.51
C	0.19	0.25
D	4.80	4.95
E	3.80	4.00
H	5.80	6.20
L	0.38	1.27
e	1.27 BSC	

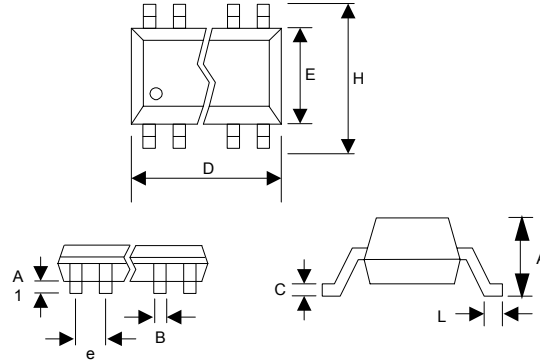

VARIATIONS:

SYMBOL	16 LD		
	MIN	NOM	MAX
e	0.50 BSC		
b	0.18	0.23	0.30
L	0.30	0.40	0.50
ND	4		
NE	4		

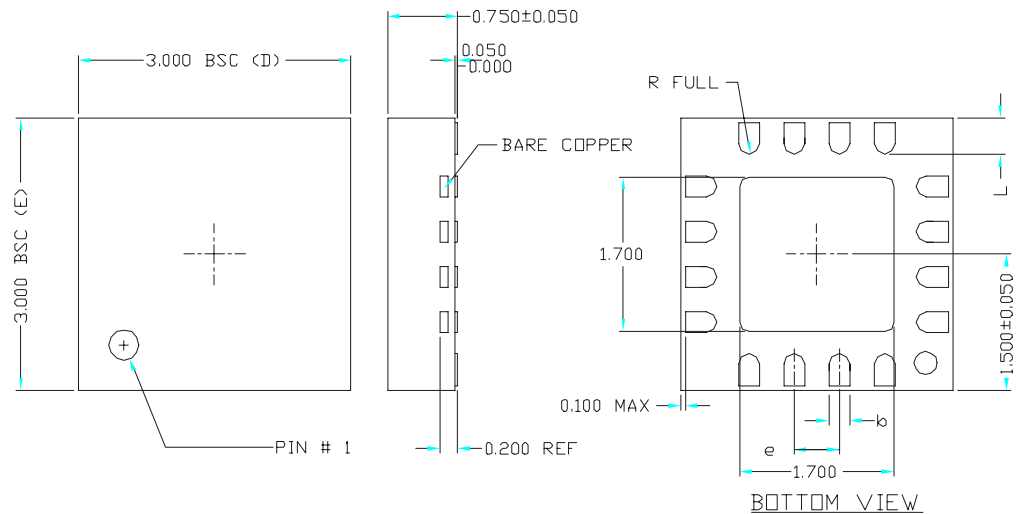

**High Speed Translator Buffer to CMOS (Selectable Drive)**

**ORDERING INFORMATION**

**For part ordering, please contact our Sales Department:**

47745 Fremont Blvd., Fremont, CA 94538, USA  
Tel: (510) 492-0990 Fax: (510) 492-0991

**PART NUMBER**

The order number for this device is a combination of the following:  
Device number, Package type and Operating temperature range

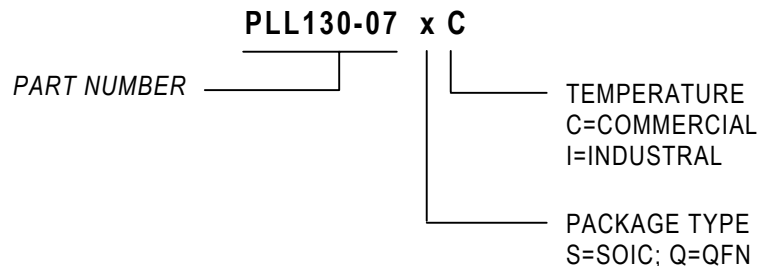

<u>Order Number</u>	<u>Marking</u>	<u>Package Option</u>
PLL130-07QC-R	P130-07QC	QFN - Tape and Reel
PLL130-07QC	P130-07QC	QFN - Tube
PLL130-07SC-R	P130-07SC	SOIC -Tape and Reel
PLL130-07SC	P130-07SC	SOIC - Tube

*PhaseLink Corporation, reserves the right to make changes in its products or specifications, or both at any time without notice. The information furnished by Phaselink is believed to be accurate and reliable. However, PhaseLink makes no guarantee or warranty concerning the accuracy of said information and shall not be responsible for any loss or damage of whatever nature resulting from the use of, or reliance upon this product.*

**LIFE SUPPORT POLICY:** PhaseLink's products are not authorized for use as critical components in life support devices or systems without the express written approval of the President of PhaseLink Corporation.