



STEVAL-ILL028V1

RGB LED driver for color displays and backlighting based on the STP1612PW05 and STM32

Data brief

Features

- Three STP1612PW05 (in QFN24 4 x 4 mm packages) connected to 16 RBG high-brightness LEDs
- One STM32 microcontroller using an internal HS oscillator
- One ST1S10 high-efficiency switching DC-DC power supply
- 7.5 - 18 V DC power supply with undifferentiated polarity and overvoltage protection
- DC input current: 0.7 A max, standard supply connector
- LED current regulation
- Test points for each main signal
- Microcontroller firmware update through JTAG interface
- Error LED and overtemperature LED for each driver
- 3 jumpers to disconnect the LEDs from the driver to test error detection mode
- 3 jumpers to enable LED shorting from the driver to test error detection mode
- Mini USB for board-to-PC connection
- Includes firmware to evaluate board features in standalone and non-standalone modes:
 - Adjustable color and brightness of each LED
 - Animated text
 - GUI software for LED diagnostics
- RoHS compliant



controlled through an STM32 microcontroller SPI interface and DMA (optional).

Description

The STEVAL-ILL028V1 demonstration board is an RGB LED driver for color displays and backlighting, designed as a platform for demonstrating the performance of the STP1612PW05 independent PWM LED driver,

1 Schematic diagram

Figure 1. Connectors, buttons, UART

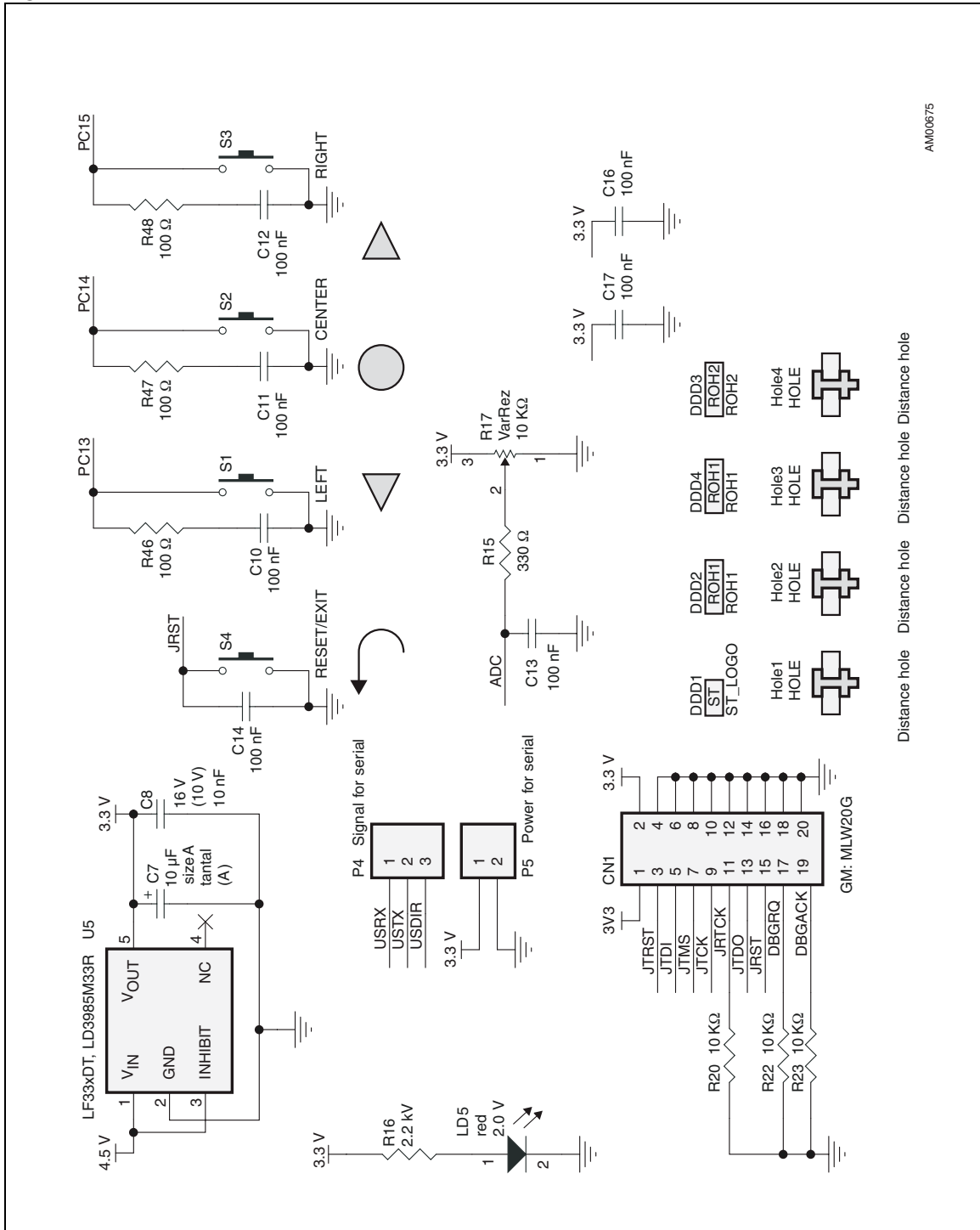
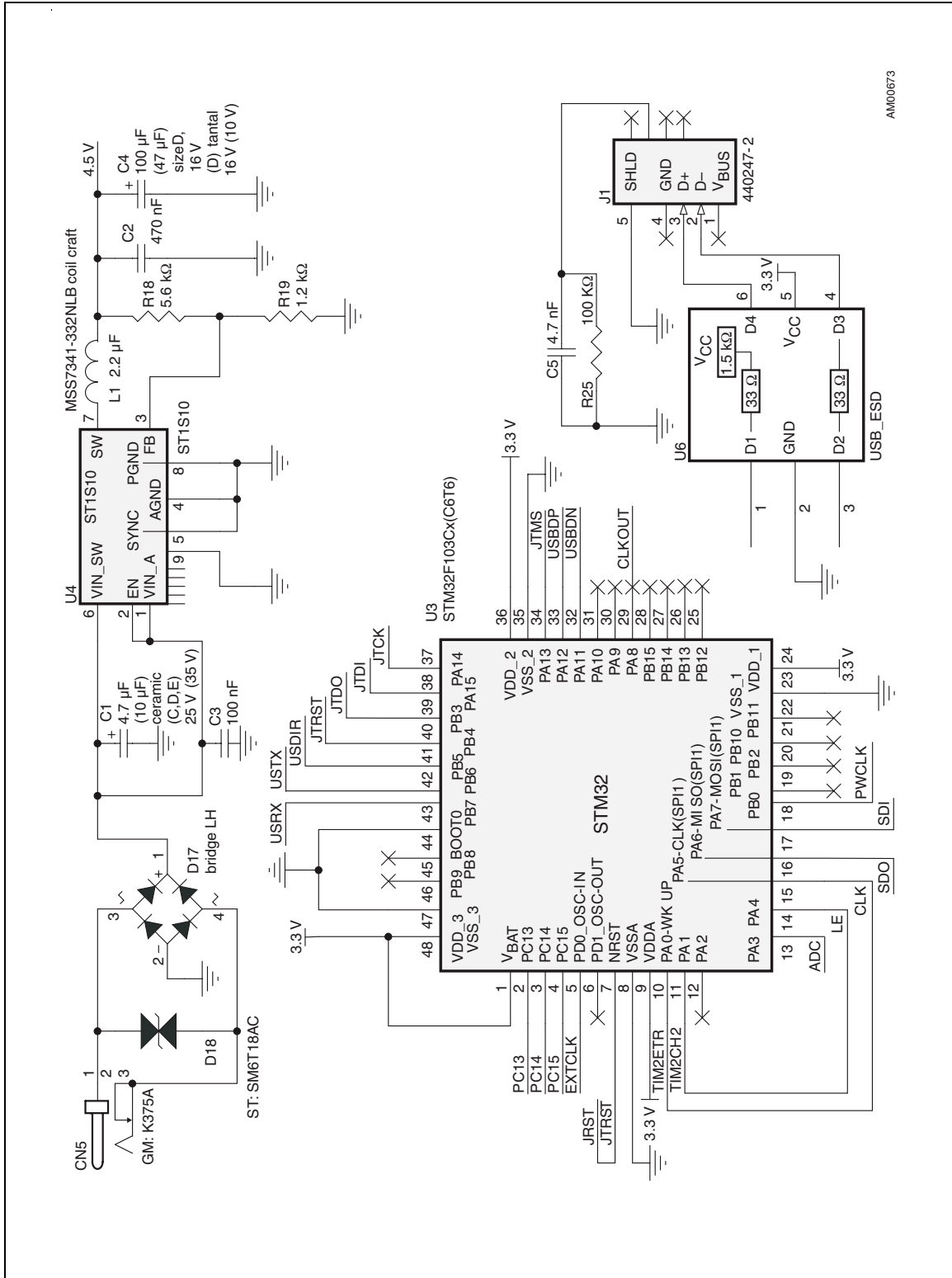

Figure 2. Microcontroller, USB, power supply



AM00673

Figure 3. High-brightness LEDs

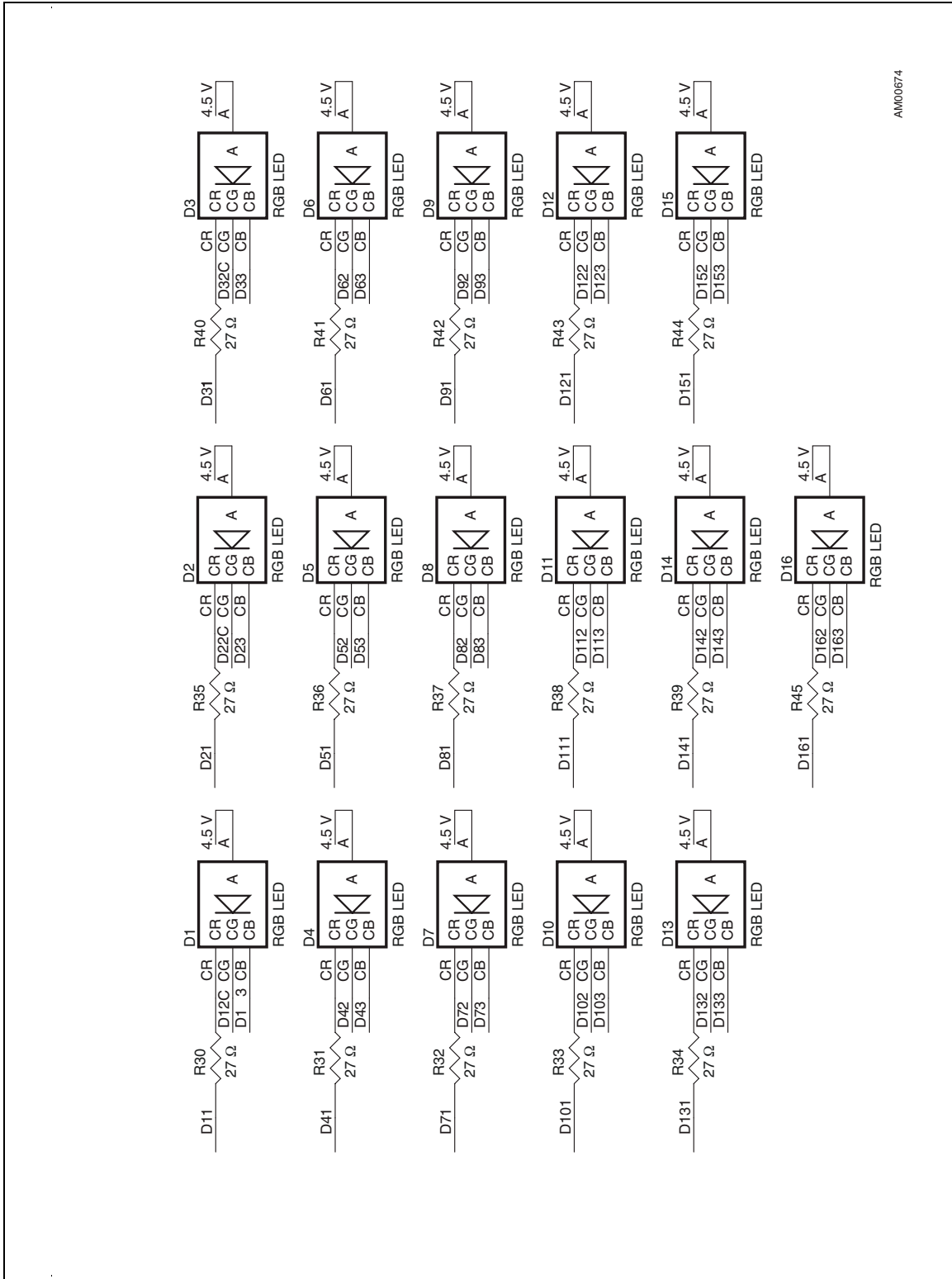
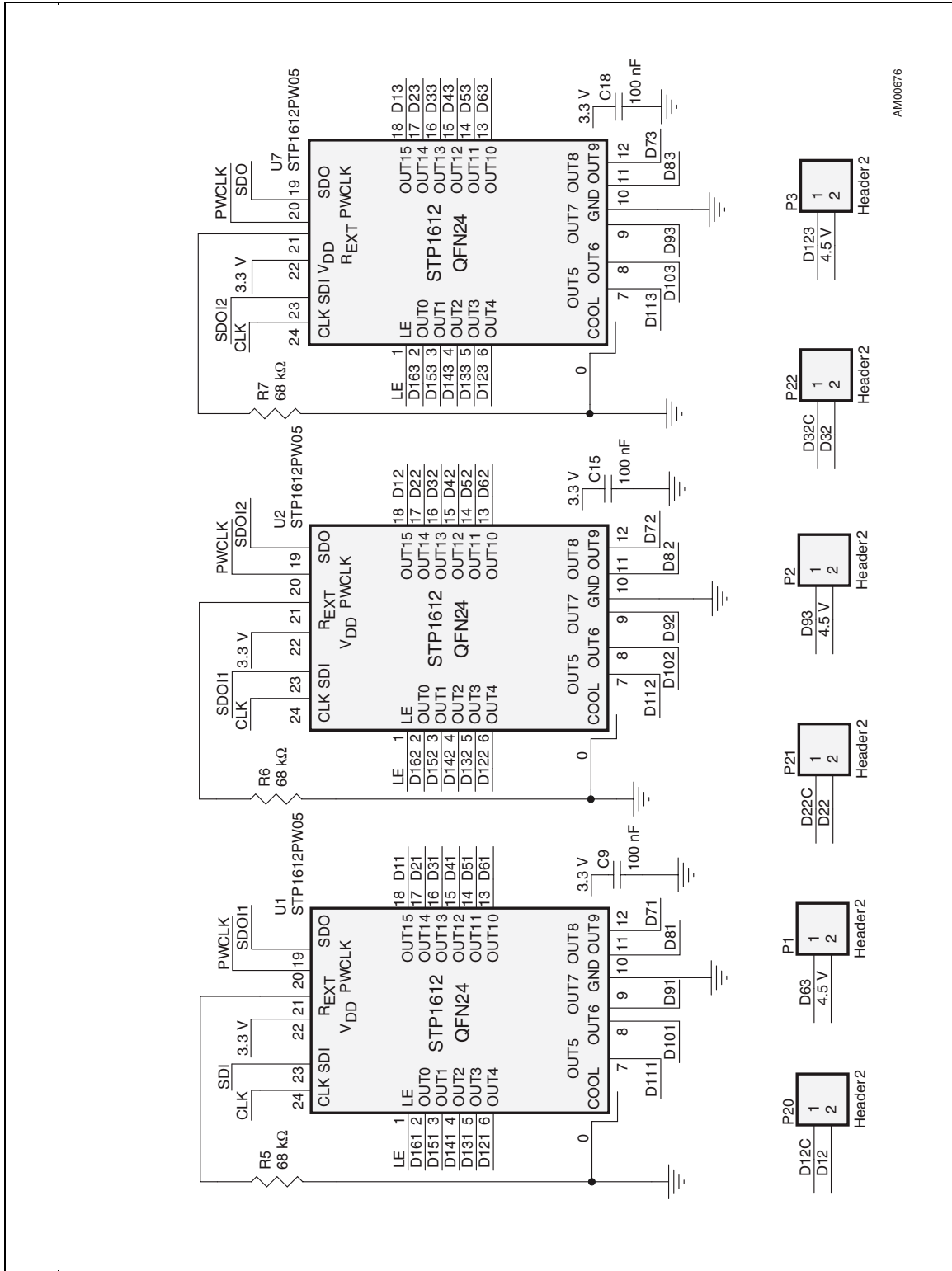

Figure 4. LED drivers



AM00676

2 Revision history

Table 1. Document revision history

Date	Revision	Changes
16-Jun-2010	1	Initial release.

Please Read Carefully:

Information in this document is provided solely in connection with ST products. STMicroelectronics NV and its subsidiaries ("ST") reserve the right to make changes, corrections, modifications or improvements, to this document, and the products and services described herein at any time, without notice.

All ST products are sold pursuant to ST's terms and conditions of sale.

Purchasers are solely responsible for the choice, selection and use of the ST products and services described herein, and ST assumes no liability whatsoever relating to the choice, selection or use of the ST products and services described herein.

No license, express or implied, by estoppel or otherwise, to any intellectual property rights is granted under this document. If any part of this document refers to any third party products or services it shall not be deemed a license grant by ST for the use of such third party products or services, or any intellectual property contained therein or considered as a warranty covering the use in any manner whatsoever of such third party products or services or any intellectual property contained therein.

UNLESS OTHERWISE SET FORTH IN ST'S TERMS AND CONDITIONS OF SALE ST DISCLAIMS ANY EXPRESS OR IMPLIED WARRANTY WITH RESPECT TO THE USE AND/OR SALE OF ST PRODUCTS INCLUDING WITHOUT LIMITATION IMPLIED WARRANTIES OF MERCHANTABILITY, FITNESS FOR A PARTICULAR PURPOSE (AND THEIR EQUIVALENTS UNDER THE LAWS OF ANY JURISDICTION), OR INFRINGEMENT OF ANY PATENT, COPYRIGHT OR OTHER INTELLECTUAL PROPERTY RIGHT.

UNLESS EXPRESSLY APPROVED IN WRITING BY AN AUTHORIZED ST REPRESENTATIVE, ST PRODUCTS ARE NOT RECOMMENDED, AUTHORIZED OR WARRANTED FOR USE IN MILITARY, AIR CRAFT, SPACE, LIFE SAVING, OR LIFE SUSTAINING APPLICATIONS, NOR IN PRODUCTS OR SYSTEMS WHERE FAILURE OR MALFUNCTION MAY RESULT IN PERSONAL INJURY, DEATH, OR SEVERE PROPERTY OR ENVIRONMENTAL DAMAGE. ST PRODUCTS WHICH ARE NOT SPECIFIED AS "AUTOMOTIVE GRADE" MAY ONLY BE USED IN AUTOMOTIVE APPLICATIONS AT USER'S OWN RISK.

Resale of ST products with provisions different from the statements and/or technical features set forth in this document shall immediately void any warranty granted by ST for the ST product or service described herein and shall not create or extend in any manner whatsoever, any liability of ST.

ST and the ST logo are trademarks or registered trademarks of ST in various countries.

Information in this document supersedes and replaces all information previously supplied.

The ST logo is a registered trademark of STMicroelectronics. All other names are the property of their respective owners.

© 2010 STMicroelectronics - All rights reserved

STMicroelectronics group of companies

Australia - Belgium - Brazil - Canada - China - Czech Republic - Finland - France - Germany - Hong Kong - India - Israel - Italy - Japan - Malaysia - Malta - Morocco - Philippines - Singapore - Spain - Sweden - Switzerland - United Kingdom - United States of America

www.st.com

