

Working voltage 5V**DESCRIPTION**

The STE0514 are designed by TVS device that is to protect sensitive electronics from damage or latch-up due to ESD. They are designed for use in applications where board space is at a premium.

STE0514 will protect up to four lines, and may be used on lines where the signal polarities swing above and below ground.

STE0514 offer desirable characteristics for board level protection including fast response time, low operating and clamping voltage without device degradation.

STE0514 may be used to meet the immunity requirements of IEC 61000-4-2, level 4. The small SOT-563 package makes them ideal for use in portable electronics such as cell phone, PDA's, notebook computers, digital cameras and MP3.

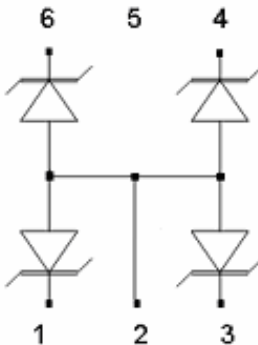
PIN CONFIGURATION**SOT-563 (SC-89)****FEATURE**

- Transient protection for data lines to IEC 61000-4-2 (ESD) +/- 15kV (air), +/-8KV (contact)
IEC 61000-4-4 (EFT) 40A (5/50ns)
- Protects four I/O lines
- Working voltage : 5V
- Low leakage current
- Low operating and clamping voltages

PART MARKING**STANSON TECHNOLOGY**

120 Bentley Square, Mountain View, Ca 94040 USA

TEL: (650) 9389294 FAX: (650) 9389295

Working voltage 5V**OREDRING INFORMATION**

Part Number	Package
STE0514D52RG	SOT-563

STE0514D52RG: Tape Reel; Pb-Free

ABSOLUTE MAXIMUM RATINGS (Ta = 25 Unless otherwise noted)

Parameter	Symbol	Typical	Unit
Peak Pulse Power (tp=8/20 us)	Ppk	250	W
Maximum Peak Pulse Current (tp=8/20us)	Ipp	7	A
ESD per ICE 61000-4-2 (Air)	Vpp	+/-15	KV
ESD per ICE 61000-4-2 (Contact)	Vpp	+/-8	KV
Operating Junction Temperature	Tj	-55~150	
Storage Temperature Range	TSTG	-55~150	
Lead Soldering Temperature	TL	260(10sec)	

ELECTRICAL CHARACTERISTICS (Ta = 25 Unless otherwise noted)

Parameter	Symbol	Conditions	Min	Typ	Max	Unit
Reverse Stand-Off Voltage	V _{RWM}				5	V
Reverse Breakdown Voltage	V _{BR}	I _t =1mA	6		8.5	V
Reverse Leakage Current	I _R	V _{RWM} =5V, T=25		0.01	1	uA
Reverse Leakage Current	I _R	V _{RWM} =3V, T=25		0.01	0.5	uA
Clamping Voltage	V _C	I _{pp} =1A, tp=8/20us			11.5	V
Clamping Voltage	V _C	I _{pp} =7A, tp=8/20us			15	V
Junction Capacitance	C _j	Between I/O Pin and GND V _R =0V, f =1MHz		20	30	pF

**STANSON TECHNOLOGY**

120 Bentley Square, Mountain View, Ca 94040 USA
 TEL: (650) 9389294 FAX: (650) 9389295

Working voltage 5V

TYPICAL CHARACTERISTICS

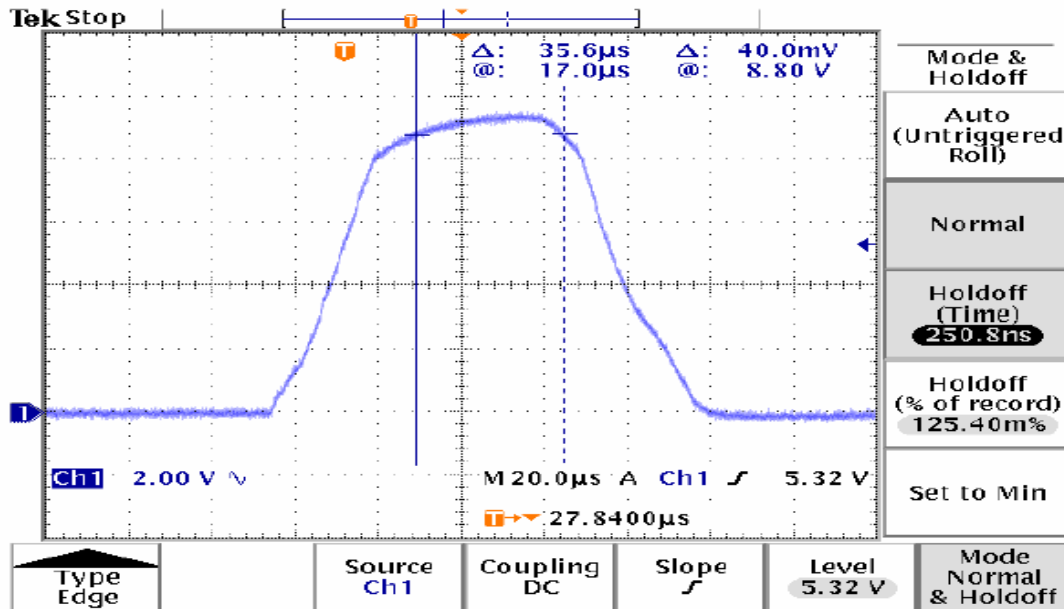

Clamping Voltage (Ipp = 1A , tp = 8/20 µs)

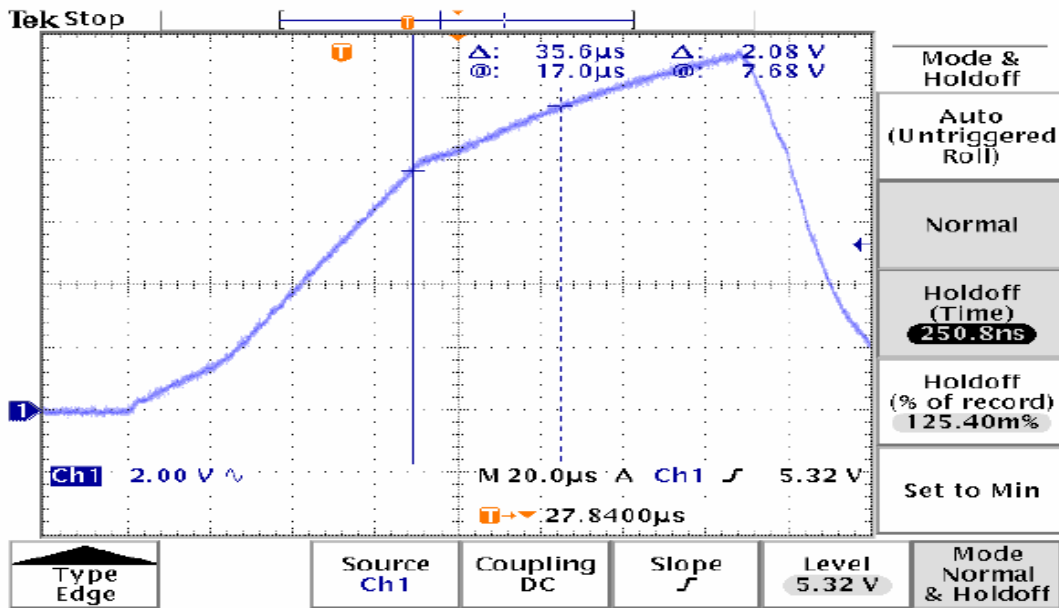

Clamping Voltage (Ipp = 7A , tp = 8/20 µs)



STANSON TECHNOLOGY

120 Bentley Square, Mountain View, Ca 94040 USA

TEL: (650) 9389294 FAX: (650) 9389295

Four-Line ESD Protection Array**STE0514****Working voltage 5V****APPLICATION NOTE****Device Connection for Protection of Four Data Lines**

STE0514 is designed to protect up to four data lines. The device is connected as follows :

1. The TVS protection of four I/O lines is achieved by connecting pins 1,3, 4, 6 to the data lines. Pin 2 is connected to ground. The ground connection should be made directly to the ground plane for best results. The path length is kept as short as possible to reduce the effects of parasitic inductance.

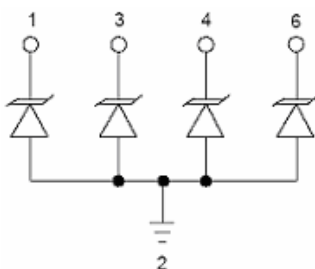
**Circuit Board Layout Recommendations for Suppression of ESD**

Good circuit board layout is critical for the suppression of ESD induced transients. The following guidelines are recommended:

1. Place the TVS near the input terminals or connectors to restrict transient coupling.
2. Minimize the path length between the TVS and the protected line.
3. Minimize all conductive loops including power and ground loops.
4. The ESD transient return path to ground should be kept as short as possible.
5. Never run critical signals near board edges
6. Use ground planes whenever possible.

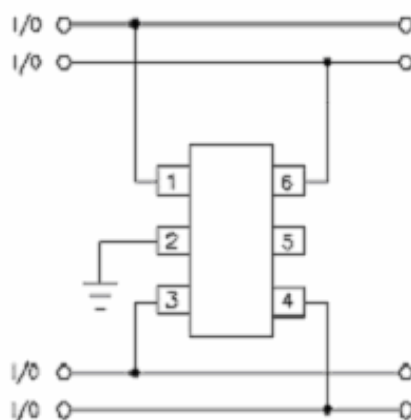
**STANSON TECHNOLOGY**

120 Bentley Square, Mountain View, Ca 94040 USA

TEL: (650) 9389294 FAX: (650) 9389295

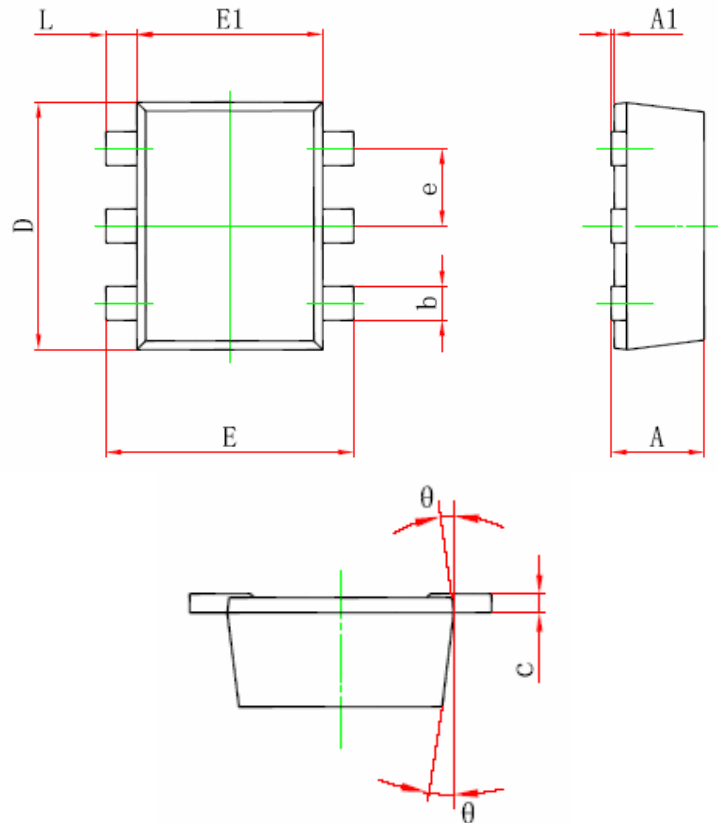
Four-Line ESD Protection Array**STE0514****Working voltage 5V****SOT-563 (SC-89) PACKAGE OUTLINE**

Symbol	Dimensions in Millimeters		Dimensions in Inches	
	Min.	Max.	Min.	Max.
A	0.525	0.600	0.021	0.024
A1	0.000	0.050	0.000	0.002
e	0.450	0.550	0.018	0.022
c	0.090	0.160	0.004	0.006
D	1.500	1.700	0.059	0.067
b	0.170	0.270	0.007	0.011
E1	1.100	1.300	0.043	0.051
E	1.500	1.700	0.059	0.067
L	0.100	0.300	0.004	0.012
θ	7° REF.		7° REF.	

**STANSON TECHNOLOGY**

120 Bentley Square, Mountain View, Ca 94040 USA

TEL: (650) 9389294 FAX: (650) 9389295

