

DC–20 GHz MMIC SPDT REFLECTIVE SWITCH
FEATURES

- Low insertion loss: 1.4 dB at 20 GHz
- High isolation: 37 dB at 20 GHz
- All reflective design
- Excellent low control voltage performance
- Available in die form

GENERAL DESCRIPTION

The FMS2024 is a low loss high isolation broadband single-pole-double-throw Gallium Arsenide switch, designed on the FL05 0.5 μ m switch process from Filtronic.

This process technology offers leading-edge performance optimised for switch applications. The FMS2024 is developed for the broadband communications, instrumentation and electronic warfare markets.

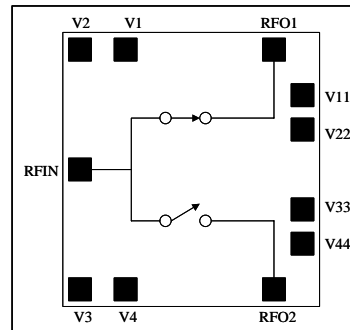
FUNCTIONAL SCHEMATIC

TYPICAL APPLICATIONS

- Broadband communications
- Test Instrumentation
- Fiber Optics
- Electronic warfare (ECM, ESM)

ELECTRICAL SPECIFICATIONS (small-signal unless otherwise stated)

PARAMETER	CONDITIONS	MIN	TYP	MAX	UNITS
Insertion Loss	DC	-1	-0.7	–	dB
	5 GHz	-1.25	-0.85	–	dB
	10 GHz	-1.6	-1.1	–	dB
	15 GHz	-1.6	-1.2	–	dB
	20 GHz	-1.8	-1.35	–	dB
Isolation	DC – 20 GHz	–	-37	-34	dB
Input Return Loss	DC – 20 GHz	–	-14	-11	dB
Output Return Loss	DC – 20 GHz	–	-15	-11	dB
P1dB	2 GHz	23	26	–	dBm
	10 GHz	22	24	–	
	20 GHz	22	24	–	
Switching speed	20% to 80% RF	–	20	–	ns
	80% to 20% RF	–	40	–	
	50% DC to 80% RF	–	30	–	
	50% DC to 20% RF	–	50	–	

Note 1: $T_{AMBIENT} = 25^{\circ}\text{C}$, $V_{ctrl} = 0\text{V}/-5\text{V}$, $Z_{IN} = Z_{OUT} = 50\Omega$.

Note 2: Sub-10ns 10% to 90% and 90% to 10% switching speeds can be achieved by changing the operating voltage V_{ctrl} from 0V / -5V to +1V / -5V.

ABSOLUTE MAXIMUM RATINGS

PARAMETER	SYMBOL	ABSOLUTE MAXIMUM
Max Input Power	Pin	+38dBm
Control Voltage	Vctrl	+1/-10V
Operating Temp	Toper	-40°C to +100°C
Storage Temp	Tstor	-55°C to +150°C

Note: Exceeding any one of these absolute maximum ratings may cause permanent damage to the device.

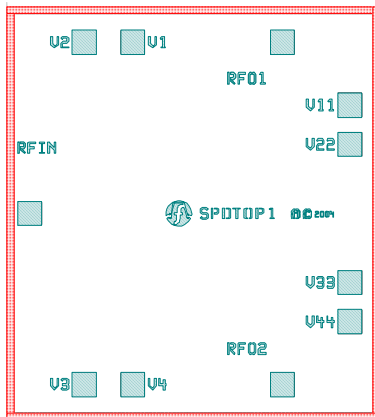
PAD LAYOUT

PAD NAME	DESCRIPTION	PIN COORDINATES (µm)
RFIN	RFIN	116,1055
RFO1	RFOUT1	1408,1929
RFO2	RFOUT2	1408,181
V1	V1	645, 1929
V2	V2	395, 1929
V3	V3	395, 181
V4	V4	645, 181
V11	V11	1753,1608
V22	V22	1753,1408
V33	V33	1753,702
V44	V44	1753,502

Note: Co-ordinates are referenced from the bottom left hand corner of the die to the centre of bond pad opening

DIE SIZE (µm)	DIE THICKNESS (µm)	MIN. BOND PAD PITCH (µm)	MIN. BOND PAD OPENING (µm x µm)
1910 x 2110	100	150	116 x 116

TRUTH TABLE

CONTROL LINES				RF PATH	
V1 OR V11	V2 OR V22	V3 OR V33	V4 OR V44	RFIN-RFO1	RFIN-RFO2
-5V	0V	-5V	0V	On	Off
0V	-5V	0V	-5V	Off	On
0V	-5V	-5V	0V	Off	Off

Note 1: -5V ± 0.2V; 0V ± 0.2V

Note 2: V11, V22, V33 and V44 are alternative control lines to V1, V2, V3 and V4 respectively

TYPICAL MEASURED PERFORMANCE ON WAFER:

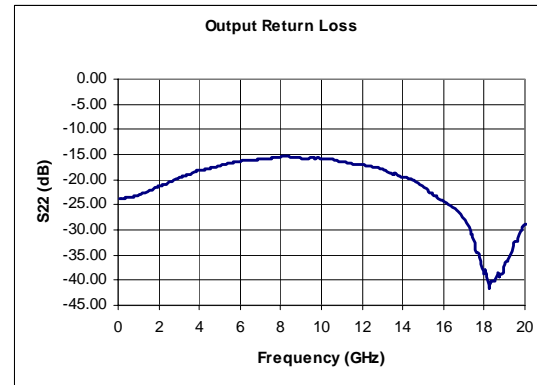
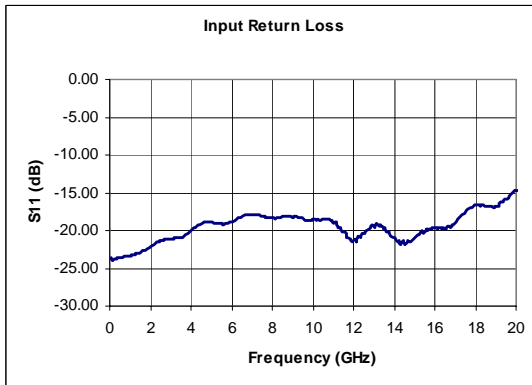
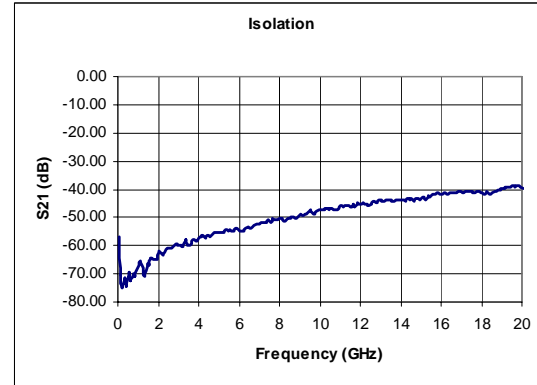
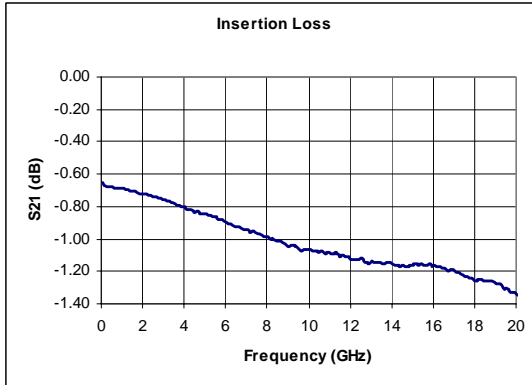
 Note: Measurement conditions $V_{CTRL} = -5V$ (low) & $0V$ (high), $T_{AMBIENT} = 25^{\circ}C$ unless otherwise stated

TYPICAL MEASURED PERFORMANCE ON WAFER OVER TEMPERATURE:

 Note: Measurement conditions $V_{CTRL} = -5V$ (low) & $0V$ (high)

— $T_{AMBIENT} = 25^{\circ}C$
 - - - $T_{COLD} = -40^{\circ}C$
 ⋯ $T_{HOT} = +85^{\circ}C$

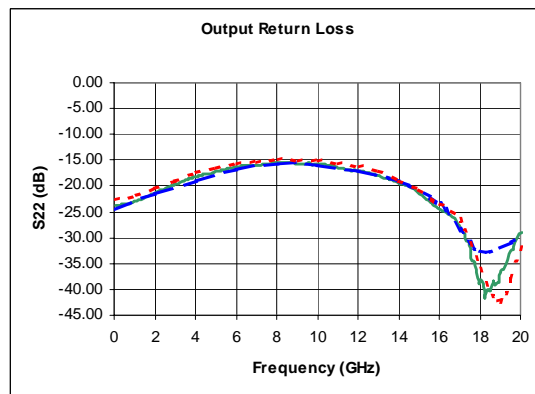
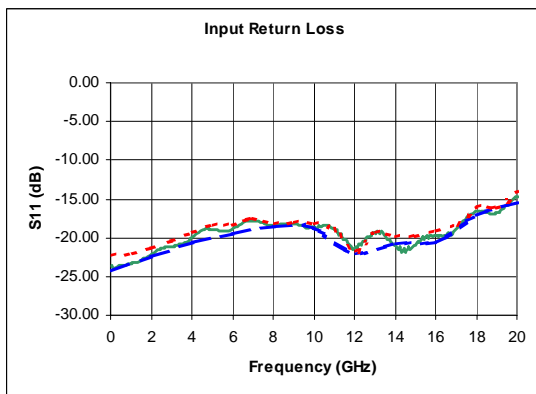
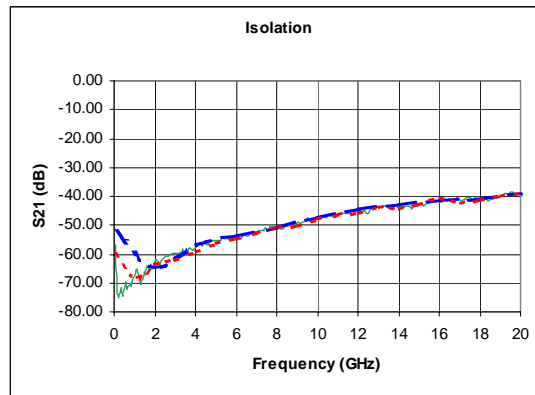
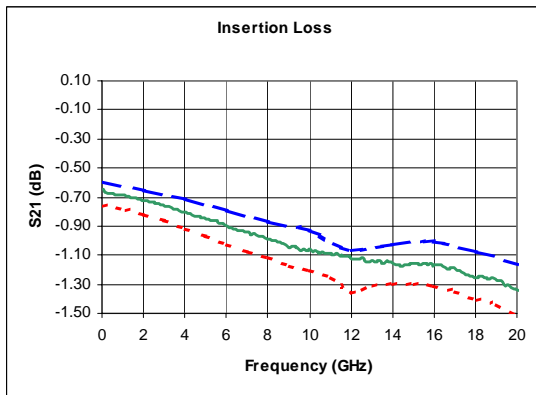

PREFERRED ASSEMBLY INSTRUCTIONS:

GaAs devices are fragile and should be handled with great care. Specially designed collets should be used where possible.

The back of the die is metallised and the recommended mounting method is by the use of solder or conductive epoxy. If epoxy is selected then it should be applied to the attachment surface uniformly and sparingly to avoid encroachment of epoxy on to the top face of the die and ideally should not exceed half the chip height. For automated dispense Ablestick LMISR4 is recommended and for manual dispense Ablestick 84-1 LMI or 84-1 LMIT are recommended. These should be cured at a temperature of 150°C for 1 hour in an oven especially set aside for epoxy curing only. If possible the curing oven should be flushed with dry nitrogen.

This part has gold (Au) bond pads requiring the use of gold (99.99% pure) bondwire. It is recommended that 25.4µm diameter gold wire be used. Thermosonic ball bonding is preferred. A nominal stage temperature of 150°C and a bonding force of 40g has been shown to give effective results for 25µm wire. Ultrasonic energy shall be kept to a minimum. For this bonding technique, stage temperature should not be raised above 200°C and bond force should not be raised above 60g. Thermosonic wedge bonding and thermocompression wedge bonding can also be used to achieve good wire bonds.

Bonds should be made from the die first and then to the mounting substrate or package. The physical length of the bondwires should be minimised especially when making RF or ground connections.

HANDLING PRECAUTIONS:



To avoid damage to the devices care should be exercised during handling. Proper Electrostatic Discharge (ESD) precautions should be observed at all stages of storage, handling, assembly, and testing. These devices should be treated as Class 1A (250-500 V) as defined in JEDEC Standard No. 22-A114. Further information on ESD control measures can be found in MIL-STD-1686 and MIL-HDBK-263.

APPLICATION NOTES & DESIGN DATA:

Application Notes and design data including S-parameters are available on request.

DISCLAIMERS:

This product is not designed for use in any space based or life sustaining/supporting equipment.

ORDERING INFORMATION:

PART NUMBER	DESCRIPTION
FMS2024-000	Die in Waffle-pack (Gel-pak available on request)