

## High Power Reflective GaAs SP4T Switch

### Features:

- ◆ 3x3x0.9mm Packaged pHEMT Switch
- ◆ NiPdAu finish for Military and High reliability applications
- ◆ Excellent low control voltage performance
- ◆ Excellent harmonic performance under GSM/DCS/PCS/EDGE power levels
- ◆ High isolation: >30dB at 0.9GHz
- ◆ Low Insertion loss: 0.5dB at 0.9GHz
- ◆ Low control current

### Functional Schematic

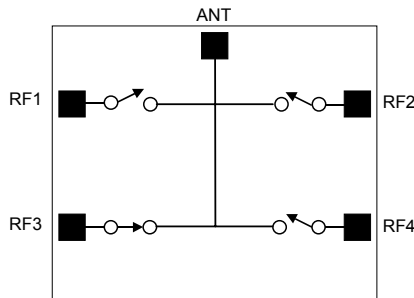

### Description and Applications:

The FMS2003QFN is a low loss, high power and linear single pole four throw Gallium Arsenide antenna switch designed for use in mobile handset applications. The die is fabricated using the Filtronic FLO5 0.5 $\mu$ m switch process technology, which offers excellent performance optimised for switch applications. The FMS2003QFN is designed for use in dual/tri and quad band GSM handset antenna switch modules and RF front-end modules. It can also find use in other applications where high power and linear RF switching is necessary.

### Electrical Specifications: (T<sub>AMBIENT</sub> = 25°C, V<sub>ctrl</sub> = 0V/2.5V, Z<sub>IN</sub> = Z<sub>OUT</sub> = 50 $\Omega$ )

Parameter	Test Conditions	Min	Typ	Max	Units
Insertion Loss	0.5 – 1.0 GHz		<0.62		dB
	1.0 – 2.0 GHz		<0.65		dB
Return Loss	0.5 – 2.5 GHz		20		dB
Isolation	0.5 – 1.0 GHz		>30		dB
	1.0 – 2.0 GHz		>26		dB
2nd Harmonic Level	1 GHz, P <sub>in</sub> = +35 dBm, 100% Duty Cycle		-69		dBc
	2 GHz, P <sub>in</sub> = +33dBm, 100% Duty Cycle		-67		dBc
3rd Harmonic Level	1 GHz, P <sub>in</sub> = +35 dBm, 100% Duty Cycle		-69		dBc
	2 GHz, P <sub>in</sub> = +33dBm, 100% Duty Cycle		-70		dBc
Switching speed : Trise, Tfall	10% to 90% RF		<0.15		$\mu$ s
	90% to 10% RF		<0.06		$\mu$ s
P0.1dB	0.5 – 1.0 GHz		38		dBm
	1.0 – 2.0 GHz		38		dBm
IP3	0.5 – 1.0 GHz		>65		dBm
	1.0 – 2.0 GHz		>62		dBm
Cross modulation	Tx1 836Hz Tx2 837MHz +21dBm Rx1 880MHz -25dBm Tx1 1879.5MHz Tx2 1880.5MHz +21dBm,Rx1 1960MHz -25dBm		>110		dBm
Control Current	+35dBm RF input @1GHz		<10		$\mu$ A

**Absolute Maximum Ratings:**

Parameter	Symbol	Absolute Maximum
Max Input Power	Pin	+38dBm
Control Voltage	V ctrl	+5V
Operating Temp	T oper	-40°C to +100°C
Storage Temp	T stor	-55°C to +150°C

**Note:** Exceeding any one of these absolute maximum ratings may cause permanent damage to the device.

**Truth Table:**

Switch State	V1	V2	V3	V4	ANT TO RF1	ANT TO RF2	ANT TO RF1	ANT TO RF2
(A)	HIGH	LOW	LOW	LOW	Insertion Loss	Isolation	Isolation	Isolation
(B)	LOW	HIGH	LOW	LOW	Isolation	Insertion Loss	Isolation	Isolation
(C)	LOW	LOW	HIGH	LOW	Isolation	Isolation	Insertion Loss	Isolation
(D)	LOW	LOW	LOW	HIGH	Isolation	Isolation	Isolation	Insertion Loss

**General Test Conditions:**

Bias Voltages	LOW = 0V to 0.2V HIGH +2.5V to +5V
Port Impedances	50Ω
Off arm termination	50Ω

**Note:** External DC blocking capacitors are required on all RF ports (typ: 100pF)

**Typical Measured Performance on Evaluation Board (De-Embedded):**

(Measurement Conditions  $V_{CTRL} = 2.5V$  (high) &  $0V$  (low),  $T_{AMBIENT} = 25^{\circ}C$  unless otherwise stated)

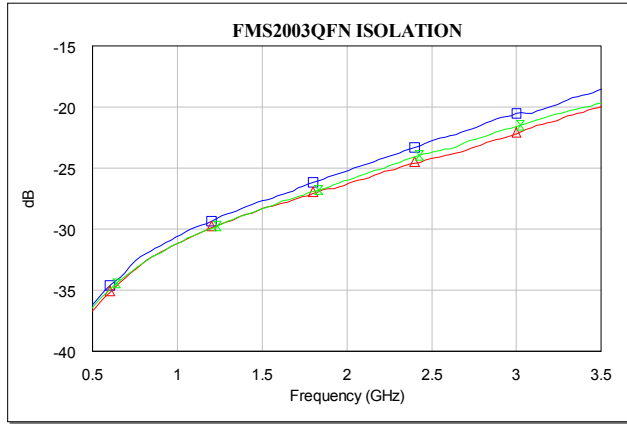
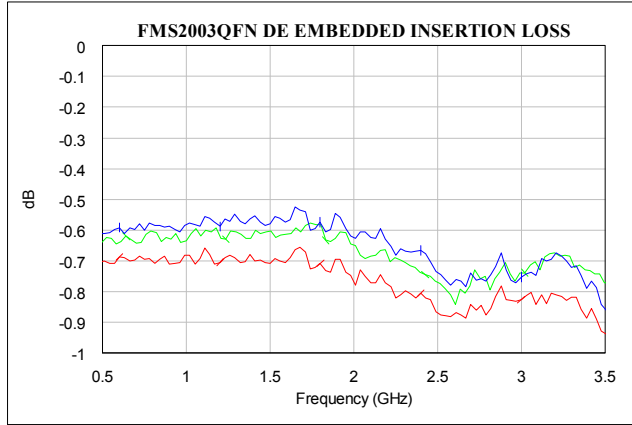

Key To Measurements	
	Measurement at -40°C
	Measurement at 85°C
	Measurement at 25°C

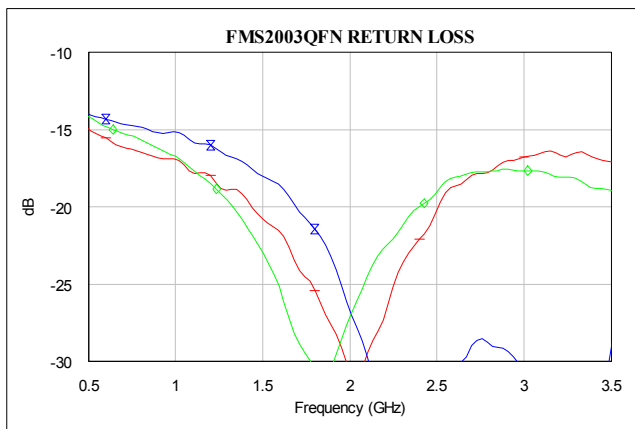

**Pad Layout:**

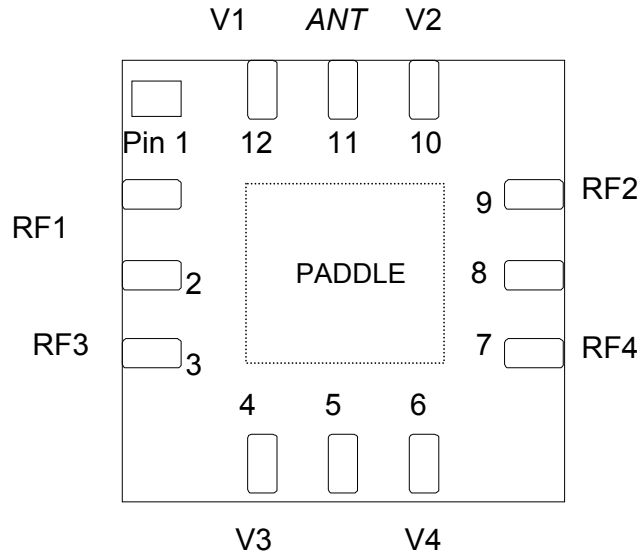

\*View from the top of the package

Pin Number	Description
1	RF1
2	GND
3	RF3
4	V3
5	N/C
6	V4
7	RF4
8	GND
9	RF2
10	V2
11	ANT RF
12	V1
PADDLE	GND

**QFN 12 Lead 3\*3 Package Outline:**

- ◆ NiPdAu finish for Military and High reliability applications

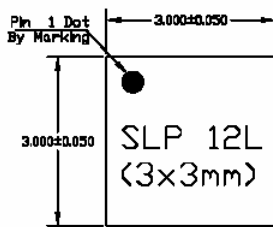

Top View

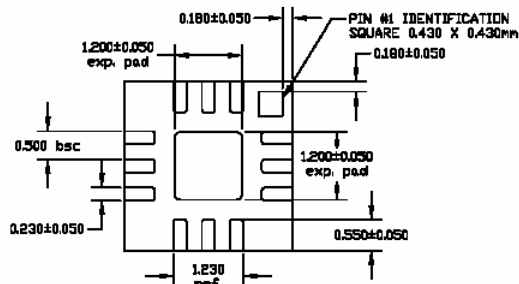

Btm View

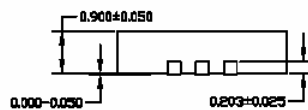

Side View

Preliminary specifications subject to change without notice

**Filtronic Compound Semiconductors Ltd**

Contact Details (UK): Tel: +44 (0) 1325 301111 Fax: +44 (0) 1325 306177 Email: sales@filcs.com

Contact Details (USA): Tel: +1 (408) 850-5790 Fax: +1 (408) 850-5766 Email: sales@filcsi.com

Website: www.filtronic.com

**Evaluation Board:**

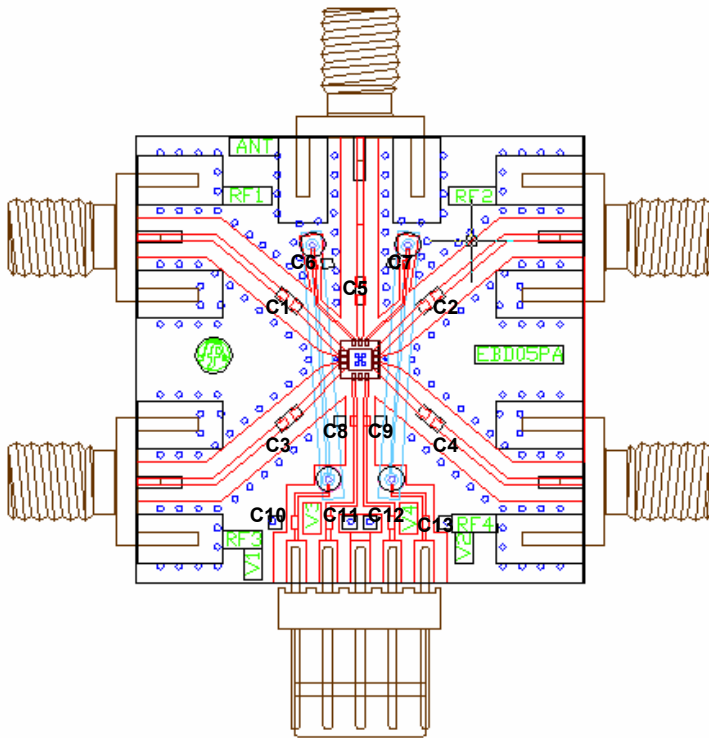

BOM	
Label	Component
C10, C11, C12, C13	Capacitor, 470pF, 0603
C1, C2, C3, C4, C5	Capacitor, 100pF, 0402
C6, C7, C8, C9	Capacitor, 47pF, 0402
BOARD	Preferred evaluation board material is 0.25 mm thick ROGERS RT4350. All RF tracks should be 50 ohm characteristic impedance.

**Evaluation Board De-Embedding Data (Measured):**

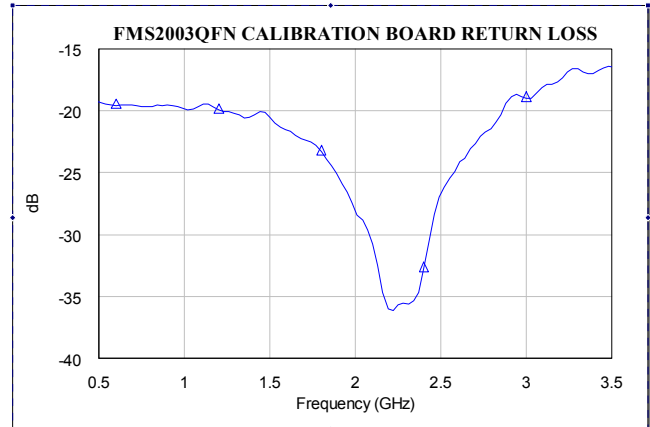
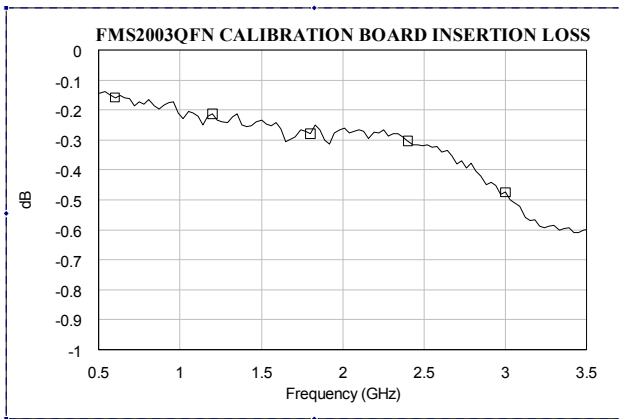

Preliminary specifications subject to change without notice

**Filtron Compound Semiconductors Ltd**

Contact Details (UK): Tel: +44 (0) 1325 301111 Fax: +44 (0) 1325 306177 Email: sales@filcs.com

Contact Details (USA): Tel: +1 (408) 988 1845 Fax: +1 (408) 970 9950 Email: sales@filcsi.com

Website: www.filtron.com

**Ordering Information:**

Part Number	Description
FMS2003-005	Packaged Die
FMS2003-005-EB	Packaged die mounted on evaluation board

**Handling Precautions:**

To avoid damage to the devices care should be exercised during handling. Proper Electrostatic Discharge (ESD) precautions should be observed at all stages of storage, handling, assembly, and testing. These devices should be treated as Class 1A as defined in Jedec Standard No.22-A114 (0-500V).

Further information on ESD control measures can be found in MIL-STD-1686 and MIL-HDBK-263.

**Preferred Assembly Instructions:**

Please refer to FCSL applications note: FAN 003 (handling and assembly of Filtronic QFN devices)

**Disclaimers:**

This product is not designed for use in any space based or life sustaining/supporting equipment.