

MITSUBISHI IGBT MODULES
CM900DU-24NF

HIGH POWER SWITCHING USE

CM900DU-24NF



- Ic 900A
- VCES 1200V
- Insulated Type
- 2-elements in a pack

APPLICATION

UPS & General purpose inverters, etc

OUTLINE DRAWING & CIRCUIT DIAGRAM

Dimensions in mm

A,B HOUSING Type
 (J. S. T. Mfg. Co. Ltd)
 A : VHR-2N
 B : VHR-5N

Tc measured point
 (The side of Cu
 base plate)

Tc measured point
 (The side of Cu
 base plate)

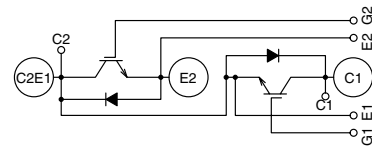
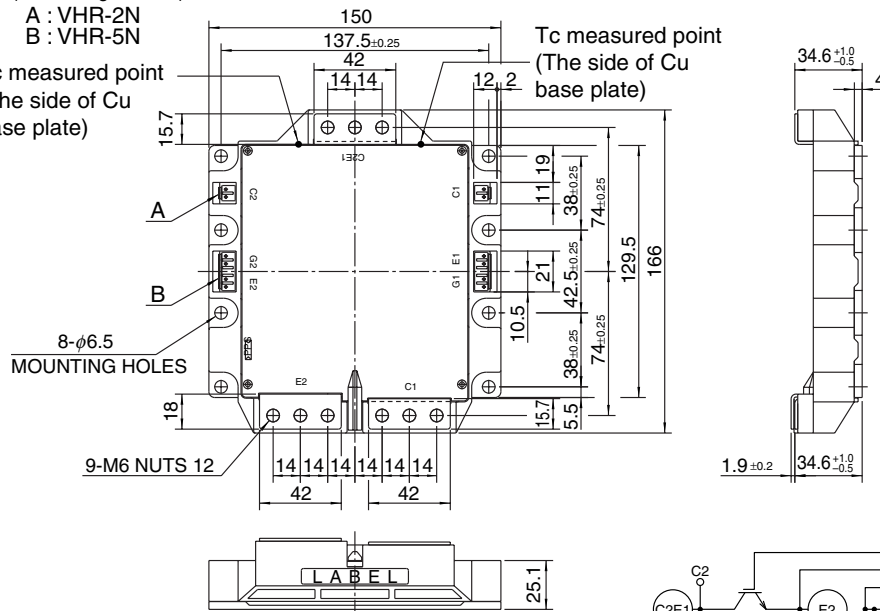

CIRCUIT DIAGRAM

MAXIMUM RATINGS (T_j = 25°C, unless otherwise specified)

Symbol	Parameter	Conditions	Ratings	Unit
V _{CES}	Collector-emitter voltage	G-E Short	1200	V
V _{GES}	Gate-emitter voltage	C-E Short	±20	V
I _C	Collector current	T _C ' = 96°C ^{*1}	900	A
I _{CM}		Pulse (Note 2)	1800	
I _E (Note 1)	Emitter current	T _C = 25°C	900	A
I _{EM} (Note 1)		Pulse (Note 2)	1800	
P _C (Note 3)	Maximum collector dissipation	T _C = 25°C	2550	W
T _j	Junction temperature		-40 ~ +150	°C
T _{stg}	Storage temperature ^{*4}		-40 ~ +125	°C
V _{iso}	Isolation voltage	Terminals to base plate, f = 60Hz, AC 1 minute	2500	V _{rms}
—	Torque strength	Main terminals M6 screw	3.5 ~ 4.5	N • m
		Mounting M6 screw	3.5 ~ 4.5	N • m
—	Weight	Typical value	1400	g

ELECTRICAL CHARACTERISTICS (T_j = 25°C, unless otherwise specified)

Symbol	Parameter	Test conditions	Limits			Unit
			Min.	Typ.	Max.	
I _{CES}	Collector cutoff current	V _{CE} = V _{CES} , V _{GE} = 0V	—	—	1	mA
V _{GE(th)}	Gate-emitter threshold voltage	I _C = 90mA, V _{CE} = 10V	6	7	8	V
I _{GES}	Gate leakage current	±V _{GE} = V _{GES} , V _{CE} = 0V	—	—	1	μA
V _{CE(sat)} (chip)	Collector-emitter saturation voltage (without lead resistance)	I _C = 900A, V _{GE} = 15V (Note 4) T _j = 25°C T _j = 125°C	—	1.8	2.5	V
R _(lead)	Module lead resistance	I _C = 900A, terminal-chip	—	0.286	—	
C _{ies}	Input capacitance	V _{CE} = 10V V _{GE} = 0V	—	—	140	nF
C _{oes}	Output capacitance		—	—	16	
C _{res}	Reverse transfer capacitance		—	—	3	
Q _G	Total gate charge	V _{CC} = 600V, I _C = 900A, V _{GE} = 15V	—	4800	—	nC
t _{d(on)}	Turn-on delay time	V _{CC} = 600V, I _C = 900A V _{GE} = ±15V R _G = 0.35Ω, Inductive load	—	—	600	ns
t _r	Turn-on rise time		—	—	200	
t _{d(off)}	Turn-off delay time		—	—	800	
t _f	Turn-off fall time		—	—	300	
t _{rr} (Note 1)	Reverse recovery time		I _E = 900A	—	—	
Q _{rr} (Note 1)	Reverse recovery charge		—	50	—	μC
V _{EC} (Note 1) (chip)	Emitter-collector voltage (without lead resistance)	I _E = 900A, V _{GE} = 0V	—	—	3.2	V
R _{th(j-c)Q}	Thermal resistance ^{*3}	IGBT part (1/2 module)	—	—	0.049	K/W
R _{th(j-c)R}		FWDi part (1/2 module)	—	—	0.078	
R _{th(c-f)}	Contact thermal resistance ^{*2}	Case to heat sink, Thermal compound applied (1/2 module)	—	0.016	—	
R _{th(j-c)Q}	Thermal resistance ^{*1}	Case temperature measured point is just under the chips (IGBT part)	—	—	0.021	
R _{th(j-c)R}		Case temperature measured point is just under the chips (FWDi part)	—	—	0.034	
R _G	External gate resistance		0.35	—	2.2	Ω

Note 1. I_E, V_{EC}, t_{rr} & Q_{rr} represent characteristics of the anti-parallel, emitter-collector free-wheel diode (FWDi).

2. Pulse width and repetition rate should be such that the device junction temperature (T_j) does not exceed T_{jmax} rating.

3. Junction temperature (T_j) should not increase beyond 150°C.

4. Pulse width and repetition rate should be such as to cause negligible temperature rise.

*1 : Case temperature (T_c) measured point is just under the chips.

If you use this value, R_{th(t-a)} should be measured just under the chips.

*2 : Typical value is measured by using thermally conductive grease of λ = 0.9[W/(m • K)].

*3 : Case temperature (T_c) measured point is shown in page OUTLINE DRAWING.

*4 : The operation temperature is restrained by the permission temperature of female connector.

PERFORMANCE CURVES

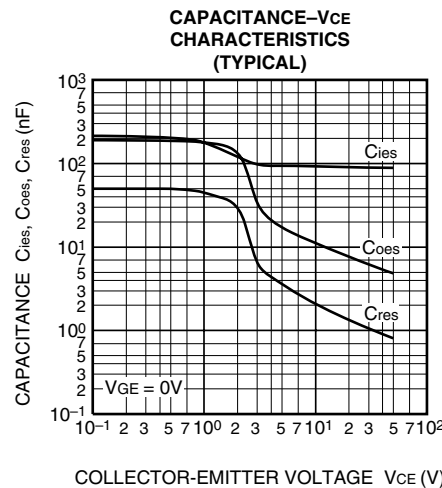
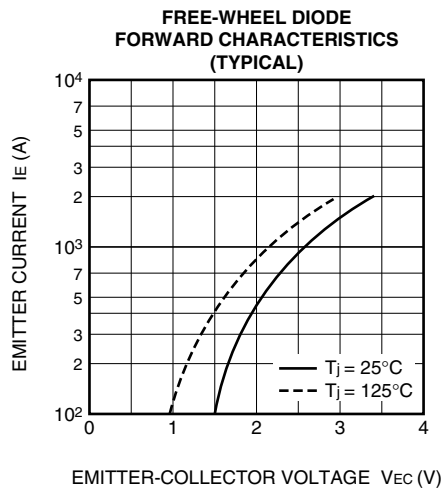
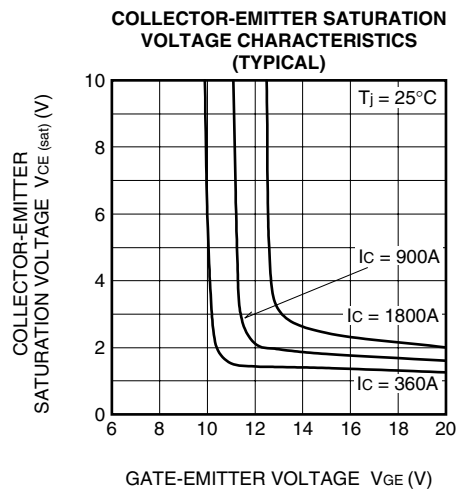
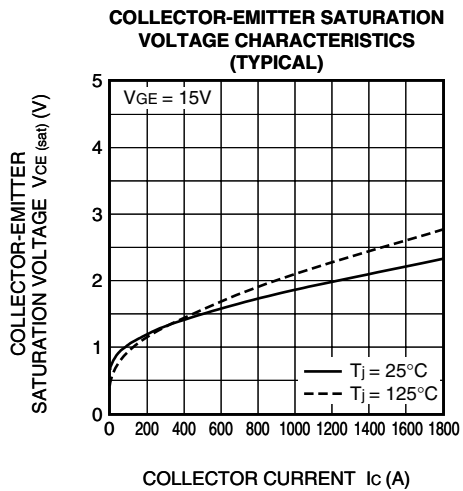
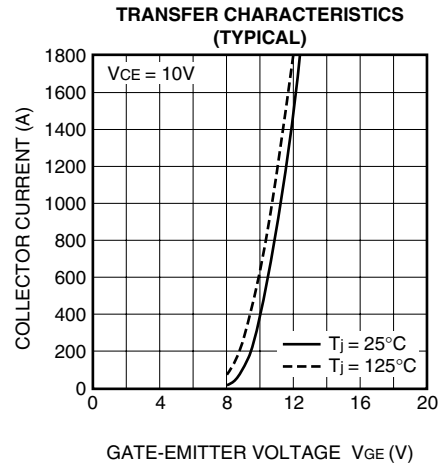
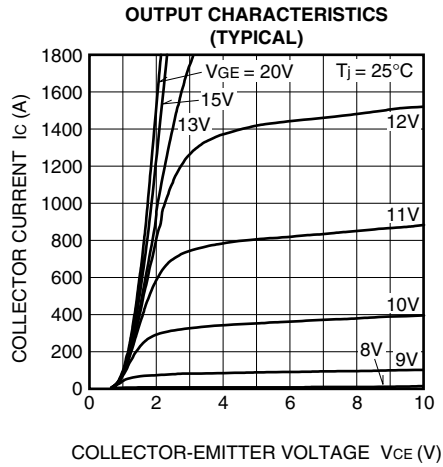

CM900DU-24NF

HIGH POWER SWITCHING USE

HALF-BRIDGE SWITCHING CHARACTERISTICS (TYPICAL)

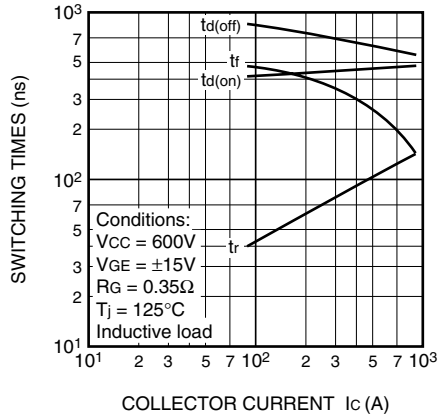

REVERSE RECOVERY CHARACTERISTICS OF FREE-WHEEL DIODE (TYPICAL)

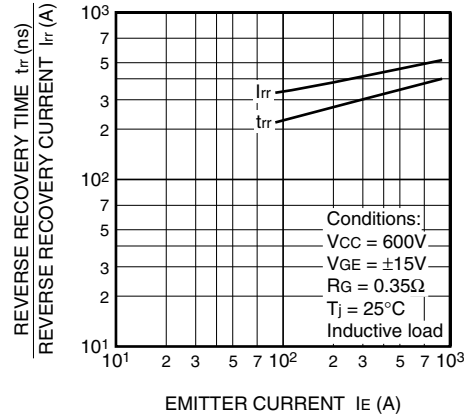

TRANSIENT THERMAL IMPEDANCE CHARACTERISTICS (IGBT part & FWDi part)

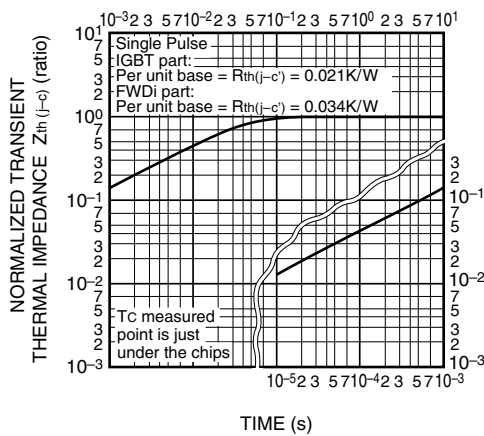

GATE CHARGE CHARACTERISTICS (TYPICAL)

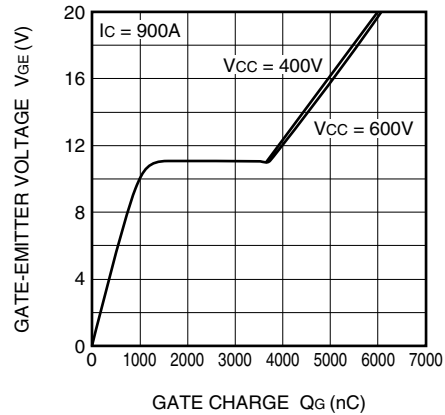

Ic-Esw (TYPICAL)

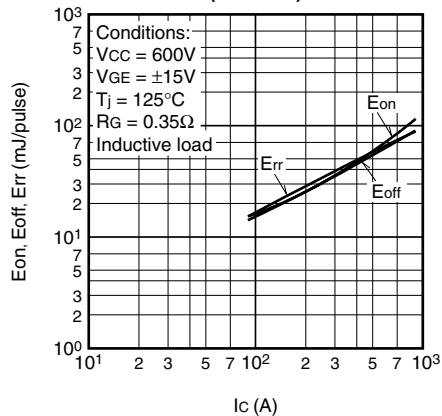

Rg-Esw (TYPICAL)

